

Mobile Anaerobe Laboratory

ROBERT S. FULGHUM

Department of Oral Biology, College of Dentistry, University of Kentucky, Lexington, Kentucky 40506

Received for publication 28 September 1970

A laboratory cart equipped for obtaining clinical samples at bedside or operator and for inoculating prereduced media for cultivation of medically important anaerobes is described.

Species of obligately anaerobic bacteria are not often isolated by the routine clinical laboratory methods. These anaerobic bacteria occur in 68% of specimens examined, excluding feces, urine, and throat specimens. Of all such specimens examined, approximately 25% contain only obligately anaerobic bacteria, 50% contain both obligately anaerobic and facultatively anaerobic bacteria, and 25% contain only facultatively anaerobic bacteria (W. E. C. Moore, *personal communication*). Improved culturing techniques for examination of clinical specimens likely to contain obligately anaerobic bacteria have been developed by the Virginia Polytechnic Institute and State University (VPISU) Anaerobe Laboratory (1, 3). Holding and transporting specimens containing anaerobes in transport media, saline, or culture media may often lead to loss of viability of obligate anaerobes and to the overgrowth of facultatively anaerobic organisms from mixed culture infections. The holding-transport procedure now recommended by the VPISU Anaerobe Laboratory is to place all specimens into sterile, dry, oxygen-free, CO₂-filled, stoppered tubes and to hold at room temperature (W. E. C. Moore, *personal communication*). Alternatively, specimens should be cultured immediately.

The present communication describes a mobile unit which may be moved into the hospital room, operator, or wherever necessary to obtain clinical specimens for laboratory study utilizing the prereduced media and techniques recommended by the VPISU Anaerobe Laboratory (1, 3). Figure 1 depicts a laboratory cart outfitted for these techniques. An intermediate size (Airco size 30) cylinder containing 3% hydrogen in carbon dioxide (see A in Fig. 1) with a metal diaphragm single-stage reducing valve (B) supplies the gas phase. This gas is led from the cylinder on the lower shelf via 0.25 inch (ca. 0.63 cm) copper tubing (C) to a Deoxo catalyst (D) which removes trace amounts of oxygen from the gas mixture. The gas is then dispensed to sample tubes or to

roll tubes of prereduced isolation agar medium by means of 16-gauge cannulae (E) attached to the outlet of the Deoxo catalyst by means of neoprene or butyl rubber tubing. The mobile anaerobe laboratory unit may also be equipped with other devices for assisting in the aseptic anaerobic transfer and inoculation of prereduced media with specimens thought to contain anaerobic bac-

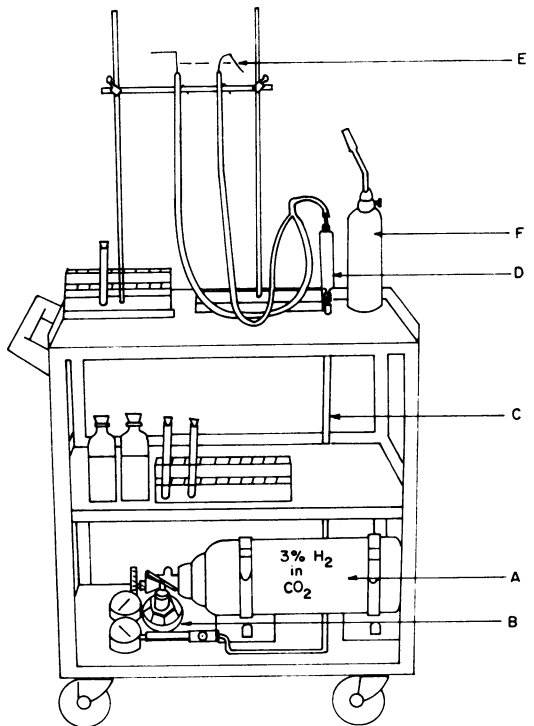

FIG. 1. Sketch of mobile anaerobe laboratory cart. (A) Cylinder of mixed gas, (B) diffusion-resistant reducing valve regulator, (C) copper tubing gas line, (D) Deoxo catalyst gas purifier, (E) oxygen-free CO₂ gas-phase dispensing cannulae, and (F) propane burner for flaming needles, tubes, etc.

teria. For example, we have found a roll tube streaker to be a most helpful addition for streaking tubes of prereduced media directly with the clinical specimen material. For the smaller laboratory, such a mobile anaerobe laboratory unit could also serve as the anaerobe apparatus for most of the anaerobic culturing.

In our hands, the mobile anaerobe unit is being used to inoculate prereduced media with specimens taken directly from periodontal lesions, necrotic dental pulps, periapical abscesses, and other oral lesions. The unit is also used in the University Hospital to obtain specimens and to inoculate specimens directly from patients to prereduced media. The direct inoculation of specimens into prereduced media saves time and equipment. It protects oxygen-susceptible organisms from the effects of oxygen and oxidized medium components (2). The use of this self-contained anaerobe unit does not inconvenience the

attending physician or dentist. Successful recovery of strict anaerobic bacteria from mixed culture infections has resulted from the use of this unit.

The financial support for this work was obtained from Public Health Service Grant FR-05314, General Research Support Branch, for which we are grateful.

We are indebted to W. E. C. Moore for suggestions that led to the development of this apparatus.

LITERATURE CITED

1. Blair, J. E., E. H. Lennette, and J. P. Truant, (ed.). 1970. Manual of clinical microbiology. American Society for Microbiology, Bethesda, Md.
2. Smith, L. D. S. and L. V. Holdeman. 1968. The pathogenic anaerobic bacteria, part I. Charles C Thomas, Publisher, Springfield, Ill.
3. Virginia Polytechnic Institute and State University Anaerobe Laboratory. 1970. Outline of clinical methods in anaerobic bacteriology, 2nd Rev. Virginia Polytechnic Institute and State University Anaerobe Laboratory, Blacksburg, Va.