

George Daley, Supplementary Fig. 1

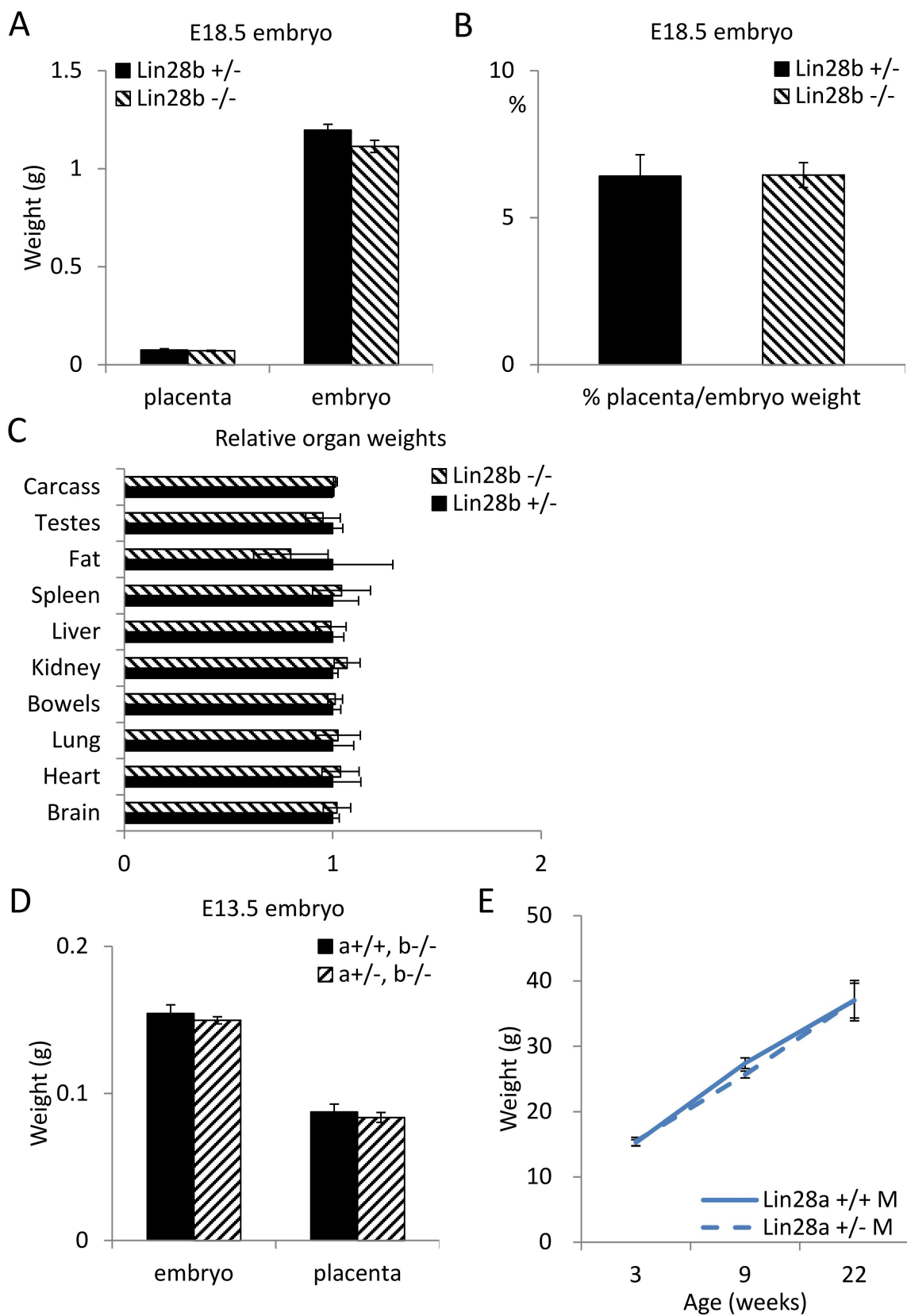

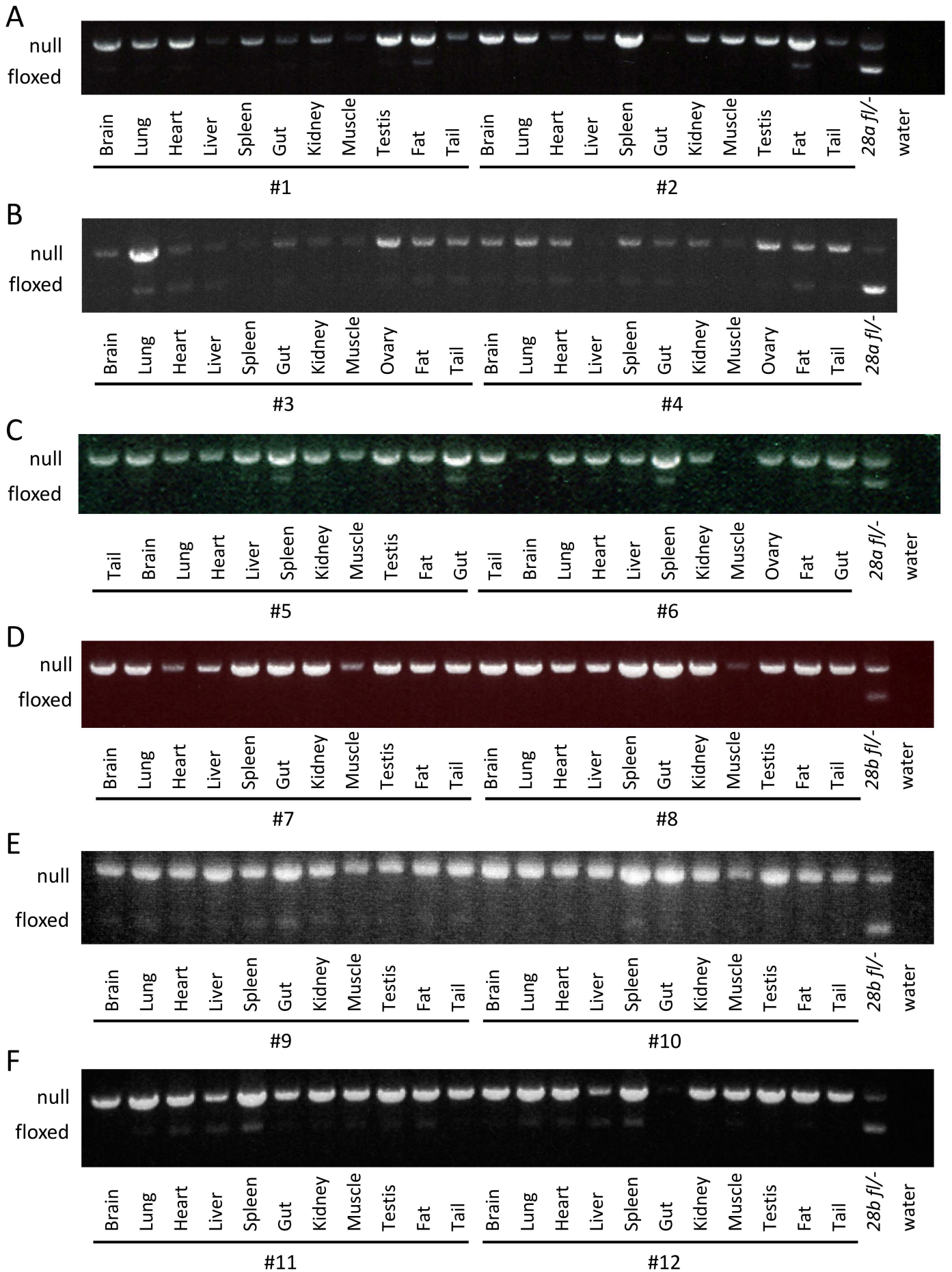

George Daley, Supplementary Fig. 3



George Daley, Supplementary Fig. 4

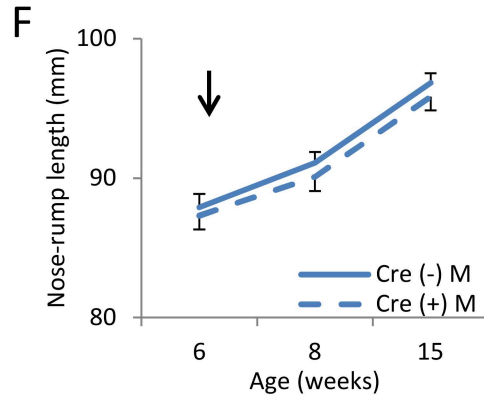
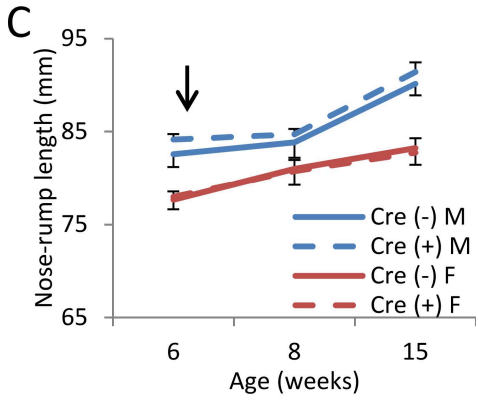
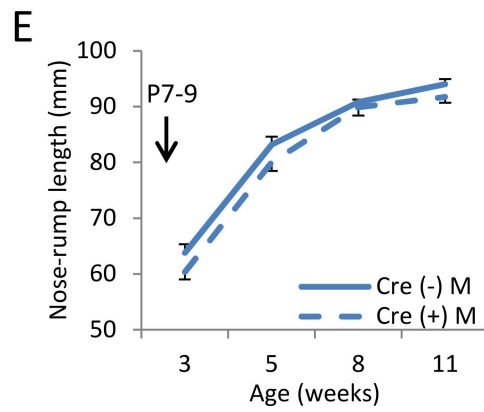
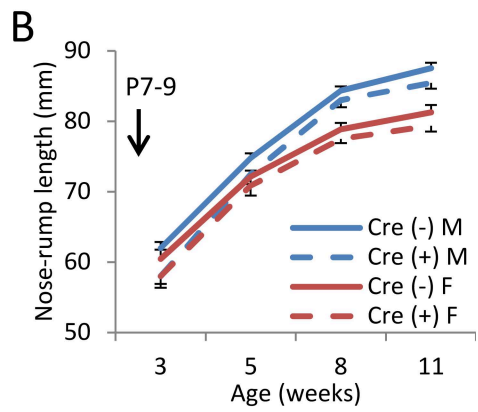
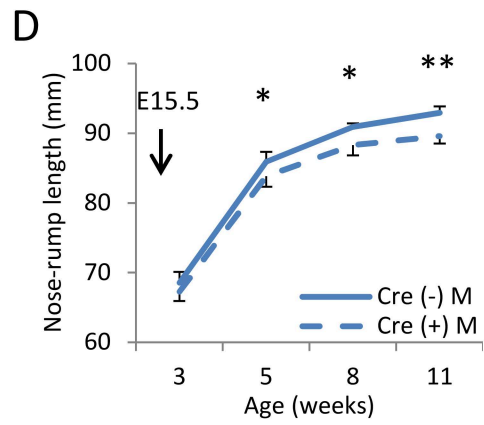
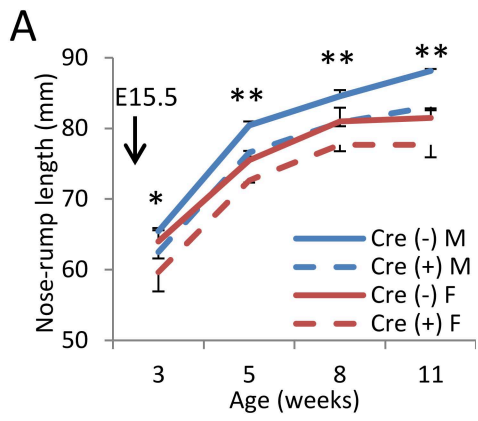

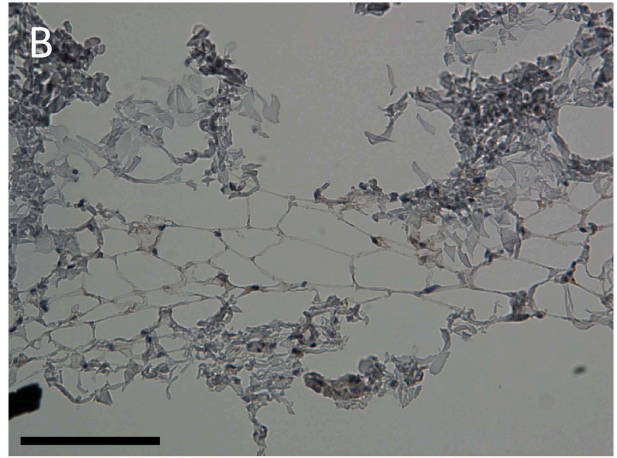
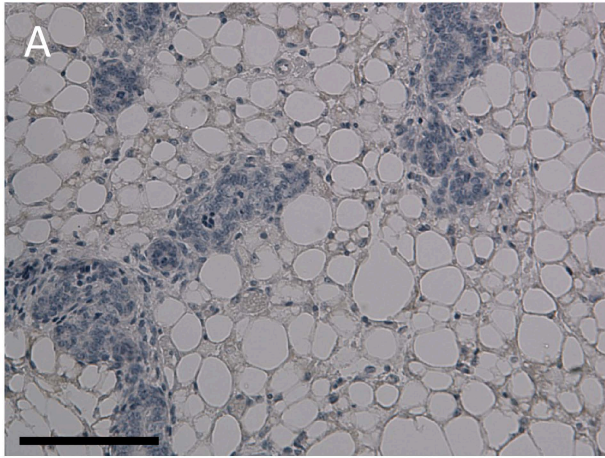

George Daley, Supplementary Fig. 6

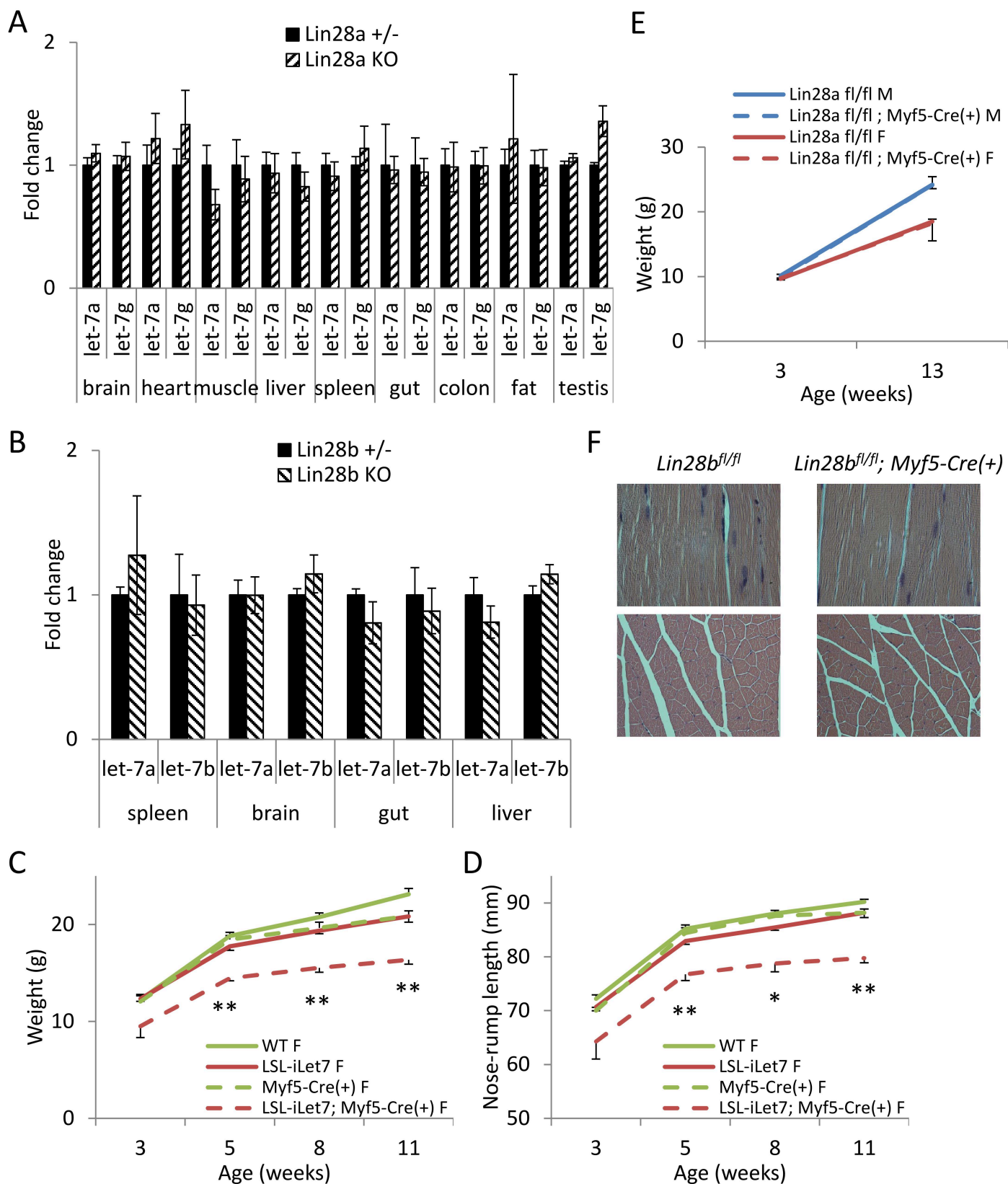

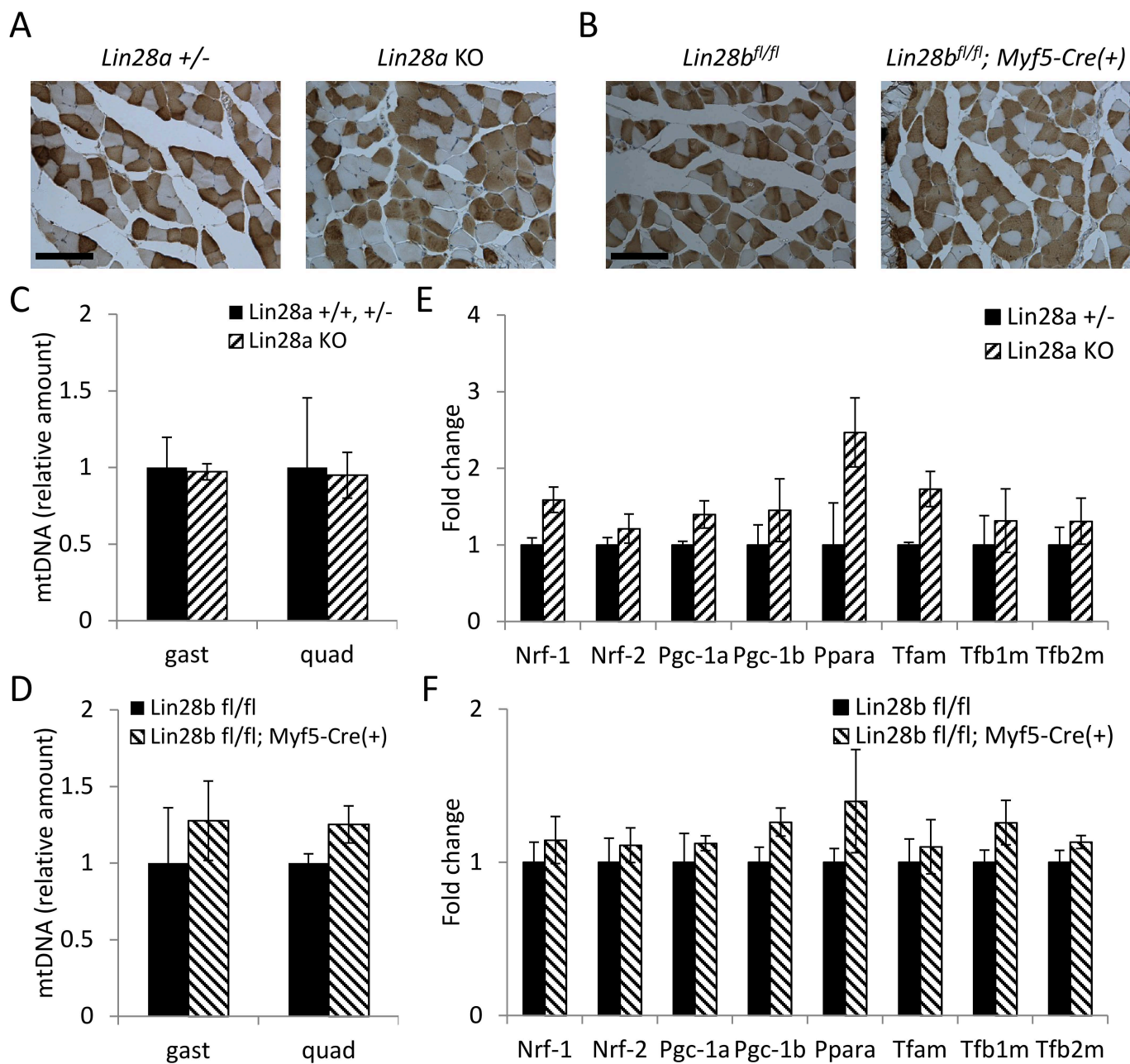



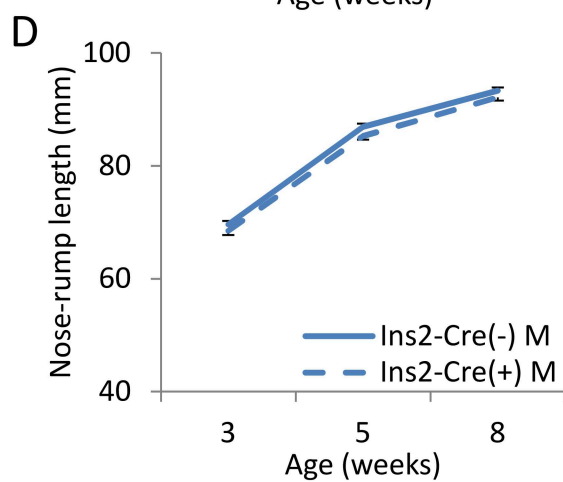
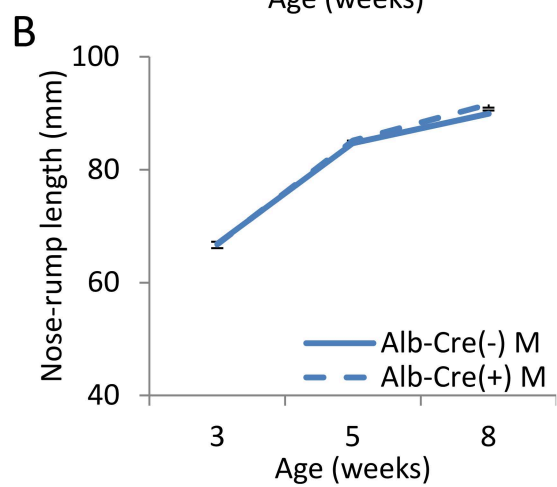
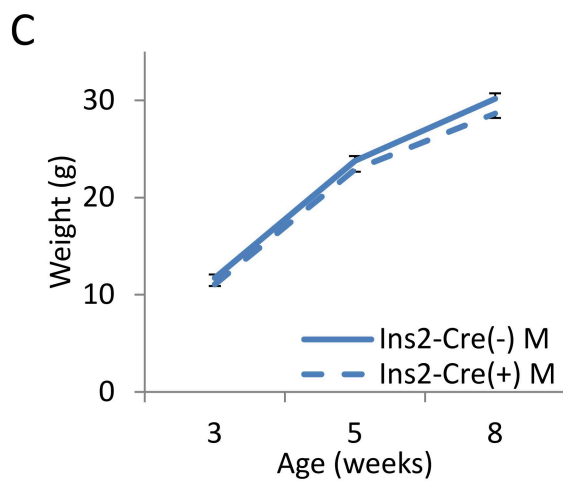
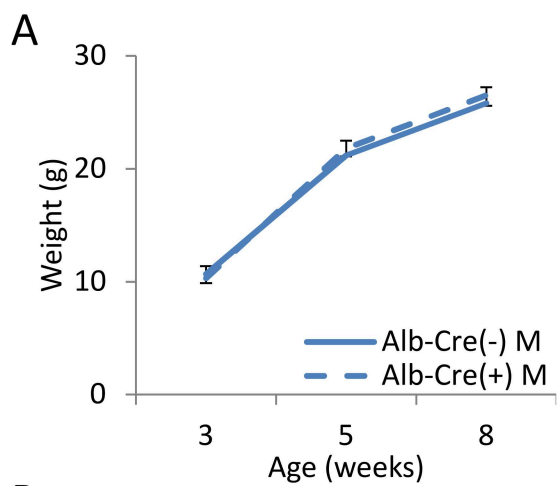

A

*Lin28b* locus

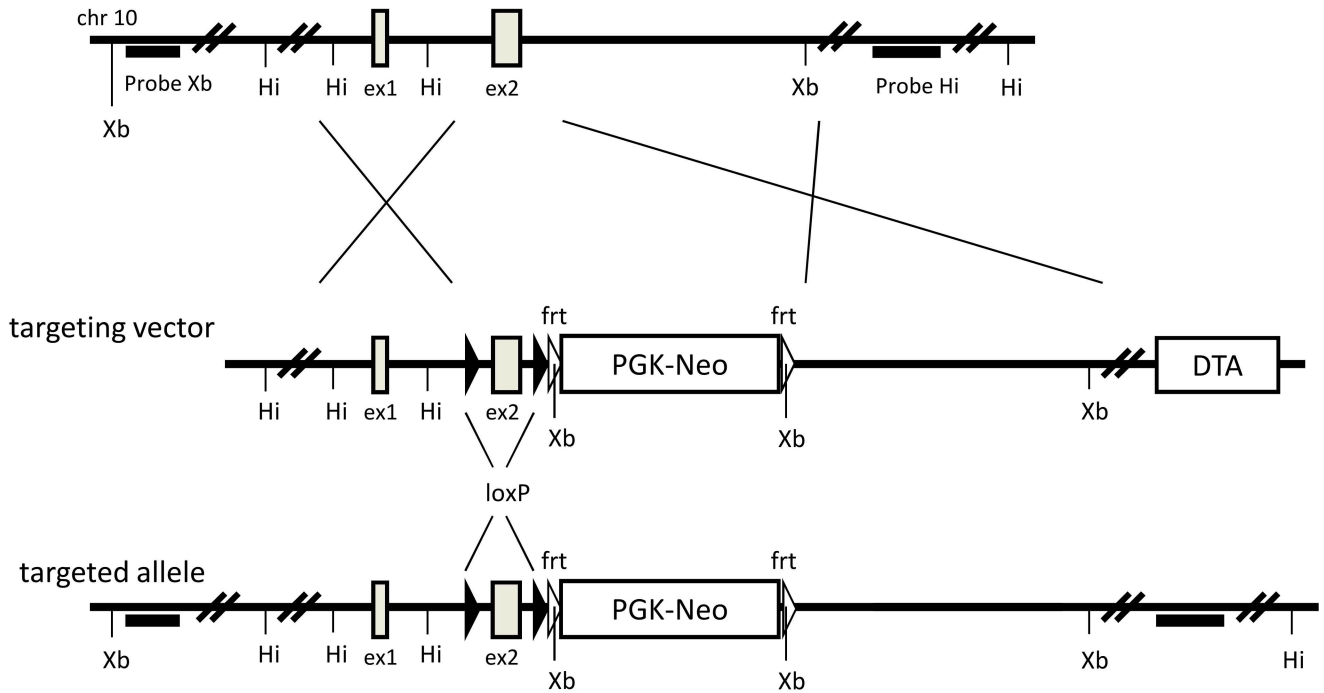

B

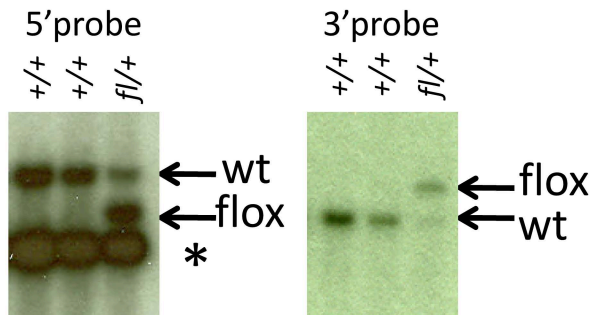

C

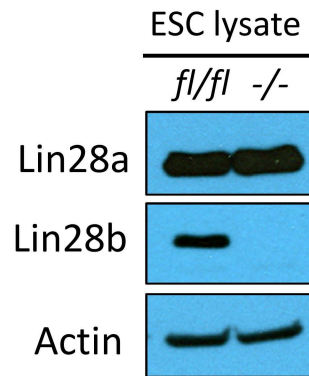

D

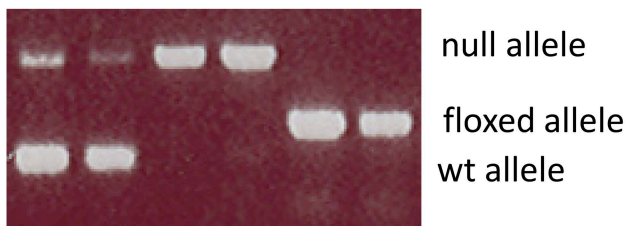

Embryonic day	<i>a</i> +/ <i>+</i> <i>b</i> -/-	<i>a</i> +/- <i>b</i> -/-	<i>a</i> -/- <i>b</i> -/-	resorbed	p value
8.5	8	13	7	0	0.9421
9.5	9	29	14(1)	3	0.6768
10.5	27	64(3)	16	2	0.2065
11.0	7	12	3	1	0.6285
11.5	8	15	14(11)	2	0.4702
12.5	6	18	4(4)	3	0.0273
13.5	9	15	1(1)	1	0.0364