

**Comparative genome mapping between Chinook salmon (*Oncorhynchus tshawytscha*) and rainbow trout (*O. mykiss*) based on homologous microsatellite loci.**

Kerry A. Naish<sup>1\*</sup>, Ruth B. Phillips<sup>2</sup>, Marine S.O. Briec<sup>1</sup>, Lyndsay R. Newton<sup>1</sup>, Anna E. Elz<sup>3</sup>, Linda K. Park<sup>3</sup>

<sup>1</sup>School of Aquatic and Fishery Sciences, University of Washington, Seattle, WA, USA, 98195

<sup>2</sup>Washington State University-Vancouver, Vancouver, WA, USA, 98686

<sup>3</sup>NOAA NMFS NWFSC Conservation Biology Division, 2725 Montlake Blvd. E. Seattle, WA, USA, 98112

\*Corresponding Author: Telephone +1 20-6 221 7375, Fax 1 206 543 5728, email [knaish@uw.edu](mailto:knaish@uw.edu)

**DOI: 10.1534/g3.113.008003**

### Ck01

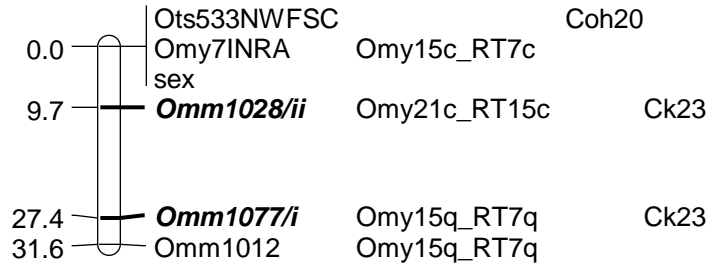

### Ck02

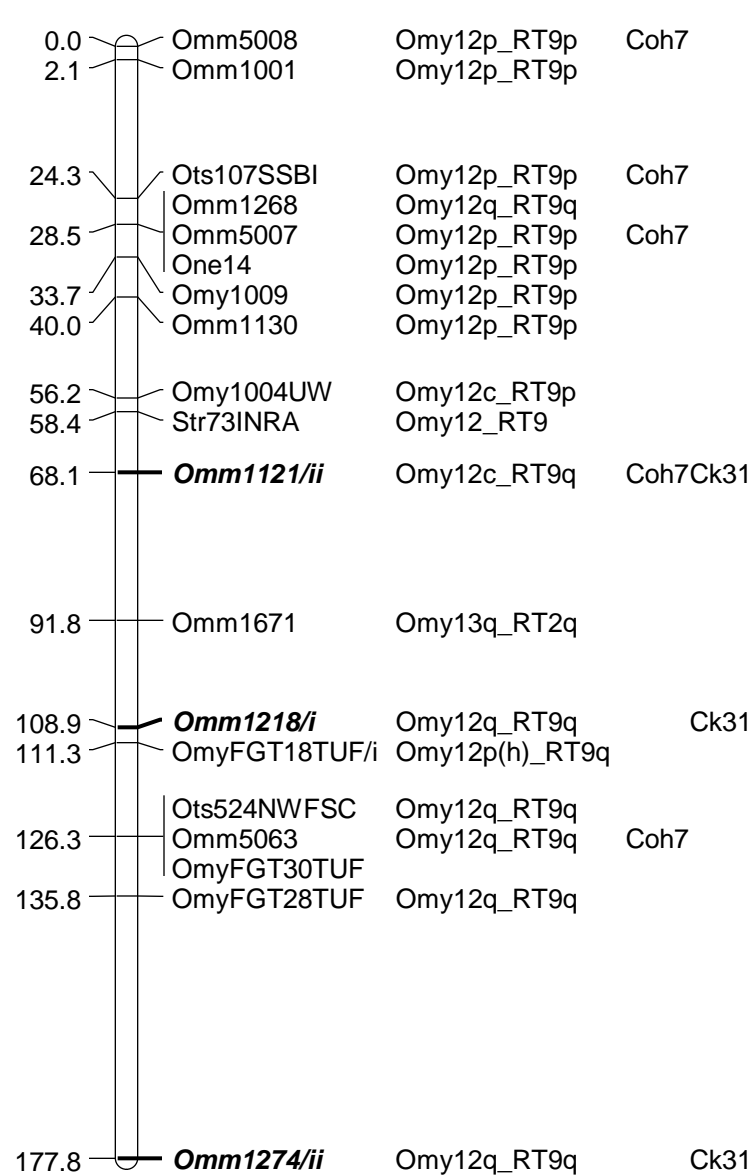

### Ck03

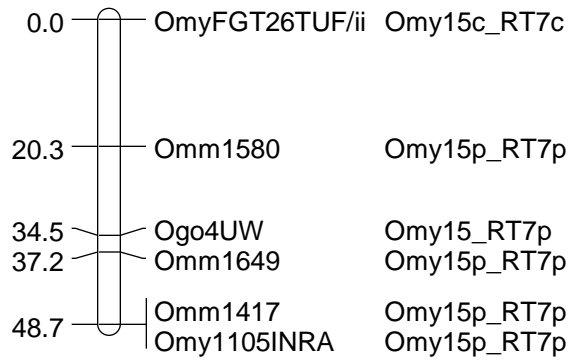

### Ck04

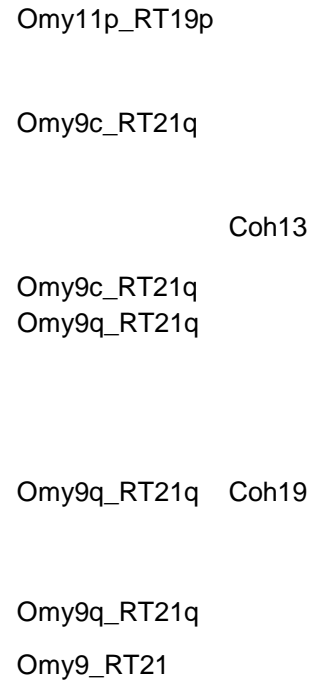
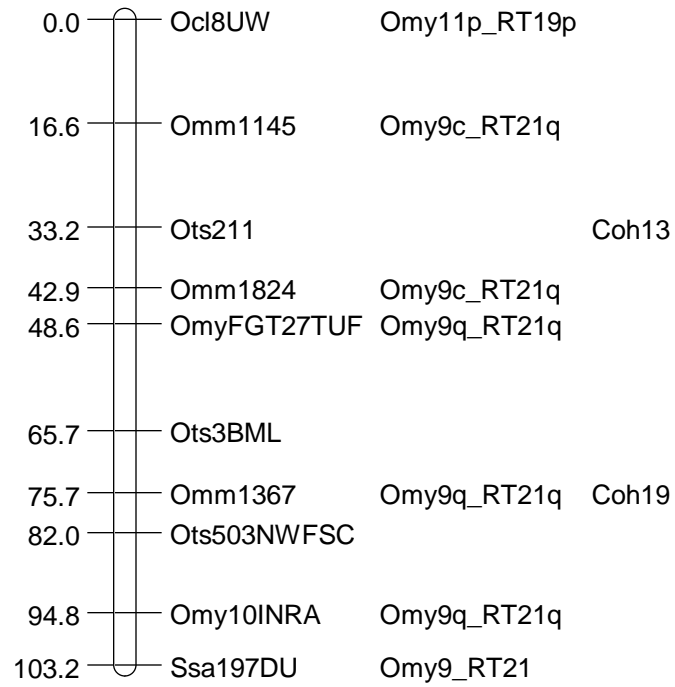

## Ck05

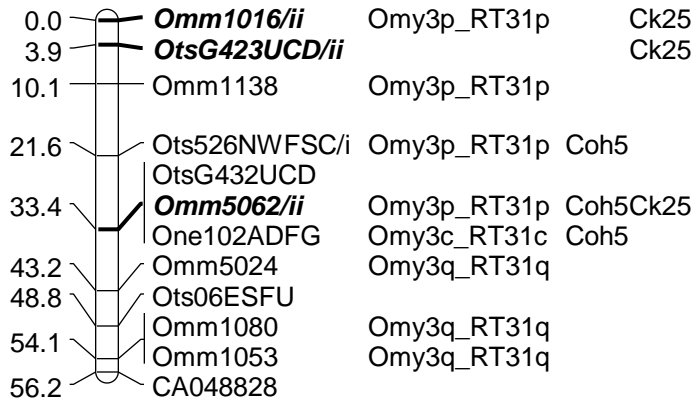

## Ck06

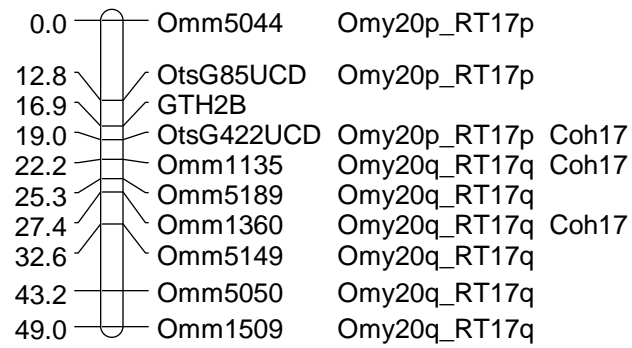

## Ck07

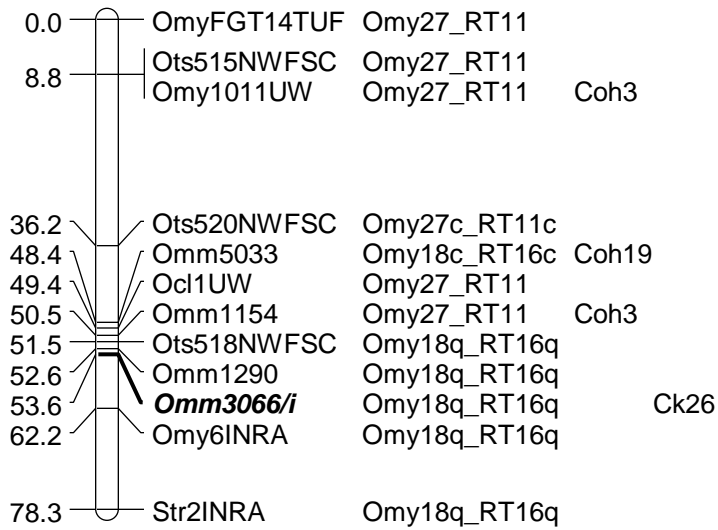

## Ck08

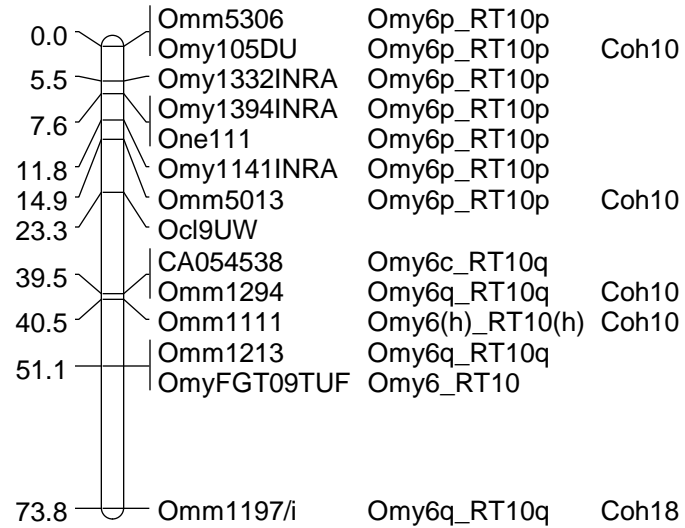

### Ck09

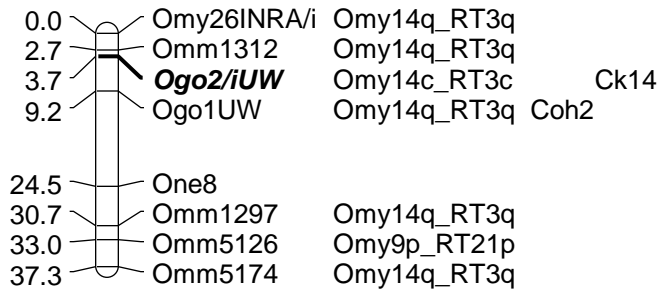

### Ck10

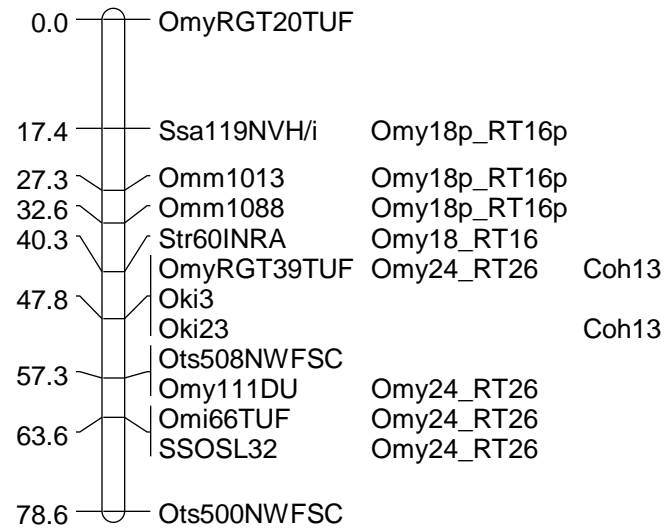

## Ck11

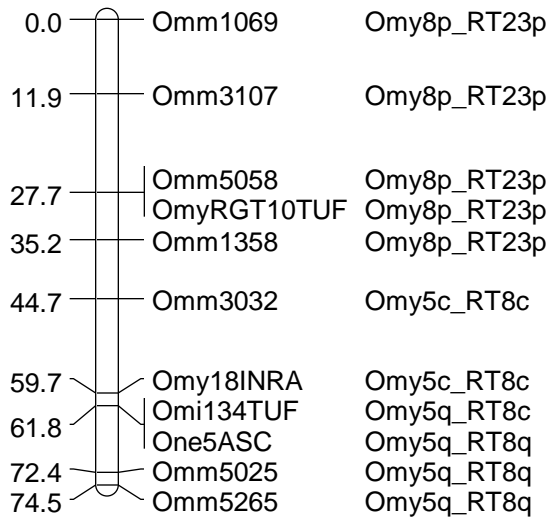

## Ck12

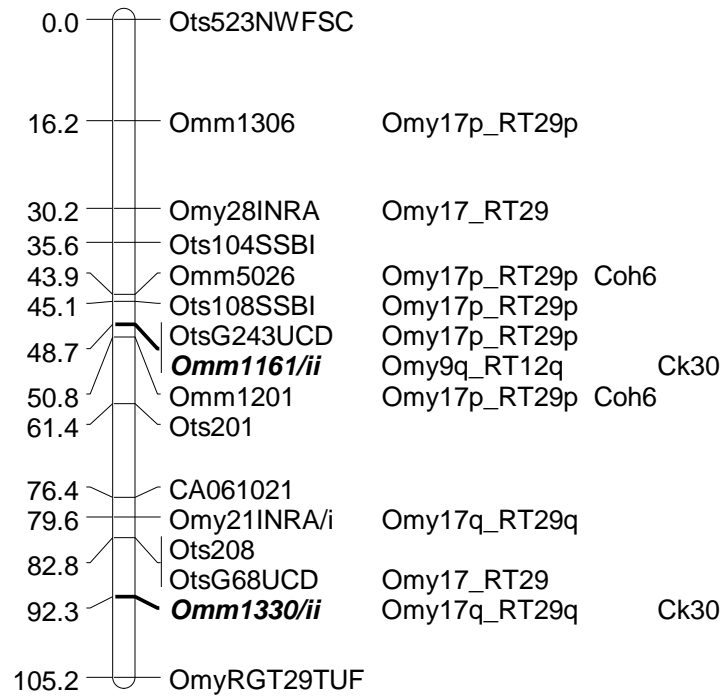

### Ck13

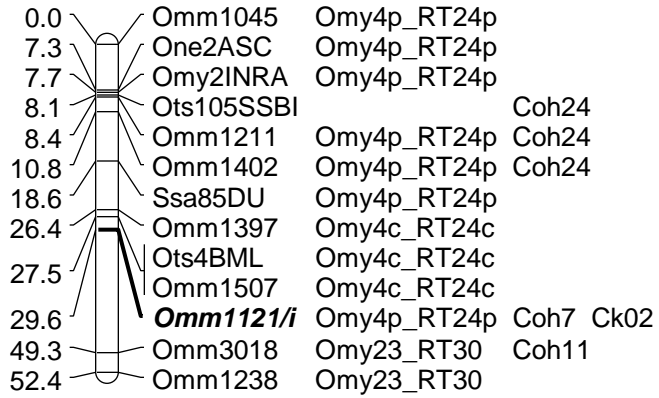

### Ck14

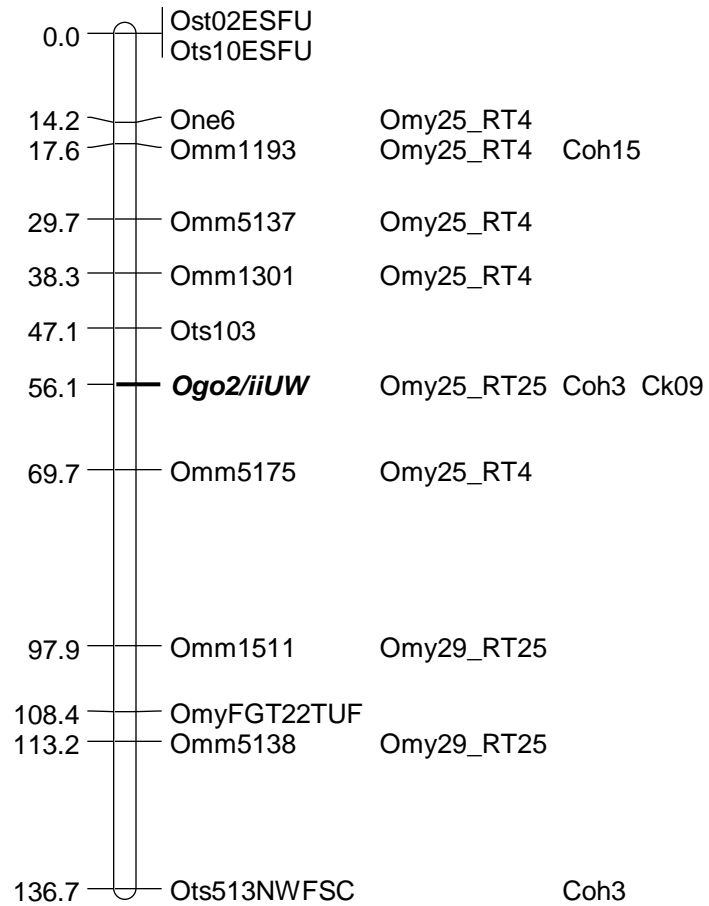



## Ck15

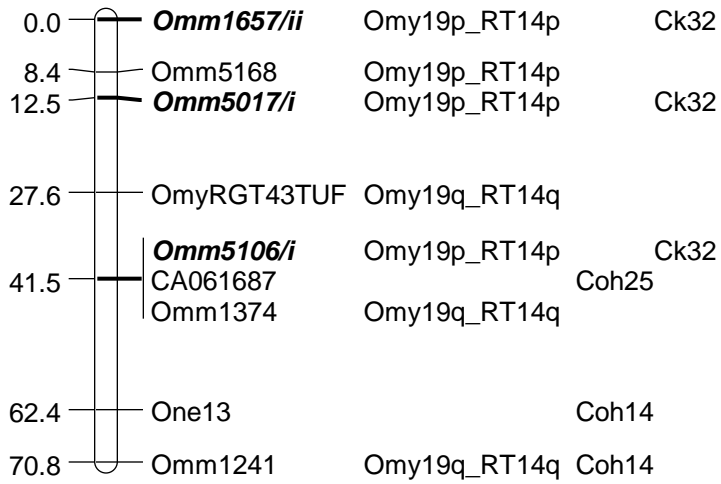

## Ck16

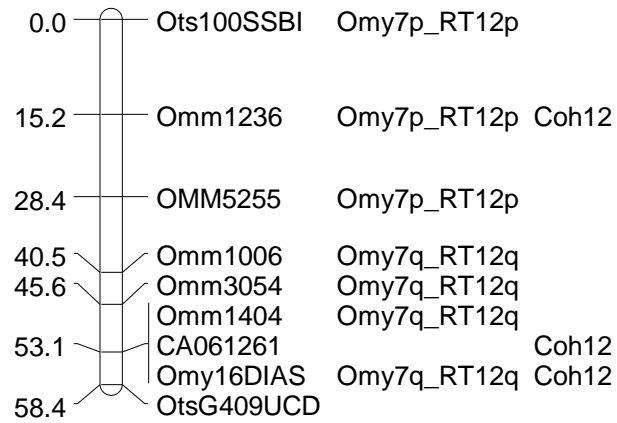

### Ck17

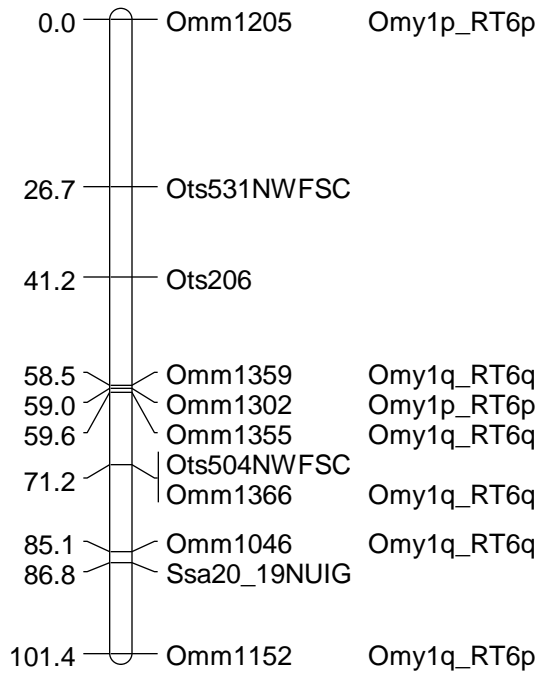

### Ck18

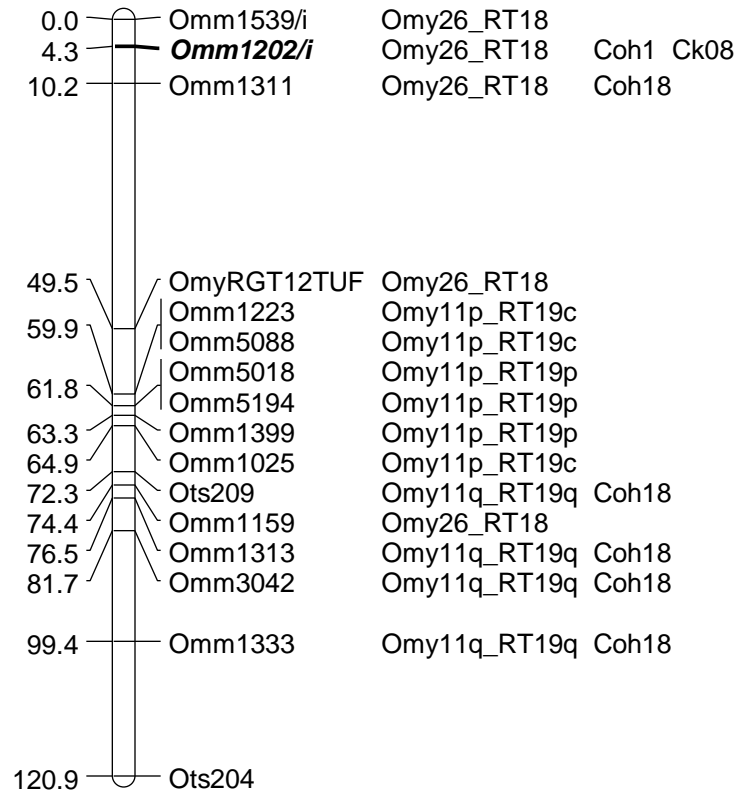

## Ck19

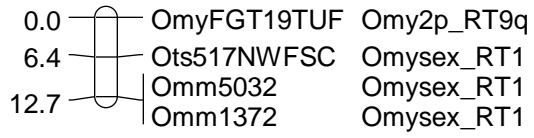

## Ck20

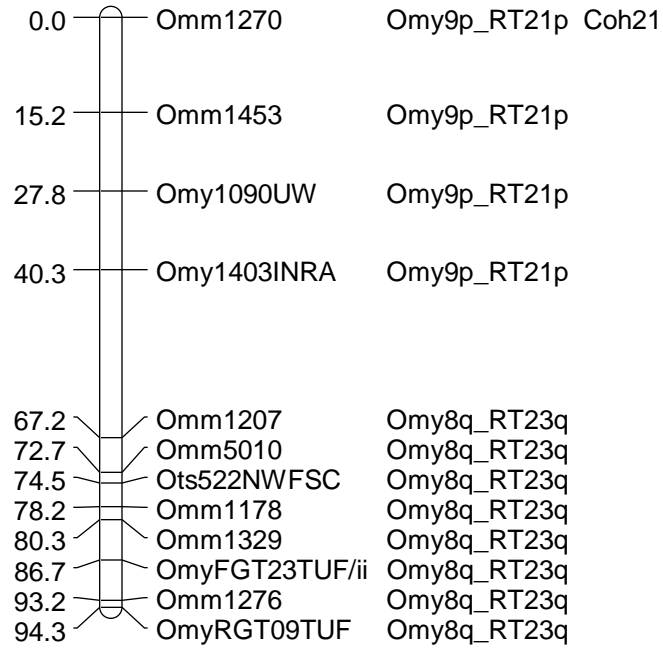

## Ck21

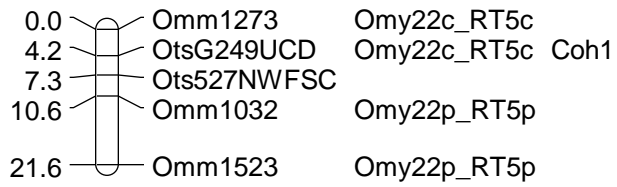

## Ck22

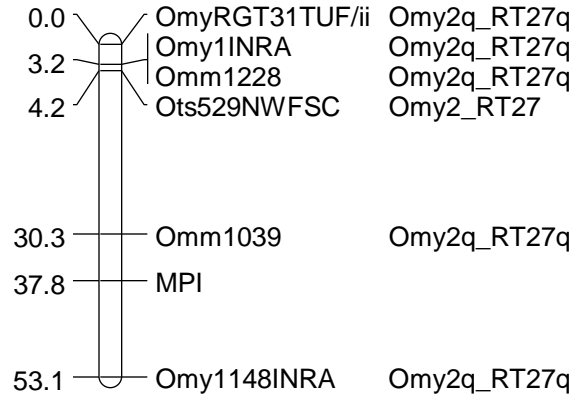

### Ck23

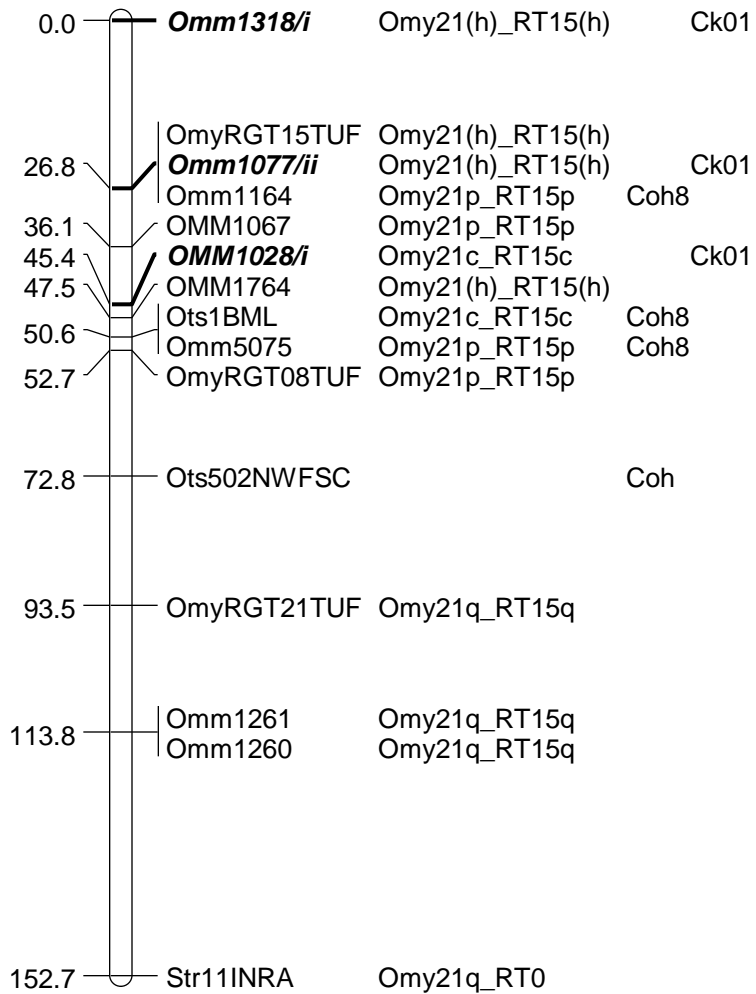

### Ck24

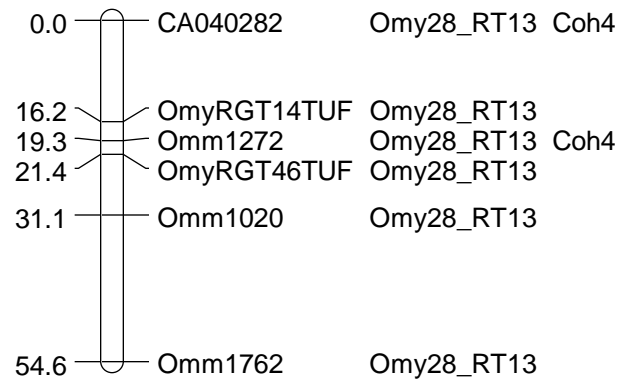

## Ck25

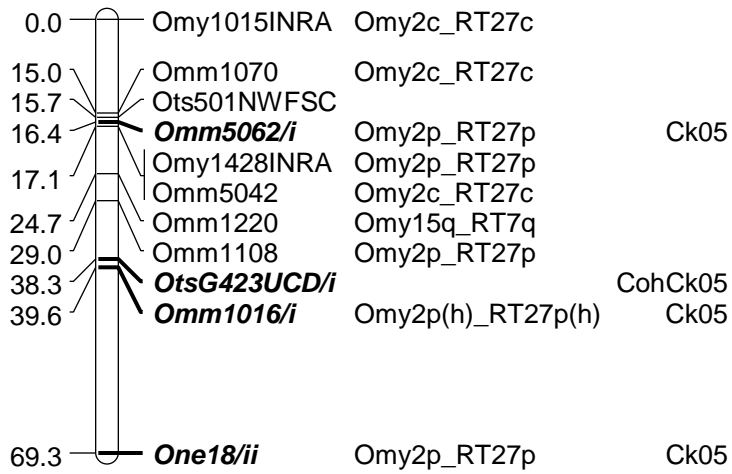

## Ck26

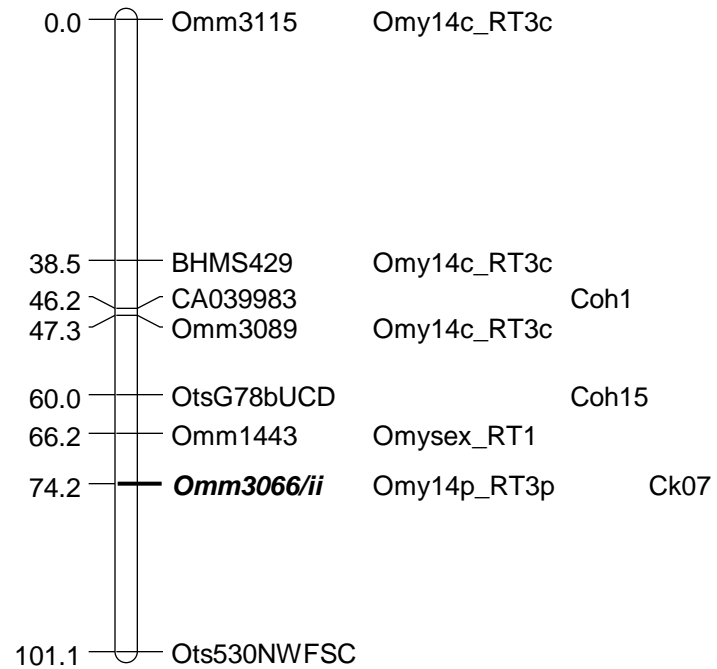

### Ck27

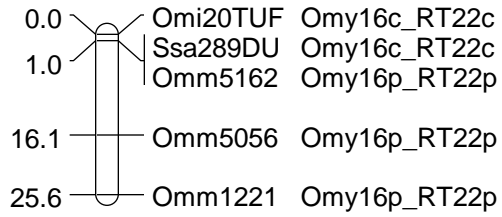

### Ck28

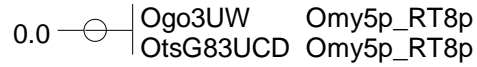

### Ck29

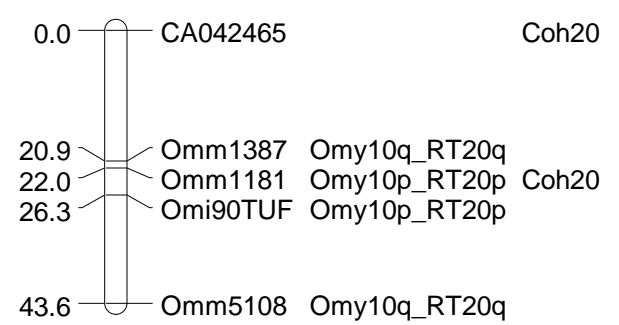

### Ck30

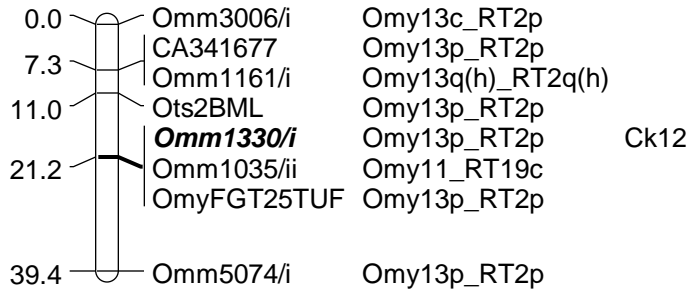

### CkF31

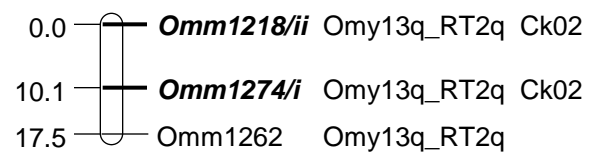



### CkM31

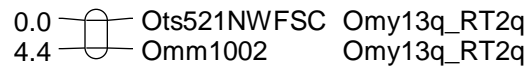

### Ck32

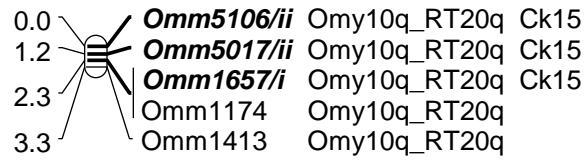

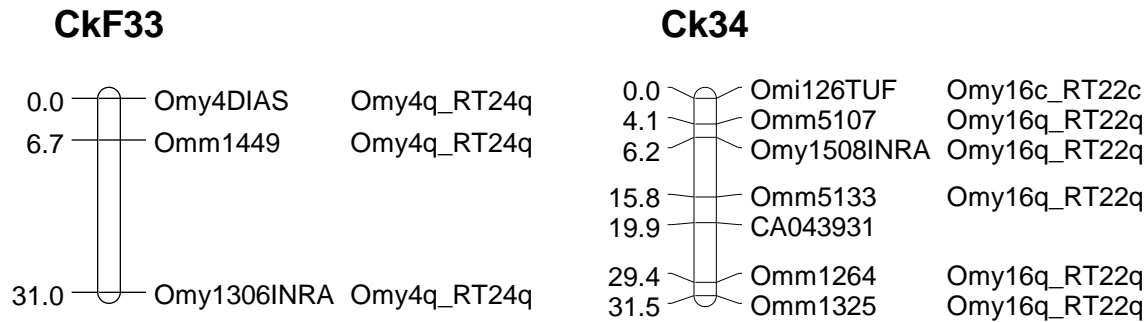

**Figure S1** Graphic representation of linkage groups mapped in Chinook salmon. The map is a consensus of marker order and distances between the female and male parents. Recombination distances are in centiMorgan (Kosambi). Loci are annotated with the chromosome (Omy) or linkage group (RT) assignment in rainbow trout. Rainbow trout chromosome arms (p or q) or centromere positions (c) are identified where possible. Markers that mapped to the homoelog in rainbow trout are designated (h). Duplicated loci (**bold**) are identified as/i or /ii and annotated with the homeologous Chinook linkage groups where both loci are mapped.

Tables S1-S10 are available for download at <http://www.g3journal.org/lookup/suppl/doi:10.1534/g3.113.008003/-/DC1>

**Table S1 Details on microsatellite loci that were polymorphic in the Chinook salmon mapping family.** Marker sources, Genbank accession numbers, primer sequences and annealing temperatures are given for each locus.

**Table S2 Assignment of microsatellite markers to Chinook salmon linkage groups.** Details given are sex in which the marker was mapped, assignment of the marker to rainbow trout chromosomes (Omy) and linkage group (RT), and the source publication in which the marker was mapped in rainbow trout. Marker position in the coho map is also given.

**Table S3 Marker order in the Chinook salmon consensus map.** Details given are marker distances in centiMorgan (Kosambi distance), assignment of the marker to rainbow trout chromosomes (Omy) and linkage group (RT), and the source publication in which the marker was mapped in rainbow trout. Marker position in the coho map is also given.

**Table S4 Marker order in the Chinook salmon female map.** Details given are marker distances in centiMorgan (Theta and Kosambi distance), assignment of the marker to rainbow trout chromosomes (Omy) and linkage group (RT), and the source publication in which the marker was mapped in rainbow trout. Marker position in the coho map is also given. Some linkage groups were incomplete compared to the male map; therefore “sub” linkage groups are designated a, b, or c.

**Table S5 Marker order in the Chinook salmon male map.** Details given are marker distances centiMorgan (Theta and Kosambi distance), assignment of the marker to rainbow trout chromosomes (Omy) and linkage group (RT), and the source publication in which the marker was mapped in rainbow trout. Marker position in the coho map is also given. Some linkage groups were incomplete compared to the female map; therefore “sub” linkage groups are designated a, b, or c.

**Tables S6 Mapchart code for the consensus and sex-specific maps in Chinook salmon.**

**Table S7 Mapchart code for the consensus and sex-specific maps in Chinook salmon.**

**Table S8 Female to male recombination ratios between shared markers in each Chinook salmon linkage group.** Given are map distances in centiMorgan in each of the sexes, recombination ratios and significance detected using a G test (1 df).

**Table S9 Comparison between Chinook salmon, rainbow trout and Atlantic salmon linkage group or chromosome arm arrangements.** Putative chromosome structure in Chinook salmon is given, since exact arm assignments are unknown.

**Table S10 Genotypes for parents and offspring in the mapped family, provided for each microsatellite locus.**