

SUPPLEMENT

CONTROL GROUP ANEMIA MANAGEMENT PROTOCOL

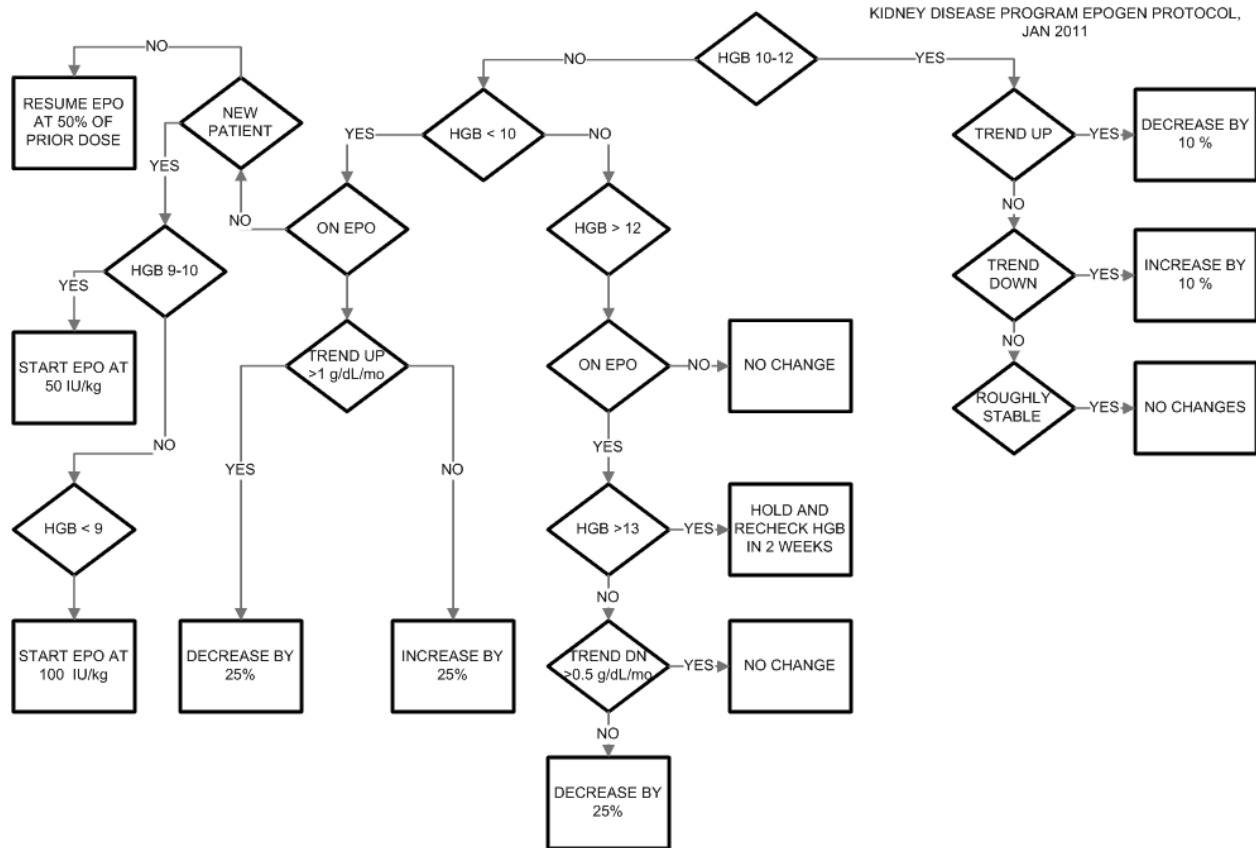

SMART ANEMIA MANAGER*

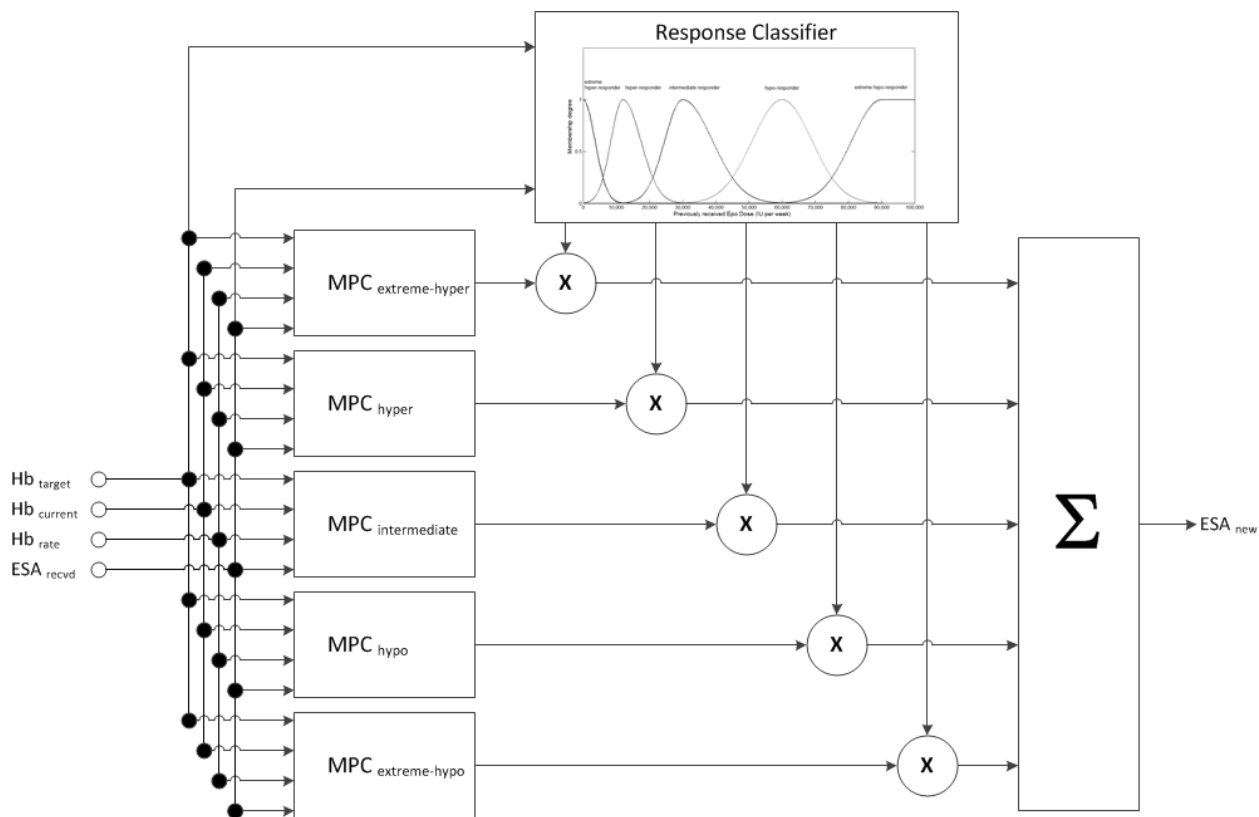

Legend:

MPC	Model Predictive Controller
Hb_{target}	Target Hb concentration [g/dL]
$Hb_{current}$	Current Hb concentration [g/dL]
Hb_{rate}	Hb rate of change [g/dL/mo]
$Epo_{received}$	Average Epo dose received [1,000 IU/week]
Epo_{new}	New recommended Epo dose [1,000 IU/week]

At each dosing step, Response Classifier calculates the matching degree between the patient and one of five dose-response profiles: “extreme hyper-responder”, “hyper-responder”, “intermediate responder”, “hypo-responder”, “extreme hypo-responder”. Dose-response profiles are defined based on Epo dose received to achieve target Hb.

For $Hb_{target} = 11$ g/dL:

1. “extreme hyper-responder” requires approximately 0 to 6,000 IU/week.
2. “hyper-responder” requires approximately 6,000 to 21,000 IU/week.
3. “intermediate responder” requires approximately 21,000 to 45,000 IU/week.
4. “hypo-responder” requires approximately 45,000 to 75,000 IU/week.
5. “extreme hypo-responder” requires more than 75,000 IU/week.

An individual patient may have response characteristics that place them on the border of two types. This is why we use the idea of “approximate dose”. In SAM, it is implemented using fuzzy sets. If patient has not received any Epo, they are classified as extreme hyper-responder, i.e. initiated on a low dose.

*Patent Pending

STUDY DESIGN – COMPROMISE POWER ANALYSIS

Primary Outcome (% Hgb 10-12 over 12 months)

Fisher's Exact Test, Proportions, Inequality, two independent groups, one tail

Statistical significance threshold $p = 0.05 / 12 = 0.0042$

$\beta / \alpha = 0.20 / 0.0042 = 48$

$P1 = 0.6, P2 = 0.7, P2 - P1 = 0.1$

Total Number of Subjects	Total Sample Size	α	$1 - \beta$
40	480	0.0104	0.50
50	600	0.0087	0.58
60	720	0.0072	0.64
70	840	0.0060	0.70
80	960	0.0051	0.75
90	1080	0.0042	0.79
100	1200	0.0035	0.82

POST-HOC POWER ANALYSIS

Primary Outcome (% Hgb 10-12 over 12 months)

Proportions: Inequality, two independent groups (Fisher's exact test)

Tail(s)	=	One
Proportion p1	=	0.619
Proportion p2	=	0.725
α err prob	=	0.003
Sample size group 1	=	336
Sample size group 2	=	356
Power (1- β err prob)	=	0.5539150
Actual α	=	0.002382717

Secondary Outcome (% Hgb < 10 over 12 months)

Proportions: Inequality, two independent groups (Fisher's exact test)

Tail(s)	=	One
Proportion p1	=	0.247
Proportion p2	=	0.118
α err prob	=	0.001
Sample size group 1	=	336
Sample size group 2	=	356
Power (1- β err prob)	=	0.8975209
Actual α	=	0.0006749798

Secondary Outcome (% Hgb > 12 over 12 months)

Proportions: Inequality, two independent groups (Fisher's exact test)

Tail(s)	=	One
Proportion p1	=	0.134
Proportion p2	=	0.157
α err prob	=	0.391
Sample size group 1	=	336
Sample size group 2	=	356
Power (1- β err prob)	=	0.6824050
Actual α	=	0.3525869