

Supplementary Figure 1

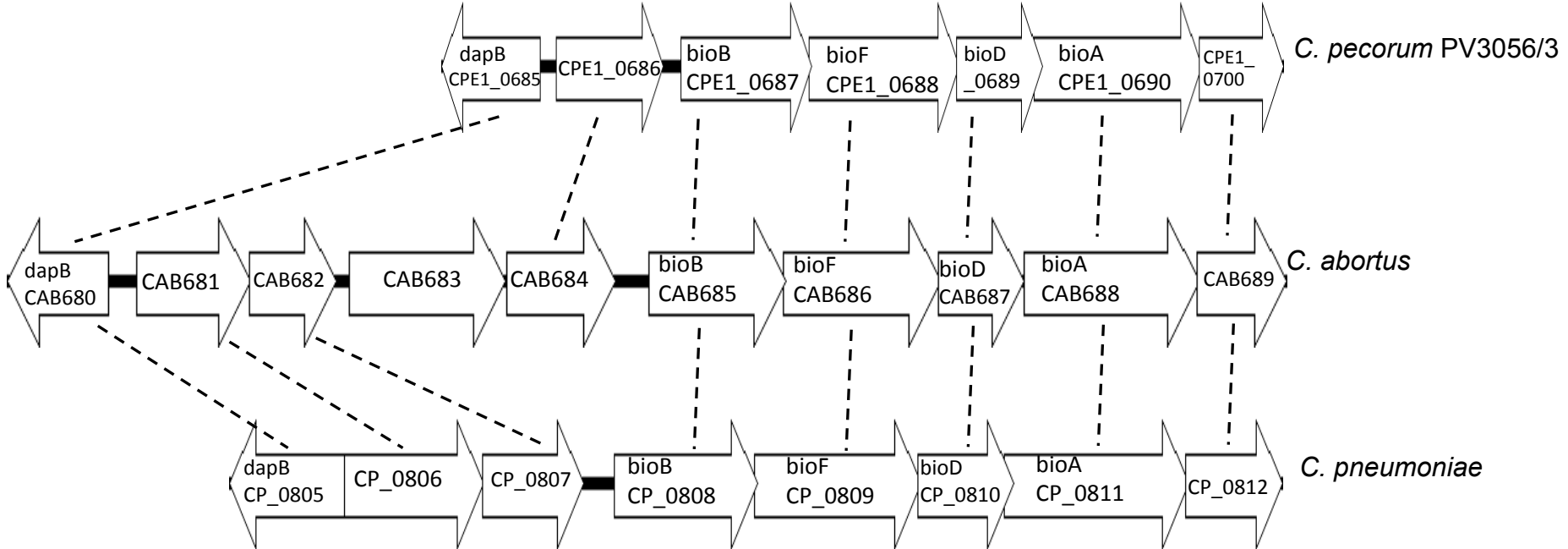

Supplementary Figure 3

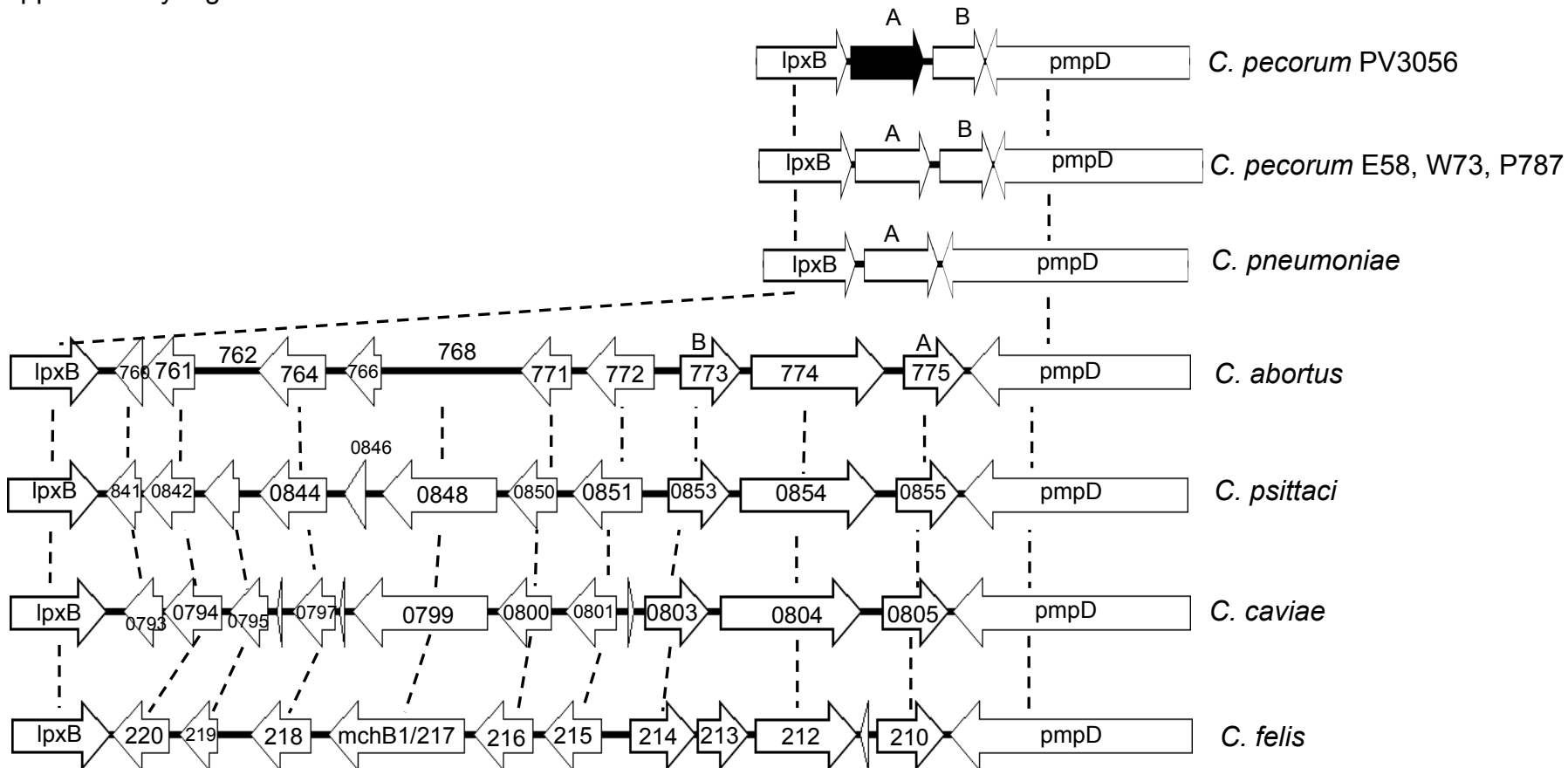

Supplementary Figure 4

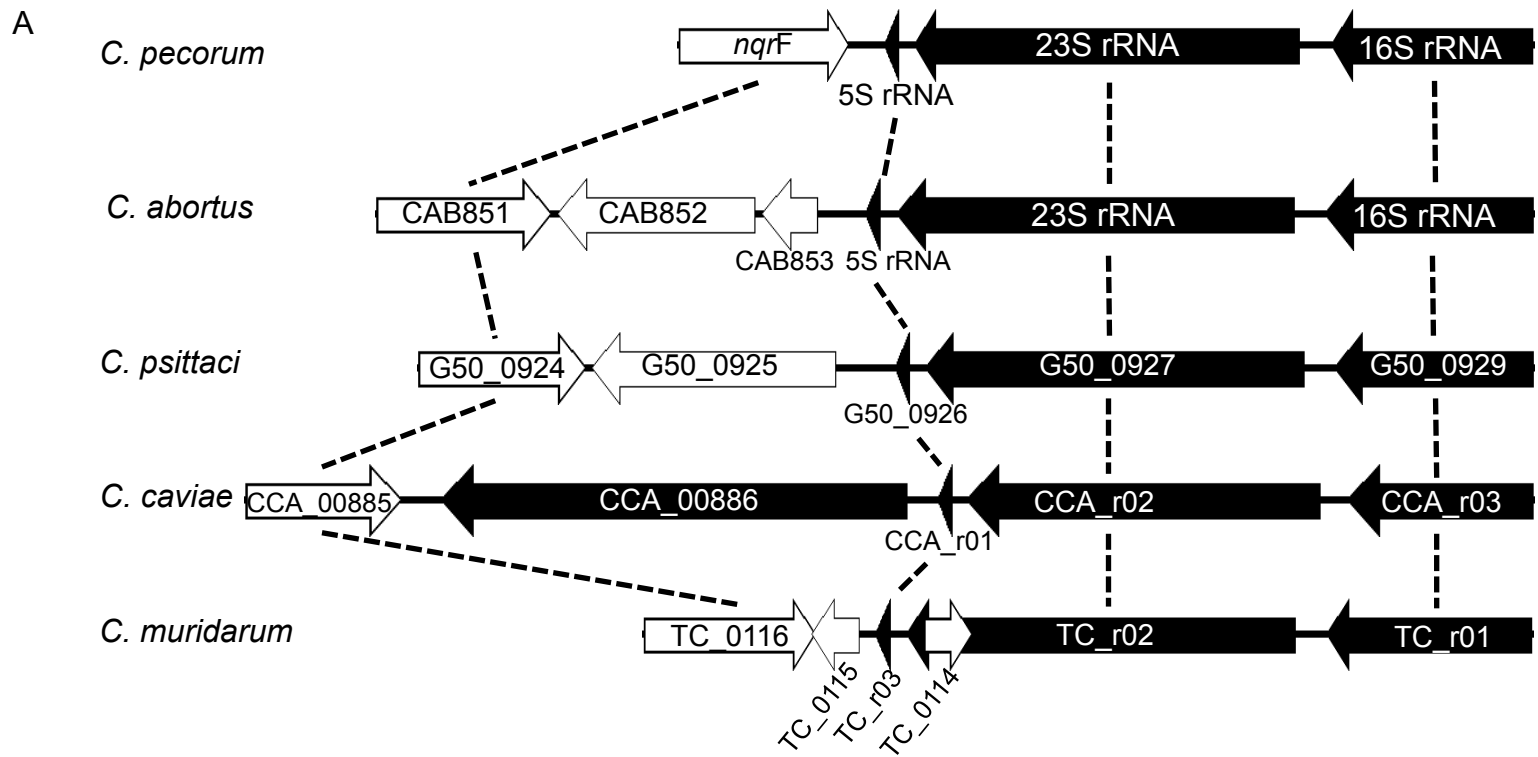

B

PV3056/3	AAAATAAGGC	TATTTTCTAG	-CTTTTTTTT	ATAGACACTC	TTTACCTCC	-----AAA	GCACTAAAGC	ACTAAAGCAC	TAAAGCACTA	AAGCACTAAA
W73	AAAATAGCCT	TATTTTCTAG	-CTTTTTTTT	ATAGACACTC	TTTACCTCC	-----AAA	GCACTAAAGC	ACTAAAGCAC	TAAAGCACTA	AAGCACTAAA
P787	AAAATAGCCT	TATTTTCTAG	-CTTTTTTTT	ATAGACACTC	TTTACCTCCA	AAGCACTAAA	GCACTAAAGC	ACTAAAGCAC	TAAAGCACTA	AAGCACTAAA
E58	AAAATAGCCT	TATTTTCTAG	TTTTTTTTTT	ATAGACACTC	TTTACCTCC	-----AAA	GCACTAAAGC	ACTAAAGCAC	TAAAGCACTA	AAGCACTAAA
PV3056/3	GCACTAAAGC	ACTAAAGCAC	TAAAGCACTA	AAGCACTAAA	GCACTAAAGC	ACTAAAGCAT	AAAATTTAGT	TGAGTCGCAG	AAAAATATGA	AAC-AAAAAA
W73	GCACTAAAGC	ACTAAAGCAC	TAAAGCACTA	AAGCACTAAA	GCACTAAAGC	ACTAAAGCAT	AAAATTTAGT	TGAGTCGCAG	AAAAATATGA	AAC-AAAAAA
P787	GCACTAAAGC	ACTAAAGCAC	TAAAGCACTA	AAGCACTAAA	GCACTAAAGC	ACTAAAGCAT	AAAATTTAGT	TGAGTCGCAG	AAAAATATGA	AAC-AAAAAA
E58	GCACTAAAGC	ACTAAAGCAC	TAAAGCACTA	AAGCACTAAA	GCACTAAAGC	ACTAAAGCAT	AAAATTTAGT	TGAGTCGCAG	AAAAATATGA	AACAAAAAAA
PV3056/3	AAGAGAACAA	AATCGCTTTT	GTCCTCTTTT	CTTAAACTTA	GTCTTATGAC	CAAGGAATCT	TTTATATAAA	A-		
W73	AAGAGAACAA	AATCGCTTTT	GTCCTCTTTT	CTTAAACTTA	GTCTTATGAC	CAAGGAATCT	TTTATATAAA	A-		
P787	AAGAGAACAA	AATCGCTTTT	GTCCTCTTTT	CTTAAACTTA	GTCTTATGAC	CAAGGAATCT	TTTATATAAA	A-		
E58	AAGAGAACAA	AATCGCTTTT	GTCCTCTTTT	CTTAAACTTA	GTCTTATGAC	CAAGGAATCT	TTTATATAAA	AA		