

THE POROMETER METHOD FOR THE CONTINUOUS ESTIMATION OF DIMENSIONS OF STOMATES

CHARLES C. WILSON

(WITH FOUR FIGURES)

Received July 10, 1946

In studies concerning the movement of gases and vapors into and out of the leaf, it is frequently necessary that the dimensions of the stomates be determined. Such information may be more useful if it consists of a continuous record of the stomatal aperture rather than a series of periodic measurements. Two methods are generally used for the procurement of such continuous data; direct microscopic measurement and the porometer.

Direct microscopic measurement of the dimensions of the stomates has been considered the most accurate method by many workers. There are, however, several difficulties which make accurate measurements by the microscope difficult. For certain leaves, under some conditions, accurate measurements can be made only with extreme difficulty. For other leaves, the microscope cannot be used at all. The method is not well adapted for continuous observation, because of the strain imposed upon the worker and because of undesired changes induced through mechanical manipulation and the use of light. Also, since only a few stomates can be measured at one time, the question arises as to whether they constitute a representative sample or reflect correctly the average stomatal aperture. However, when employed for the determination of the dimensions of the stomates at a particular instant, a high degree of accuracy may be achieved.

The porometer is a device used to measure changes in the rate of flow of air through the leaf. A cup or tube is attached to the leaf and the pressure of the air within the cup is either raised or lowered with respect to normal air pressure. It is assumed that the changes in the rate of air flow are directly proportional to the changes in the dimensions of the stomates.

The porometer was first proposed by Dutrochet in 1832, according to DARWIN and PERTZ (3). In 1876, Muller constructed an apparatus employing this principle which proved too complicated and cumbersome for general use and acceptance. The modern design for the porometer was developed by DARWIN and PERTZ (3). Improvements were made on this type of porometer by KNIGHT (7), and by LAIDLAW and KNIGHT (9) who devised a constant flow aspirator and made the process self-recording. Other porometers were devised by BALLS (2), and by JONES (6). A porometer which measures changes in the rate of flow of air through the leaves in terms of pressure was devised by GREGORY and PEARSE (4). This method uses small rates of air flow and low pressures. It will be described in detail in another section.

Numerous criticisms have been leveled at this method, many of which are no longer valid in the light of present information. LOFTFIELD (10) considered that until a "comparison has been made between a series of direct observations upon the conditions of the stomata and porometer readings made at the same time—its reliability is questionable."

ASHBY (1) compared readings of a porometer with simultaneous measurements from epidermal strips. He concluded that with large apertures the two methods are essentially measuring the same thing but that with small apertures the porometer method is more than ten times as sensitive. He also found the error of replication of the porometer to be less than 3% while that of the strip method was over 20%. MASKELL (11) compared the porometer rate with the area of the stomates determined from impressions. Although he made only a small number of comparisons, his results indicated a linear relation between porometer time and the area of the stomates.

In a study of the effect of certain gases on permeability of the leaves, PAWLENKA (13) made a great many simultaneous measurements of the stomates using the porometer and the strip method which were reinforced by direct microscopic observations. Although not intended as a check upon the porometer, it affords the most extensive comparative investigation yet reported. Invariably, there was a direct relation between the porometer time and the area of the stomates as determined by the strip method which was constantly checked by direct microscopic observation. HARTSUIJKER (5) after a critical study of the most important methods to determine the dimensions of the stomates, concluded that there was a direct relation between the porometer time and the area of the stomates as measured by direct microscopic observation. He considered that the porometer was an extremely useful device for the quantitative investigation of the changes in the dimensions of the stomates.

The rate of the passage of air through the leaf is also influenced by the resistance of the cells of the mesophyll. If the intercellular volume were to change appreciably during the course of an experiment, the porometer rate would be a reflection of this change as well as of changes in the dimensions of the stomates. NIUS (12) investigated this question and concluded that such changes actually occurred. If Nius' conclusions are correct, a serious and uncontrollable error would affect the accuracy of the porometer method. This question was reinvestigated by HARTSUIJKER (5) who concluded that Nius' methods contained so many errors that his results were not valid. By the use of improved methods of a known small error, he showed that the effect of changes in the intercellular volume is extremely small. The writer has repeated these experiments of Hartsuijker and confirmed his results

KNIGHT (8) showed that some stomates tend to close when air is drawn through them continuously. This difficulty is associated with the use of high pressures and large displacement of volume. If the pressure used is small and the volume of air drawn through the leaf reduced to a minimum,

stomatal action appears to be unaffected. The writer has obtained records from plants growing under controlled conditions in which the stomates, as measured by the porometer, were continuously and evenly open for more than twenty-four hours at a time. It would appear that the method itself, even though used continuously, does not induce closure.

The porometer method has several decided advantages when compared to other methods. All measurements are based on the action of a large number of stomates. For comparable results to be obtained by the direct methods, several thousands of stomates would need to be measured at each reading. Since the porometer reading is determined by the average aperture of the stomates, there is a small standard error of replication. The writer has tested this point repeatedly and has found the error to be within 3%. The small standard error implicit in this method permits accurate measurement of small changes in aperture. A further important advantage is that direct, continuous records of the movements of the stomates may be obtained under either natural or controlled conditions. The writer has obtained continuous records for periods of more than four months from plants growing out-of-doors.

The porometer method for determining the apertures of the stomates is apparently accurate, and suitable for continuous operation. It is felt that the objections which have been raised against this method, are either based on insufficient data or have been met by improvements in the method. It is considered that for most studies dealing with the effects of environmental factors upon the activities of the guard cells, the use of the porometer affords the possibility of accurate continuous quantitative measurement.

The resistance porometer

Since the porometer method has so many advantages, considerable attention was given to the development of a simple, reliable recording instrument. The resistance porometer, devised by GREGORY and PEARSE (4) is considered the most useful for precise continuous measurement of the aperture of the stomates under practical conditions. The apparatus which they used in recording the behavior of the porometer is both cumbersome and expensive and limits the usefulness of the porometer to the laboratory. A recorder was devised by the writer which is simple to operate and inexpensive to construct and has the additional advantage of requiring a very low pressure differential for its operation.

The method may be explained by reference to figure 1. A leaf, which when attached to a leaf cup behaves as a variable resistance, is connected through a fixed capillary resistance to a vacuum line. A tambour which is a flanged metal cup approx. 1" in diameter and $\frac{3}{8}$ " deep, sealed at the top with a thin rubber membrane, is inserted between the leaf cup and the fixed resistance to respond to changes in air pressure in the system. A constant reduced pressure equivalent to about one cm. of water is applied to the open end of the fixed resistance. The magnitude of this pressure is controlled by

the depth to which the spill-over tube is inserted into the liquid in the pressure regulator.

If more air enters through the leaf into the leaf cup than is removed through the capillary resistance, the pressure within the system increases somewhat, causing the tambour membrane to rise. If less air enters through the leaf than is removed through the capillary resistance, the pressure decreases and the tambour membrane falls. Since the stomates control the passage of air through the leaf, the pressure changes reflect the movements of the stomates. As the stomates close, entrance of air is restricted and finally stopped, the pressure decreases and the tambour falls. As the stomates open, air enters the system, the pressure increases, and the tambour rises. The movements of the tambour membrane are transmitted by a

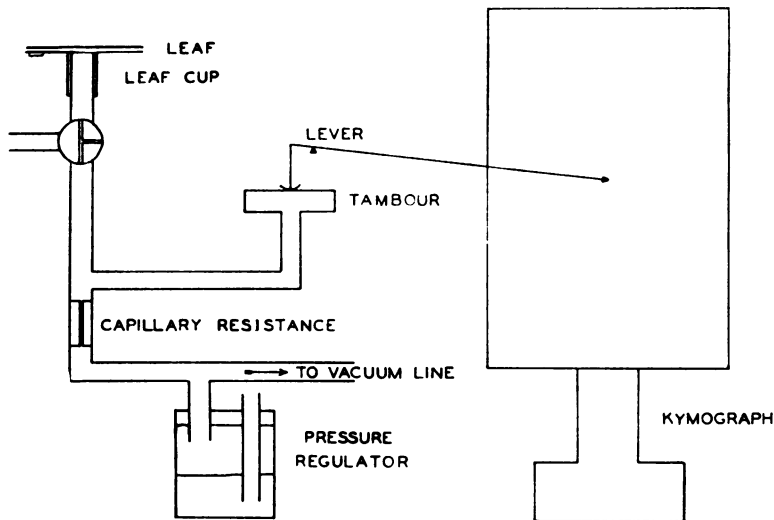

FIGURE 1

FIG. 1. Diagram of resistance porometer showing relation of various parts of system.

multiplying lever to smoked paper on a kymograph drum and a record is thus obtained.

The proper size of capillary resistance can only be ascertained by experimenting. If, as suggested by GREGORY and PEARSE (4), the thermometer tubing used for resistance is cut into segments with lengths in the ratio of 1:2:2:5:10, then a range of resistances from 1 to 20 can be obtained. Student thermometers, cut to a basic unit of 1 cm., were used. A glass T-tube was attached to both ends of each capillary segment. The tubes were then connected by rubber tubing to form a chain consisting of a piece of capillary alternating with a T-tube. Such an arrangement leaves an open end of a T-tube on either side of each piece of thermometer tubing. If these open ends are then joined by a piece of rubber tubing, they form a series of by-passes around each piece of thermometer tubing. However, if one of the

by-passes is closed with a metal clip, the air must pass through the capillary tubing. Thus by regulating the air through either the by-pass or the capillary tube, the total resistance in the circuit may be changed from 1 to 20 without allowing any outside air into the system. If too large a resistance is used, the tambour will register normal pressure while the stomates are still partly closed because air is not being removed as rapidly as it enters. If too small a resistance is used, the tambour will register reduced pressure even when the stomates are wide open because air is being removed more rapidly than it enters. The system is most sensitive when the fixed capillary resistance is equal to the resistance offered by the leaf, but since the leaf resistance varies greatly in the course of a day such a relation cannot be maintained. The proper resistance is one with which the change in pressures between fully open and completely closed stomates is within the total pressure range of the system.

In practice this is most easily attained by adjusting the resistances while the plant is under conditions which generally promote maximum stomatal opening; i.e., a high light intensity, fairly high humidity, and a temperature of between 25° and 30° C. Starting with maximum resistance in the line, the resistance is reduced, until the writing arm moves and then holds steady indicating slightly less than maximum pressure.

The leaf cups which are made of thin wall glass tubing, can vary somewhat in size, cups ranging from 0.9 cm. to 2.5 cm. in diameter having been used successfully. As many as six of the smaller cups, two on each of three plants, have been successfully connected on one recorder, thus giving the average behavior of the three plants. If the edges of the cups are ground, the cement will adhere better than to a smooth surface. The lower ends of the small cups are drawn out enough to permit directly connecting them to small bore rubber tubing. A one-hole stopper containing a piece of glass tubing is inserted in the bottom of the large cups to enable them to be connected to tubing. The volume of the cups and connecting tubing should be kept as small as possible to limit the volume of air in the system, thereby decreasing thermometer effects and increasing the speed of reaction to changes in stomatal aperture.

It is frequently difficult to seal leaves to the leaf cups. Numerous adhesives have been tried with varying success. Anderson found a mixture of approximately 1 part beeswax, 2 parts rosin, 2 parts lanolin and 1 part grafting wax fairly satisfactory for attaching leaf cups to cotton leaves. The writer found that if latex is first exposed to the air until it thickens to the consistency of thick cream it can be used to form a tough, air-tight and non-toxic seal. The edge of the leaf cup is covered with a layer of latex and held in contact with the leaf by means of a light weight until the latex is dry. Leaves of plants growing out-of-doors have been sealed to leaf cups with latex for more than a month without injury. Of course, the leaves must be supported in such a way that movements caused by wind will not

LEAF CLIP

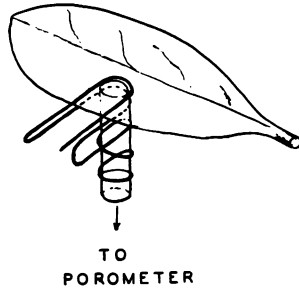

FIG. 2. Leaf clip for fastening leaves to porometer cup.

tear them loose from the rigidly fastened leaf cups. In addition to fastening the branches to supports, it is often helpful to hold the leaf in contact with the cup by means of a wire support as shown in figure 2.

The fulcrum of the magnifying lever was constructed from parts obtained from a cheap alarm clock. The clock was dismantled and all the gears except the balance wheel removed. Wooden dowels whose diameter was equal to the inside diameter of ordinary drinking straws were notched and cemented on opposite sides of the balance wheel similar to two spokes projecting from the same diameter. A straw with a gravity writing point was attached to one of the dowels. A weighted straw was attached to the other dowel to act as a counter balance. A hole was drilled in one of the spokes of the wheel into which could be inserted a free swinging arm which

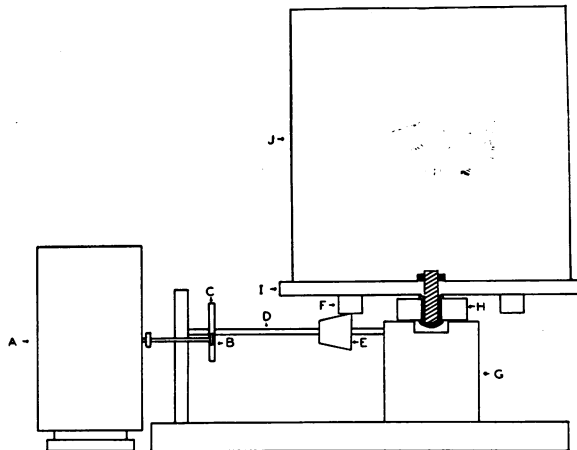

FIG. 3. Diagram showing construction details of kymograph. A, Big Ben clock; B, eight-tooth gear soldered to hour arm; C, forty-eight-tooth gear; D, connecting rod of capillary glass tubing; E, Rubber stopper; F, sponge rubber flange with circumference of four times E; G, kymograph support; H, roller skate bearing; I, kymograph drum platform; J, kymograph drum.

rested on the tambour. Two bolts were soldered to the top of the frame of the clock. The frame was then suspended by means of two screws from a metal L. By adjusting the screws, the writing point of the lever may be set to rest along any portion of the kymograph drum.

The construction of the kymograph is explained in figure 3. Although the construction was simple and very inexpensive, requiring only one ball-bearing roller skate wheel in addition to some gears obtained from the alarm clock, the kymograph was quite accurate and reliable. Eight kymographs were constructed, no one of which varied more than five minutes in twenty-four hours. Regular glazed kymograph paper is most suitable although

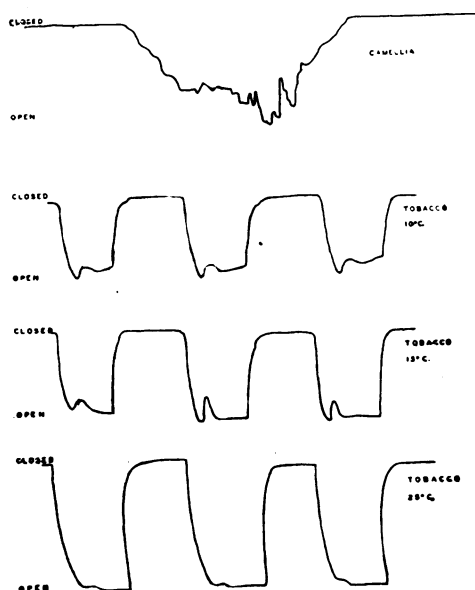

FIG. 4. Tracings of actual records; (a) twenty-four-hour record of *Camellia* under natural conditions; (b) records of tobacco under successive four hour light and dark periods at three different temperatures.

legible records were obtained using paper taken from better grade magazines. The drum, on which has been fastened a sheet of kymograph paper, is smoked over an ordinary wing tip burner whose gas supply has been bubbled through a wash bottle containing benzene. This procedure gives a very smoky flame and is best performed under a hood. After a record has been obtained, the paper is removed from the drum and fixed in a dilute solution of shellac.

Figure 4 shows tracings of actual records obtained from plants growing under both controlled and natural conditions. The results of scores of such records will be published in a later paper.

DEPARTMENT OF BIOLOGICAL SCIENCE
UNIVERSITY OF GEORGIA
ATHENS, GEORGIA

LITERATURE CITED

1. ASHBY, ERIC. Comparison of two methods of measuring stomatal aperture. *Plant Physiol.* **6**: 715-719. 1931.
2. BALLS, W. L. The stomatograph. *Proc. Roy. Soc. B.* **85**: 33-44. 1912.
3. DARWIN, F., and PERTZ, D. F. M. On a new method of estimating the aperture of stomata. *Proc. Roy. Soc. B.* **84**: 136-154. 1912.
4. GREGORY, F. G., and PEARSE, H. L. The resistance porometer and its application to the study of stomatal movement. *Proc. Roy. Soc. B.* **114**: 477-493. 1934.
5. HARTSUIJKER, K. Kritische Bemerkungen über einige der wichtigsten Methoden zur Ermittlung des Öffnungszustandes der Spaltöffnungen. *Rec. Trav. bot. neerland.* **32**: 516-542. 1935.
6. JONES, W. N. A self-recording porometer and potometer. *New Phytol.* **13**: 353-364. 1914.
7. KNIGHT, R. C. A convenient modification of the porometer. *New Phytol.* **14**: 212-216. 1915.
8. ————. On the use of the porometer in stomatal investigations. *Ann. Bot., Lond.* **30**: 57-76. 1916.
9. LAIDLAW, C. G. P., and KNIGHT, R. C. A description of a recording porometer and a note on stomatal behavior during wilting. *Ann. Bot., Lond.* **30**: 47-57. 1916.
10. LOFTFIELD, J. V. G. The behavior of stomata. *Carn. Inst. Washington Pub.* 314. 1921.
11. MASKELL, E. J. The relation between stomatal opening and assimilation—a critical study of assimilation rates and porometer rates in leaves of cherry-laurel. *Proc. Roy. Soc. B.* **102**: 488-533. 1928.
12. NIUS, E. Untersuchungen über den Einfluss des interzellular Volumens und der Öffnungsweite der Stomata auf die Luftwegigkeit der Laubblätter. *Jahrb. wiss. Bot.* **74**: 33. 1931.
13. PAWLENKA, K. Untersuchungen über kurzfristige Einwirkungen von Gasen auf die Luftwegigkeit der Laubblätter. *Beit. Biol. Pfl.* **22**: 273-314. 1934.