

*N*⁶-threonylcarbamoyladenine (*t*⁶A)

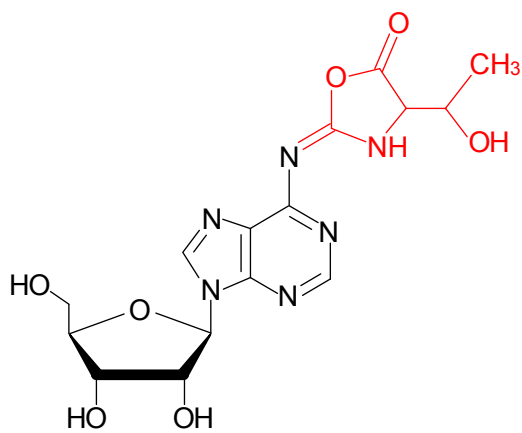

Cyclic-*N*⁶-threonylcarbamoyladenine (*ct*⁶A)

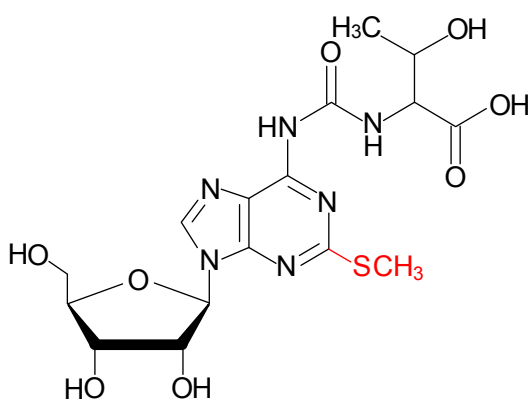

2-methylthio-*N*⁶-threonylcarbamoyladenine (*ms*²*t*⁶A)

Figure S1

A

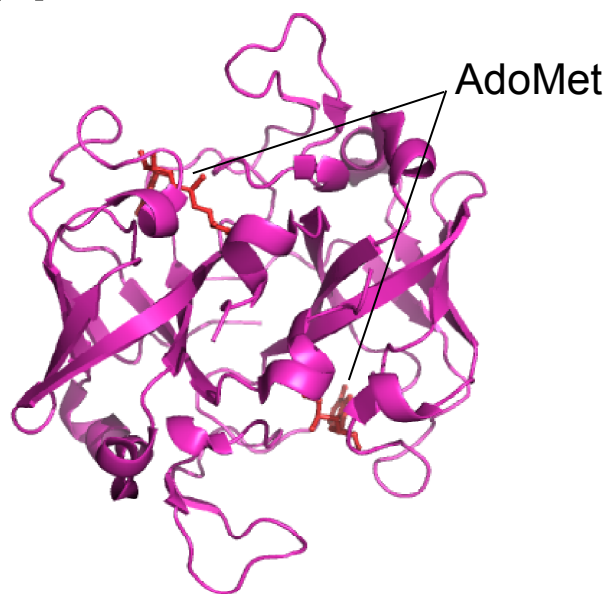

B

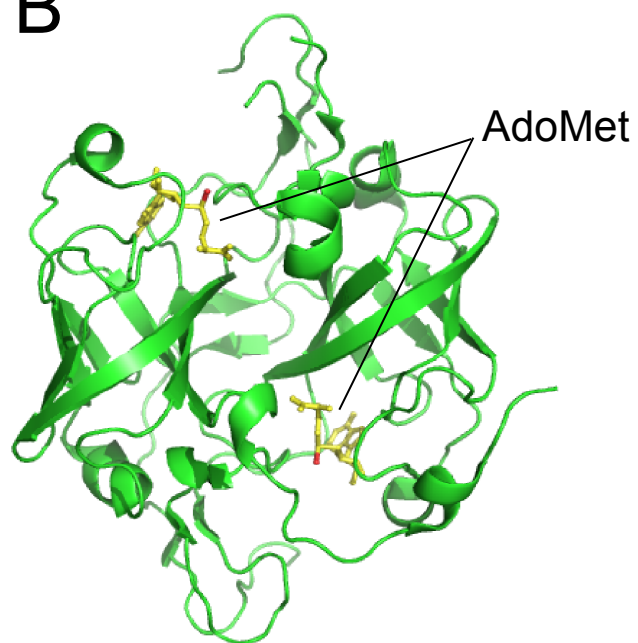

C

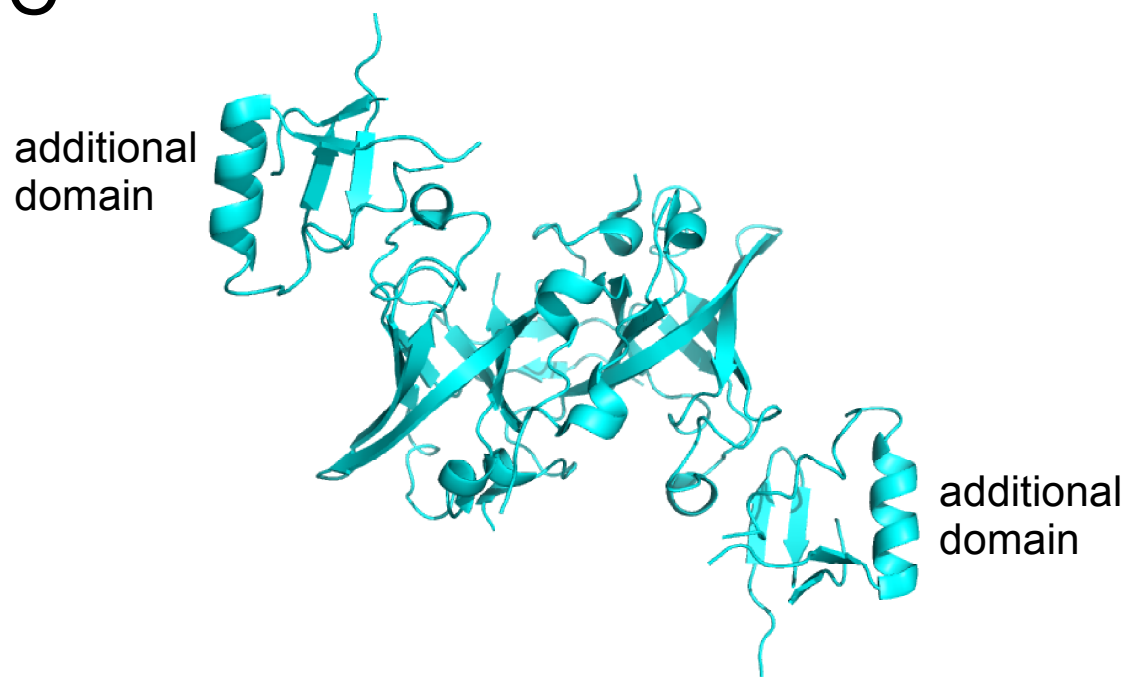

Figure S3

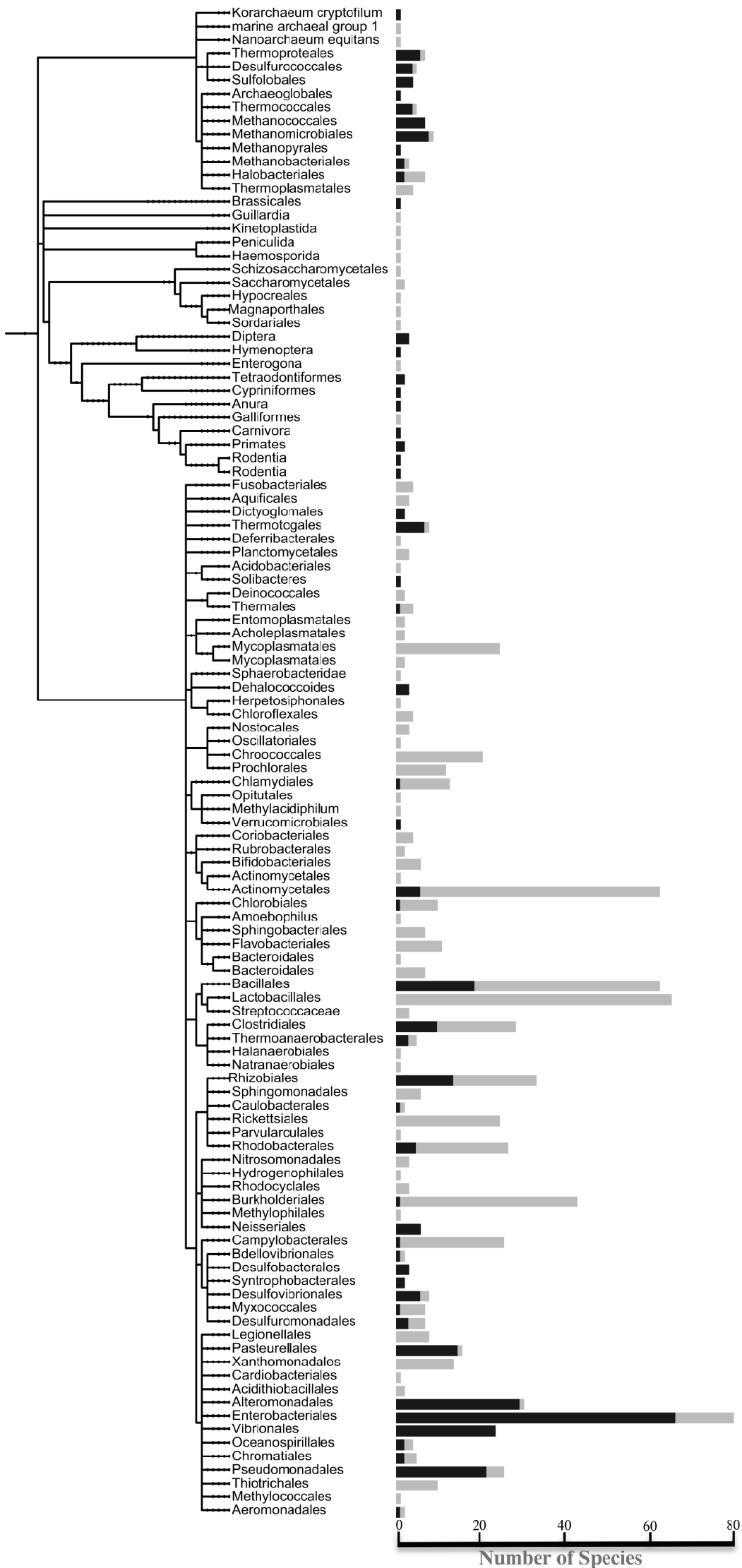

Figure S4

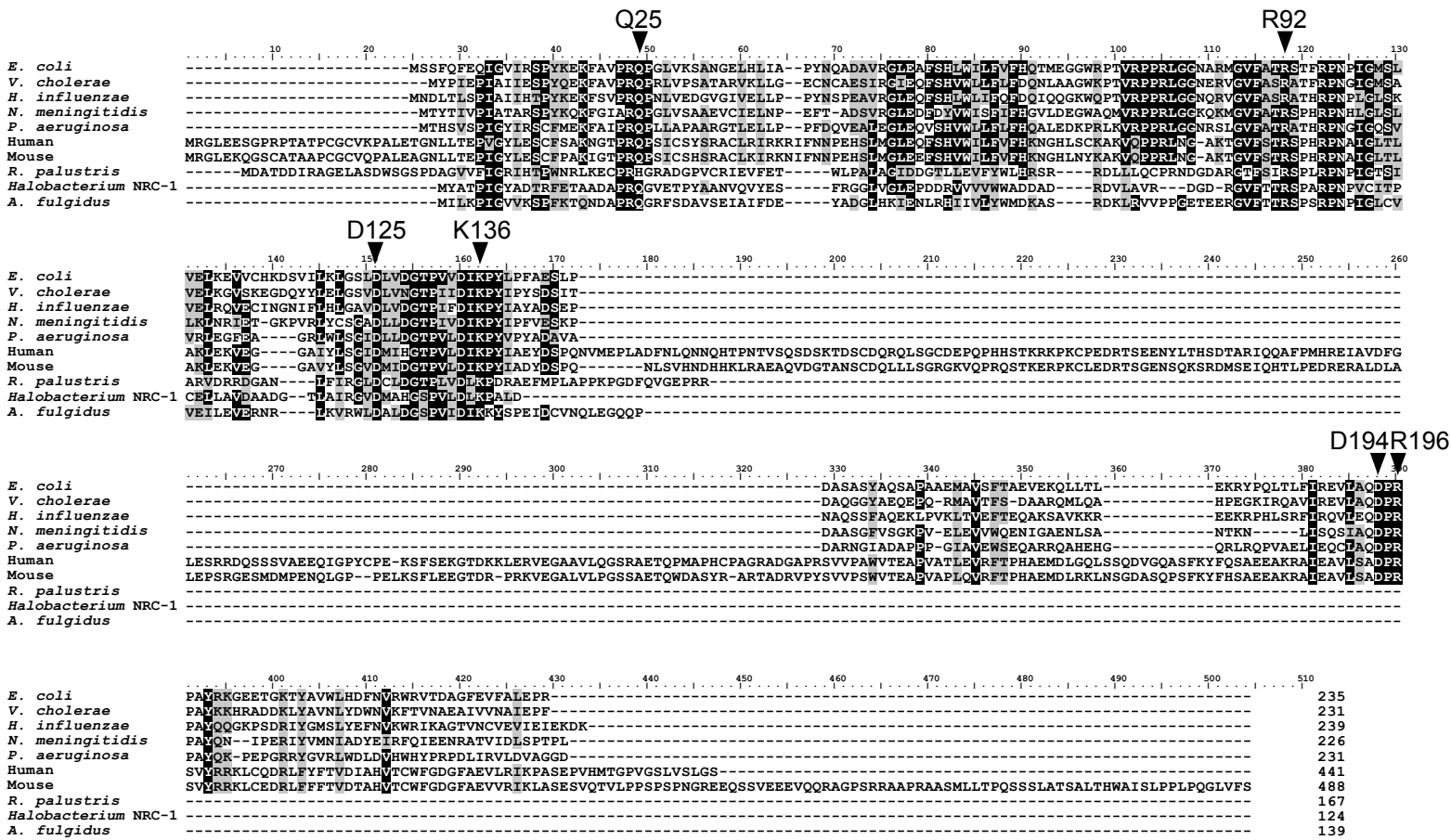
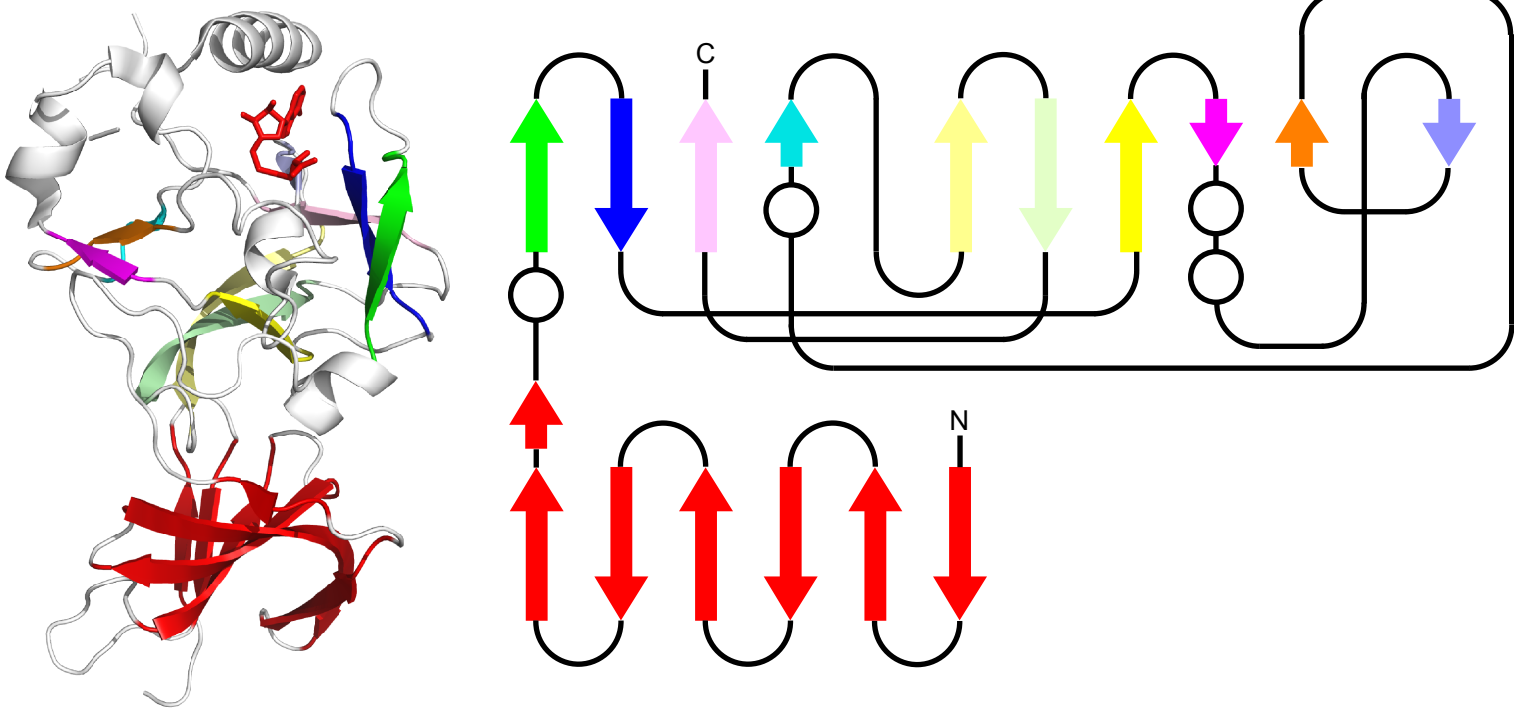

Figure S5

A

Human SETD7



B

A. fulgidus YaeB (AF0241)

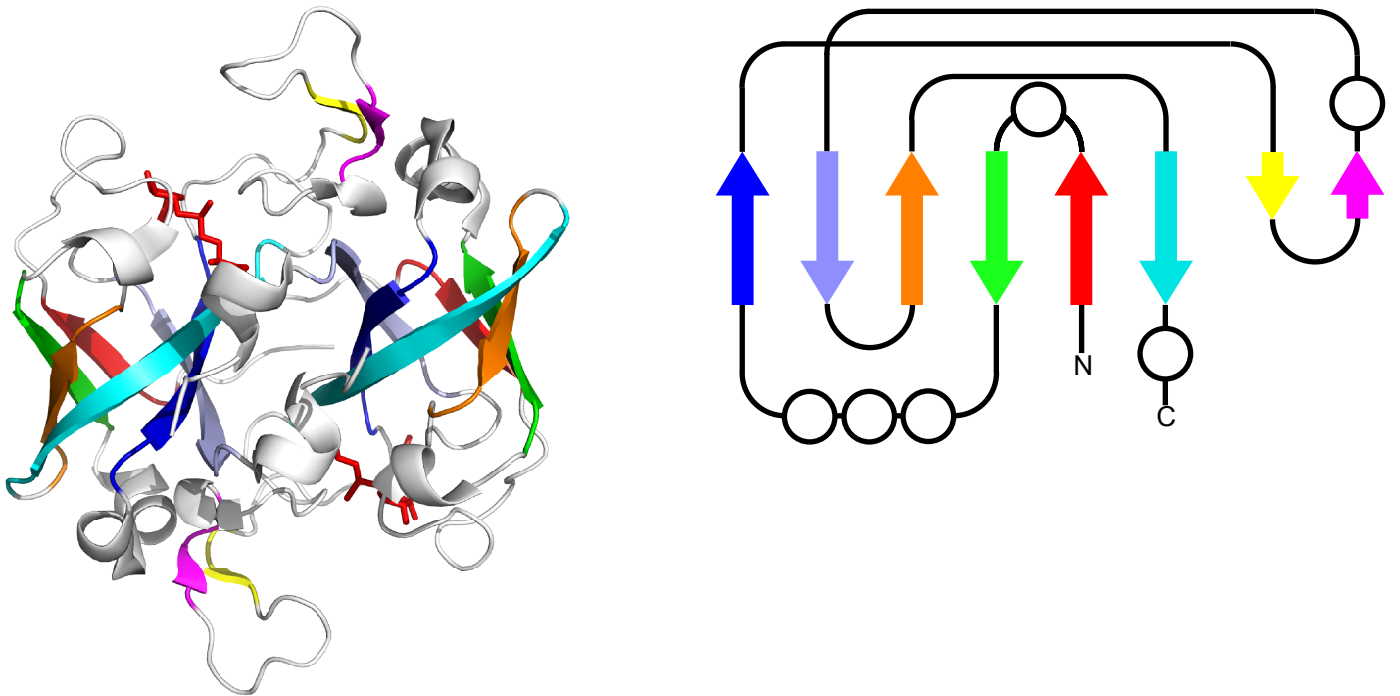

Figure S6

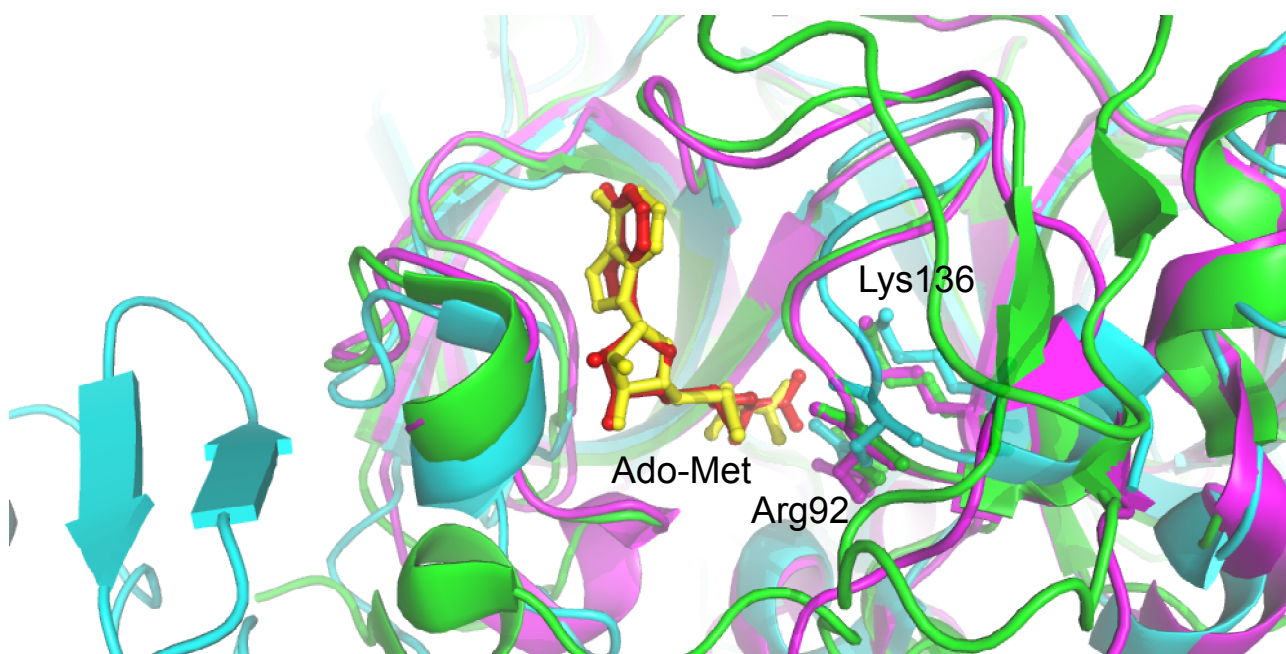

Figure S7

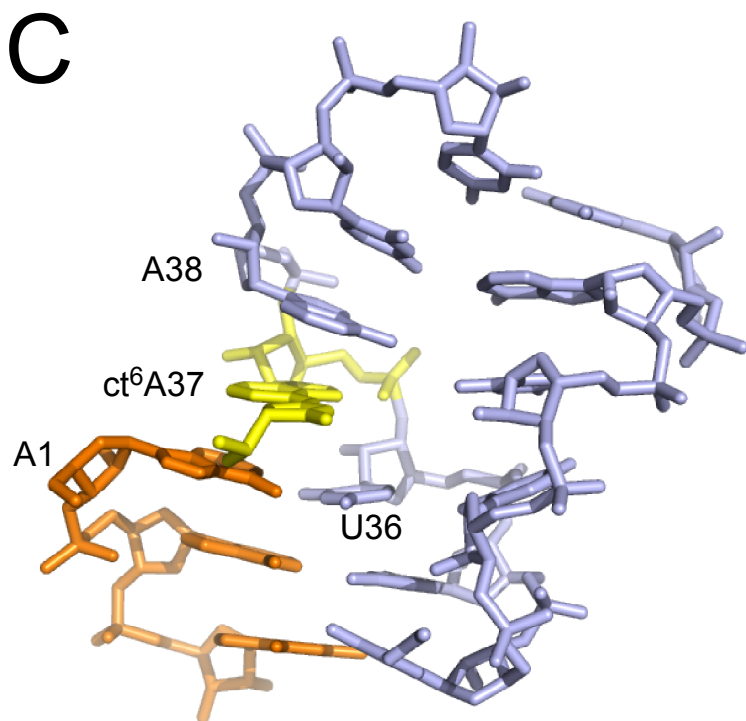
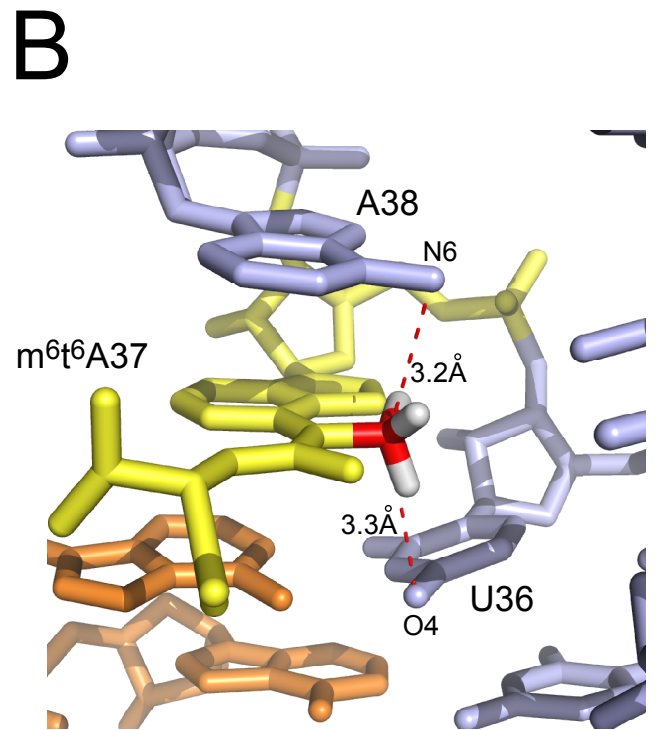
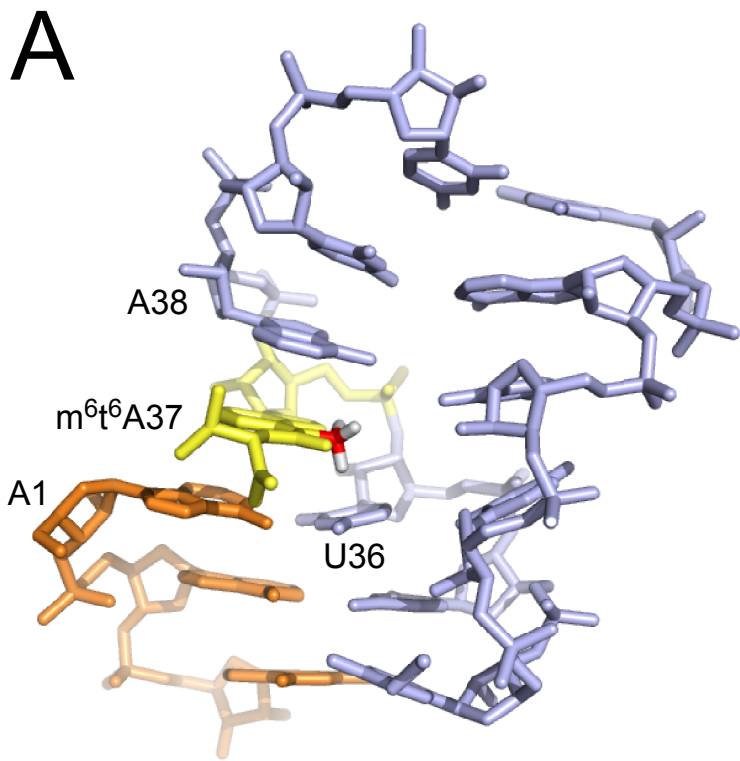

Figure S9