

# Receptor stimulated accumulation of phosphatidylinositol (3,4,5)-trisphosphate by G-protein mediated pathways in human myeloid derived cells

L. Stephens<sup>3</sup>, A. Eguinoa<sup>1</sup>, S. Corey<sup>2</sup>, T. Jackson and P. T. Hawkins

Biochemistry Department, AFRC Institute of Animal Physiology and Genetics Research, Babraham, Cambridge CB2 4AT, UK, <sup>1</sup>Centro de Investigaciones Biológicas (CSIC), C/Velázquez 144 28006 Madrid, Spain and <sup>2</sup>Department of Pediatrics, University of Pittsburgh, 3705 Fifth Street at DeSoto, Pittsburgh, PA 15213, USA

<sup>3</sup>Corresponding author

Communicated by S. Courtneidge

**Phosphoinositide 3OH-kinase (PI3K) activities are thought to be critical regulatory enzymes in a new intracellular signalling pathway, the activation of which results in the rapid accumulation of a putative signalling molecule, phosphatidylinositol (3,4,5)-trisphosphate [PtdIns(3,4,5)P<sub>3</sub>]. To date, activation of PI3K has always correlated with its recruitment into complexes containing protein tyrosine kinases (PTK). Here we report that agonists which utilize G-protein mediated transduction pathways can stimulate very rapid and large accumulations of PtdIns(3,4,5)P<sub>3</sub> via a novel mechanism, possibly involving direct coupling between the G-protein and a PI3K activity. In addition, some of these agonists also stimulate small increases in PI3K activity in anti-phosphotyrosine and anti-*src*-type PTK antibody directed immunoprecipitates, indicating activation of PI3K via a 'conventional' PTK mediated mechanism; these pathways however, play only a minor role in the initial, agonist sensitive production of PtdIns(3,4,5)P<sub>3</sub> in myeloid derived cells.**

**Key words:** G-proteins/neutrophils/p53–p56<sup>lyn</sup>/PI3K/PI3K-kinase/PtdIns(3,4,5)P<sub>3</sub>

## Introduction

A variety of transforming PTKs and also cell surface receptors that use either intrinsic PTKs, *src*-type PTKs or G-proteins to mediate their signals, can activate cellular PI3K activities leading to the accumulation of PtdIns(3,4,5)P<sub>3</sub> and PtdIns(3,4)P<sub>2</sub> (reviewed in Cantley *et al.*, 1991; Downes and Carter, 1991). These two phospholipids are currently believed to represent intracellular signalling molecules but have as yet undefined functions (e.g. Auger *et al.*, 1989).

A PI3K activity that can associate with and be tyrosine phosphorylated by various *src*-type PTKs and/or receptor regulated PTKs has been purified to homogeneity from several mammalian sources: it is a heterodimer with a native molecular mass of 190–200 kDa and comprises a regulatory 85 kDa subunit (p85; Escobedo *et al.*, 1991; Otsu *et al.*, 1991; Skolnik *et al.*, 1991) and a tightly associated 110 kDa catalytic subunit (p110; Carpenter *et al.*, 1990; Shibasaki *et al.*, 1990; Hiles *et al.*, 1992; Ruiz-Larrea *et al.*, 1993). The p85 regulatory subunits harbour two tyrosine phosphate binding domains (SH2 domains, e.g. Koch *et al.*, 1991;

Booker *et al.*, 1992) and also the majority of the tyrosine residues in PI3K that serve as the substrates for various PTKs both *in vivo* and *in vitro* (Gout *et al.*, 1993).

The possession of SH2 domains and a capacity to be tyrosine phosphorylated are common attributes of a family of critical regulatory proteins (like PIC $\gamma$  and *ras*-GAP) that are also translocated into tyrosine phosphate co-ordinated signalling complexes and appear to represent the structural adaptations required for accepting regulation by PTKs (e.g. Schlessinger and Ulrich, 1992). Indeed, recent evidence indicates that PI3K is probably activated directly by the process of binding via its SH2 domains to specific tyrosine phosphate residues which are located in signalling complexes and are the products of receptor stimulated PTKs (Backer *et al.*, 1992; Hu *et al.*, 1992; C.L. Carpenter, K.R. Auger, M. Chaudhuri, B. Schaffhausen, S. Schoelson and L.C. Cantley, submitted). This suggests that the PI3K activities which have currently been purified and 'cloned' are members of a group of proteins that carry unique structural features, which enable them to interact with, and in so doing be activated by, receptor regulated PTKs. As could be expected, these features are not found in proteins that are adapted for receiving inputs from other types of transducing reactions, like G-proteins (Rhee and Choi, 1992).

The possibility that G-protein mediated transduction pathways are implicated in the regulation of PI3K was first suggested by observations, showing that receptors known to couple directly to G-proteins can stimulate accumulation of PtdIns(3,4,5)P<sub>3</sub> (e.g. FMLP and thrombin; Traynor-Kaplan *et al.*, 1989; Kucera and Rittenhouse, 1990; Stephens *et al.*, 1991). This idea was strengthened by studies suggesting that pertussis toxin (an inhibitor of G-protein function) can block FMLP stimulated PtdIns(3,4,5)P<sub>3</sub> accumulation (Traynor-Kaplan *et al.*, 1989; S. Corey, A. Eguinoa, K. Puyana-Theall, J. Bolen, L. Cantley, T. Jackson, P. T. Hawkins and L. Stephens, submitted) and that mastoparan and GTP $\gamma$ S (non-specific activators of G-proteins) can stimulate PtdIns(3,4,5)P<sub>3</sub> accumulation in neutrophils and permeabilized platelets, respectively (Kucera and Rittenhouse, 1990; Norgauer *et al.*, 1992). However, substantial evidence indicates these effects are not directly elicited by the relevant G-proteins but are instead mediated via convoluted G-protein and PTK dependent pathways. Thus, all of the agents thought to activate G-protein dependent accumulation of PtdIns(3,4,5)P<sub>3</sub> have also been shown to stimulate tyrosine phosphorylation of proteins (Nasmith *et al.*, 1989; Huang *et al.*, 1990; King *et al.*, 1991). Furthermore, thrombin has been shown to increase PI3K activity recovered in anti-phosphotyrosine and anti-*src*-type PTK antibody directed immunoprecipitates and to stimulate accumulation of PtdIns(3,4)P<sub>2</sub> via a mechanism that is sensitive to a mixed PTK–protein kinase C (PKC) inhibitor (Gutkind *et al.*, 1990; Yamamoto and Lapetina, 1990). Hence all of these data and the molecular characterization of PI3K are consistent with the notion that

PtdIns(3,4,5)P<sub>3</sub> production can only be regulated by receptors via PTKs. Moreover, the only PTKs currently known to fulfil this role belong to the *src* or receptor PTK families.

## Results and discussion

### Characterization of receptor stimulated

#### PtdIns(3,4,5)P<sub>3</sub> accumulation in human neutrophils and U937 cells

We have attempted to study whether receptor pathways using G-proteins ultimately regulate PI3K activities via PTK co-ordinated mechanisms that are fundamentally similar to those previously described. In order to do this, we have used a variety of G-protein or PTK selective reagents or assays. To check that these reagents or assays had been effective

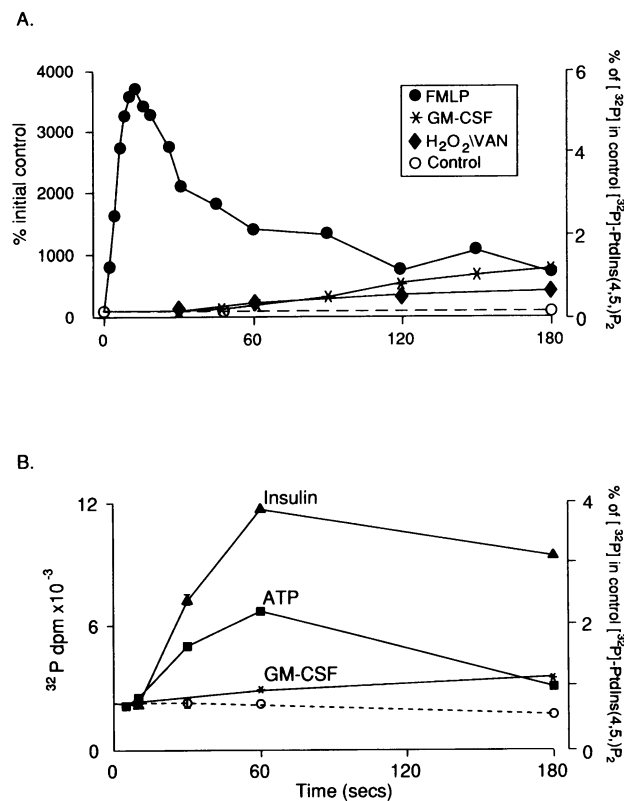

**Fig. 1.** PtdIns(3,4,5)P<sub>3</sub> accumulation in activated neutrophils (A) and U937 cells (B). U937 cells and human neutrophils were labelled with <sup>32</sup>P, washed and then challenged with various stimulants or their vehicle: GM-CSF (100 ng/ml) \*; H<sub>2</sub>O<sub>2</sub>-vanadate (3 and 1 mM, respectively), ◆; FMLP (1 μM), ●; vehicle, ○; insulin (10 μg/ml), ▲; ATP (100 μM), ■. After the indicated times, incubations were quenched and the quantity of [<sup>32</sup>P]PtdIns(3,4,5)P<sub>3</sub> and of the remaining polyphosphoinositides were determined by deacylation and HPLC as described above. The data for the levels of [<sup>32</sup>P]PtdIns(3,4,5)P<sub>3</sub> are presented as means ± SEM or range, (n = 2–8, where the error bars fell within the symbols they were omitted for clarity) of either: the percentage of the initial control level of [<sup>32</sup>P]PtdIns(3,4,5)P<sub>3</sub> (the mean control value was 220 ± 5 d.p.m.), the d.p.m. in PtdIns(3,4,5)P<sub>3</sub>, or as a proportion of control levels of [<sup>32</sup>P]PtdIns(4,5)P<sub>2</sub> (right hand axis, A and B control levels of [<sup>32</sup>P]PtdIns(4,5)P<sub>2</sub> were constant throughout the experimental time frame). Levels of [<sup>32</sup>P]PtdIns(3,4)P<sub>2</sub> rose rapidly in response to all of the stimulants shown above, whilst those of PtdIns3P and PtdIns4P were essentially unchanged (except for PtdIns3P in the presence of H<sub>2</sub>O<sub>2</sub>-vanadate, which increased substantially; see Table I). Levels of [<sup>32</sup>P]PtdIns(4,5)P<sub>2</sub> fell (by a maximum of 40% of control) in response to ATP, H<sub>2</sub>O<sub>2</sub>-vanadate and FMLP (indicating activation of a PIC) but were unchanged by any of the other agonists.

and/or selective, it was necessary to identify individual cell types that were not only appropriately responsive to agonists with G-protein linked receptors, but also to stimuli that use the full range of PTK co-ordinated mechanisms thought to regulate PI3K activities. Two different cell types were eventually chosen for their ability to meet these requirements; human neutrophils and U937 cells (a human, myeloid derived, cell line).

The 'PtdIns(3,4,5)P<sub>3</sub> responses' of neutrophils to FMLP and of U937 cells to ATP (see Figure 1A and B) were both found to be sensitive to pertussis toxin (see Figure 2; and hence probably mediated by Gi<sub>2</sub> and/or Gi<sub>3</sub>; Gierschik

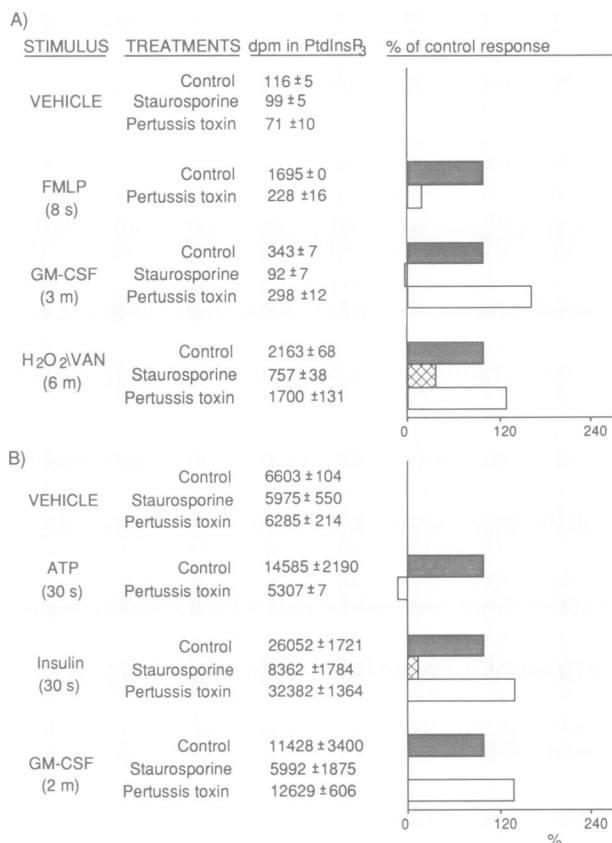

**Fig. 2.** Effects of staurosporine and pertussis toxin on PtdIns(3,4,5)P<sub>3</sub> accumulation in human neutrophils (A) and U937 cells (B). <sup>32</sup>P labelled human neutrophils or U937 cells (either treated with pertussis toxin or control; 88–95% of endogenous Gi-proteins were ADP ribosylated under these conditions, data not shown) were incubated at 37°C with various treatment regimes for a total time of 6 min. Within those 6 min the treatments were: staurosporine (5 μM final concentration) or its solvent alone for 6 min; H<sub>2</sub>O<sub>2</sub>-vanadate (3 and 1 mM, respectively) or vehicle for 6 min; GM-CSF (100 ng/ml) or vehicle (for 2 or 3 min, U937 cells or human neutrophils, respectively); insulin (10 μg/ml), ATP (100 μM) or vehicle for 30 s; FMLP or vehicle for 8 s. Samples were quenched at the end of the stimulation periods defined and [<sup>32</sup>P]PtdIns(3,4,5)P<sub>3</sub> was quantified as described. Data shown are mean d.p.m. ± SEM or range (n = 2–12) in PtdIns(3,4,5)P<sub>3</sub> [\* except in the case of H<sub>2</sub>O<sub>2</sub>-vanadate stimulated neutrophils in which case the data presented are the total <sup>32</sup>P in PtdIns(3,4)P<sub>2</sub> and PtdIns(3,4,5)P<sub>3</sub>]. Those samples stimulated with vehicle for various times were not significantly different and hence were pooled together and presented as a single control. The data are also presented in the form of a histogram showing the response elicited by each stimulant under the different treatment conditions as a percentage of the response to that stimulant in control treated cells (the response in control treated cells was calculated as the increase above vehicle alone). Neither staurosporine nor pertussis toxin treatments significantly altered the unstimulated levels of [<sup>32</sup>P]PtdIns(4,5)P<sub>2</sub> in either U937 cells or human neutrophils (data not shown).

*et al.*, 1991) and became the focal point of these investigations (Traynor-Kaplan *et al.*, 1989; Stephens *et al.*, 1991; Corey *et al.*, submitted). These responses were compared with those elicited by insulin and GM-CSF on U937 cells, and H<sub>2</sub>O<sub>2</sub>-vanadate and GM-CSF on human neutrophils (see Figure 1A and B), agonists or reagents thought to generate their effects via PTK co-ordinated mechanisms: insulin via its receptors intrinsic tyrosine kinase (e.g. Ruderman *et al.* 1990; Schlessinger and Ullrich, 1992), GM-CSF via a *src* type PTK (Corey *et al.*, submitted) and H<sub>2</sub>O<sub>2</sub>-vanadate mixtures by inhibition of protein tyrosine phosphatases (Pumiglia *et al.*, 1992; see below). All of these suspected PTK co-ordinated PtdIns(3,4,5)P<sub>3</sub> responses were found to be insensitive to inhibition by pertussis toxin, but sensitive to the protein kinase inhibitor staurosporine (see Figure 2), confirming expectations that protein kinases may be involved in these receptor pathways.

Although there were substantial differences in the kinetics and intensities of the PtdIns(3,4,5)P<sub>3</sub> responses elicited by this collection of agonists, they were all consistent with the activation of a PtdIns(4,5)P<sub>2</sub> directed PI3K activity (data not shown; Stephens *et al.*, 1991; Hawkins *et al.*, 1992). The only response that diverged from this general pattern was that elicited by H<sub>2</sub>O<sub>2</sub>-vanadate, which stimulated linear accumulations of all three 3-phosphorylated inositol lipids and relatively much larger accumulations of PtdIns(3,4)P<sub>2</sub> and PtdIns3P (Figure 1A and Table I). The reasons for this are unknown, but may be due to the slow cell penetration or mechanism of action of H<sub>2</sub>O<sub>2</sub>-vanadate and/or its effects as a potent inhibitor of a 3-phosphorylated inositol lipid 3-phosphate phosphatase (>90% inhibition of this activity in neutrophil lysates with 250 µM orthovanadate; data not shown).

#### **PI3K activity in anti-Ptyr immunoprecipitates from U937 cells and human neutrophils**

The agonist stimulated appearance of PI3K activity in anti-phosphotyrosine antibody directed immunoprecipitates (anti-Ptyr immunoprecipitates) has proved an accurate marker for stimulation of this system by PTKs (e.g. Auger *et al.*, 1989;

Jackson *et al.*, 1992). FMLP, H<sub>2</sub>O<sub>2</sub>-vanadate mixtures, GM-CSF and insulin all increased the PI3K activity recovered in anti-Ptyr immunoprecipitates from neutrophil and U937 cell lysates (see Figure 3). These effects of FMLP, H<sub>2</sub>O<sub>2</sub>-vanadate mixtures and GM-CSF in neutrophils were abolished by pretreatment with staurosporine, further indicating the likely involvement of PTKs (Figure 3). Thus, these data indicate that in neutrophils or U937 cells, the extent of tyrosine phosphorylation of PI3K, or a tightly associated protein, can be regulated by FMLP, H<sub>2</sub>O<sub>2</sub>-vanadate mixtures, GM-CSF and insulin (in confirmation of previous reports for the latter two agonists; Ruderman *et al.*, 1990; Corey *et al.*, submitted).

#### **FMLP sensitive, G-protein and PTK dependent, regulation of PI3K activity**

The increase in PI3K activity in anti-Ptyr immunoprecipitates caused by FMLP was also specifically abolished by pretreatment with pertussis toxin (in contrast to the response to H<sub>2</sub>O<sub>2</sub>-vanadate mixtures; see Figure 3), suggesting that this response is dependent on a pertussis toxin sensitive G-protein.

A number of agonists (including FMLP) that use G-protein linked receptors have been shown to enhance accumulation of tyrosine phosphorylated proteins, although in none of these cases has the identity of the PTK(s) responsible been established (e.g. Zachary *et al.*, 1991). We screened control and FMLP stimulated neutrophils with a range of antibodies capable of immunoprecipitating non-receptor *src*-type kinases (including p53-p56<sup>lyn</sup>, p62<sup>c-yes</sup>, p56<sup>lck</sup> and p60<sup>src</sup>). We found evidence of an FMLP dependent increase in (i) tyrosine phosphorylation of p53-p56<sup>lyn</sup> and (ii) PI3K activity, specifically in anti-p53-p56<sup>lyn</sup> antibody directed immunoprecipitates (Figure 4 and data not shown). Furthermore, FMLP stimulated 'p53-p56<sup>lyn</sup>-phosphorylation' was sensitive to pertussis toxin (Figure 4). These data suggest that FMLP can activate p53-p56<sup>lyn</sup> via a G-protein mediated pathway and that this activated PTK might, by complexing with a PI3K activity (either directly or indirectly), be responsible for the increase in PI3K activity

**Table I.** 3-phosphorylated lipid metabolism in neutrophils

Treatment	Levels of <sup>32</sup> P labelled lipids			
	PtdIns(4,5)P <sub>2</sub>	PtdIns3P	PtdIns(3,4)P <sub>2</sub>	PtdIns(3,4,5)P <sub>3</sub>
Control	34930 ± 1380	1208 ± 308	126 ± 0	164 ± 2
Vanadate	35273 ± 2350	1505 ± 190	109 ± 15	154 ± 18
Vanadate-H <sub>2</sub> O <sub>2</sub>	24267 ± 1708	2221 ± 20	2083 ± 201	244 ± 17
FMLP	27436 ± 1581	998 ± 152	348 ± 25	1823 ± 59
CB + FMLP	28011 ± 1928	1209 ± 47	409 ± 15	1586 ± 79
GM-CSF	34999 ± 1876	1176 ± 53	523 ± 27	709 ± 25
CB + GM-CSF	34080 ± 2010	1109 ± 8	708 ± 15	840 ± 21
CB	34501 ± 2214	1190 ± 83	149 ± 5	130 ± 15
TPA (90 s)	38905 ± 1642	1841 ± 90	180 ± 8	220 ± 15
TPA (240 s)	32045 ± 1000	2020 ± 181	250 ± 10	191 ± 12
Ro31-7549	33060 ± 2100	1150 ± 201	100 ± 4	155 ± 16
Ro31-7549 + FMLP	25437 ± 2222	1120 ± 125	309 ± 15	1592 ± 83
Ro31-8220	32054 ± 1251	1009 ± 45	98 ± 2	162 ± 5
Ro31-8220 + FMLP	26333 ± 1421	1161 ± 94	298 ± 5	1608 ± 59

<sup>32</sup>P prelabelled human neutrophils were incubated at 37°C for a total time of 10 min, during which time they were treated with: vanadate (1 mM), H<sub>2</sub>O<sub>2</sub>-vanadate (3 and 1 mM, respectively) or vehicle for 8 min; cytochalasin B (CB), Ro31-8220, Ro31-7449 (5, 10 and 10 µM, respectively) or vehicle alone for a total time of 6 min; GM-CSF (100 ng/ml) or vehicle for 3 min; TPA (100 ng/ml) or vehicle alone for 90 or 240 s; and FMLP (1 µM) or vehicle alone for 8 s. Reactions were quenched at the end of the treatment periods defined and the quantity of <sup>32</sup>P labelled phosphoinositides were determined as described. Data shown are mean d.p.m. ± SE or range (n = 2-18). There were no significant differences between the vehicle only controls and hence these data were pooled to supply an overall control.

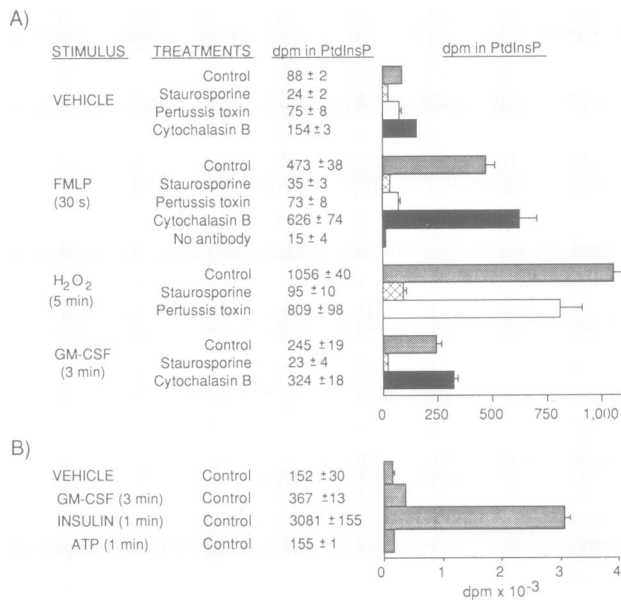
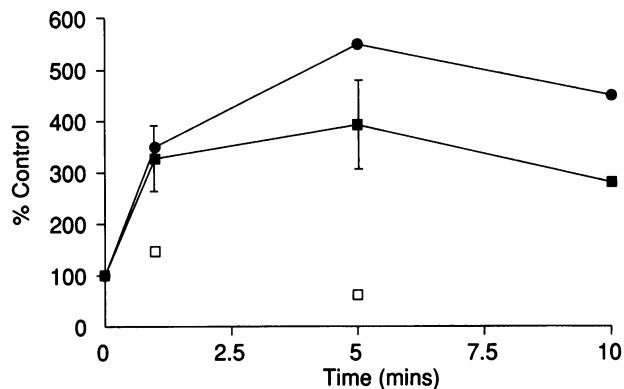

**Fig. 3.** PI3K activities in anti-phosphotyrosine antibody directed immunoprecipitates from neutrophils (A) and U937 cells (B). Human neutrophils (either pertussis toxin pretreated or control) or U937 cells were incubated at 37°C for a total time of 7 min in the presence of either staurosporine (5  $\mu$ M, final concentration), cytochalasin B (5  $\mu$ M) or their solvent alone, during which time they were also stimulated with: H<sub>2</sub>O<sub>2</sub>-vanadate (3 and 1 mM, respectively) or vehicle for 5 min; GM-CSF (100 ng/ml) or vehicle for 3 min; insulin (10  $\mu$ g/ml), MgATP (100  $\mu$ M) or vehicle for 30 s; or FMLP (1  $\mu$ M) or vehicle alone for 8 s. The incubations were quenched at the end of the stimulation periods; lysates were prepared and immunoprecipitated with an anti-phosphotyrosine antibody. PI3K activity in the washed immunoprecipitates was determined and the data are presented as mean d.p.m.  $\pm$  SEM or range ( $n = 2-12$ ) in [<sup>32</sup>P]PtdInsP. Those samples that were treated as controls and stimulated with vehicle alone were not significantly different from one another and hence were pooled.

that can be recovered in anti-Ptyr immunoprecipitates (see above). The mechanism by which *src*-type PTKs such as p53-p56<sup>lyn</sup> could be activated by G-protein dependent mechanisms is unknown. In neutrophils however, FMLP stimulated tyrosine phosphorylation of proteins can be mediated via both calcium and PKC mediated routes (Berkow and Dodson, 1989; Huang *et al.*, 1990).

### PTK independent activation of PtdIns(3,4,5)P<sub>3</sub> accumulation?

Although the pathways suggested by the data above are consistent with previous reports, there are a number of anomalies in the relative sizes of the various responses described and their sensitivities to certain inhibitors. These are most evidently manifest in the failure to observe an ATP stimulated increase in PI3K activity recovered in anti-Ptyr immunoprecipitates from U937 cells (see Figure 3). Thus, although insulin and GM-CSF activated similar, and substantially smaller, accumulations of PtdIns(3,4,5)P<sub>3</sub> respectively, than those produced by ATP (Figure 1), both caused readily detectable increases in phosphotyrosine associated PI3K activity in U937 cell lysates (Figure 3). A variety of similarly apparently anomalous observations suggest that although FMLP can regulate PI3K activities by PTK co-ordinated mechanisms (see above), these PI3K activities may not be responsible for the rapid accumulation

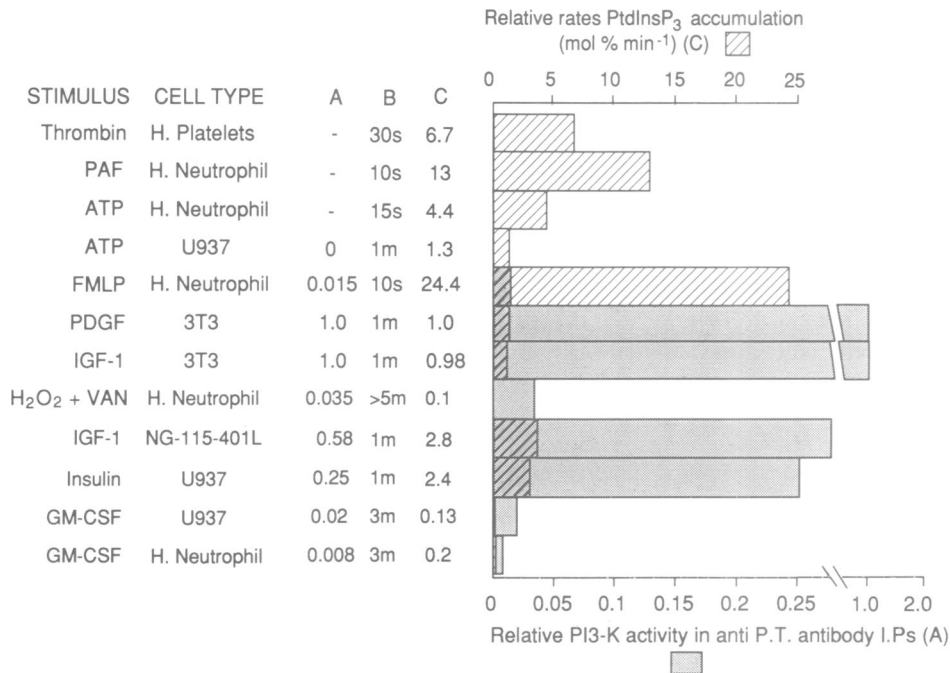

**Fig. 4.** FMLP stimulated increases in PI3K activity and phosphorylation of p53-p56<sup>lyn</sup> in anti-p53-p56<sup>lyn</sup> antibody directed immunoprecipitates. Human neutrophils (either pertussis toxin pretreated,  $\square$  or untreated,  $\bullet$ ,  $\blacksquare$ ) were incubated at 37°C for 10 min in the presence of FMLP (1  $\mu$ M, final concentration,  $\bullet$ ,  $\blacksquare$ ,  $\square$ ) or vehicle alone for 1, 5 or 10 min (pertussis toxin treated cells were not stimulated for 10 min) then lysed and immunoprecipitated with anti-p53-p56<sup>lyn</sup> antibodies. Washed immunoprecipitates were assayed for p53-p56<sup>lyn</sup> phosphorylation ( $\blacksquare$ ,  $\square$ ) and PI3K activity ( $\bullet$ ). Samples challenged with vehicle alone were pooled and plotted as the '0 min controls' for both forms of assay and the pertussis toxin treated and untreated samples. Data are from independent experiments and are presented as the mean  $\pm$  SEM or range ( $n = 2-3$ ) responses to FMLP (as a percentage of control). A paired student's *t* test revealed FMLP had stimulated significant ( $P < 0.02$ ) increases in both PI3K activity and p53-p56<sup>lyn</sup> phosphorylation in neutrophils that had not been treated with pertussis toxin.

of PtdIns(3,4,5)P<sub>3</sub> in FMLP stimulated neutrophils. These anomalies are evident at two levels and these are considered in detail below.

The first level is in the relative intensities with which FMLP activates PtdIns(3,4,5)P<sub>3</sub> accumulation and increases in PI3K activity in anti-Ptyr immunoprecipitates, compared with those of other stimuli effective on the same or different cells. For example, although FMLP can stimulate a PI3K activity responsible for the synthesis of PtdIns(3,4,5)P<sub>3</sub> in intact neutrophils, 120- and 240-fold more intensely than GMCSF and H<sub>2</sub>O<sub>2</sub>-vanadate respectively, it only elicits an  $\sim$ 2-fold greater and a 2-fold smaller increase respectively, in PI3K activity in anti-Ptyr immunoprecipitates (see Figure 5). Similarly, in comparison with agonists that activate PtdIns(3,4,5)P<sub>3</sub> accumulation via receptor PTKs in U937, NG-115-401L, or 3T3 cells, FMLP drives relatively small increases in PI3K activity in anti-Ptyr immunoprecipitates (see Figure 5). Indeed, a recent careful analysis of FMLP stimulated neutrophils failed to detect this response (Vlahos and Matter, 1992).

The second level at which 'anomalies' in the effects of FMLP can be discerned are in the characteristics of the PI3K activity that appears in anti-phosphotyrosine, or anti-*src*-type PTK, antibody directed immunoprecipitates from FMLP stimulated cells, compared with those of the PI3K activity responsible for the rapid accumulation of PtdIns(3,4,5)P<sub>3</sub> in FMLP stimulated neutrophils. These 'anomalies' include the dramatically different time-courses of these responses (compare Figure 1 with Figure 4) and their differential sensitivities to treatment with cytochalasin B (Table I) and staurosporine (Figure 6). The strength of this argument is founded on the observations that the equivalent responses elicited by GM-CSF and H<sub>2</sub>O<sub>2</sub>-vanadate do not appear to display analogous mismatching. Perhaps this is most clearly



**Fig. 5.** Differences in agonist stimulated PI3K activities *in vivo* and *in vitro*. Various cell types were stimulated with the agonists noted and an estimate made of the following. (i) The degree of activation of PtdIns(4,5)P<sub>2</sub> directed PI3K in <sup>32</sup>P labelled intact cells: this is presented as the initial rate of accumulation of [<sup>32</sup>P]PtdInsP<sub>3</sub> expressed as the proportion of [<sup>32</sup>P]PtdIns(4,5)P<sub>2</sub> converted to [<sup>32</sup>P]PtdInsP<sub>3</sub>/min (column C in the Figure, and shown in the histogram, we assumed the monoester phosphates of PtdIns(4,5)P<sub>2</sub> and PtdIns(3,4,5)P<sub>3</sub> had labelled to steady state): the times taken for PtdInsP<sub>3</sub> levels to attain their maximum values for each agonist are shown in column B. (ii) The increase in PI3K activity in anti-PTyr immunoprecipitates ('IPs'): this is presented as the activity recovered/mg lysate protein expressed as a proportion of that found in PDGF stimulated Swiss 3T3 cells [column A and shown in the histogram; cells were stimulated for times that were used to define the rates of PtdIns(3,4,5)P<sub>3</sub> accumulation in (i) above]. The data used are taken from this report, Jackson *et al.* (1992), Poyner *et al.* (1993), Kucera and Rittenhouse (1990), Corey *et al.* (submitted) and L. Stephens (unpublished data), and in each case represent responses elicited by maximally effective doses of the ligands (no data defining the size of this response in thrombin stimulated platelets is currently available). The substantially smaller PI3K signals obtained in anti-PTyr immunoprecipitates from neutrophil lysates did not appear to be due to cell specific 'accessories' (e.g. proteolysis, as mixed 3T3 cell-neutrophil lysates still displayed readily detectable PDGF dependent responses, data not shown) or an inappropriate anti-phosphotyrosine antibody (as several different antibodies gave essentially the same result, data not shown).

evident in the data which suggest that the rapid and intense burst of PtdIns(3,4,5)P<sub>3</sub> accumulation elicited by FMLP is resistant to staurosporine (Figure 6), under conditions that abolished GM-CSF stimulated PtdIns(3,4,5)P<sub>3</sub> accumulation (Figure 2) and both GM-CSF and FMLP stimulated increases in PI3K activity in anti-Ptyr immunoprecipitates (Figure 3). These data indicate that if the FMLP driven 'translocation' of PI3K into anti-Ptyr immunoprecipitates was being manifest as an increase in PtdIns(3,4,5)P<sub>3</sub>, then at least during these early stages of activation, it makes an insignificant (<10%) contribution to the agonist activated accumulation of PtdIns(3,4,5)P<sub>3</sub>. This picture is compatible with evidence that GM-CSF, which stimulates similar increases in PI3K activity in anti-Ptyr and anti-p53-p56<sup>l<sup>yn</sup></sup> immunoprecipitates to those elicited by FMLP, only causes relatively small increases in the rate of accumulation of PtdIns(3,4,5)P<sub>3</sub> (~1% of those of FMLP; see Figure 5 and Corey *et al.*, submitted).

Taking all of the above observations together, they suggest ATP stimulates PtdIns(3,4,5)P<sub>3</sub> accumulation in U937 cells via a G-protein dependent pathway that does not culminate in an increase in PI3K activity in anti-Ptyr immunoprecipitates. Whereas FMLP, although utilizing a similar pathway to generate its primary 'PtdIns(3,4,5)P<sub>3</sub> signal', can also mobilize a second, PTK dependent mechanism which makes only a small contribution to the initial production of PtdIns(3,4,5)P<sub>3</sub>.

#### **Regulation of the PI3K activity responsible for the rapid, large-scale accumulation of PtdIns(3,4,5)P<sub>3</sub> in ATP, or FMLP activated myeloid derived cells**

What is the nature of the G-protein dependent pathway in myeloid derived cells that is regulated by ATP and FMLP, but apparently distinct from the conventional PTK dependent processes in these cells? Precedent suggests that this pathway will be initiated by receptor stimulated dissociation of G<sub>i2</sub> and/or G<sub>i3</sub> into their  $\alpha$  and  $\beta\gamma$  components (Gilman, 1987; Gierschik *et al.*, 1991). The targets of the activated G-protein subunits must include proteins that ultimately trigger the large-scale accumulations of PtdIns(3,4,5)P<sub>3</sub>. In myeloid derived cells, the known targets of Gi proteins include PICs, adenylate cyclases and possibly phospholipase A<sub>2</sub>s and Ds (Axelrod, 1990; Billah *et al.*, 1991; Cockcroft, 1992). Hence, theoretically, any of these effectors, or their downstream effects, could be responsible for coupling to PtdIns(3,4,5)P<sub>3</sub> accumulation. Indeed, we suggest activation of PIC is responsible for coupling the FMLP receptor to a PTK regulated PI3K activity (see above). However, a currently undescribed direct  $\alpha$  or  $\beta-\gamma$  subunit mediated activation of one or more other plausible regulatory mechanisms, e.g. a protein tyrosine phosphatase (Charbonneau *et al.*, 1988), a protein serine kinase (Carpenter *et al.*, 1993) or a PI3K activity itself, could couple G-proteins to the rapid and large-scale accumulation of PtdIns(3,4,5)P<sub>3</sub> (see Figure 7).

**Is G-protein dependent, ATP or FMLP stimulated accumulation of PtdIns(3,4,5)P<sub>3</sub> mediated by known G-protein coupled effector enzymes?**

It is evident from both the restricted number of cells in which receptor activations of a PIC coincide with stimulated accumulation of PtdIns(3,4,5)P<sub>3</sub> (despite the near universal expression of PI3K activities), and the clear examples of agonists that can activate PtdIns(3,4,5)P<sub>3</sub> accumulation without stimulating PICs (e.g. GM-CSF and insulin in myeloid derived cells) that a simple cause-effect relationship between these events does not exist. However, the occurrence of G-protein dependent, large-scale accumulations of

PtdIns(3,4,5)P<sub>3</sub> does presently correlate with activations of PICs. The two primary messages supplied by activation of PICs are increases in intracellular free calcium concentration and activation of PKC. In neutrophils, the increase in PtdIns(3,4,5)P<sub>3</sub> elicited by FMLP is not reduced when intracellular calcium levels are clamped by the use of cell permeant calcium buffers (Traynor-Kaplan *et al.*, 1989) indicating calcium is unlikely to couple this reaction. In platelets, thrombin stimulated accumulation of 3-phosphorylated inositol lipids has been proposed to be dependent on PKC activity (King *et al.*, 1991). However, in neutrophils, the potent PKC stimulant TPA failed to activate PtdIns(3,4,5)P<sub>3</sub> or PtdIns(3,4)P<sub>2</sub> accumulation (see Table I) and indeed abolished or reduced GM-CSF and FMLP stimulated accumulations of this lipid, respectively (Corey *et al.*, submitted). Furthermore, staurosporine and the more selective PKC inhibitors Ro31-8220 and Ro31-7459 (Wakelam *et al.*, 1991), had no effects on FMLP stimulated accumulation of PtdIns(3,4,5)P<sub>3</sub>, under conditions in which they abolished both TPA stimulated reactive oxygen intermediate production in neutrophils and PKC substrate peptide directed protein kinase activity in streptolysin permeabilized neutrophils (see Table 1, data not shown). This evidence, in conjunction with that ruling out a role of calcium mobilization, suggests that in myeloid derived cells it is unlikely that PICs are implicated in the rapid G-protein dependent, receptor stimulated accumulation of PtdIns(3,4,5)P<sub>3</sub> [although these experimental manipulations could be expected to activate or inhibit the FMLP stimulated activation of a PTK regulated PI3K activity, described in Figure 7iii, because this pathway makes such a small contribution to the initial production of PtdIns(3,4,5)P<sub>3</sub> in response to FMLP, even substantial changes in its activity would probably go unnoticed].

Receptors causing dissociation of G<sub>i</sub> family proteins classically inhibit adenylate cyclase (Gilman, 1987). In

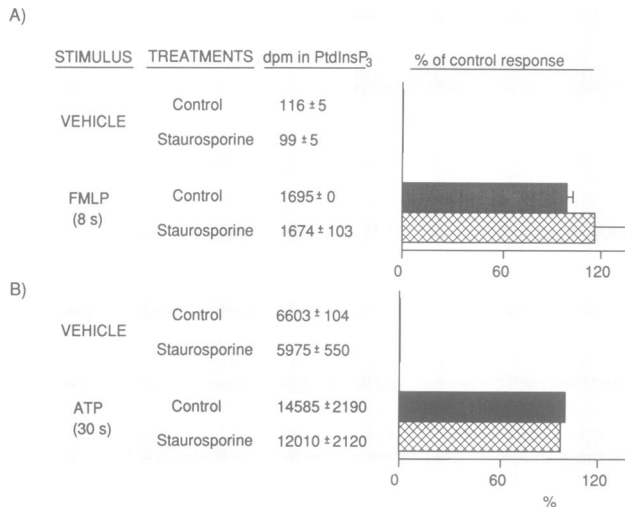

**Fig. 6.** Effects of staurosporine on ATP and FMLP activated PtdIns(3,4,5)P<sub>3</sub> accumulation. <sup>32</sup>P labelled human neutrophils (A) and U937 cells (B) were prepared, treated and stimulated as described in Figure 2. [<sup>32</sup>P]PtdIns(3,4,5)P<sub>3</sub> was quantified and the data are presented as means ± SE or ranges (*n* = 2–4; see Figure 2).

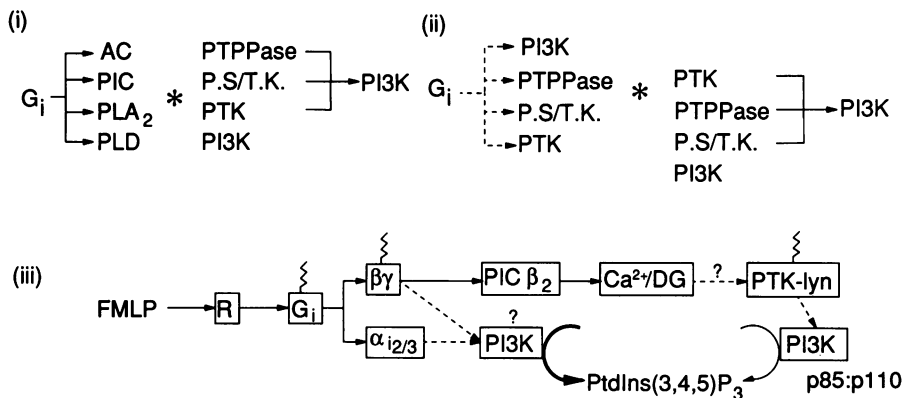

**Fig. 7.** Potential patterns of G-protein dependent signalling in myeloid derived cells. The receptors for ATP, PAF (L. Stephens, unpublished observations) and FMLP elicit pertussis toxin sensitive increases in accumulation of PtdIns(3,4,5)P<sub>3</sub> in myeloid derived cells, probably by directly interacting with an  $\alpha_2$ - or  $\alpha_3$ -containing heterotrimeric G-protein, thereby causing its dissociation and liberation of activated subunits. In myeloid derived cells, liberated subunits from G<sub>i</sub> proteins are known to regulate adenylate cyclase (AC) and PIC (predominantly the PIC $\beta_2$  isoform) and possibly phospholipase A<sub>2</sub> (PLA<sub>2</sub>) and phospholipase D (PLD) activities. These effectors may couple to a PI3K activity directly or via downstream protein tyrosine phosphate phosphatases (PTPPase), protein serine/threonine kinases (P.S/T.K.) or PTKs (see pattern i). Alternatively, PTPP, P.S/T.K., or PTK activities could be postulated to be directly regulated by activated G $\alpha_2$  and/or G $\alpha_3$  subunits and then to directly or indirectly regulate a PI3K activity (see pattern ii). The final suggestion is that PI3K activities may directly interact with G-proteins (one of the possible routes in pattern ii). Panel iii depicts the most plausible configuration for the two pathways by which FMLP appears to stimulate PtdIns(3,4,5)P<sub>3</sub> accumulation in human neutrophils (see text). Activation of the plasma membrane localized FMLP receptor (R) stimulates dissociation of G $\alpha_2$ - and/or G $\alpha_3$ -proteins into  $\beta\gamma$  subunits (containing covalently attached membrane localizing lipid groups) and  $\alpha$  subunits. The released  $\beta\gamma$  components preferentially activate PIC $\beta_2$ , which is abundant in neutrophils, and hence mobilization of calcium and diacylglycerol based signalling systems. This results in activation of the *src*-type PTK p53–p56<sup>lyn</sup> and hence a PTK regulated PI3K activity that makes a small contribution to the initial dramatic increase in PtdIns(3,4,5)P<sub>3</sub> accumulation stimulated by FMLP. However, another G-protein dependent pathway, which does not utilize a PTK based mechanism and that is possibly direct, stimulates an undefined PI3K activity that leads to the large-scale and rapid accumulation of PtdIns(3,4,5)P<sub>3</sub>.

neutrophils, agonists causing activation of adenylate cyclase have no effects on PtdIns(3,4,5)P<sub>3</sub> when acting in isolation and marginally inhibit PI3K activities stimulated by other agonists (Traynor-Kaplan *et al.*, 1989). Hence it is unlikely that inhibition of adenylate cyclase could be responsible for activation of PtdIns(3,4,5)P<sub>3</sub> accumulation. PLA<sub>2</sub> and Ds are universally stimulated by phorbol esters and, in myeloid derived cells, calcium depletion inhibits their activation by agonists (Billah *et al.*, 1991; Cockcroft, 1992), suggesting that neither of these phospholipases are likely to couple G-proteins to PI3K activities.

These data suggest none of the currently recognized G-protein regulated effector enzymes in myeloid derived cells are likely to couple PI3K activities, and hence indicate one of the alternative patterns involving a novel G-protein effector interaction may be implicated (see Figure 7).

#### **A potential role for G-protein regulated protein kinases and/or phosphatases in control of PtdIns(3,4,5)P<sub>2</sub> accumulation?**

Under the conditions used, staurosporine substantially inhibited PtdIns(3,4,5)P<sub>3</sub> accumulation stimulated by GM-CSF, insulin or H<sub>2</sub>O<sub>2</sub>-vanadate, but not that by ATP or FMLP (see above). Furthermore, we have previously shown that genistein (another potent, broadly effective PTK inhibitor; Akiyama *et al.*, 1987; Merida *et al.*, 1992) was able to abolish GM-CSF stimulated PtdIns(3,4,5)P<sub>3</sub> accumulation in neutrophils, but failed to substantially inhibit rapid, FMLP stimulated PtdIns(3,4,5)P<sub>3</sub> accumulation (Corey *et al.*, submitted). These inhibitors have different modes of action (staurosporine is predominantly active at PTKs' ATP binding sites, whereas genistein has a more pronounced impact on the protein binding domains; Akiyama *et al.*, 1987; Fujita-Yamaguchi and Kathuria, 1988) and hence show a degree of complementation in their specificities, which means they inhibit a far broader range of receptor sensitive PTKs than just the families of *src*-type and receptor PTKs currently known to stimulate PI3K activities (e.g. Fujita-Yamaguchi and Kathuria, 1988; Yamamoto and Lapetina, 1990; Chan *et al.*, 1991; Yamashita *et al.*, 1991; Merida *et al.*, 1992; Yatomi *et al.*, 1992; Corey *et al.*, submitted). This suggests that a PTK, which is already known to regulate PI3K activities, is unlikely to operate as a coupling reaction between G-proteins and the PI3K activity responsible for the rapid and large-scale accumulation of PtdIns(3,4,5)P<sub>3</sub> in myeloid derived cells. It remains possible however, that a currently uncharacterized G-protein regulated PTK might control the relevant PI3K activities (the G-protein regulation could be either direct or indirect; see Figure 7). If this is the case, then it must also utilize a quite distinct mechanism of activation, since in contrast to all other situations in which accumulation of PtdIns(3,4,5)P<sub>3</sub> is enhanced, a PI3K activity is not recovered in anti-Ptyr immunoprecipitates. This suggests that the relevant PI3K SH2 domains have not bound to their tyrosine phosphate targets and hence the only mechanism currently known to stimulate PI3K activity cannot be responsible for enhanced PtdIns(3,4,5)P<sub>3</sub> accumulation in these situations. It also remains possible that a novel PI3K directed phosphotyrosine phosphatase is responsible for coupling the actions of FMLP or ATP to PtdIns(3,4,5)P<sub>3</sub> accumulation. This would, however, require the PTK responsible for phosphorylating the regulatory tyrosine

residues to be relatively inactive in unstimulated cells and/or resistant to staurosporine and genistein. Similarly, a putative receptor/G-protein sensitive PI3K directed protein serine and/or threonine kinase activity could mediate this regulation (possibly the protein kinase activity found tightly associated with PI3Ks purified from rat liver; Carpenter *et al.*, 1993). Although this notion is supported by the presence of serine phosphate residues on purified PI3Ks (Carpenter *et al.*, 1990), it would again demand the existence of a novel regulatory mechanism.

#### **General discussion**

The most simple explanation for the data presented is that a PI3K activity can be directly regulated by a G-protein and that this activity is responsible for the rapid accumulation of PtdIns(3,4,5)P<sub>3</sub> in FMLP or ATP stimulated myeloid derived cells. This suggests G-protein linked receptors are able to activate PtdIns(3,4,5)P<sub>3</sub> accumulation by two independent mechanisms (see Figure 7iii). One of these is indirect, although because it appears to depend on PICs, *src*-type PTKs and an apparently 'conventional' PTK regulated PI3K activity, all of which are expressed in many cells, it may be widely distributed. Used in the context that it is by FMLP, this mechanism may serve to enable G-protein linked receptors to utilize a 'PtdIns(3,4,5)P<sub>3</sub> response' in a role more akin to those it plays in the actions of growth factors and cytokines. However, in platelets, which appear to be a situation in which the apparent hyperexpression of *src*-type PTKs (Perlmutter *et al.*, 1988) is associated with extensive use of these types of G-protein regulated PTK activities, this form of pathway may become the major mechanism by which an agonist like thrombin can regulate PI3K activities. The other mechanism is more clearly distinct from those previously described and may depend on direct interaction between a PI3K activity and activated G-protein subunits.

PICs are the only class of signalling enzyme currently known to interact with both G-proteins and receptor regulated PTKs and separate families of isoforms ( $\beta$  and  $\gamma$ , respectively) are structurally adapted for regulation by these transduction proteins (Rhee and Choi, 1992). Receptor stimulation of PIC $\beta$ s typically result in larger and more rapid accumulations of InsP<sub>3</sub> than those elicited via activation of PIC $\gamma$ s. Hence this offers an explanation of the speed and scale with which FMLP, PAF and ATP can activate PtdIns(3,4,5)P<sub>3</sub> accumulation in neutrophils (see Figure 5). Whether this analogy with receptor regulation of PICs extends to include distinct G-protein regulated forms of PI3K activity is not yet clear. The currently defined forms of PI3K activities all carry the SH2 domain and tyrosine phosphate residues that are trademarks of adaption for regulation by PTKs (see Introduction). There is no fundamental reason, however, why one (defined by the presence of the appropriate p85 subunit?) or all of these PI3Ks could not receive and transduce G-protein inputs. One possible point of interaction between PI3K and GTP binding proteins is a region of homology in p85 with the product of the breakpoint cluster region gene BCR, *N*-chimaerin and rho GAP (termed the BCR region; Otsu *et al.*, 1991). This BCR region confers GTPase activating activity for specific *ras* related small molecular weight G-proteins and this, together with a documented association between PI3K and *ras* (Sjölander *et al.*, 1991), prompted the suggestion that PI3K

may be under the control of small G-proteins (Fry, 1992). However, the insensitivity of small G-proteins to inhibition by pertussis toxin suggests that if they are directly involved in the coupling of FMLP and ATP receptors to PtdInsP<sub>3</sub> production then they must function downstream of a classical heterotrimeric G-protein.

The situations in which apparently direct, receptor regulated, G-protein mediated accumulation of PtdIns(3,4,5)P<sub>3</sub> occur are currently limited to a closely related group of cells, including neutrophils, U937 cells, HL60 cells (L. Stephens, unpublished observations) and platelets (see above). However, the receptors, the Gi<sub>2</sub> and Gi<sub>3</sub> proteins apparently implicated in these processes, and the currently characterized PTK regulated forms of PI3K activity, are relatively widely distributed (Carpenter and Cantley, 1990; Kaziro *et al.*, 1991). Furthermore, GTPγS stimulated dissociation of Gi<sub>2</sub> and Gi<sub>3</sub> proteins in permeabilized 3T3 cells failed to activate PtdIns(3,4,5)P<sub>3</sub> accumulation, despite the presence of PI3K activity in these cells (Jackson *et al.*, 1992). These results are most easily explained by cell specific expression of a G-protein sensitive form of PI3K activity. However, the possibility that the βγ subunits of Gi are implicated in effector activations (Camps *et al.*, 1992), means this cell specificity could be dictated by tissue specific variation in the βγ subunits in Gi proteins. Whatever the mechanisms are that underlie the receptor and/or cell specific expression of the capacity to regulate PI3K activities via G-proteins, they evidently extend the potential kinetic scope of a putative PtdIns(3,4,5)P<sub>3</sub> signal and therefore its biological utility. Hence these mechanisms serve to endow certain agonists with the ability to stimulate the largest and most rapid accumulations of PtdIns(3,4,5)P<sub>3</sub> specifically in cells like neutrophils and platelets. Perhaps this indicates that the processes that regulate the major changes in cytoskeletal structure and cell adhesion or shape, which are such prominent features of neutrophil and platelet activation, are potential targets of a PtdIns(3,4,5)P<sub>3</sub> signal.

## Materials and methods

### Materials

Materials were from sources that we have defined previously (Stephens *et al.*, 1991; Jackson *et al.*, 1992; Corey *et al.*, submitted). H<sub>2</sub>O<sub>2</sub>-vanadate solutions were prepared at room temperature 5 min before use. Ro31-7549 and Ro31-8220 were generously supplied by T.J. Hallam (Roche, Herts, UK).

### Preparation of cells, <sup>32</sup>P labelling, pertussis toxin treatment, quenching reactions, extraction and resolution of lipids

Human neutrophils were freshly isolated and resuspended in a HEPES buffered balanced salts solution with 0.2% w/v, fatty acid free BSA as described previously by Stephens *et al.* (1991). Neutrophils were labelled with <sup>32</sup>Pi (2 mCi/ml for 70 min at 4 × 10<sup>7</sup> cells/ml); and/or treated with pertussis toxin (1.5 μg/ml for 2.5 h at 2 × 10<sup>7</sup> cells/ml) as described previously by Stephens *et al.* (1991) and Corey *et al.* (submitted). U937 cells were cultured in RPMI 1640, 5% heat inactivated fetal calf serum and serum starved (16 h in RPMI, 0.1% w/v, fatty acid free BSA) prior to use. U937 cells were pertussis toxin treated (500 ng/ml, for the last 5 h of the serum starvation) and/or labelled with <sup>32</sup>Pi (0.3 mCi/ml for 70 min at 2.5 × 10<sup>7</sup> cells/ml), as detailed in Corey *et al.* (submitted). After labelling, neutrophils and U937 cells were washed three times in their relevant balanced salts solutions and resuspended in these solutions supplemented with 0.5% w/v, fatty acid free BSA, at 4 × 10<sup>7</sup> or 2.5 × 10<sup>7</sup> cells/ml, respectively. Aliquots (150 μl) of <sup>32</sup>P labelled neutrophils or U937 cells were transferred to glass tubes (Micro cap, 5 ml, Cam Lab) at 37°C. After addition of agonist- or drug-containing solutions, incubations typically contained a final aqueous volume of 180 μl. Incubations were quenched by mixing them with 750 μl of chloroform-methanol-H<sub>2</sub>O (32.6%:65.3%:2.1%, v/v/v) to produce a homogenous primary extraction

phase (Bligh and Dyer, 1959). Phases were separated with chloroform [725 μl; containing (i) 8000 d.p.m. of [<sup>3</sup>H]PtdIns(4,5)P<sub>2</sub> to act as an internal chromatographic marker and an indicator of recovery through the extraction processes and (ii) 'Folch' lipids, 10 μg phosphorus per sample, to act as a carrier] and 2.4 M HCl, 5 mM tetrabutylammonium sulphate (172 μl) to yield a stable two phase solvent system (Folch *et al.*, 1957). Lipids were extracted from the lower phase as described previously by Jackson *et al.* (1992) and Corey *et al.* (submitted). The resulting dry lipid film was either deacylated directly with mono-methylamine reagent (Clarke and Dawson, 1981; 200 μl of reagent, prepared from methylamine gas, was added and incubated at 53°C for 30 min) then processed as described by Stephens *et al.* (1991) and Corey *et al.* (submitted) or dissolved in chloroform-methanol (2:1; v/v), applied to a TLC plate and resolved as described by Jackson *et al.* (1992) and Corey *et al.* (submitted). The water soluble head groups from deacylated lipids were resolved by anion exchange HPLC (Stephens *et al.*, 1991; Corey *et al.*, submitted).

### Preparation of cell lysates and immunoprecipitation protocols

Human neutrophils and U937 cells were resuspended in their relevant balanced salts solutions supplemented with 1 mM orthovanadate (2 × 10<sup>7</sup> and 1.4 × 10<sup>7</sup> cells/ml, respectively; Stephens *et al.*, 1991; Corey *et al.*, submitted) treated with di-isopropylfluorophosphate (1 mM for 5 min at room temperature) then incubated with various inhibitors or stimulants at 37°C, as defined in the figures. Reactions were terminated by rapid centrifugation in a microfuge, removal of the medium and addition of ice-cold lysis buffer (1.0 ml, Corey *et al.*, submitted) to yield lysates with final cell derived protein concentrations of 1 mg/ml for U937 cells and 0.5–0.6 mg/ml for neutrophils. After 10 min on ice, lysates were cleared by centrifugation (4000 g for 30 min at 0°C) and aliquots of the supernatant were removed for immunoprecipitation protocols.

Anti-phosphotyrosine antibody directed immunoprecipitates were prepared and assayed for PI3K activity, precisely as described previously (monoclonal antibody PY20 was from ICN and routinely 8 μl were added to 800 μl of lysate; Corey *et al.*, submitted). Similarly, anti-src-type PTK antibody directed immunoprecipitates were prepared using antiserum directed against a number of src related PTKs (4 μg into 1 ml of lysate: Bolen *et al.*, 1991) as described previously (Corey *et al.*, submitted). The washed immune precipitates were then assayed for either PI3K activity (as described in Auger *et al.*, 1989) or p53-p56<sup>lyn</sup> targeted protein kinase activity [phosphoamino acid analyses confirmed that the <sup>32</sup>P was only found in phosphotyrosine residues; methods as described in Corey *et al.* (submitted)]. The PI3K assays were quenched and the [<sup>32</sup>P]lipid products extracted and resolved by TLC or deacylated and resolved by HPLC (in the presence of internal [<sup>3</sup>H]GroPIns3P and [<sup>3</sup>H]GroPIns4P; Corey *et al.*, submitted); the latter technique showed the major [<sup>32</sup>P]lipid detected in these assays was [<sup>32</sup>P]PtdIns3P.

## Acknowledgements

L.S. is grateful to Amersham Intl Plc for a research grant and to R.F. Irvine and his department for helpful discussions (and blood). A.E. was in receipt of an EMBO short term fellowship. S.C. is funded by NIHK11-HLO2303. PTH and TJ are Lister and Royal Society research fellows, respectively.

## References

- Akiyama, T., Ichida, J., Nakagawa, S., Oganara, H., Watanabe, S., Itah, N., Shibuya, M. and Fukami, Y. (1987) *J. Biol. Chem.*, **262**, 5592–5595.
- Auger, K.R., Serunian, L.A., Soltoff, S., Libby, P. and Cantley, L.C. (1989) *Cell*, **57**, 167–175.
- Axelrod, J. (1990) *Biochem. Soc. Trans.*, **18**, 503–507.
- Backer, J.M. *et al.* (1992) *EMBO J.*, **11**, 2469–2479.
- Berkow, R.L. and Dodson, R.W. (1990) *Blood*, **75**, 2445–2452.
- Billah, M.M., Anthes, J.C. and Mullmann, T.J. (1991) *Biochem. Soc. Trans.*, **19**, 324–329.
- Bligh, E.G. and Dyer, U.J. (1959) *Can. J. Biochem. Physiol.*, **37**, 911–917.
- Bolen, J.B., Thompson, P.A., Eiseman, E. and Horak, R. (1991) *Adv. Cancer Res.*, **57**, 103–149.
- Booker, G.W., Breeze, A.L., Downing, A.K., Panayotou, G., Gout, I., Waterfield, M.D. and Campbell, I.D. (1992) *Nature*, **358**, 684–687.
- Camps, M., Hou, C., Sidiropoulos, D., Stock, J.B., Jakobs, K.H. and Gierschik, P. (1992) *Eur. J. Biochem.*, **206**, 821–831.
- Cantley, L.C., Auger, K.R., Carpenter, C., Duckworth, B., Graziani, A., Kapeller, R. and Soltoff, S. (1991) *Cell*, **64**, 281–302.
- Carpenter, C.L. and Cantley, L. (1990) *Biochemistry*, **29**, 11148–11156.
- Carpenter, C.L., Duckworth, B.C., Auger, K.R., Cohen, B.,



- Schaffhausen, B.S. and Cantley, L.C. (1990) *J. Biol. Chem.*, **265**, 19704–19711.
- Carpenter, C.L., Auger, K.R., Duckworth, B.C., Hou, W.-H. and Cantley, L.C. (1993) *Mol. Cell. Biol.*, **13**, 1657–1665.
- Chan, A.C., Irving, B.A., Fraser, J.D. and Weiss, A. (1991) *Proc. Natl Acad. Sci. USA*, **88**, 9166–9170.
- Charbonneau, H., Tonks, N.K., Walsh, K.A. and Fisher, E.H. (1988) *Proc. Natl Acad. Sci. USA*, **85**, 7182–7186.
- Clarke, N.G. and Dawson, R.M.C. (1981) *Biochem. J.*, **195**, 301–306.
- Cockcroft, S. (1992) *Biochim. Biophys. Acta*, **1113**, 135–160.
- Downes, C.P. and Carter, N.G. (1991) *Cell Signalling*, **3**, 501–513.
- Escobedo, J.A., Navakasattusas, S., Kavanaugh, W.M., Milfay, D., Fried, V.A. and Williams, L.T. (1991) *Cell*, **65**, 75–82.
- Folch, J., Lees, M. and Stanley, G.H. (1957) *J. Biol. Chem.*, **226**, 497–509.
- Fry, M.J. (1992) *Curr. Biol.*, **2**, 78–80.
- Fujita-Yamaguchi, Y. and Kathuria, S. (1988) *Biochem. Biophys. Res. Commun.*, **157**, 962–966.
- Gierschik, P., Sidiropoulos, D. and Jakobs, K.H. (1989) *J. Biol. Chem.*, **264**, 21470–21473.
- Gierschik, P., Moghtader, R., Straub, C., Diterich, K. and Jakobs, K.H. (1991) *Eur. J. Biochem.*, **197**, 725–732.
- Gilman, A.G. (1987) *Annu. Rev. Biochem.*, **56**, 615–649.
- Gout, I., Dhand, R., Panayaton, G., Fry, M.J., Hiles, I., Otsu, M. and Waterfield, M.D. (1993) *Biochem. J.*, **288**, 395–405.
- Gutkind, J.S., Lacal, P.M. and Robbins, K.C. (1990) *Mol. Cell. Biol.*, **10**, 3806–3809.
- Hawkins, P.T., Jackson, T.R. and Stephens, L.R. (1992) *Nature*, **358**, 157–159.
- Hiles, I.D. *et al.* (1992) *Cell*, **70**, 419–430.
- Hu, P., Margolis, B., Skolnik, E.Y., Ulrich, A. and Schlessinger, J. (1992) *Mol. Cell. Biol.*, **12**, 981–990.
- Huang, C.-K., Bonak, V., Laramée, G.R. and Casnelli, J.E. (1990) *Biochem. J.*, **269**, 431–436.
- Jackson, T., Stephens, L. and Hawkins, P.T. (1992) *J. Biol. Chem.*, **267**, 16627–16636.
- Kaziro, Y., Itoh, H., Kozasa, T., Nakafuku, M. and Satoh, T. (1991) *Annu. Rev. Biochem.*, **60**, 349–400.
- King, W.G., Kucera, G.L., Sorisky, A., Zhang, J. and Rittenhouse, S.E. (1991) *Biochem. J.*, **278**, 475–480.
- Koch, C.A., Anderson, D., Moram, M., Ellis, C. and Pawson, J. (1991) *Science*, **252**, 668–674.
- Kucera, G.L. and Rittenhouse, S.E. (1990) *J. Biol. Chem.*, **265**, 5345–5348.
- Merida, I., Diez, E. and Gaulton, G. (1992) *J. Cell. Biochem. Keystone Suppl.* **16B**, p. 198.
- Nasmith, P.E., Mills, G.B. and Grinstein, S. (1989) *Biochem. J.*, **257**, 893–897.
- Norgauer, J., Eberle, M., Lemke, H.D. and Aktories, K. (1992) *Biochem. J.*, **282**, 393–397.
- Otsu, M. *et al.* (1991) *Cell*, **65**, 91–104.
- Perlmutter, R.M., Marth, J.D., Ziegler, S.F., Garvin, A.M., Pawar, S., Cooke, M.P. and Abraham, K.M. (1988) *Biochim. Biophys. Acta*, **948**, 245–262.
- Poyner, D.R., Hanley, M.R., Jackson, T.R. and Hawkins, P.T. (1993) *Biochem. J.*, **290**, 901–905.
- Pumiglia, K.M., Lau, L.F., Huang, C.-K., Burroughs, S. and Feinstein, M.B. (1992) *Biochem. J.*, **288**, 441–449.
- Rhee, S.G. and Choi, K.D. (1992) *J. Biol. Chem.*, **267**, 12393–12396.
- Ruderman, N.B., Kapeller, R., White, M.F. and Cantley, L.C. (1990) *Proc. Natl Acad. Sci. USA*, **87**, 1411–1415.
- Ruiz-Larrea, F. *et al.* (1993) *Biochem. J.*, **290**, 609–616.
- Schlessinger, J. and Ullrich, A. (1992) *Neuron*, **9**, 383–391.
- Shibasaki, F., Homma, Y. and Takenawa, T. (1990) *J. Biol. Chem.*, **266**, 8108–8114.
- Sjölander, A., Yamamoto, K., Huber, B.E. and Lapetina, E.G. (1991) *Proc. Natl Acad. Sci. USA*, **88**, 7908–7912.
- Skolnik, E.Y., Margolis, B., Mohammad, M., Lowenstein, E., Discher, R., Drepps, A., Ullrich, A. and Schlessinger, J. (1991) *Cell*, **65**, 83–90.
- Stephens, L.R., Hughes, K.T. and Irvine, R.F. (1991) *Nature*, **357**, 33–39.
- Traynor-Kaplan, A.E., Thompson, B.L., Harris, A.L., Taylor, P., Omann, G.M. and Sklar, L.A. (1989) *J. Biol. Chem.*, **264**, 15668–15673.
- Vlahos, C.J. and Matter, W.F. (1992) *FEBS Lett.*, **309**, 242–248.
- Wakelam, M.J.O., Cook, S.J., Currie, S.J., Palmer, S. and Plevin, R. (1991) *Biochem. Soc. Trans.*, **19**, 321–324.
- Yamamoto, K. and Lapetina, E.G. (1990) *Biochem. Biophys. Res. Commun.*, **168**, 466–472.
- Yamashita, Y., Hasegawa-Sasaki, H. and Sasaki, T. (1991) *FEBS Lett.*, **288**, 46–50.
- Yatomi, Y., Dzaki, Y. and Kume, S. (1992) *Biochem. Biophys. Res. Commun.*, **186**, 1480–1486.
- Zachary, I., Gil, J., Lehmann, W., Sinnett-Smith, J. and Rozengurt, E. (1991) *Proc. Natl Acad. Sci. USA*, **88**, 4577–4581.

Received on November 27, 1992; revised on March 2, 1993

## Note added in proof

Corey *et al.* (submitted) has now been accepted for publication in *EMBO J.*, Vol. 12, No. 7, 1993.