

**Optogenetic control of *Drosophila* using a red-shifted channelrhodopsin reveals  
experience-dependent influences on courtship**

Hidehiko K. Inagaki<sup>1,2,4</sup>, Yonil Jung<sup>1,2,4</sup>, Eric D. Hoopfer<sup>1,2</sup>, Allan M. Wong<sup>1,2</sup>, Neeli Mishra<sup>2</sup>, John Y. Lin<sup>1,3</sup>, Roger Y. Tsien<sup>1,3</sup>, and David J. Anderson<sup>1,2</sup>

<sup>1</sup> Howard Hughes Medical Institute, <sup>2</sup> Division of Biology 156-29, California Institute of Technology, Pasadena, California 91125, USA. <sup>3</sup> Department of Pharmacology, University of California, San Diego, La Jolla, California 92093, USA. <sup>4</sup>These authors contributed equally to this work. Correspondence should be addressed to D.J.A. (wuwei@caltech.edu).

**Supplementary information**

<b>Supplementary Figure 1</b>	<b>Detail of the behavioral experimental setup</b>
<b>Supplementary Figure 2</b>	<b>Expression of ReaChR in the brain and ReaChR-based activation of behaviors with different frequencies</b>
<b>Supplementary Figure 3</b>	<b>ReaChR-based activation of P1 neurons</b>

<b>Supplementary Table 1</b>	<b>List of transgenic flies created for this paper</b>
<b>Supplementary Table 2</b>	<b>List of materials to build LED-based high-throughput screening system</b>
<b>Supplementary Table 3</b>	<b>Summary of properties of neurons controlling wing extension</b>
<b>Supplementary Table 4</b>	<b>Primers used in this paper</b>

<b>Supplementary Note</b>	<b>Discussion regarding why ReaChR was more effective than other channelrhodopsins</b>
<b>Supplementary Software</b>	<b>Software to control LED and camera for behavioral experiments</b>

<b>Supplementary Video 1</b>	<b>Activation of Gr5a neurons with ReaChR (1.1 MB)</b>
<b>Supplementary Video 2</b>	<b>Activation of HB9 GAL4 neurons with ReaChR (610 KB)</b>
<b>Supplementary Video 3</b>	<b>Activation of Crz GAL4 neurons with ReaChR (1.4 MB)</b>
<b>Supplementary Video 4</b>	<b>Activation of Fru GAL4 neurons with ReaChR (655 KB)</b>
<b>Supplementary Video 5</b>	<b>Activation of P1 and pIP10 neurons with ReaChR (1.2 MB)</b>

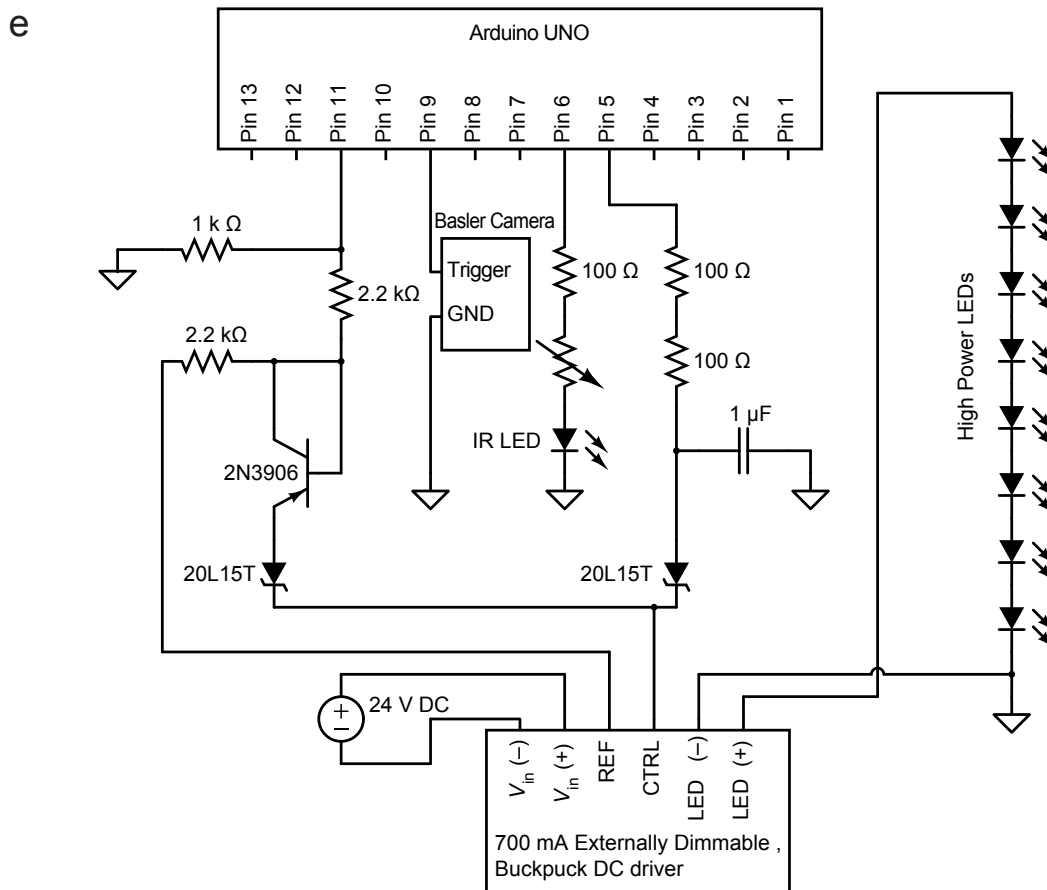
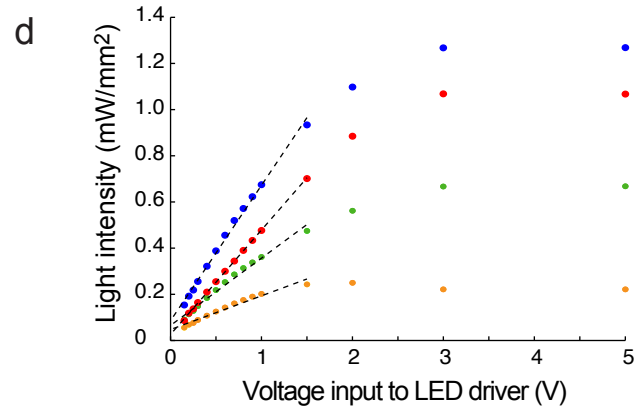
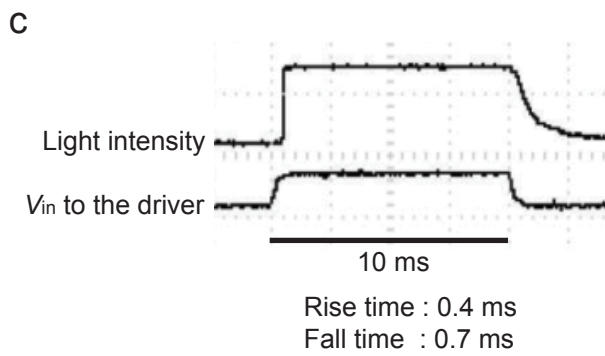
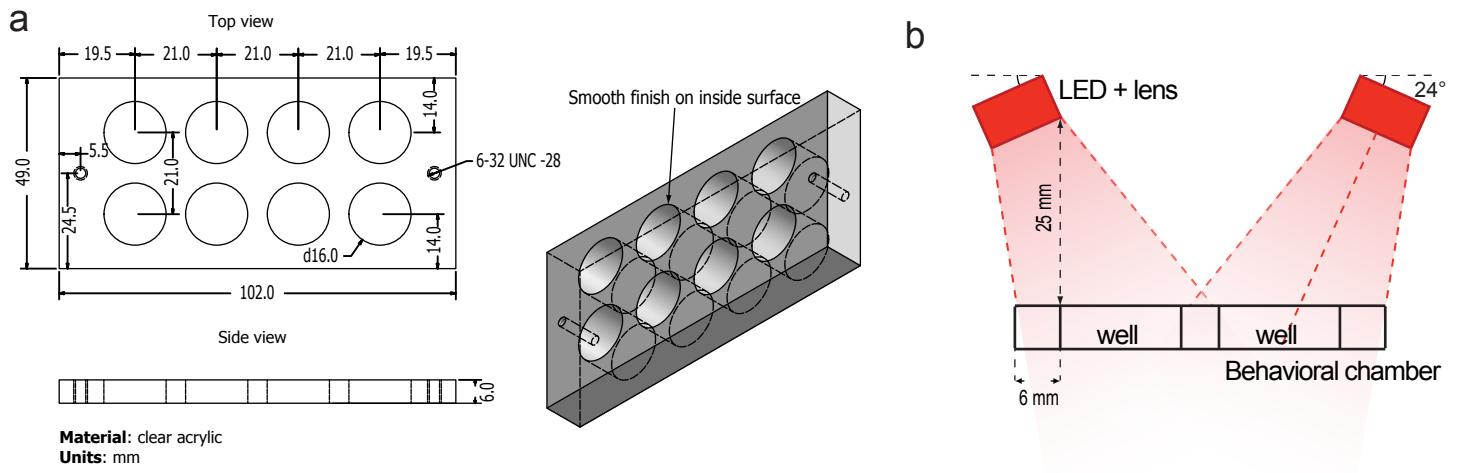

Supplementary Figure 1

## **Supplementary Figure 1 | Detail of the behavioral experimental setup.**

(a) Design of the behavioral chamber. A top plate with holes to introduce flies into the chambers (not shown here), and a bottom plate (not shown here), are attached with screws to this behavioral chamber. (b) Alignment of LEDs with the behavioral chamber. Light beams are angled towards the center of the behavioral wells. Each LED delivers light to each well. (c) Light intensity of the LED and voltage input from the Arduino UNO board (Smart Projects, Italy) to the LED driver were simultaneously monitored. Start-up delay of LED is 0.4 msec and turn-off delay of LED is approximately 0.7 msec. (d) Relationship of light intensity inside the behavioral chamber and voltage input to the LED driver. Points with different color represent LEDs of different wavelengths (Red: 627 nm, Amber: 590 nm, Green: 530 nm, Blue: 470 nm). Dotted lines indicate linear dynamic ranges for each type of LED. (e) Electric circuit diagram for the LED controller. This circuit was built on a custom Arduino shield. With the Arduino program (downloadable from the online version of this paper), this electric circuit controls high power LEDs. Intensity, pulse width, pulse frequency, length of pulse train, and the number of and interval between repeated pulse trains are controllable for up to 8 of 700 mA LEDs in parallel.

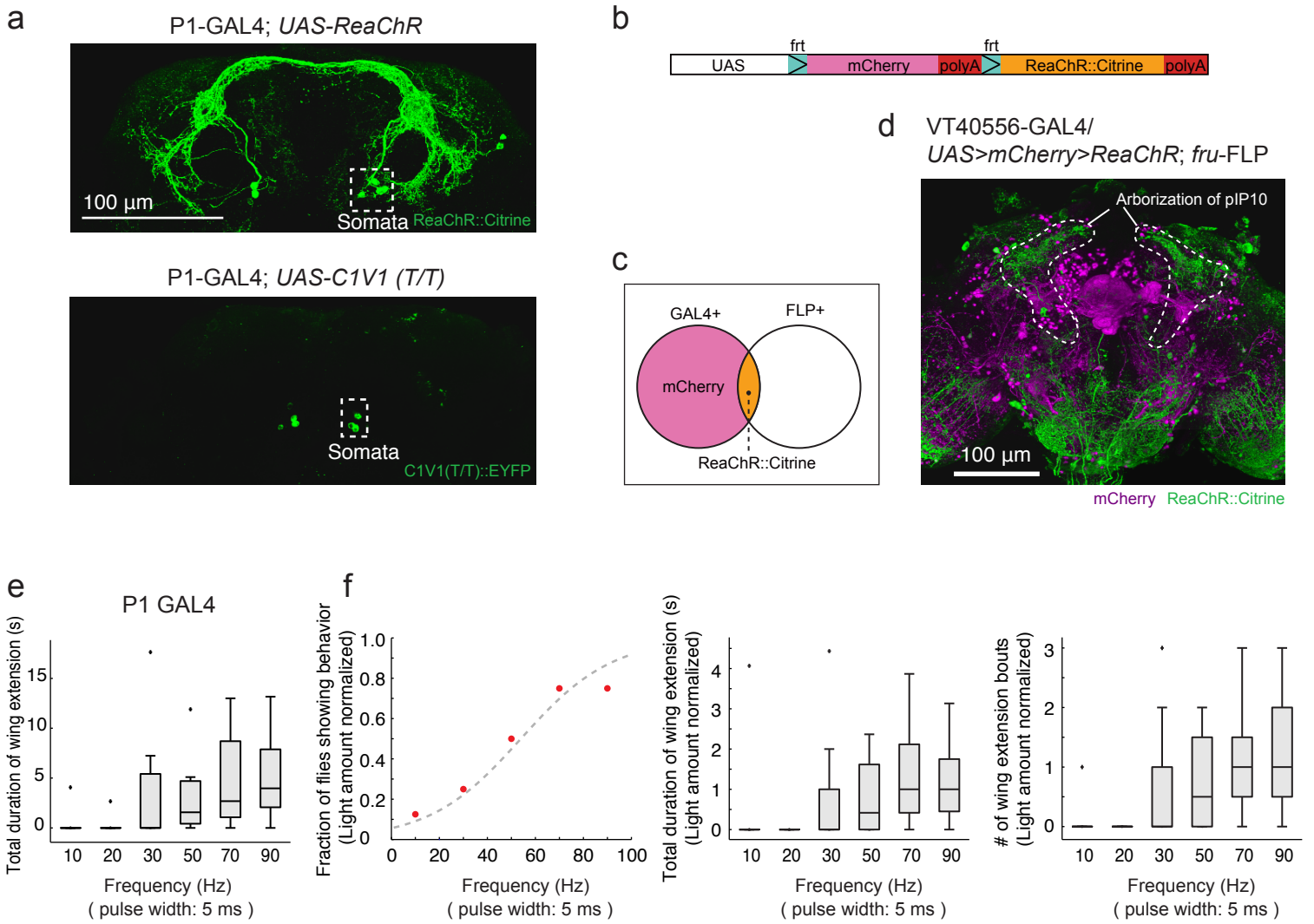

Supplementary Figure 2

**Supplementary Figure 2 | Expression of ReaChR in the brain and ReaChR-based activation of behaviors with different frequencies.**

(a) Expression and trafficking of ReaChR (top) and C1V1(T/T) (bottom) in P1 neurons in adult flies. Note that both opsins are expressed at cell somata (box with a white dotted line), but only ReaChR is trafficked to the arborizations. Both of the opsins are visualized with a citrine or YFP tag immunostained with anti-GFP antibody. (b) Design of the *UAS-*frt-mCherry-*frt-ReaChR*** transgene (Note that ReaChR is tagged with citrine). (c) Diagram representing the intersectional approach for labeling pIP10 neurons. (d) Representative confocal projection of whole-mount brain from VT40556 (*GAL4*) / *UAS-*frt-mCherry-*frt-ReaChR*** (*UAS>stop>ReaChR*) (*attP40*); *fru-FLP* flies. (e) Relationship between pulse stimulation frequencies and total duration of wing extensions in flies expressing ReaChR in P1 neurons (*P1-GAL4*; *UAS-ReaChR* (VK5)). Parameters are extracted from the same data used for Fig. 2e. Boxplot properties are as in Fig. 2. (f) Relationships of frequencies of light pulses and behavior in flies expressing ReaChR in P1 neurons, after normalization for the total amount of light delivered at different frequencies. For normalization purpose, behaviors during different durations of light activation were counted (first 60, 30, 20, 12, 8.57, and 6.67 sec during the activation for 10, 20, 30, 50, 70, 90 Hz, respectively). Parameters are extracted from the same data used for Fig. 2e. Boxplot properties are as in Fig. 2.

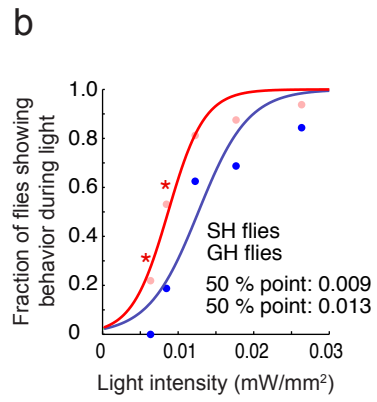
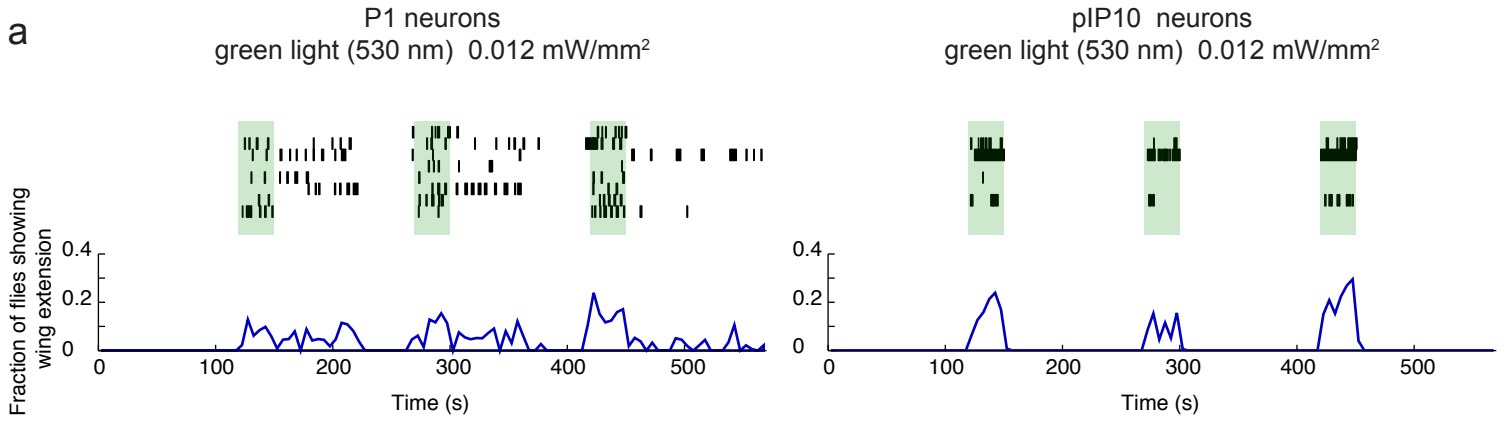

Supplementary Figure 3

### Supplementary Figure 3 | ReaChR- based activation of P1 neurons.

(a) Activation of P1 neurons (P1-GAL4; *UAS-ReaChR*(VK5) (left) and pIP10 neurons (VT40556/*UAS>stop>ReaChR* (attP40); *fru-FLP*) (right) with green light (530 nm, 0.012 mW/mm<sup>2</sup>). Top: Raster plot representing wing extension bouts ( $n = 8$  flies per genotype). Green bars represent 60 sec continuous photostimulation with 300 sec inter-trial intervals. Bottom: Fraction of flies showing wing extension (time bins: 5 sec). Note that regardless of photostimulation conditions (see also Figs. 3,4), ReaChR-based activation of P1 neurons triggers stochastic and persistent wing extensions. (b) Fraction of P1-GAL4; *UAS-ReaChR*(VK5) flies showing wing extension during a single photostimulation trial as a function of light intensity (green light: 530 nm, continuous, 30 sec). The data were fitted by a sigmoidal function to calculate the 50 % point.  $n = 32$  for each intensity. (blue points) are the same as red point used in Fig. 3f, and are replotted here for purposes of comparison \*:  $P < 0.05$ .  $P$ -values represent Friedman's test comparing SH vs. GH ( $P = 0.02$ ) followed by Fisher's exact test with Bonferroni correction comparing SH vs. GH at each intensity of light.

**Supplementary Table 1 | List of transgenic flies created for this paper**

#	Name	Opsin	tag	plasmid	attP landing site
1	UAS-ReaChR	ReaChR	Citrine	pJFRC2 (10x UAS with IVS)	attP40 (II)
2	UAS-ReaChR	ReaChR	Citrine	pJFRC2 (10x UAS with IVS)	Su(Hw) attP5 (II)
3	UAS-ReaChR	ReaChR	Citrine	pJFRC2 (10x UAS with IVS)	VK00005 (III)
4	LexAop-ReaChR	ReaChR	Citrine	pJFRC19 (10x LexAop with IVS)	Su(Hw) attP5 (II)
5	LexAop-ReaChR	ReaChR	Citrine	pJFRC19 (10x LexAop with IVS)	VK00005 (III)
6	UAS-frt-mCherry-frt-ReaChR	ReaChR	Citrine	pJFRC2 (10x UAS with IVS) with frt cassette	Su(Hw) attP5 (II)
7	UAS-frt-mCherry-frt-ReaChR	ReaChR	Citrine	pJFRC2 (10x UAS with IVS) with frt cassette (	VK00005 (III)
8	LexAop-frt-mCherry-frt-ReaChR	ReaChR	Citrine	pJFRC19 (10x LexAop with IVS) with frt cassette	Su(Hw) attP5 (II)
9	LexAop-frt-mCherry-frt-ReaChR	ReaChR	Citrine	pJFRC19 (10x LexAop with IVS) with frt cassette	VK00005 (III)
10	UAS-C1V1	C1V1 (T/T)	EYFP	pJFRC2 (10x UAS with IVS)	Su(Hw) attP5 (II)
11	UAS-C1V1	C1V1 (T/T)	EYFP	pJFRC2 (10x UAS with IVS)	VK00005 (III)
12	LexAop-C1V1	C1V1 (T/T)	EYFP	pJFRC19 (10x LexAop with IVS)	Su(Hw) attP5 (II)
13	LexAop-C1V1	C1V1 (T/T)	EYFP	pJFRC19 (10x LexAop with IVS)	VK00005 (III)

#	Name	X	II	III
14	UAS-frt-mCherry-frt-ReaChR ; fru-FLP	w-	UAS-frt-mCherry-frt-ReaChR (attP5)	fru-FLP
15	UAS-ReaChR; UAS-GCaMP3	w-	UAS-ReaChR (attP40)	UAS-GCaMP3 (VK5)



**Supplementary Table 2 | List of materials to build LED-based high-throughput screening system**

This list is provided for the convenience of readers who wish to build similar setups. We are listing the company and product names that we used but alternatives may be used.

#	Category	Number	Note (company, ordering info, etc.)
---	----------	--------	-------------------------------------

**Camera related (i, iv & v in Fig. 2a, b)**

1	<b>Camera</b>	1	We used Basler A622FM 2/3" CMOS FireWire Monochrome Camera (640 x 480 pixels up to 100 fps) (Basler Inc. Exton, PA USA. <a href="http://www.baslerweb.com/">http://www.baslerweb.com/</a> ).
2	<b>Lens for camera</b>	1	Varifocal Video Lens 12 mm – 36mm 1 : 2.8 Focal Length 2/3" C mount (Edmund Optics, Barrington, NJ 08007-1380 USA, <a href="http://www.edmundoptics.com/">http://www.edmundoptics.com/</a> )
3	<b>IR filter</b>	1	A long-pass filter on the lens of the camera to remove the light from high-power LEDs. We used longpass filter (pass wavelengths longer than 780 nm). LP780-M40.5 (Midwest Optical Systems, Inc. Palatine, IL USA. <a href="http://www.midopt.com/">http://www.midopt.com/</a> ).
4	<b>IR backlight</b>	1	Backlight to visualize flies in behavioral chamber. We used SOBL-200-150-IR 850 nm (Smart Vision Lights. Muskegon, MI, USA. <a href="http://smartvisionlights.com/">http://smartvisionlights.com/</a> )
5	<b>PC</b>	1	
6	<b>Software and driver to record movies from the camera</b>	1	We used CMU 1394 Digital camera driver ( <a href="http://www.cs.cmu.edu/~iwan/1394/index.html">http://www.cs.cmu.edu/~iwan/1394/index.html</a> ) with gVision ( <a href="http://gvision-hhmi.sourceforge.net/">http://gvision-hhmi.sourceforge.net/</a> ) or a custom made Matlab software (Mathworks).
7	<b>Bread board, optical, posts and connectors to assemble the behavioral rig</b>	N.A.	Acquired from Thorlab, Inc (Newton, New Jersey, USA. <a href="http://www.thorlabs.com/index.cfm">http://www.thorlabs.com/index.cfm</a> ).

**LED related and its controller (ii, iii & v in Fig. 2 a, b)**

8	<b>High power LED (blue)</b>	8	Blue (470 nm) Rebel LED, mounted on a 10 mm square cool base- 70 lm @ 700 mA (LUXEON® STAR LEDs: SR-05-B0040). Spectral half-width (spectral width at ½ of the peak intensity) is 20 nm.
---	------------------------------	---	--

			(#8–15 are acquired from Quadica Developments Inc. Ontario N3T 5L7 Canada. <a href="http://www.luxeonstar.com/default.asp">http://www.luxeonstar.com/default.asp</a> )
9	<b>High power LED (green)</b>	8	Green (530 nm) Rebel LED, mounted on a 10 mm square cool base- 161 lm @ 700 mA (LUXEON® STAR LEDs: SR-05-M0100). Spectral Half-width is 30 nm.
10	<b>High power LED (amber)</b>	8	Amber (590 nm) Rebel LED, mounted on a 10 mm square cool base- 77 lm@ 700mA (LUXEON® STAR LEDs: SR-05-L0040). Spectral Half-width is 20 nm.
11	<b>High power LED (red)</b>	8	Red (627 nm) Rebel LED, mounted on a 10 mm square cool base- 102 lm @ 700 mA (LUXEON® STAR LEDs: SR-05-D2050) Spectral Half-width is 20 nm.
12	<b>Optics for LEDs</b>	32	All of the LEDs were used with optics. 29.8° 10 mm Frosted optic with integrated mounting legs (Carclo)
13	<b>Heat conductive seal</b>	32	To seal LEDs to the heat sink (LUXEON® STAR LEDs: LXT-R-10)
14	<b>Heat sink for LEDs</b>	16	All the LEDs were attached to heat sinks to avoid overheat (LUXEON® STAR LEDs: N50-25B)
15	<b>LED driver</b>	1	700 mA Externally dimmable, Buckpuck DC driver with leads (LUXEON® STAR LEDs: 3023-D-E-700)
16	<b>Power supply</b>	1	Any power driver that is capable of supplying 700mA 32V DC.
17	<b>850nm indicator LED</b>	1	Because IR filter filters out the light from high power LEDs, the only way to know when the light is on is information from the LED controller. We placed one IR LED whose on/off is synchronized to the high power LED so that we can easily tell when LEDs are on in the movie.
18	<b>Arduino Uno</b>	1	Microcontroller to control camera and LEDs (Smart Projects, Italy. <a href="http://www.arduino.cc/">http://www.arduino.cc/</a> )
19	<b>Electric parts to build an Arduino shield to control the LEDs</b>	N.A.	See Supplementary Fig. 1e for the circuit designs and parts.
20	<b>Code to control Arduino UNO board</b>	1	The code we used is available on online version of this paper
21	<b>Behavioral chamber</b>		The design of the chamber and the alignment of chamber and LEDs are described in Supplementary Fig. 1a, b. Any kind of chamber can be used but it is necessary to measure light intensity and to make sure uniform illumination.

**Supplementary Table 3 | Summary of properties of neurons controlling wing extension**

	P1 neuron	pIP10 neuron
Probability of response	Stochastic	Deterministic
Timing of response	Variable onset/offset	Time-locked to stimulus onset/offset
Modulation by social state	Yes	No
Class of neuron	State control / Biasing neuron	Command neuron

**Supplementary Table 4 | Primers used in this paper**

5F-EcoRI-chr2	CGGAATTCACCCatggactatggcggcgctttg
3R-2a-YFP	ctccagaacctgatctcttagcccgctgtacagctcgtccatgccg
5F-2a-Chr2	ggagtccaaccaggggcccatggactatggcggcgctttg
3R-Xba-YFP	GCTCTAGAttactgtacagctcgtccatgccg
5F-2a	cgggctaagagatcaggttctggagcaccagtgaacagacttgaattttgaccttctcaagttggcagga gacgtggagtccaaccaggggccc
3R-2a	gggccctgggttgactccacgtctcctgccaactgagaaggtaaaattcaaagtctgttactggtgct ccagaacctgatctcttagcccg
C1V1-f	TCTTATCCTTTACTTCAGGCCAAAATGTCGCGGAGGCCATGGCTT CTTGCCCTA
C1V1-EGFP-r	GGTTCCTTCACAAAGATCCTTCTCGGCATGGACGAGCTGTACAA GTGA
ReaChR-f	TCTTATCCTTTACTTCAGGCCAAAATGGTGAGCAGAAGACCCTG
ReaChR-citrine-r	GGTTCCTTCACAAAGATCCTCTAGACTACTTGTACAGCTCGTCCA TGC

**Supplementary Note** | Discussion regarding why ReaChR was more effective than other channelrhodopsins

Several factors may explain why ReaChR was more effective than other channelrhodopsins tested in intact adult flies. First and foremost, longer wavelengths of light have better penetration through the cuticle. Second, ReaChR has slower off-kinetics ( $137 \pm 7$  msec)<sup>17</sup> than the most of other ChR2 variants we tested (c.a. 10-20 msec)<sup>2,3</sup>, making the channel more light-sensitive (but note that C128T has even longer off-kinetics: 2 sec)<sup>21</sup>. Finally, the membrane transport or expression of C1V1(T/T) is much lower than that of ReaChR. Although it is possible that ReaChR is simply expressed and/or transported more efficiently than the other opsins tested, a direct comparison is difficult because they are tagged with different fluorescent proteins.

**Supplementary Software** | Software to control LED and camera for behavioral experiments

This custom software was written to control high-power LED and CCD/CMOS camera for behavioral setups we described in Fig. 2a. See Supplementary Table 2 for the list of materials required to build the setup. This software was developed using the Arduino computer language (version 1.0, Arduino software). In addition to the Arduino core installation and this software, Timer1 (<http://playground.arduino.cc/code/timer1>) and MS Timer2 (<http://playground.arduino.cc/Main/MsTimer2>) libraries are required. Software compatibility was only verified for PCs with a Windows 7 64-bit operating system and Mac OS X. See the code for instructions (instructions are provided as comments in the first part of the code).

### **Supplementary Video 1 | Activation of Gr5a neurons with ReaChR**

This movie shows representative PER behavior triggered by activation of Gr5a neurons with ReaChR. The first half of the movie shows activation with pulsing light-stimuli (100 msec pulse width, 1 Hz, 627 nm), and the last half of the movie shows activation with a continuous light-stimulus (627nm). The white light appears on the right side of the movie is the light from the indicator IR LED (850 nm), which the flies cannot see.

### **Supplementary Video 2 | Activation of HB9 neurons with ReaChR**

This movie shows representative side-walking (first half of the movie) and paralysis (last half of the movie) triggered by activation of HB9-GAL4 neurons with ReaChR (continuous, 530 nm).

### **Supplementary Video 3 | Activation of Crz GAL4 neurons with ReaChR**

This movie shows representative ejaculation behavior triggered by activation of Crz-GAL4 neurons with ReaChR (continuous, 530 nm). Note that Crz-GAL4; *UAS-ReaChR* flies bend their abdomen and extrude their genitals from the abdomen. At the end of movie (around 14 sec) the fly ejaculates and stops bending it abdomen. Note that although the control fly on the right (empty-GAL4; *UAS-ReaChR*) shows abdominal bending several times, it is less frequent and not accompanied by genital extrusion or ejaculation.

#### **Supplementary Video 4 | Activation of Fru neurons with ReaChR**

This movie shows representative wing extension (first half of the movie) and paralysis (last half of the movie) triggered by activation of Fru-GAL4 neurons with ReaChR (continuous, 530 nm).

#### **Supplementary Video 5 | Activation of P1 and pIP10 neurons with ReaChR**

This movie shows representative wing extension behavior triggered by activation of P1 neurons (first half of the movie) and pIP10 neurons (last half of the movie) with ReaChR (continuous, 530 nm).