

Supplementary Figure S2

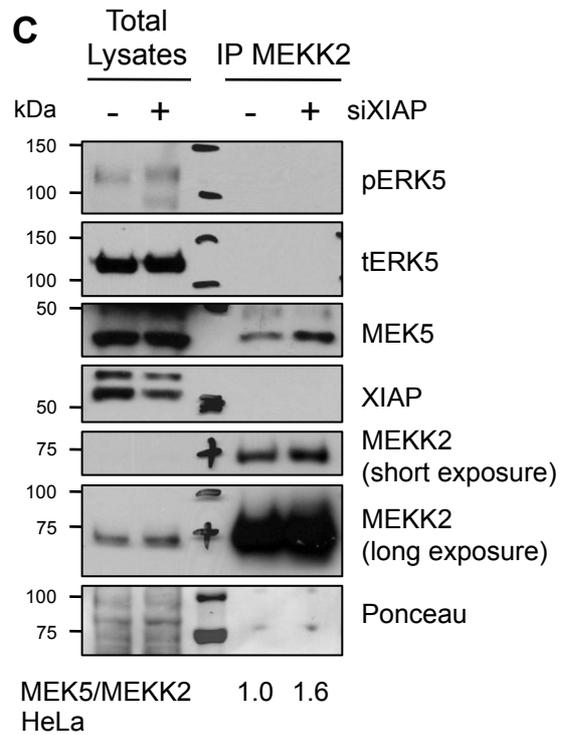
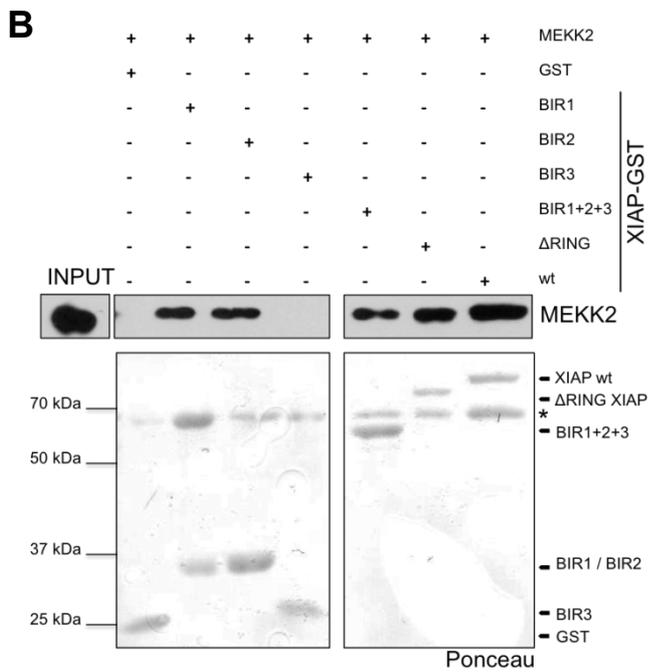
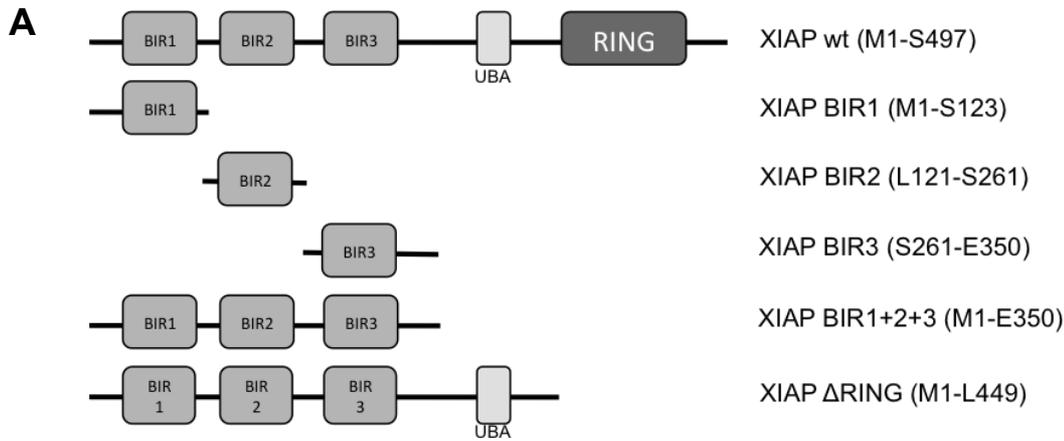

Supplementary Figure S2

(A) Details of XIAP GST-tagged constructs. (B) BIR1 and BIR2 bind to MEKK2 although with less affinity than full length XIAP. In vitro translated MEKK2-wt protein was incubated with different GST constructs of XIAP and GST pull-down was performed. The reticulolysates and GST fraction were analyzed by Ponceau staining and western blotting. Details of the XIAP constructs are shown in S2A. The BSA band was shown (*).

(C) Depletion of XIAP leads to an increase in MEK5 binding to MEKK2 *in vivo*. HeLa cells were transfected with siControl or siXIAP and endogenous MEKK2 was immunoprecipitated with the specific antibody. Total lysates and IP fraction were analyzed by western blotting.