

Photoacoustically guided wavefront shaping for enhanced optical focusing in scattering media—Supplementary Information

Puxiang Lai[†], Lidai Wang[†], Jian Wei Tay[†], and Lihong V. Wang^{*}

Optical Imaging Laboratory, Department of Biomedical Engineering, Washington University in St. Louis, St. Louis, Missouri 63130-4899

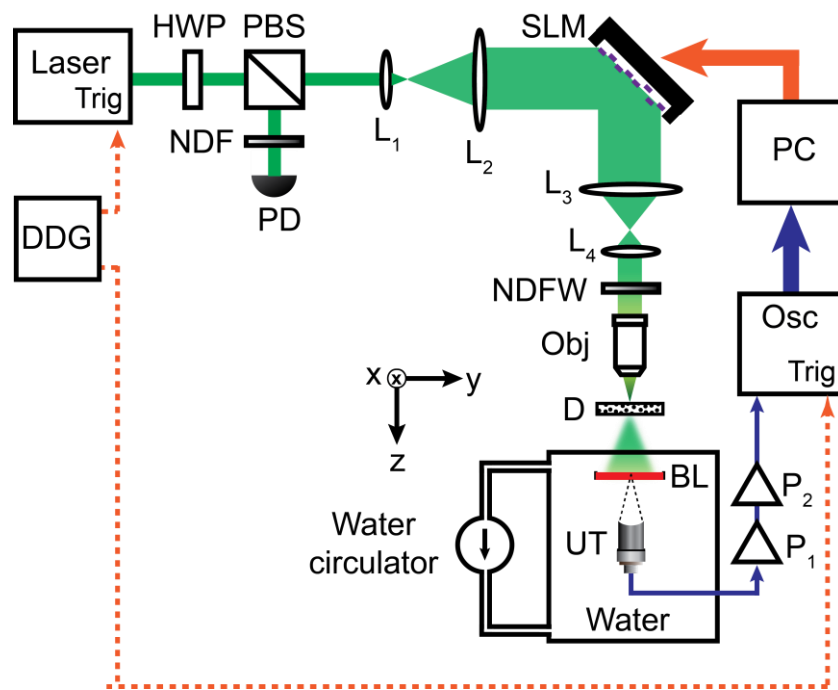

Supplementary Figure S1: Detailed diagram of the experimental PAWS setup. BL, blood layer; D, ground glass diffuser; DDG, digital delay generator; HWP, half-wave plate; L₁₋₄, lenses; NDF, neutral density filter; NDFW, neutral density filter wheel; Obj, microscopic objective (10×, 0.25 NA); Osc, oscilloscope; P₁₋₂, signal amplifiers; PBS, polarizing beam splitter; PC, computer; PD, photodiode; SLM, spatial light modulator; Trig, trigger signal; UT, ultrasonic transducer; x-y-z, coordinate system.

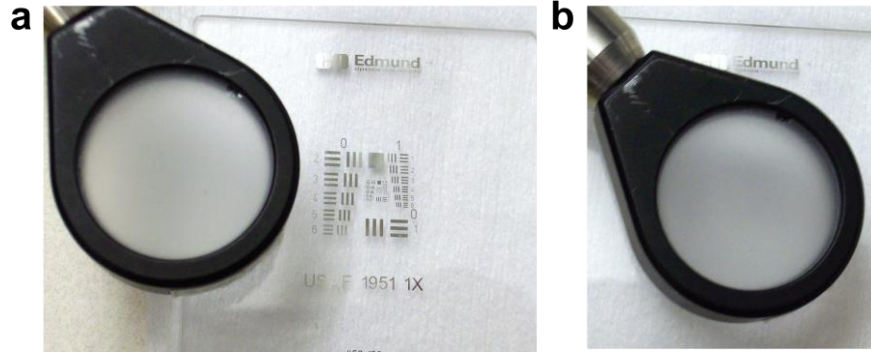

Supplementary Figure S2: Illustration of the turbidity of the ground glass diffuser. a. The ground glass and a 1951 USAF Contrast Resolution Target (#53-714, Edmund Optics, USA) put side by side. **b.** The ground glass diffuser put 10 mm above the USAF target. The resolution charts are completely invisible due to the strong scattering of the diffuser.

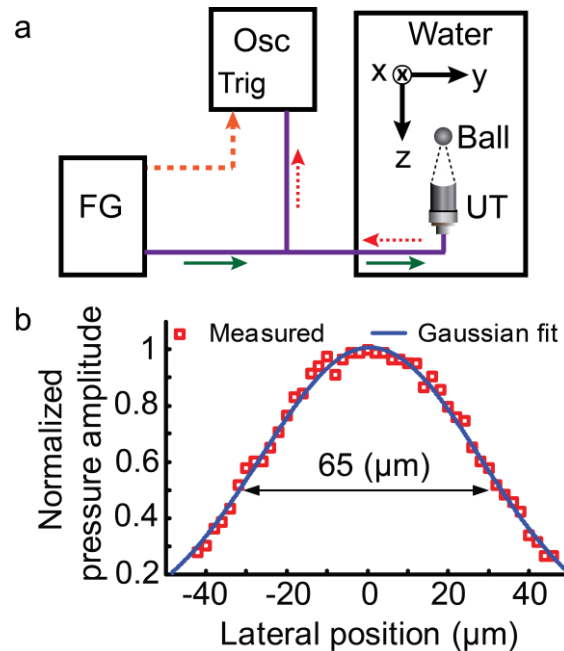

Supplementary Figure S3: Focus calibration of the 50 MHz ultrasonic transducer. a. Experimental setup for ultrasonic transducer calibration. A function generator (FG; DG4162, Rigol, USA) generates a burst including 10 cycles of 50 MHz sine waves, with a peak-to-peak amplitude of 5 V. The burst is sent to the ultrasonic transducer (UT), which emits an acoustic burst correspondingly. The acoustic wave is reflected by the metal ball, and received by the transducer. The echoed signal is digitized using an oscilloscope (Osc; TDS 5034, Tektronix, USA). The peak-to-peak value is proportional to the acoustic pressure amplitude at each position. In the experiment, the transducer is moved along the z direction first to determine the axial focal plane, and then scanned along the y direction to characterize the lateral profile at the focal plane. **b.** Calibrated acoustic sensitivity at the transducer focal plane, with a FWHM of 65 μm . The red squares are measured data, and the blue curve is a Gaussian fit. The acoustic focal profiles shown in **Figure 5** are based on the interpolation of the measured data.

Supplementary Movie 1: Illustration of linear PAWS optimization leading to an acoustic diffraction-limited optical pre-focusing.

Supplementary Movie 2: Illustration of nonlinear PAWS optimization leading to an optical diffraction-limited focusing.