

A ACUTE MYELOID LEUKEMIA

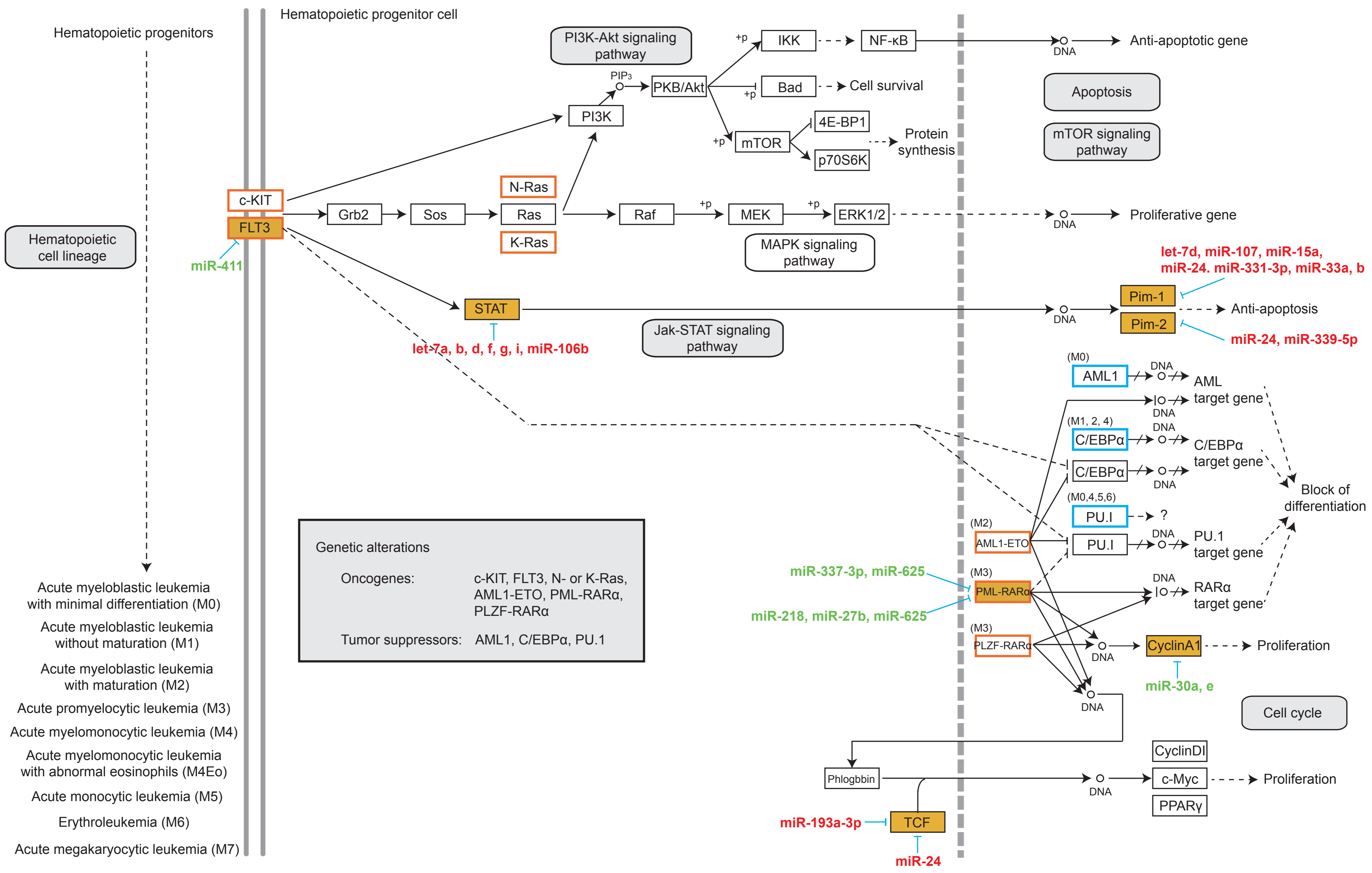

B CHRONIC MYELOID LEUKEMIA

