

S3 Fig. Maximum likelihood phylogenetic trees of each main cluster of NAC proteins.

Panel A. CL00003: OGs 1a-h

Groups 1a-h

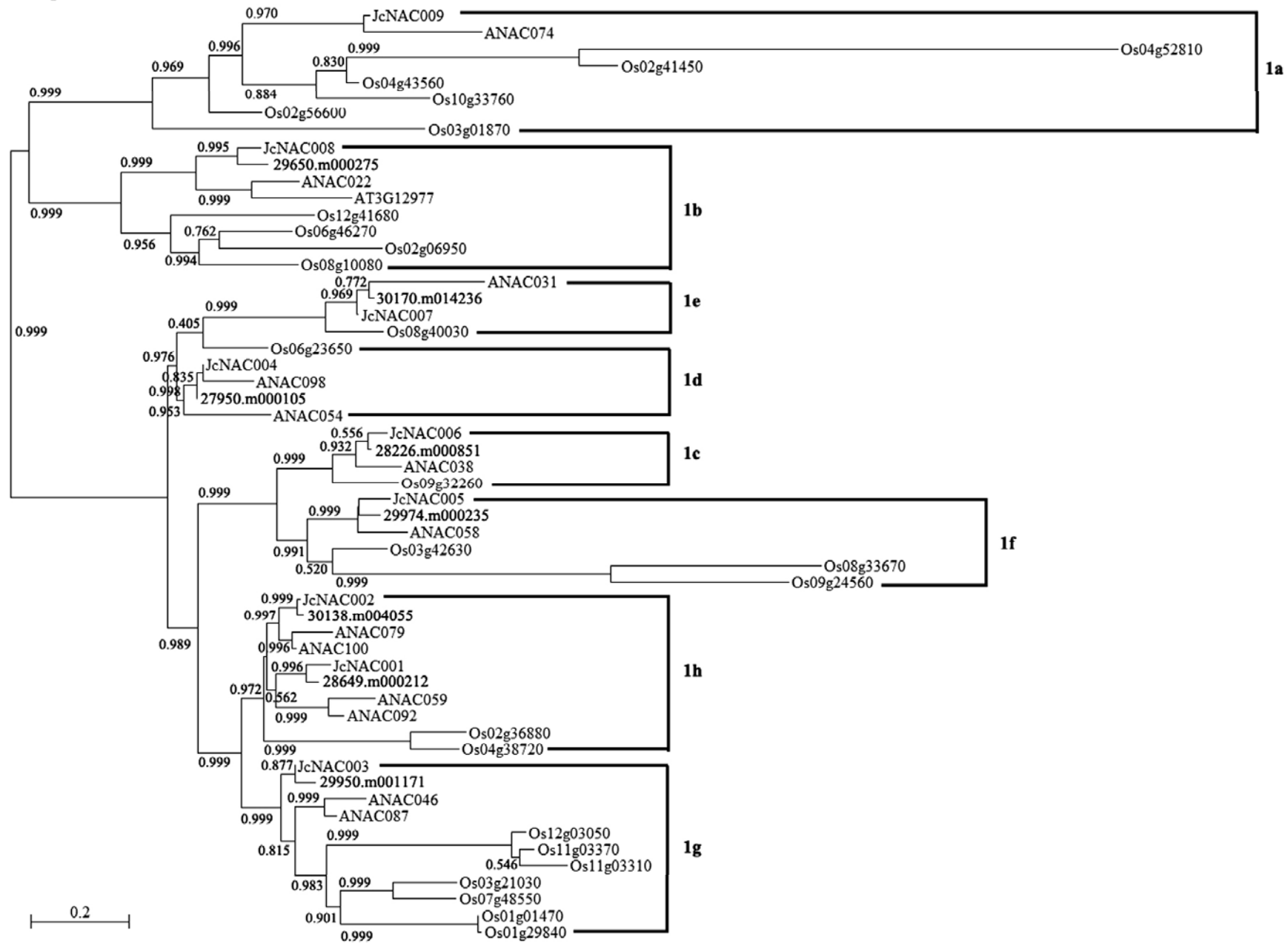

Panel B. CL000006: OGs 2a-f

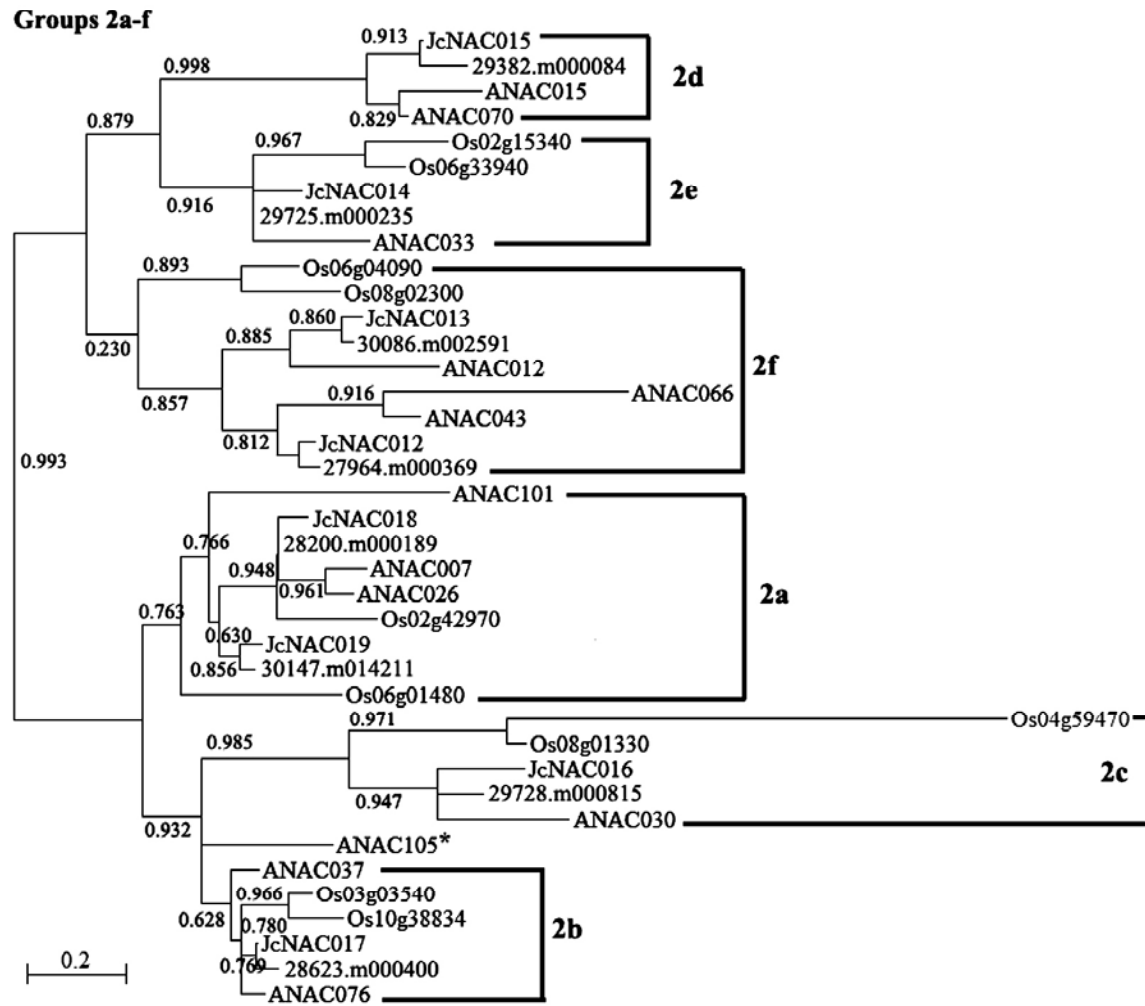

Panel C. CL000002: OGs 3a-e, 5a, 7e

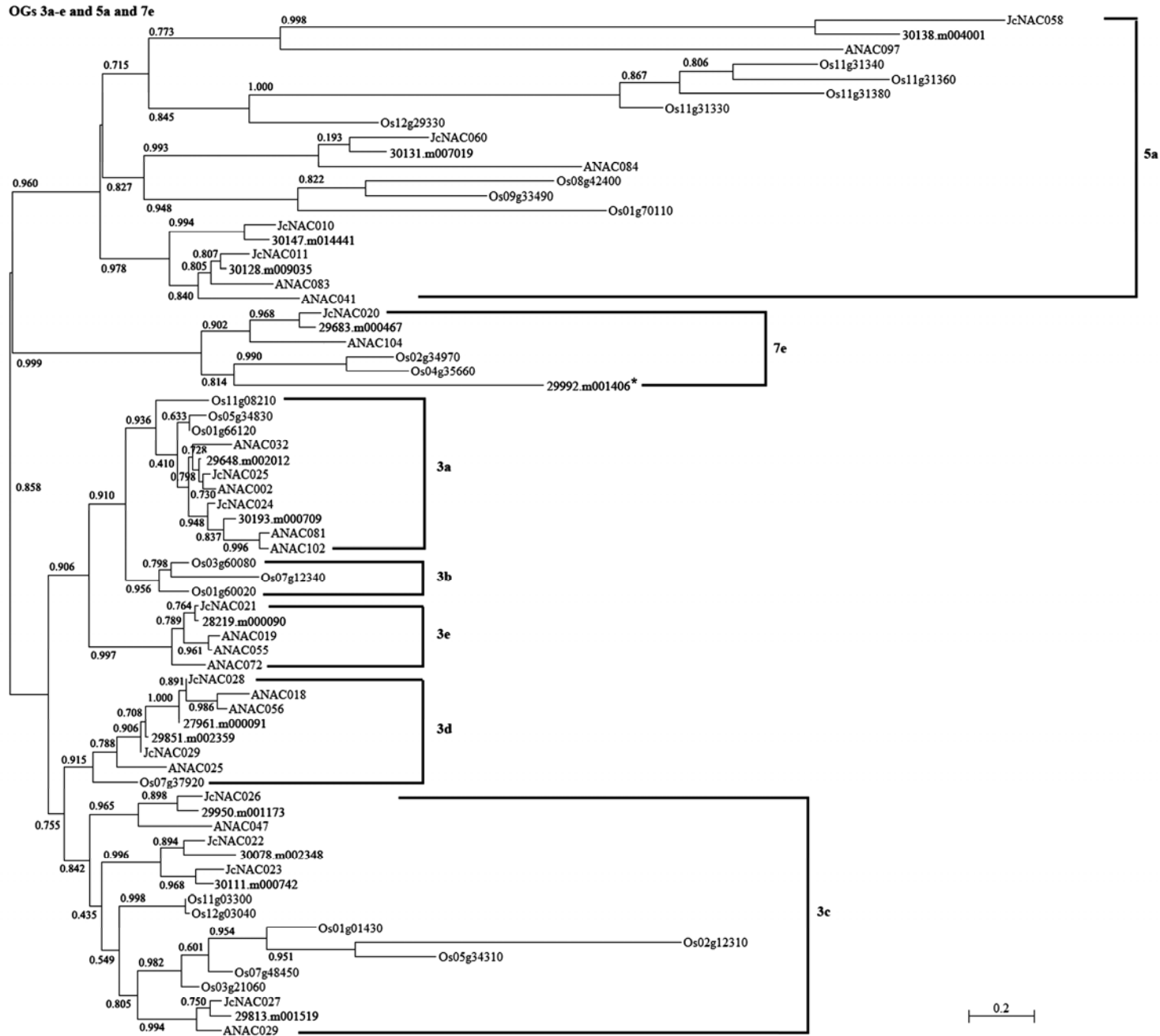

Panel D. CL000004: OGS 4a-g, 5b-c

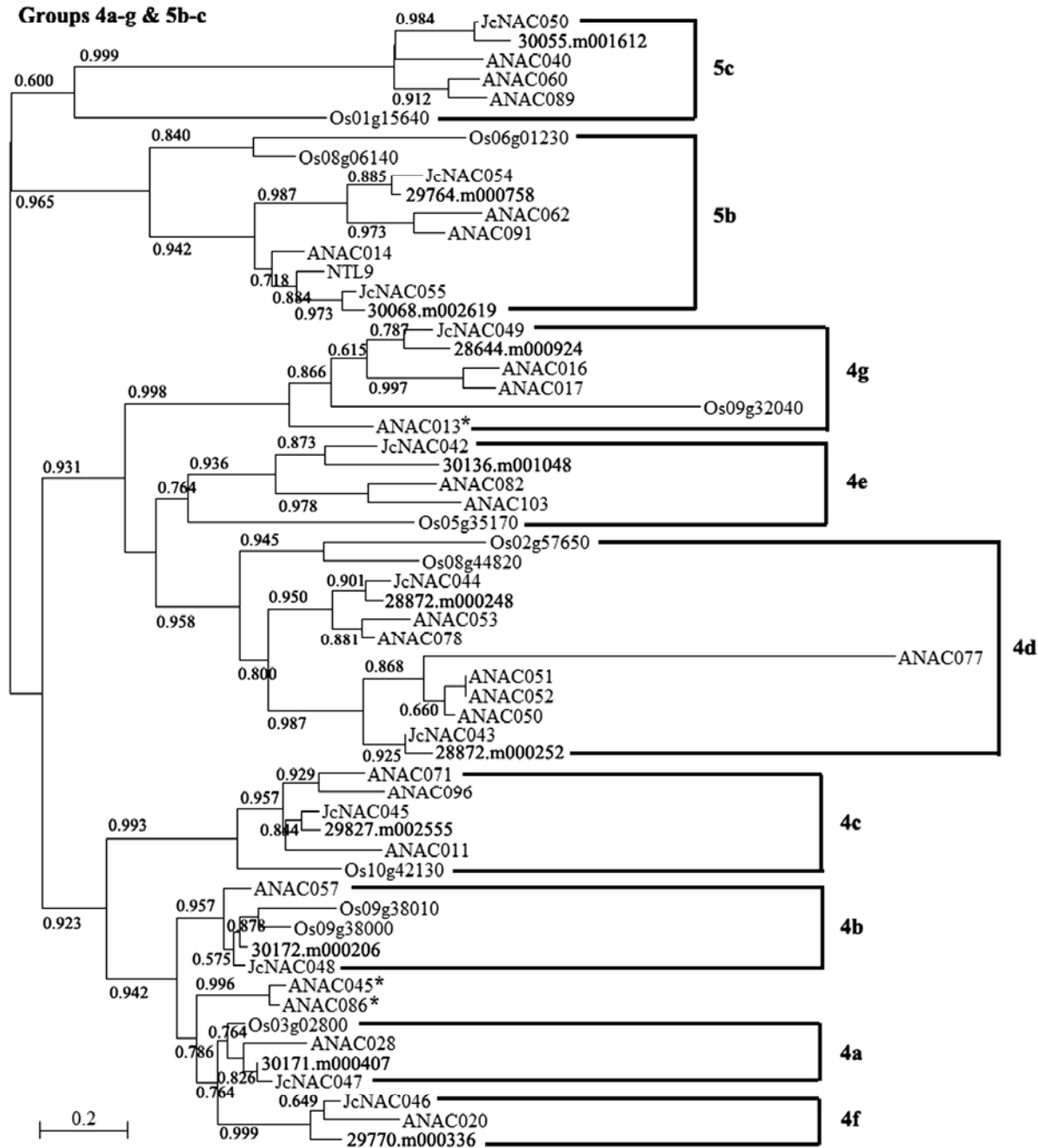

Panel E. CL000005: OGs 6a-c, 8a-b

Groups 6a-c & 8a-b

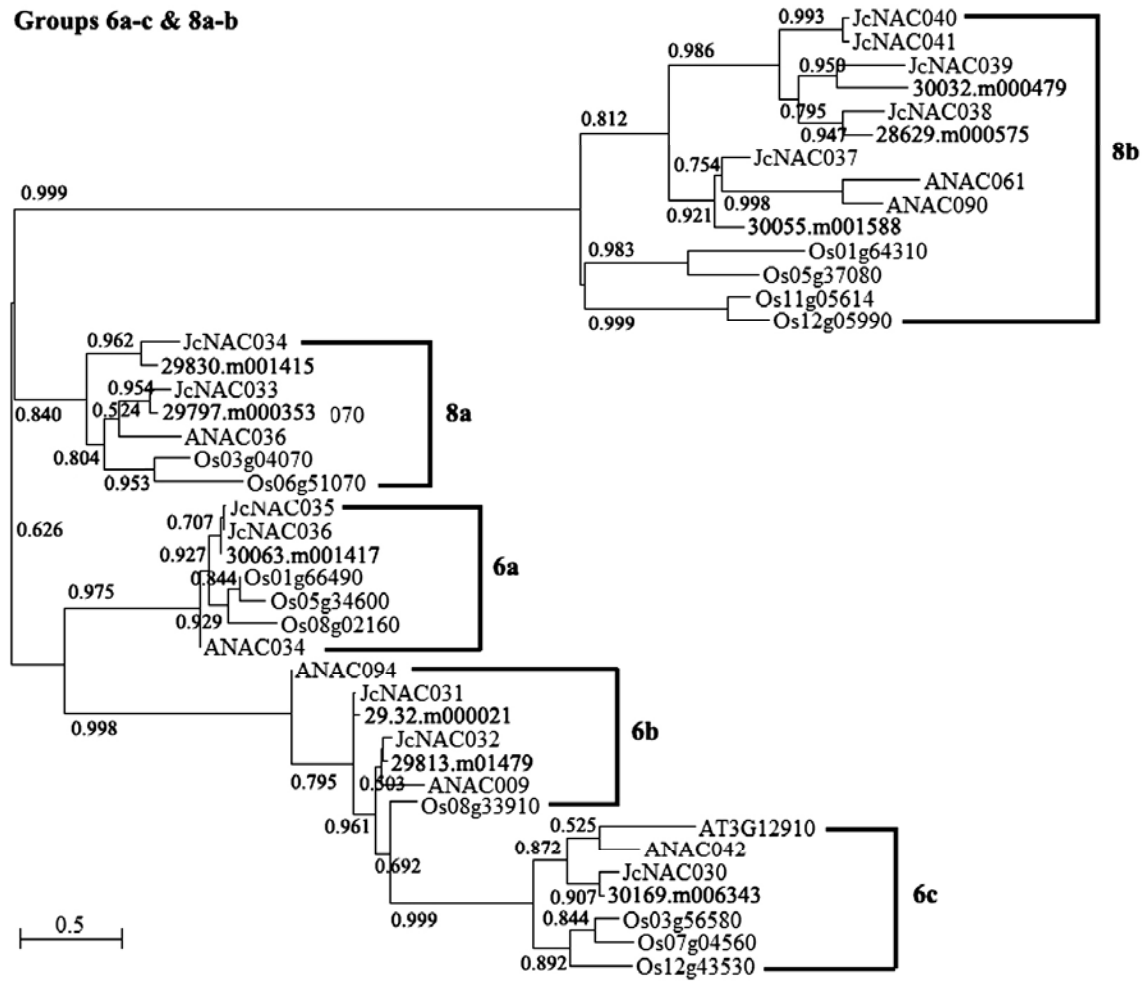

Panel F. CL000007: OGs 7a-d

Groups 7a-d

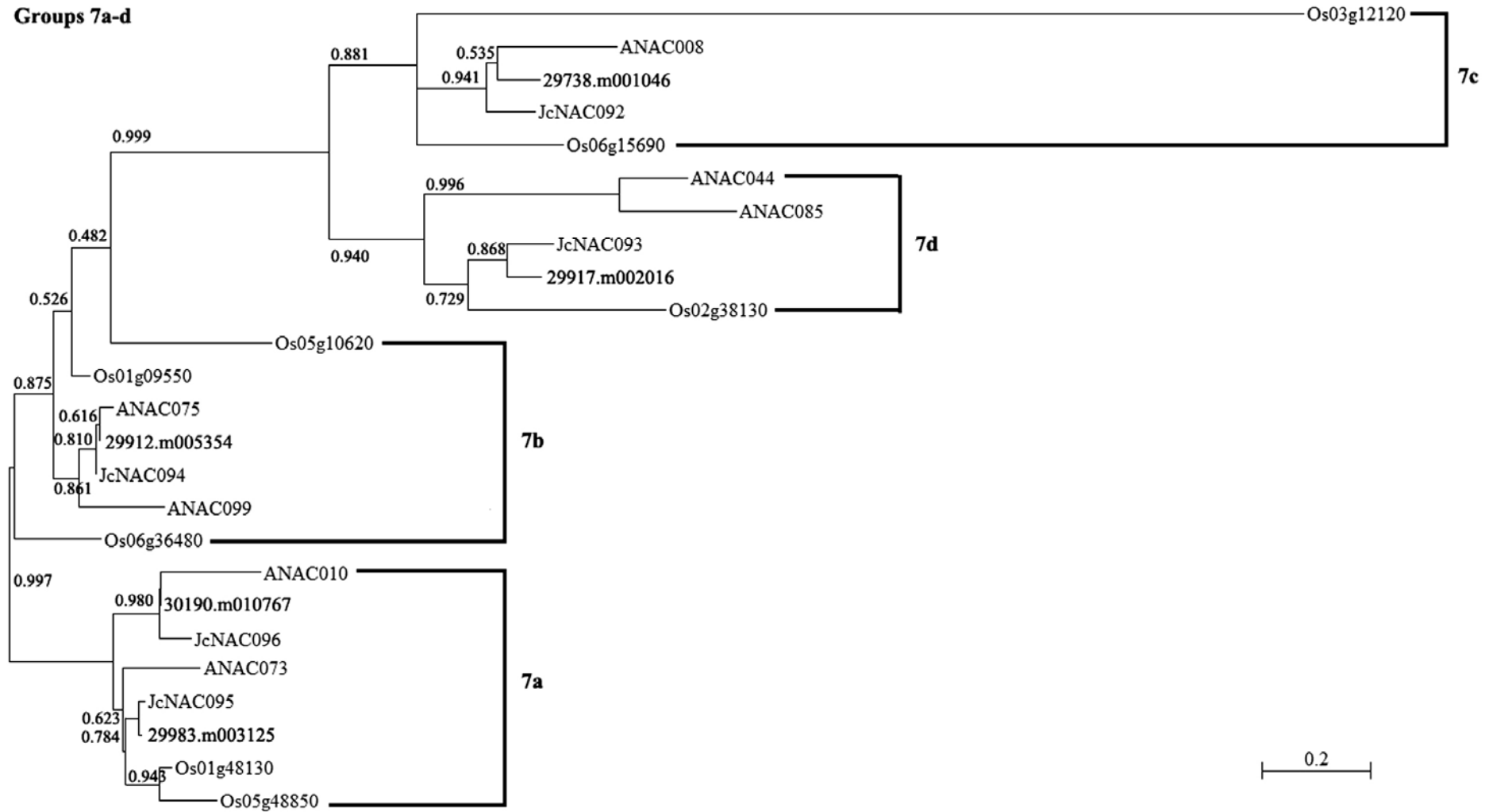

Panel G. Phylogenetic tree of unclassified NAC proteins from physic nut, Arabidopsis and rice

