

Additional file1

Table S1 MHC class IIB alleles detected in the fish owl samples used in the expression analysis.

Alleles observed in both genomic DNA and cDNA are shown in red; those found only in genomic DNA are shown in black.

Sample ID	Year	Region	Observed alleles	Number of alleles	
				Expressed	All
ID010	1985	KS	01, 02 , 03, 04, 05 , 06, 07, 08, 09, 10, 11 , 12	5	12
ID011	1986	AK	01 , 02, 03, 04, 05 , 06, 07, 08, 09, 11 , 12	3	10
ID012	1986	SR	01, 02, 03 , 04, 05 , 06, 07, 08, 09, 10 , 12, 17	6	13
ID014	1987	DS	01, 02, 03 , 04, 05, 07 , 09, 10 , 14	6	9
ID019	1988	KS	01, 02 , 03, 04, 05 , 06, 07, 08, 09, 10, 13	5	11
ID021	1989	SR	01, 02, 03 , 04, 05 , 06, 07, 08, 09, 10 , 12, 14, 15, 16, 17	6	15
ID025	1989	AK	01, 02 , 03, 04, 05 , 06, 07, 08, 09, 10, 11	5	11
ID028	1990	KS	01, 02, 03 , 04, 05 , 06, 07, 08, 09, 10, 11	6	11
ID034	1992	SR	01, 02 , 03, 04, 05 , 06, 07, 08, 09, 10, 11 , 12	5	12
ID038	1992	KS	01, 02 , 03, 04, 05 , 06, 07, 08, 09, 10, 11	5	11
ID043	1993	SR	01, 02, 03 , 04, 06, 07 , 08, 09, 12, 14, 15, 16, 17	6	13
ID046	1994	DS	01, 02, 03 , 04, 05 , 06, 07, 08, 09, 10 , 14	5	11
ID047	1994	DS	01, 02, 03 , 04, 05 , 06, 07 , 08, 09, 10, 11 , 12, 13 , 14	8	14
ID058	1995	SR	01, 02, 03 , 04, 05 , 06, 07, 08, 10	5	9
ID059	1996	SR	01, 02 , 03, 04, 05 , 06, 07, 08, 09, 10, 11 , 12	5	12
ID060	1996	DS	01, 02, 03 , 04, 05 , 06, 07, 08, 09, 10, 11 , 14	6	12

Table S2 Pairwise G_{ST} estimates (below diagonal) between the populations in the three periods. P -values (above diagonal) were obtained by permutation tests (1000 replications). Significant G_{ST} values ($P < 0.05$) are highlighted.

		Period1 (1963–1992)				Period2 (1993–2002)				Period3 (2003–2012)				
		SR	KS	AK	DS	SR	KS	AK	DS	SR	KS	AK	DS	HD
Period1 (1963–1992)	SR		0.013	0.876	0.967	0.969	0.071	0.451	0.557	1.000	0.112	0.045	0.556	0.264
	KS	0.0018		0.995	0.411	0.043	1.000	1.000	0.287	0.049	1.000	0.969	0.024	0.004
	AK	-0.0009	-0.0014		0.789	0.902	0.910	1.000	0.776	0.913	0.913	0.922	0.724	0.207
	DS	-0.0016	0.0001	-0.0014		0.898	0.305	0.537	1.000	0.983	0.408	0.257	0.987	0.621
Period2 (1963–2002)	SR	-0.0006	0.0013	-0.0007	-0.0011		0.007	0.442	0.487	1.000	0.019	0.004	0.889	0.218
	KS	0.0022	-0.0017	-0.0010	0.0003	0.0015		1.000	0.112	0.005	1.000	0.696	0.008	0.001
	AK	-0.0001	-0.0024	-0.0030	-0.0005	-0.0002	-0.0024		0.583	0.376	1.000	0.986	0.306	0.050
	DS	-0.0001	0.0005	-0.0007	-0.0026	-0.0002	0.0006	-0.0006		0.481	0.140	0.016	1.000	0.061
Period3 (2003–2012)	SR	-0.0009	0.0017	-0.0007	-0.0015	-0.0005	0.0021	0.0002	0.0000		0.004	0.001	0.563	0.155
	KS	0.0021	-0.0016	-0.0009	0.0000	0.0016	-0.0019	-0.0022	0.0007	0.0021		0.877	0.011	<0.001
	AK	0.0023	-0.0009	-0.0011	0.0008	0.0028	-0.0005	-0.0017	0.0023	0.0027	-0.0008		<0.001	<0.001
	DS	0.0000	0.0016	-0.0005	-0.0017	-0.0003	0.0020	0.0002	-0.0011	-0.0001	0.0022	0.0034		0.116
	HD	0.0012	0.0035	0.0010	-0.0005	0.0006	0.0039	0.0023	0.0013	0.0003	0.0040	0.0051	0.0006	

(A) Genomic DNA

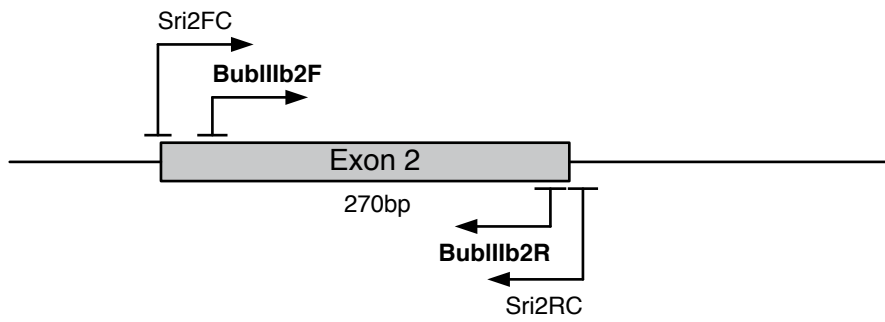

(B) cDNA

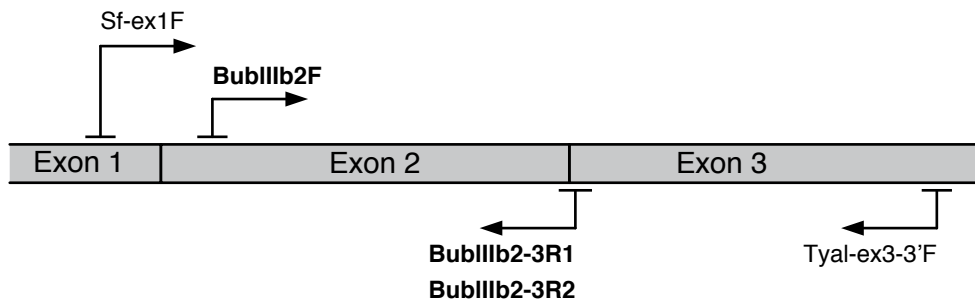
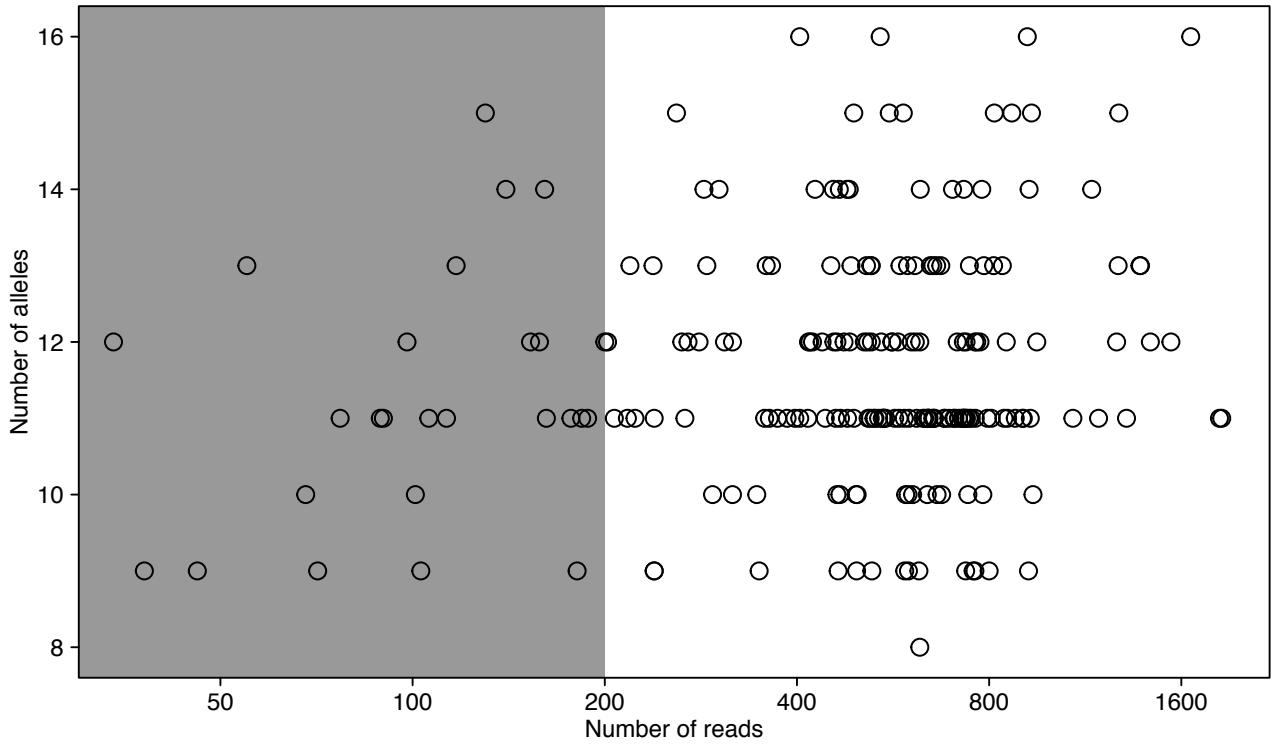

Figure S1 Location of primers used in the present study. Primer pairs used to amplify the fragments for pyrosequencing are shown in bold.



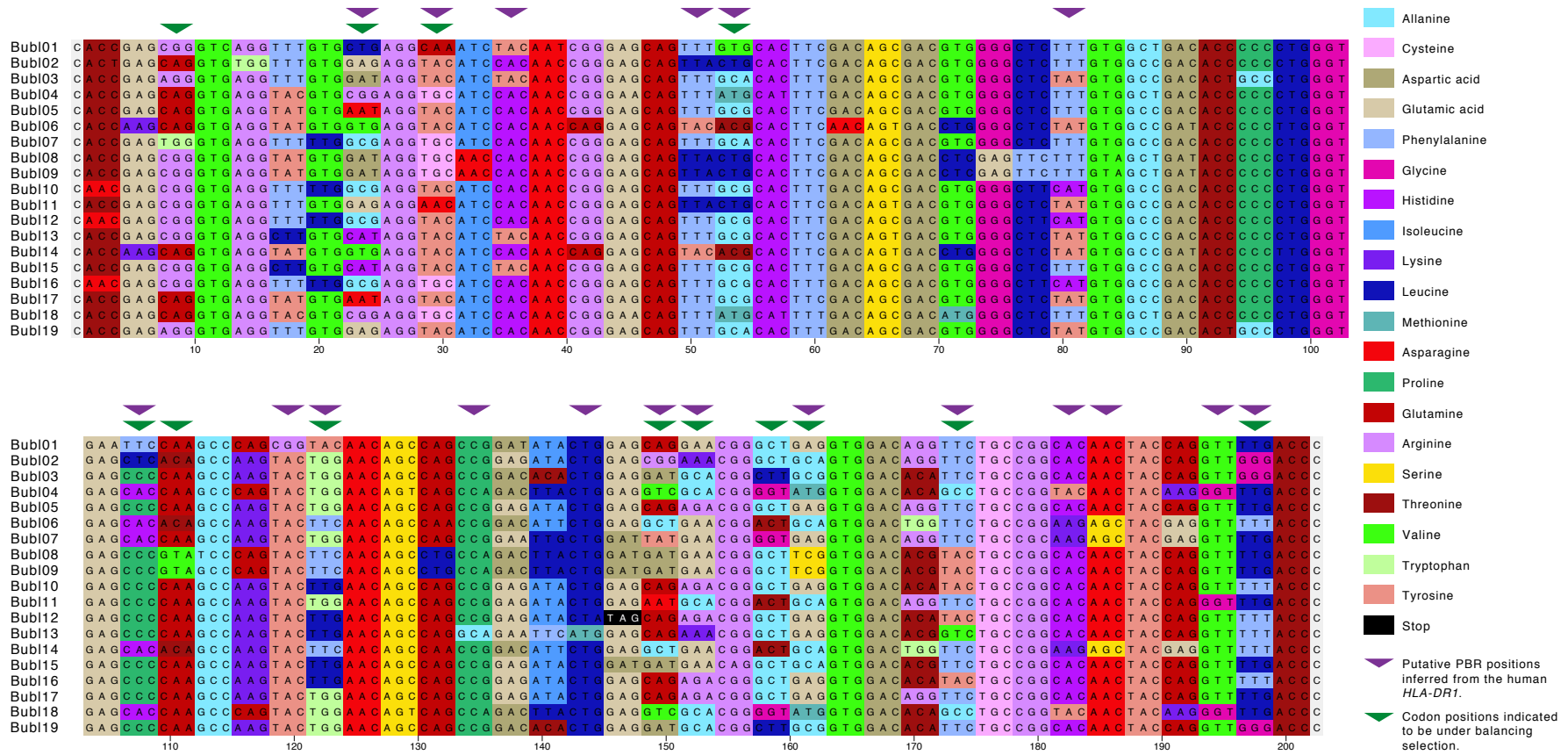

Figure S4 Alignment of nucleotide sequences of fish owl MHC class II β alleles. Codons are colored according to the amino acids they encode. Codon positions for the putative peptide binding region (PBR) inferred from the structure of the human *HLA-DR1* molecule [54] are indicated with purple arrows. Codon positions indicated by the omegaMap analysis to be under balancing selection from are indicated with green arrows. The figure was created with the Chromaseq package version 1.12 in Mesquite 3.01 (Available from <http://mesquiteproject.org/packages/chromaseq/manual/index.html/>).

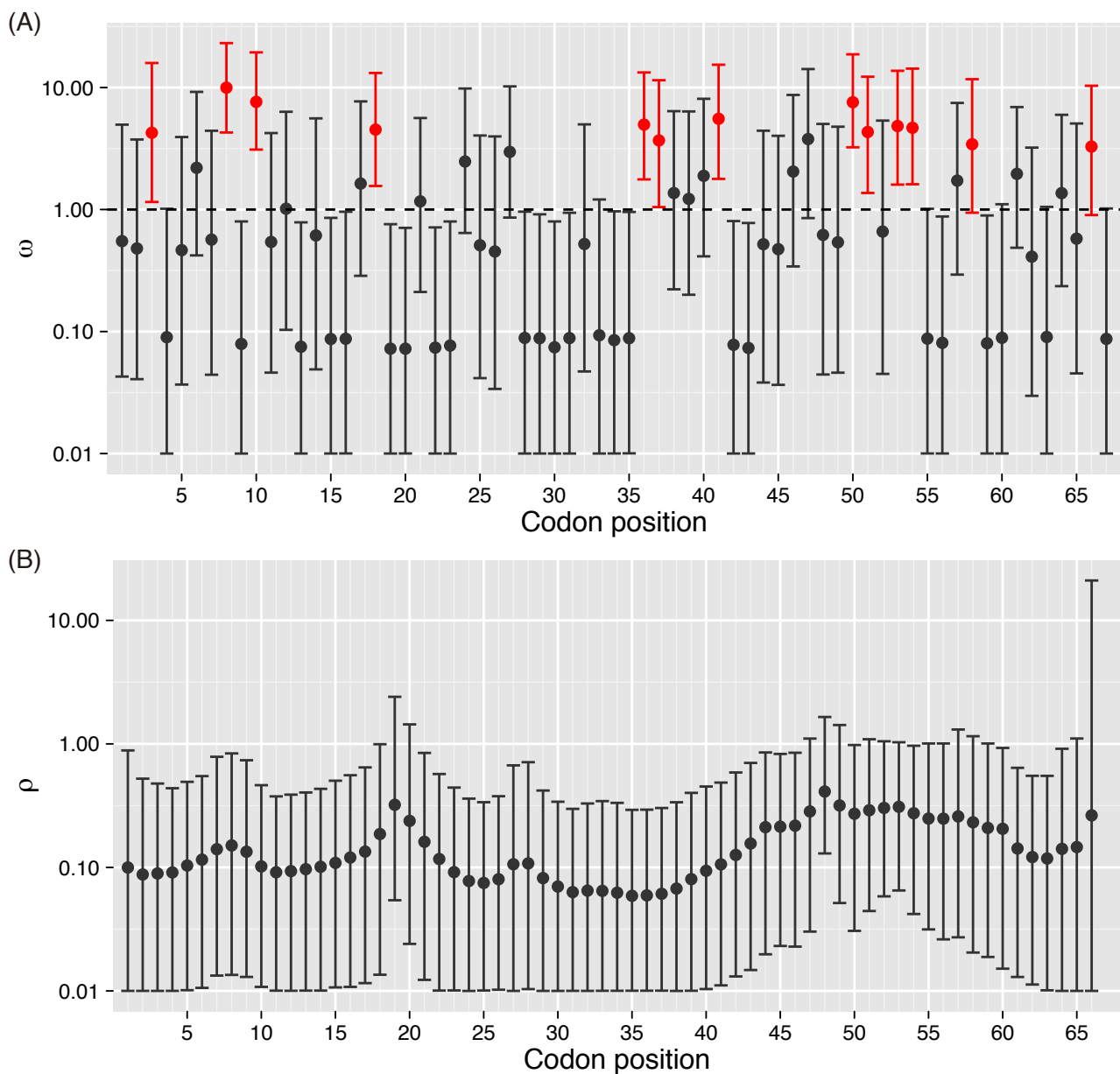

Figure S5 Variation in the d_N/d_S ratio ($= \omega$) (A) and recombination rate ($= \rho$) (B) along the MHC class IIB exon 2 of the fish owl, generated with omegaMap. Error bars indicate 95% highest posterior density intervals. Codon positions indicated to be under balancing selection (the posterior probability for $\omega > 1$ exceeds 0.95) are colored red.