

Dataset S2 – table of contents

<u>Page</u>	<u>Description</u>
2.....	File legend
3-312.....	Gene trees
313-388.....	Supporting information for gene trees
389-391.....	Supporting information for genomic PCR (Figure 2)

Dataset S2. Gene trees and genomic PCR associated information. Gene trees for a given gene presented with Bayesian (top) and bootstrap (500) support (lower). Gene tree information includes the gene identifier for a given tardigrade gene, NCBI accession number and taxon label in each tree for genes used in our alignments. Pertinent information for each genomic PCR.

Gene trees

Key:

Met = metazoan

Pla = plant

Fun = fungi

Pro = protist

Arc = archaea

Eub = eubacteria

H_duj = *Hypsibius dujardini* (tardigrade)

snap_masked_scaffold16703_size5213_processed_gene_0.5
 chromosomal replication initiator protein DnaA

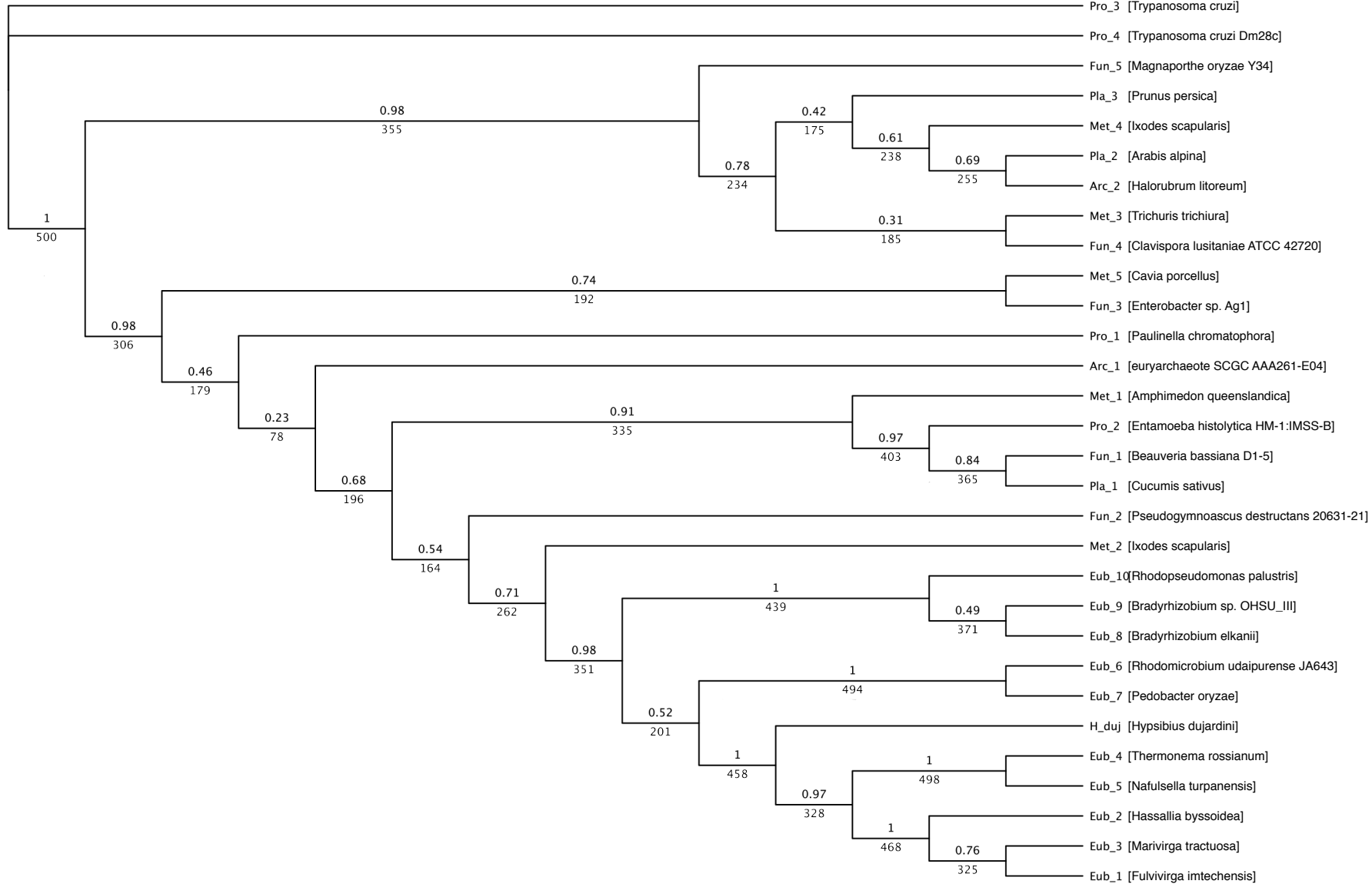

snap_masked_scaffold21250_size3389_processed_gene_0.4
Fis family transcriptional regulator

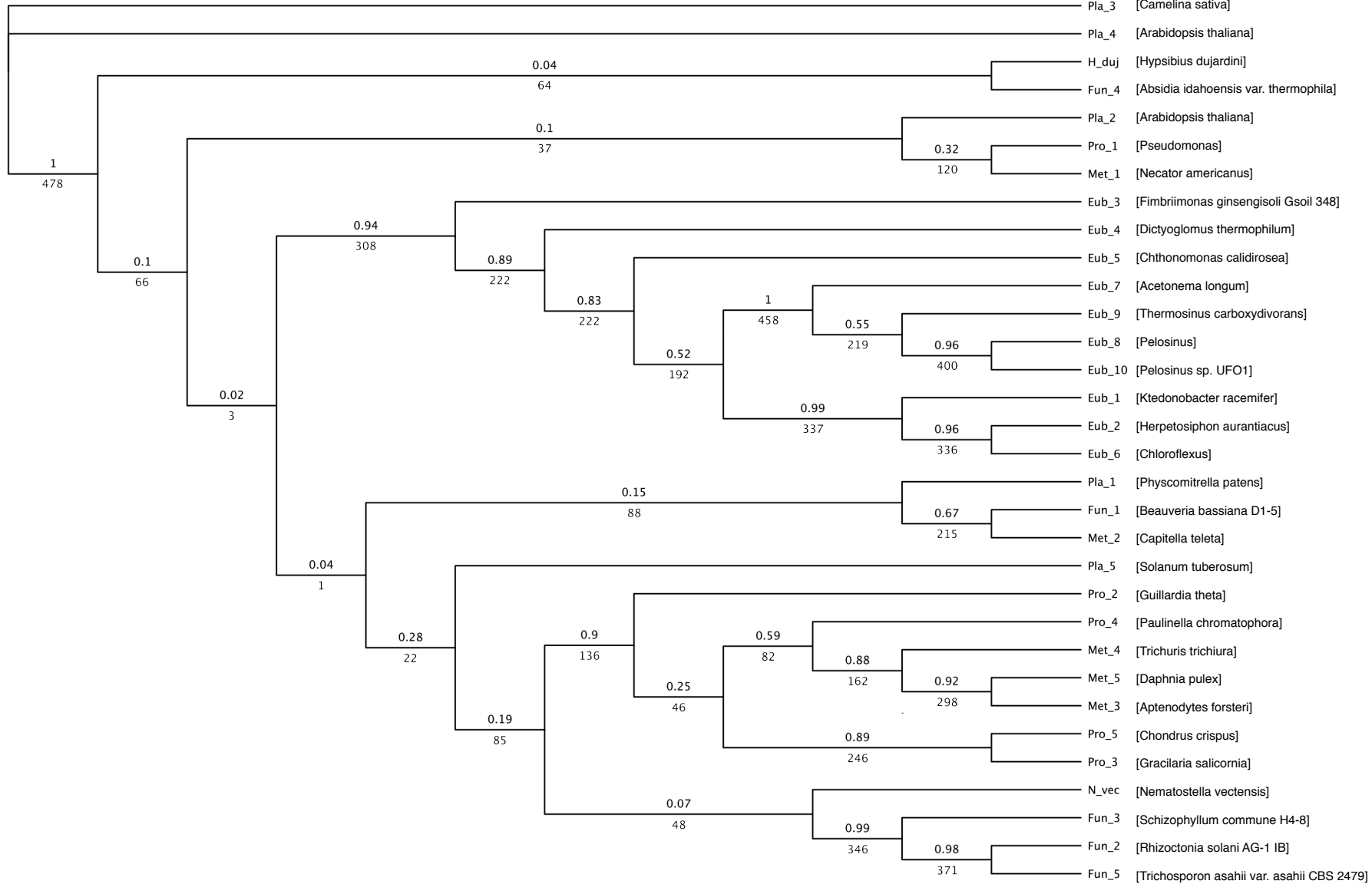

snap_masked_scaffold15974_size5576_processed_gene_0.4
 Integrase

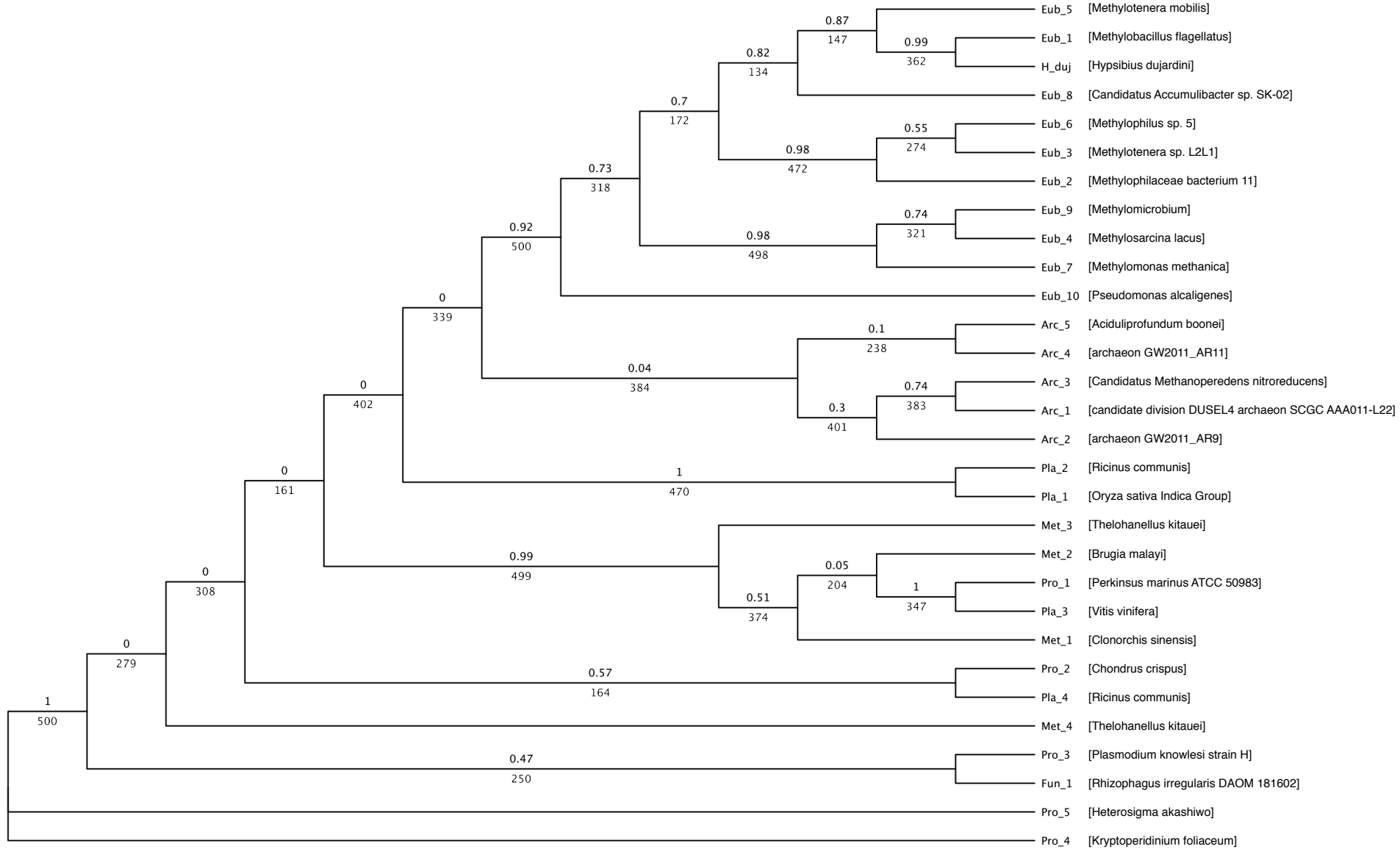

snap_masked_scaffold15732_size5688_processed_gene_0.5
 glutamate--cysteine ligase

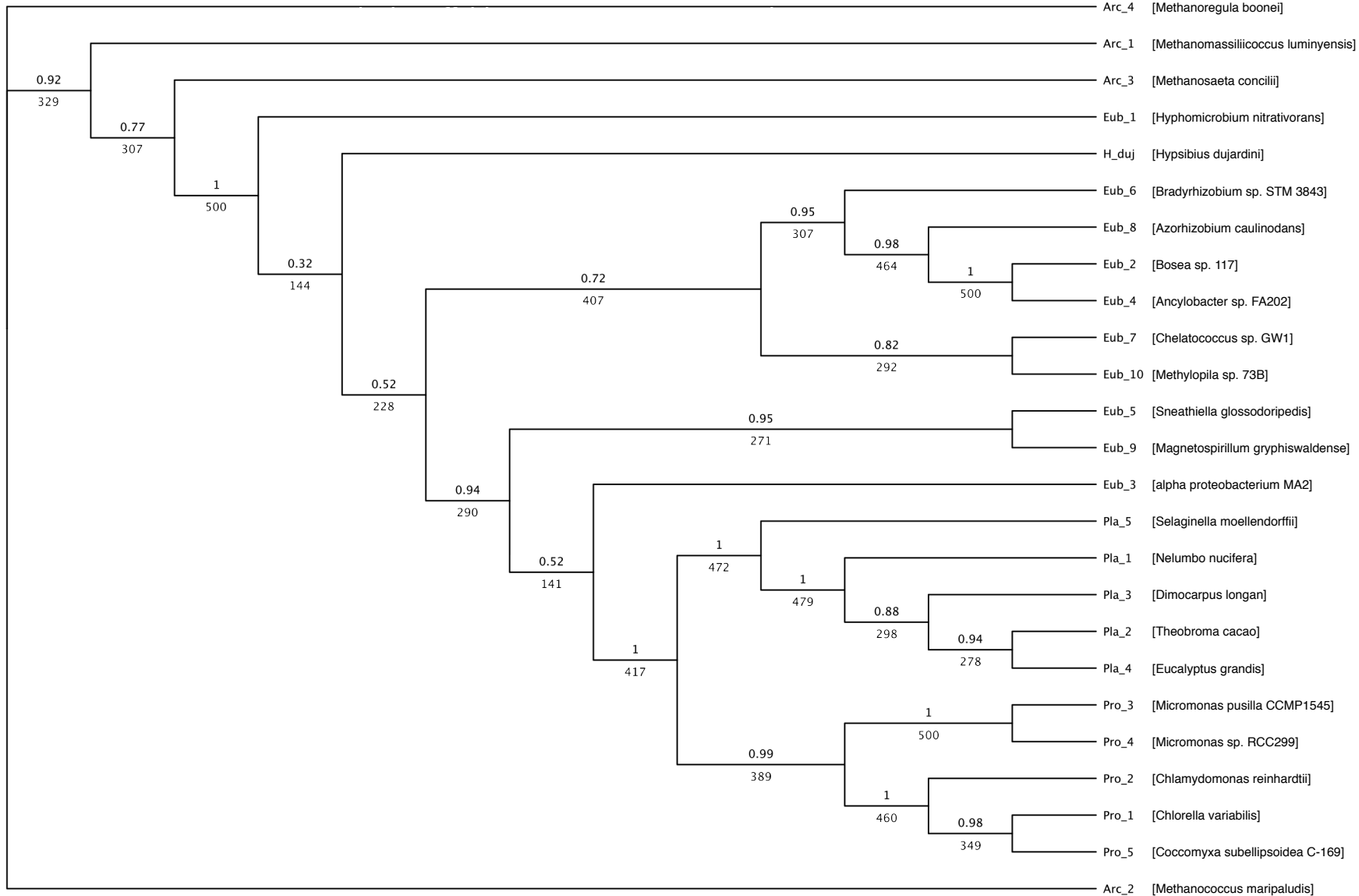

snap_masked_scaffold11172_size8401_processed_gene_0.10

Acetyl-CoA acetyltransferase

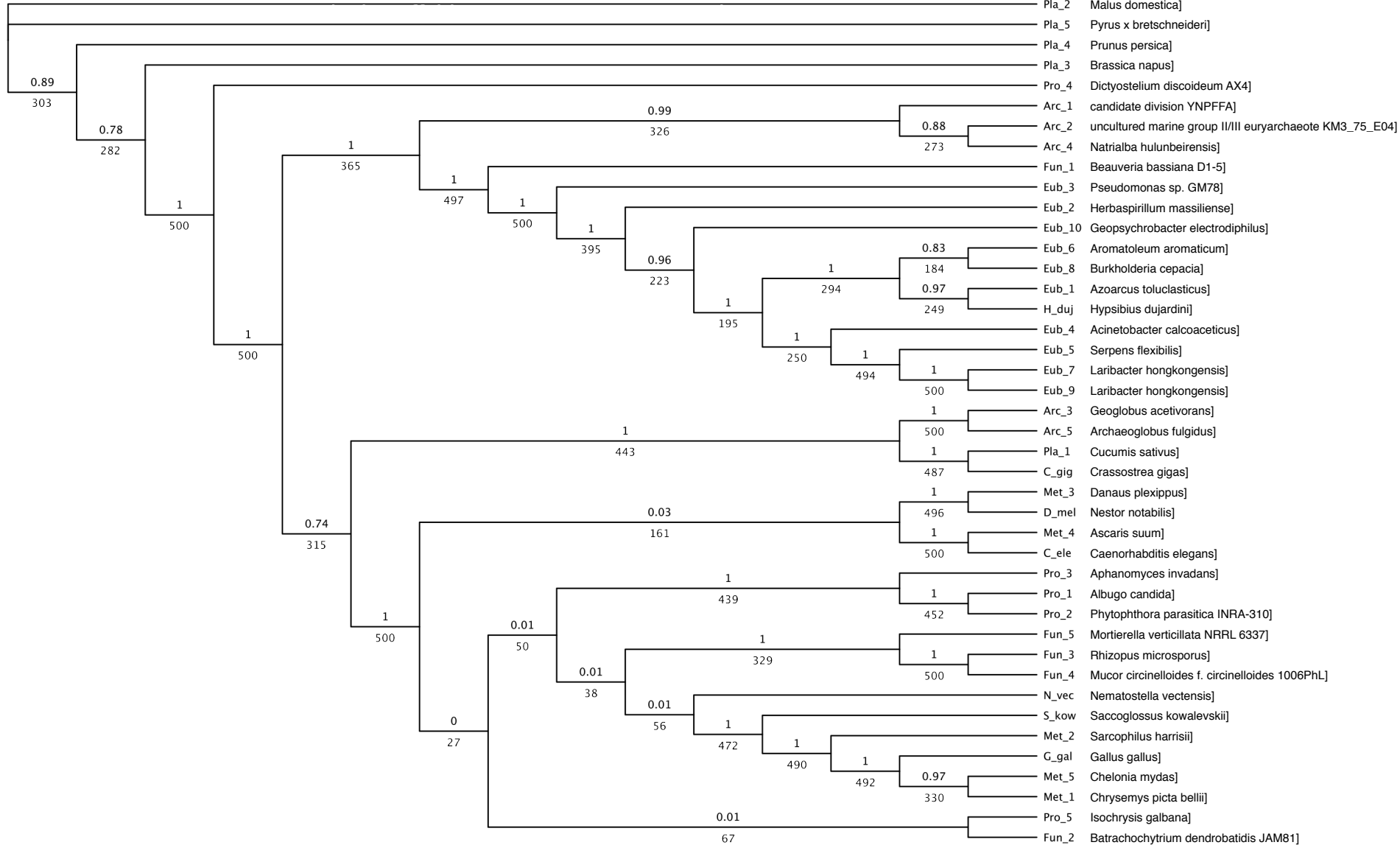

snap_masked_scaffold10640_size8688_processed_gene_0.5
 hypothetical protein HGMM_F07E12C19

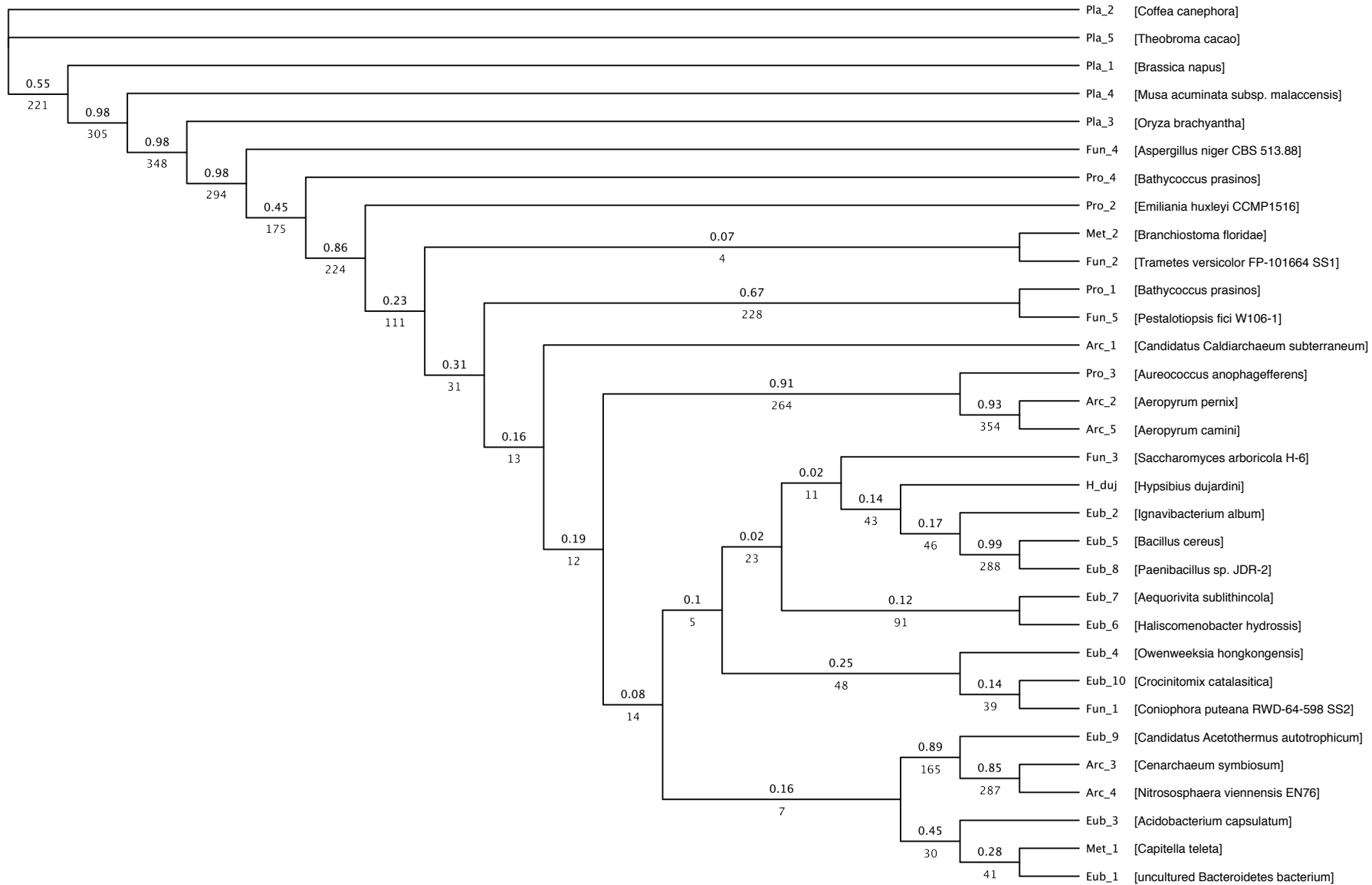

snap_masked_scaffold10032_size9031_processed_gene_0.5
 RNA 2'-phosphotransferase

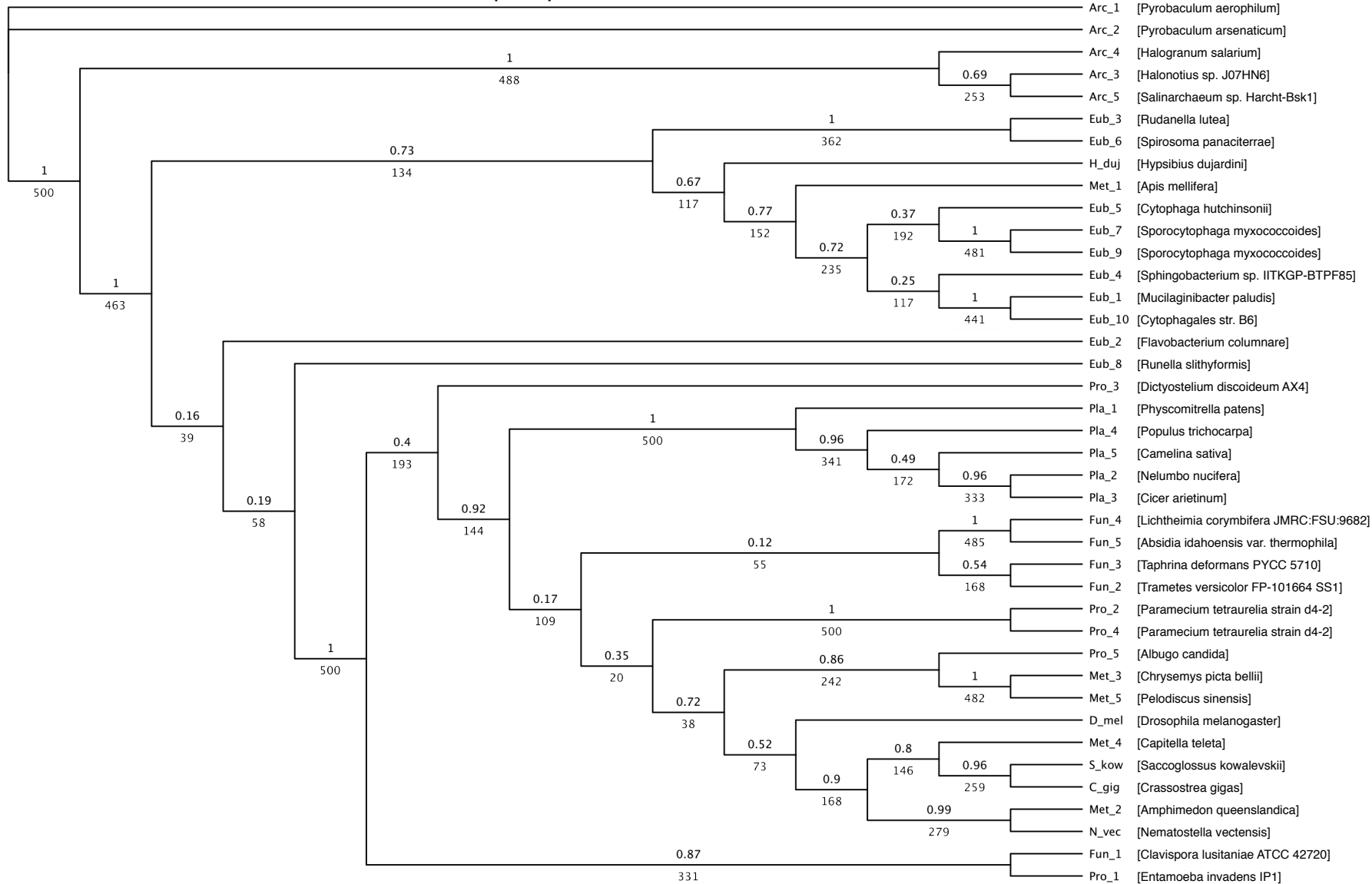

snap_masked_scaffold10028_size9034_processed_gene_0.14
hypothetical protein BW41_02662

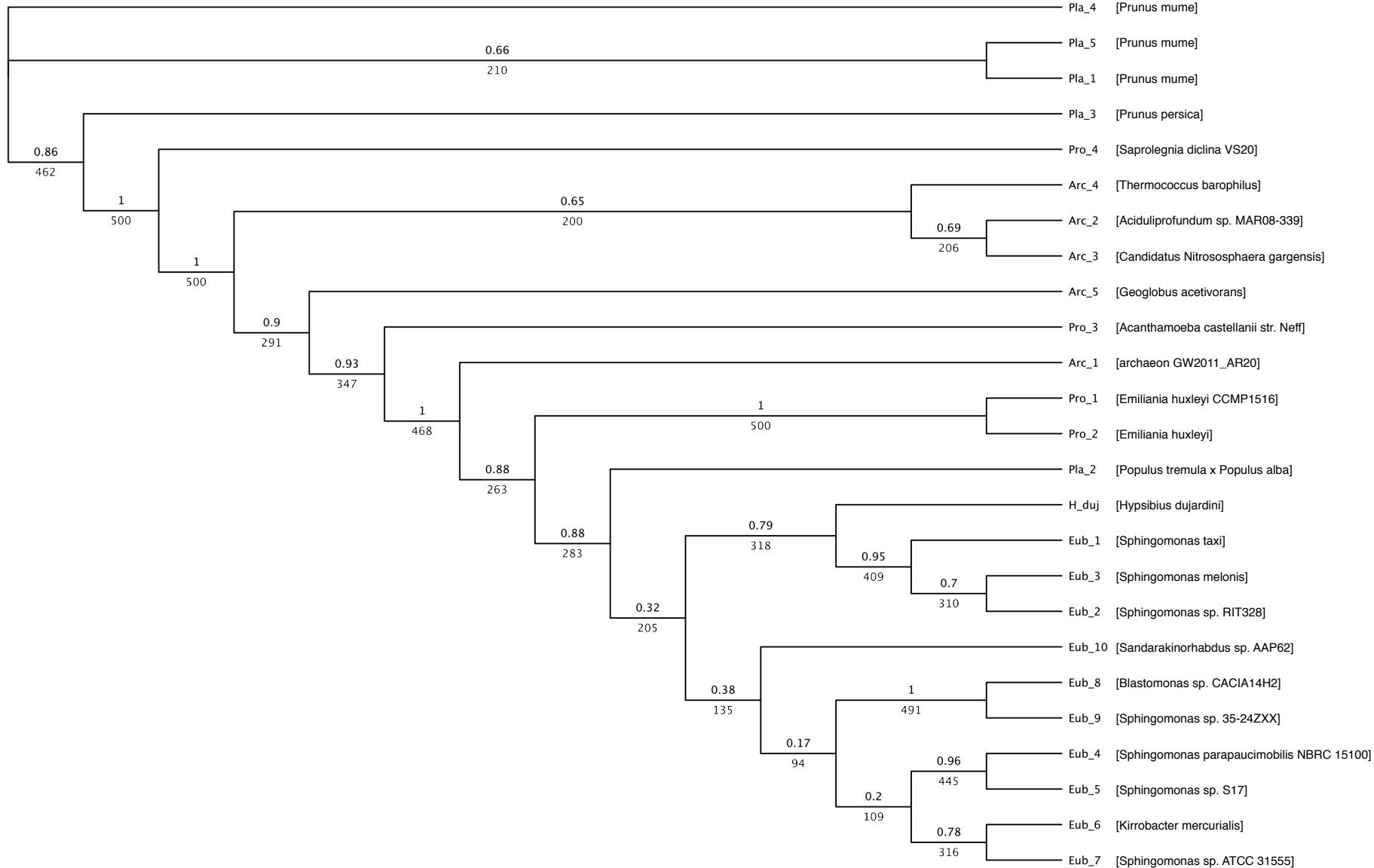

snap_masked_scaffold10028_size9034_processed_gene_0.12
 LysR family transcriptional regulator

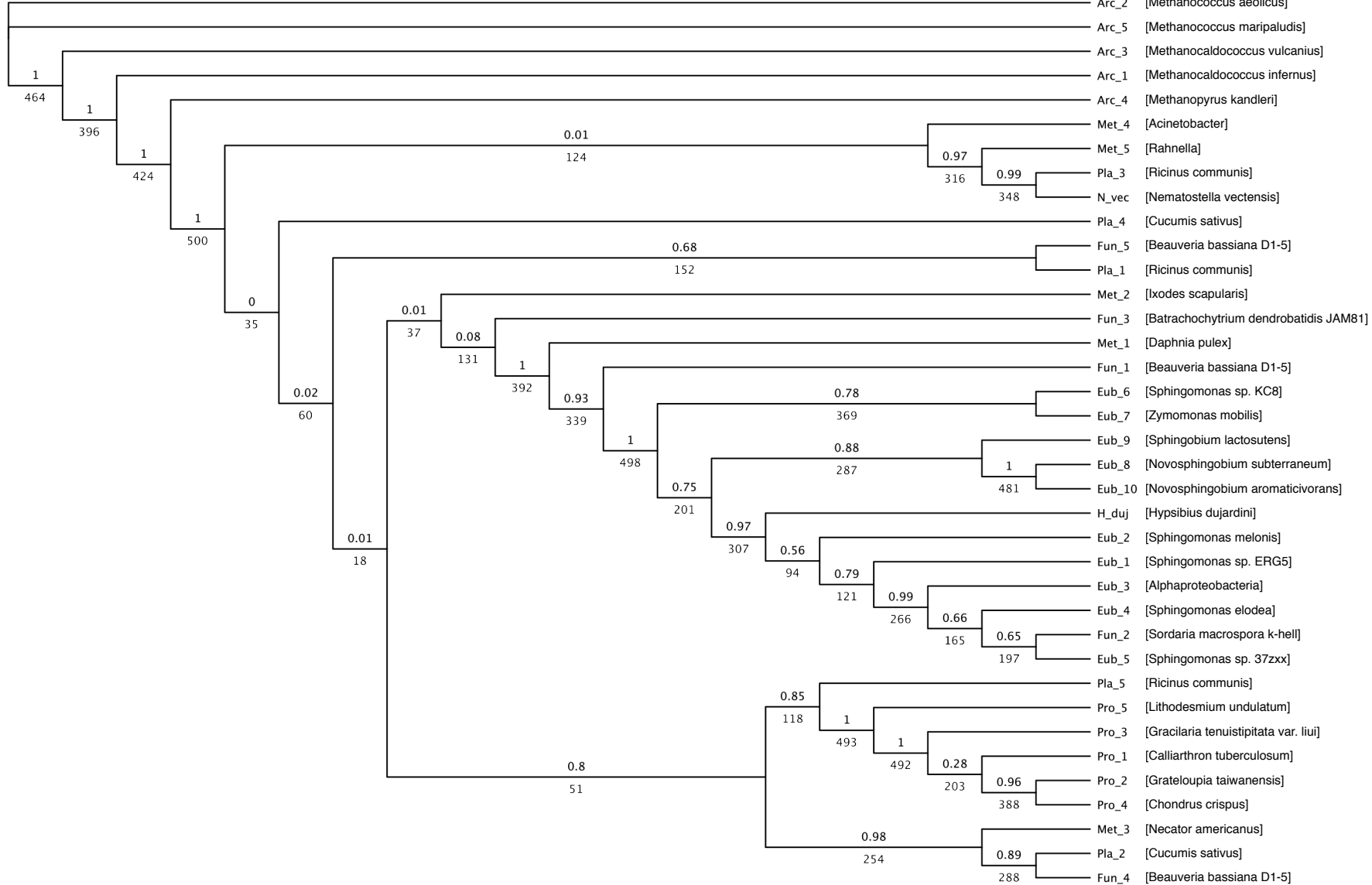

snap_masked_scaffold9447_processed_gene_0.6
aldehyde dehydrogenase

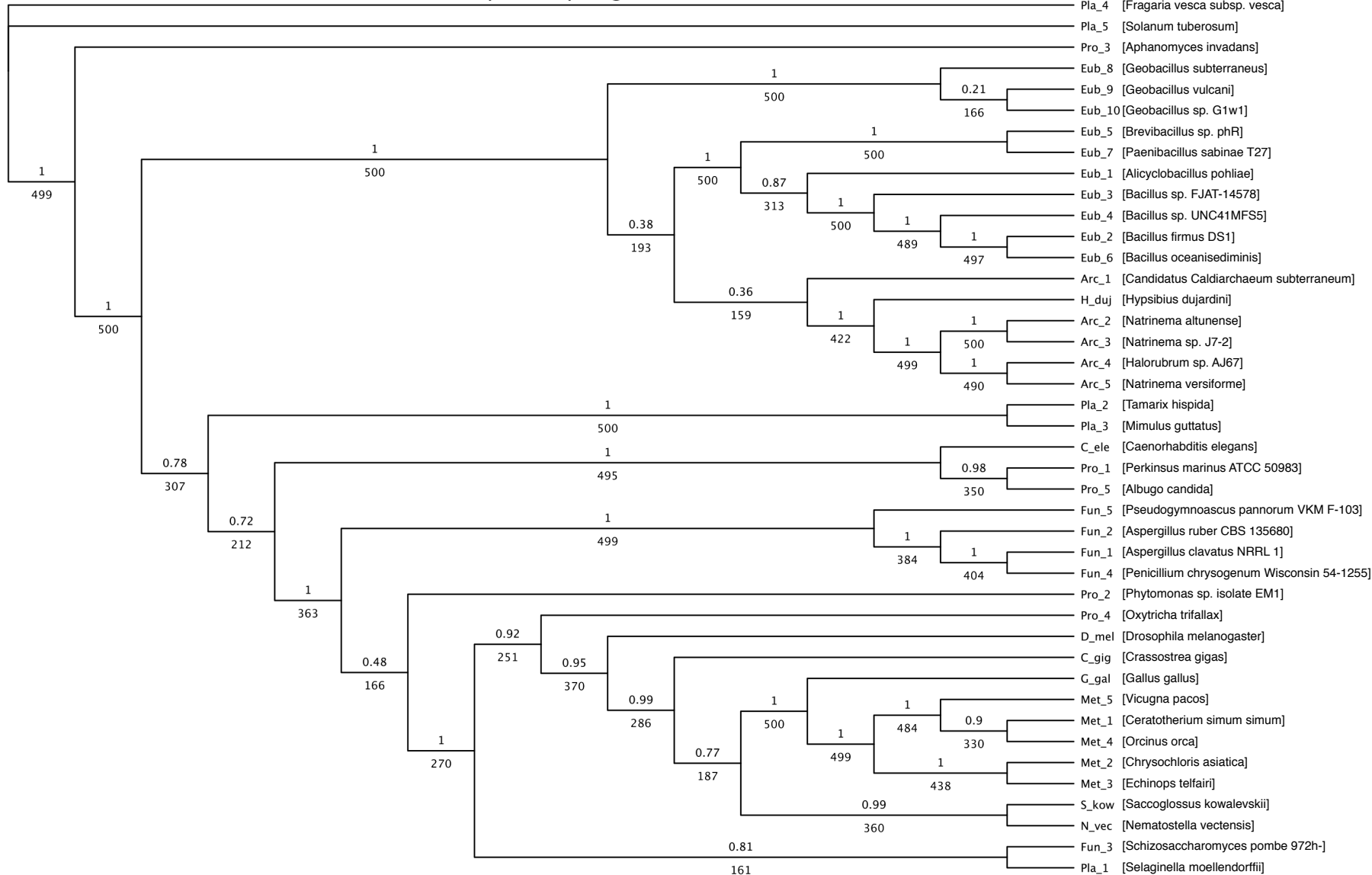

snap_masked_scaffold9056_size9691_processed_gene_0.3
 hypothetical protein ACD_44C00357G0002

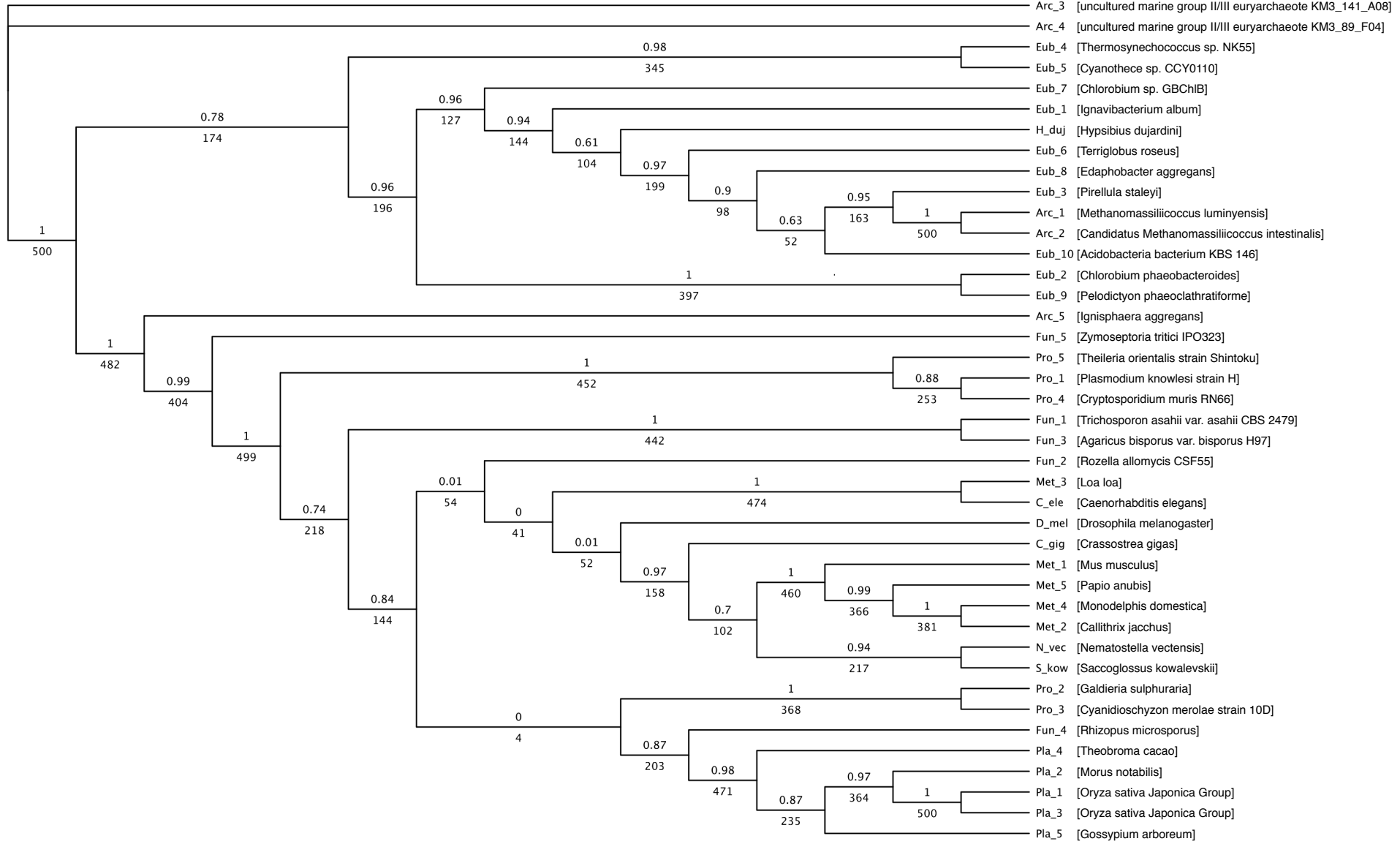

snap_masked_scaffold8624_processed_gene_0.6
short-chain dehydrogenase

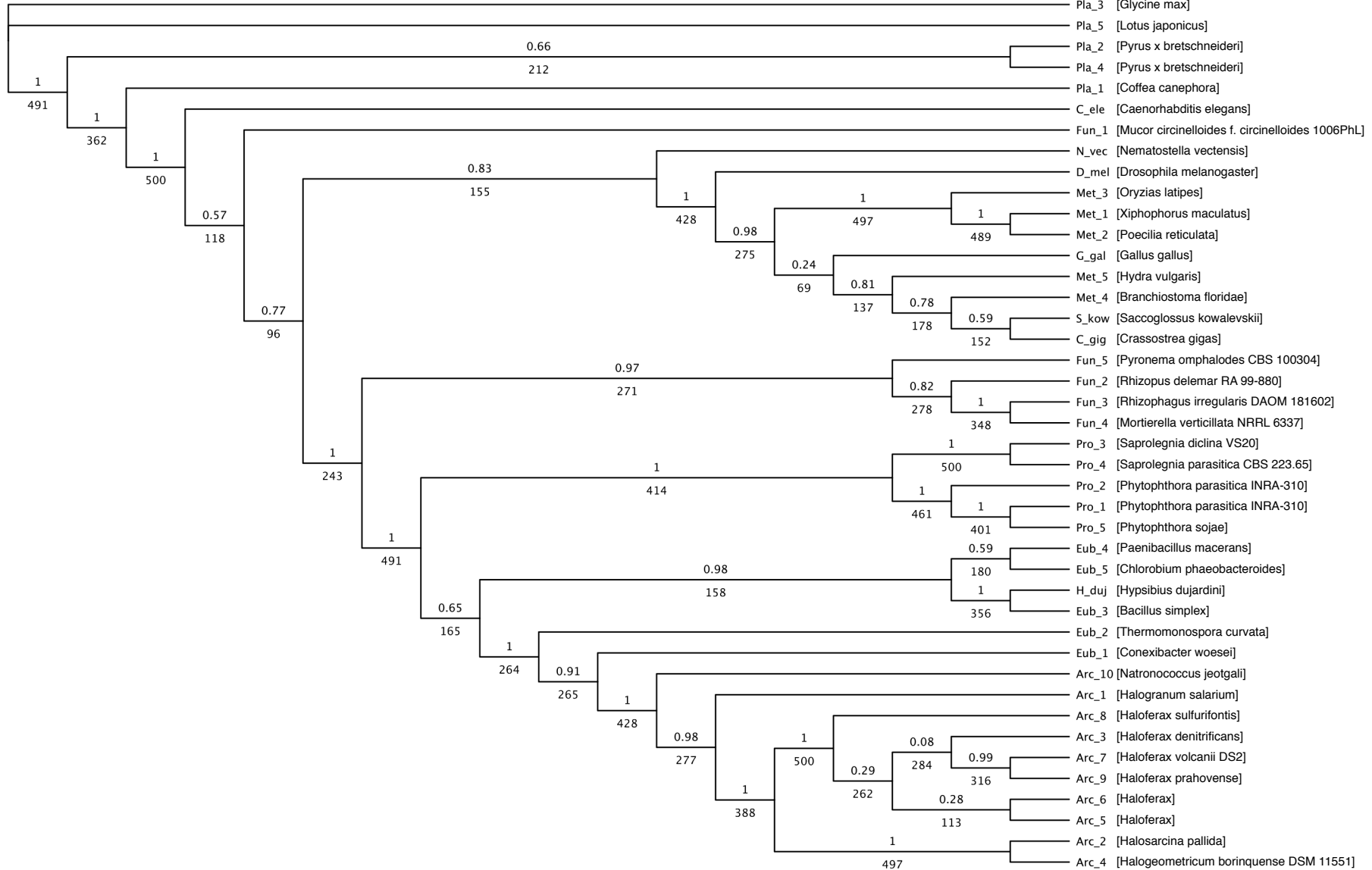

snap_masked_scaffold8578_size10052_processed_gene_0.10
 polysaccharide biosynthesis protein CapD

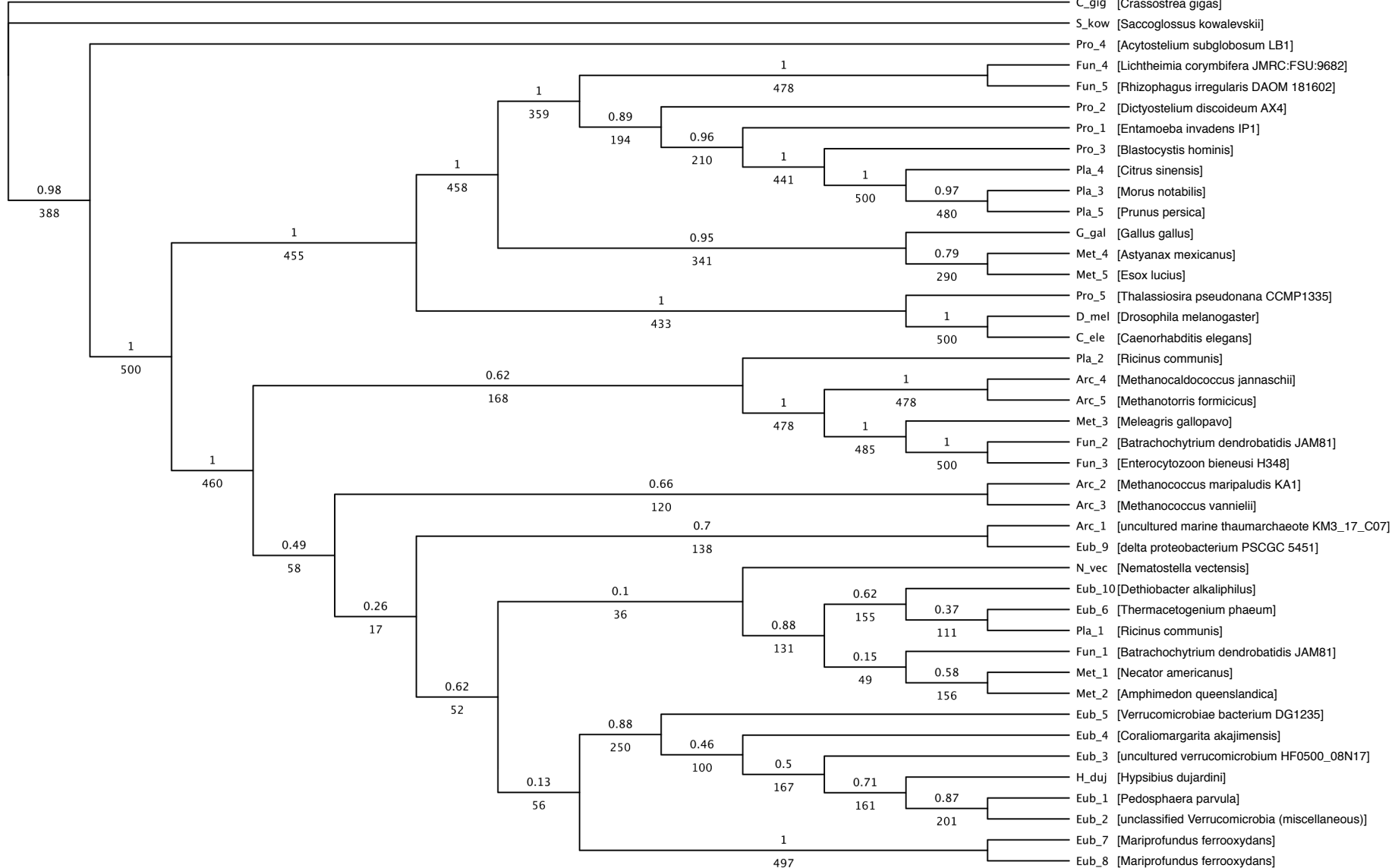

recombinase RecR

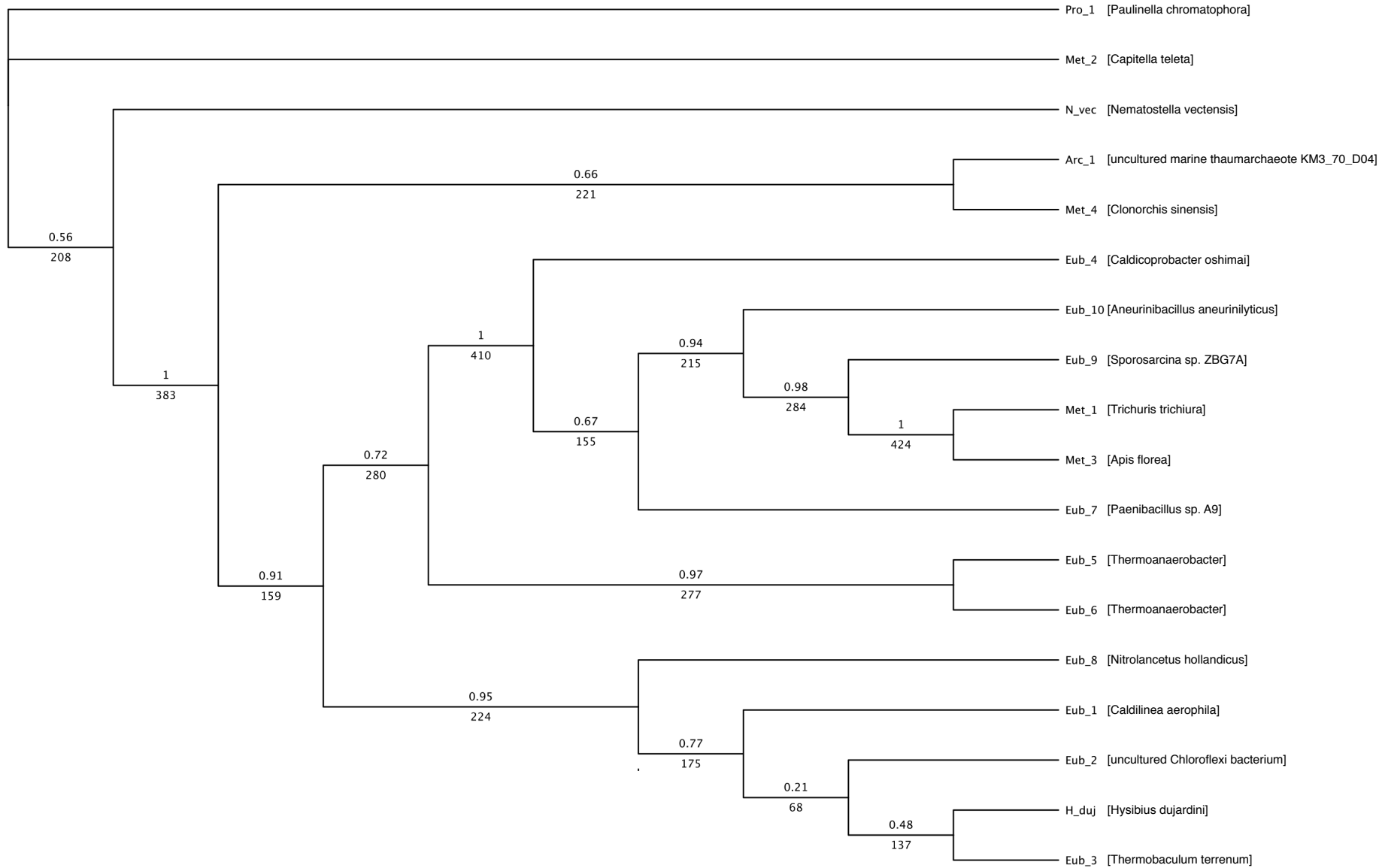

snap_masked_scaffold5501_size13528_processed_gene_0.4

hypothetical protein

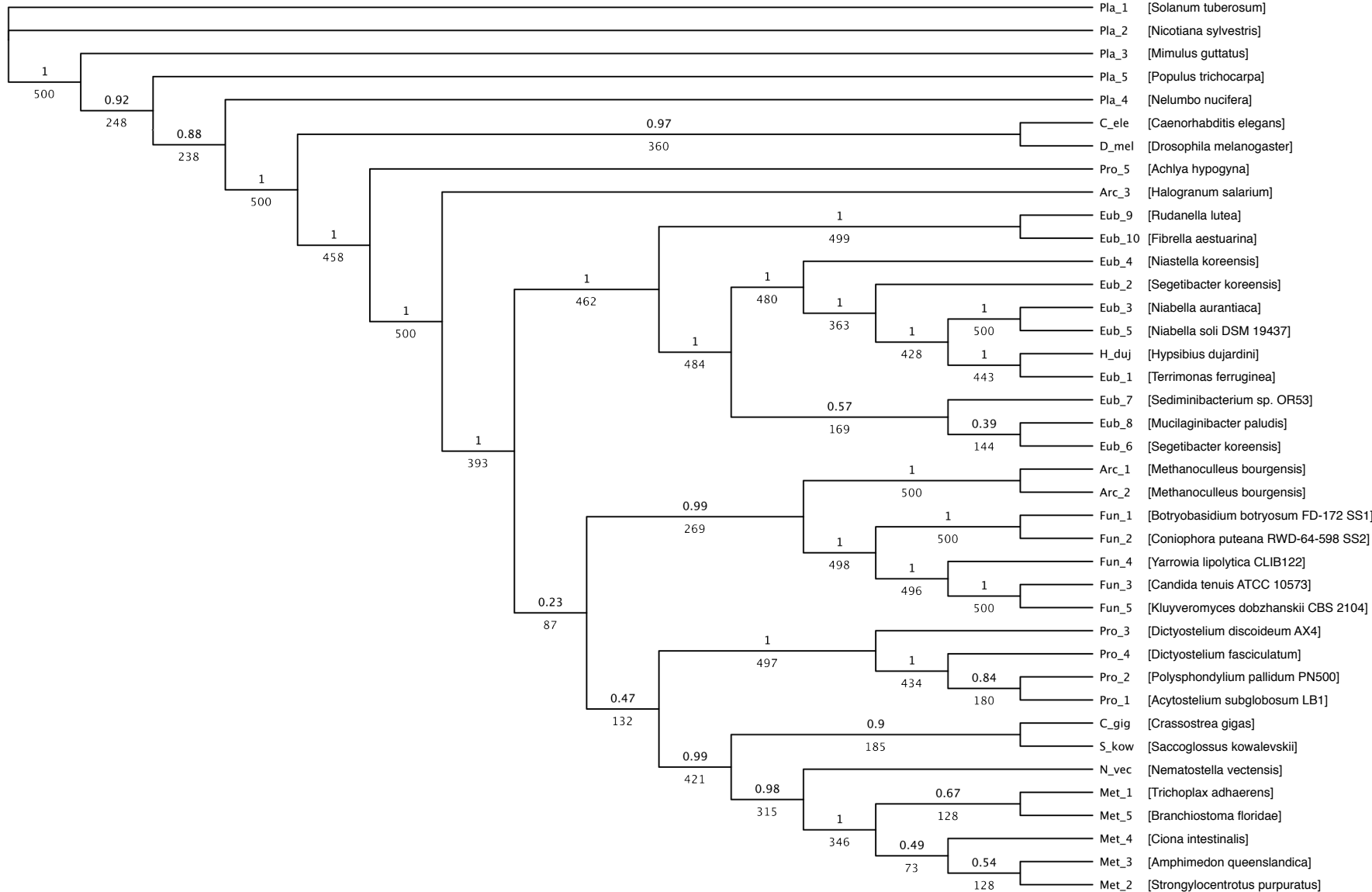

snap_masked_scaffold5085_processed_gene_0.8
RNA helicase

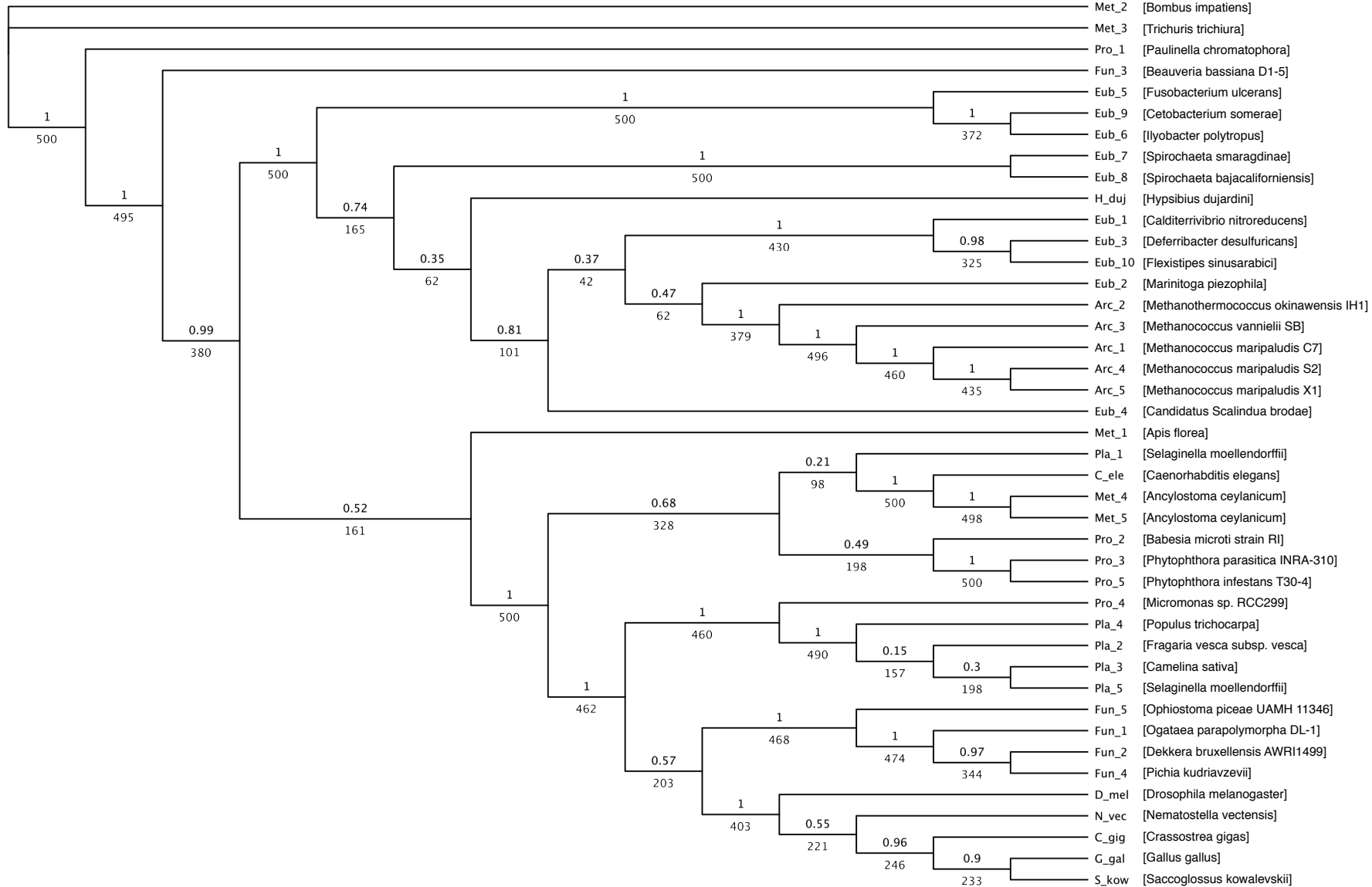

snap_masked_scaffold2358_size21708_processed_gene_0.4
hypothetical protein mv_R860

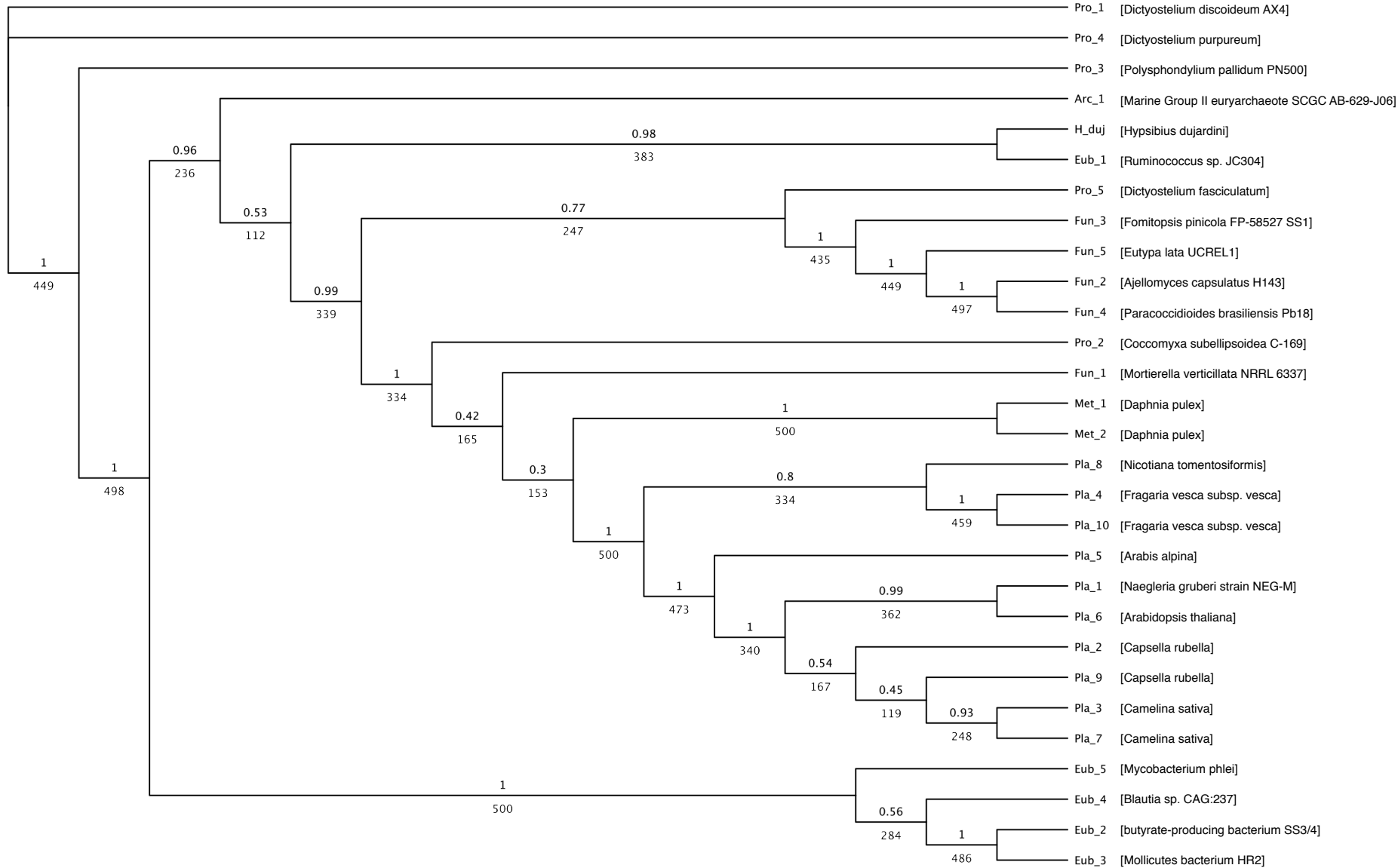

snap_masked_scaffold4718_size14934_processed_gene_0.15
preprotein translocase subunit SecY

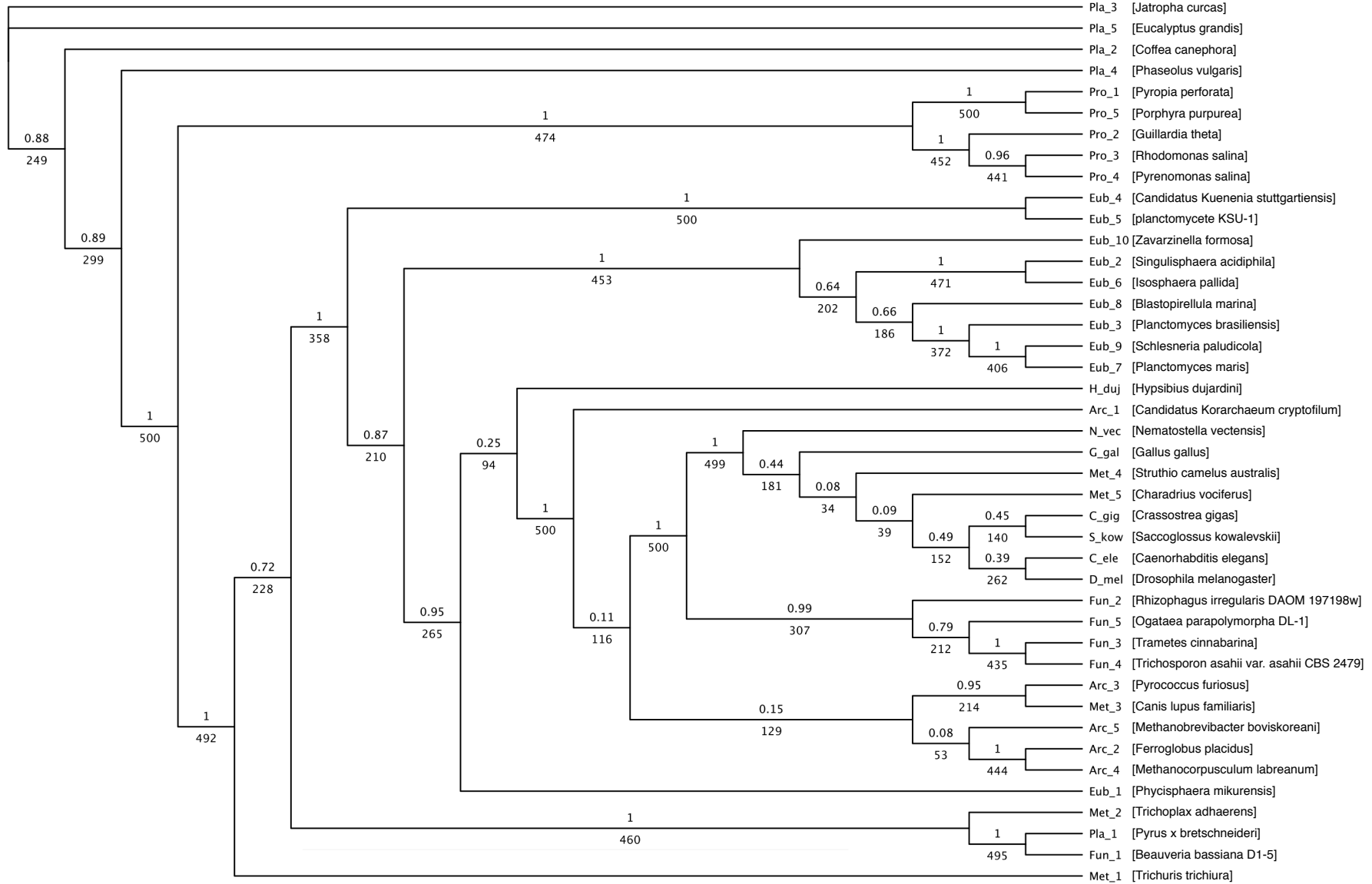

snap_masked_scaffold2280_size22025_processed_gene_0.10
NmrA family protein

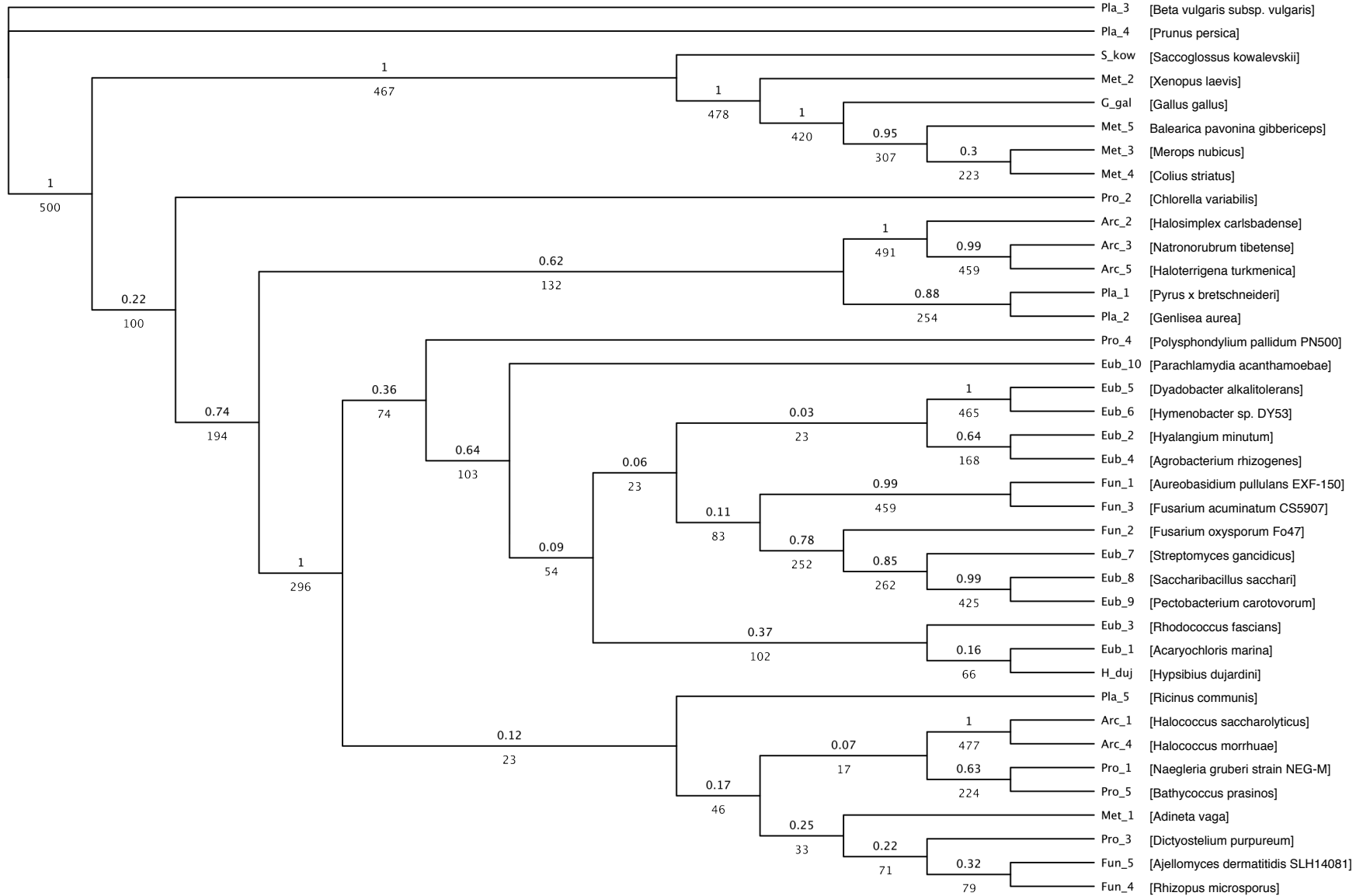

snap_masked_scaffold2263_size22100_processed_gene_0.5
alpha/beta hydrolase

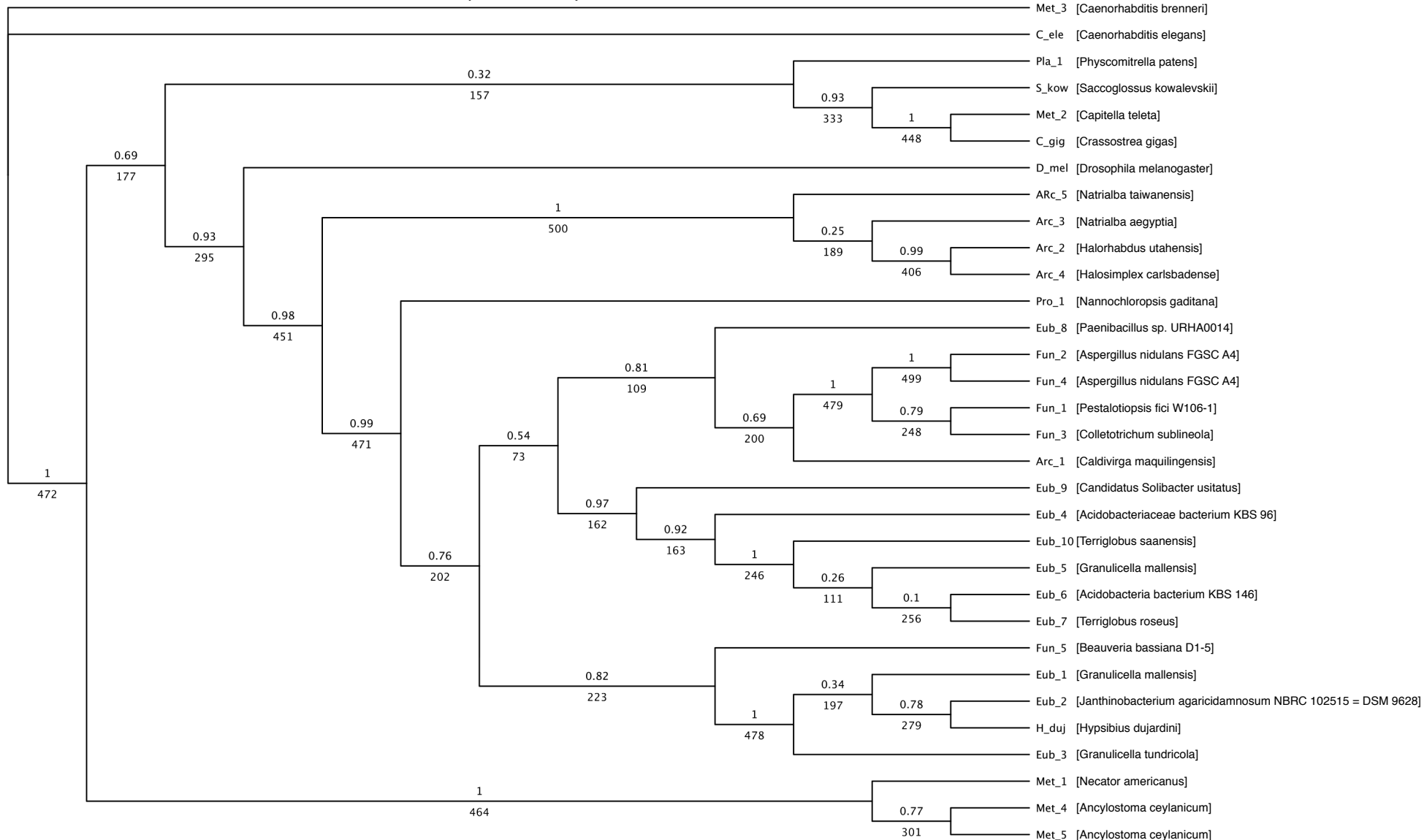

glutamyl-tRNA synthetase

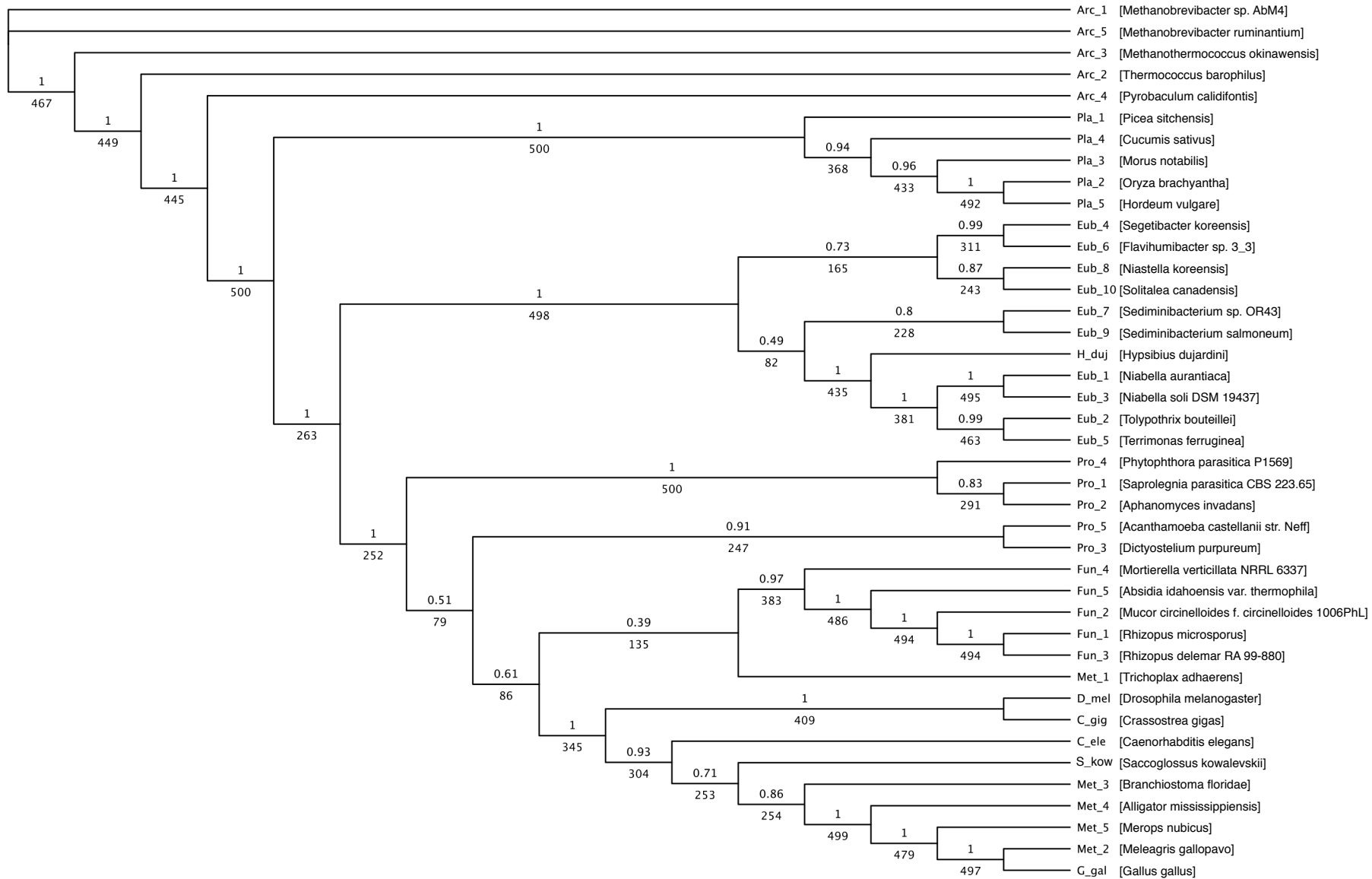

snap_masked_scaffold1340_size28252_processed_gene_0.28

short-chain dehydrogenase

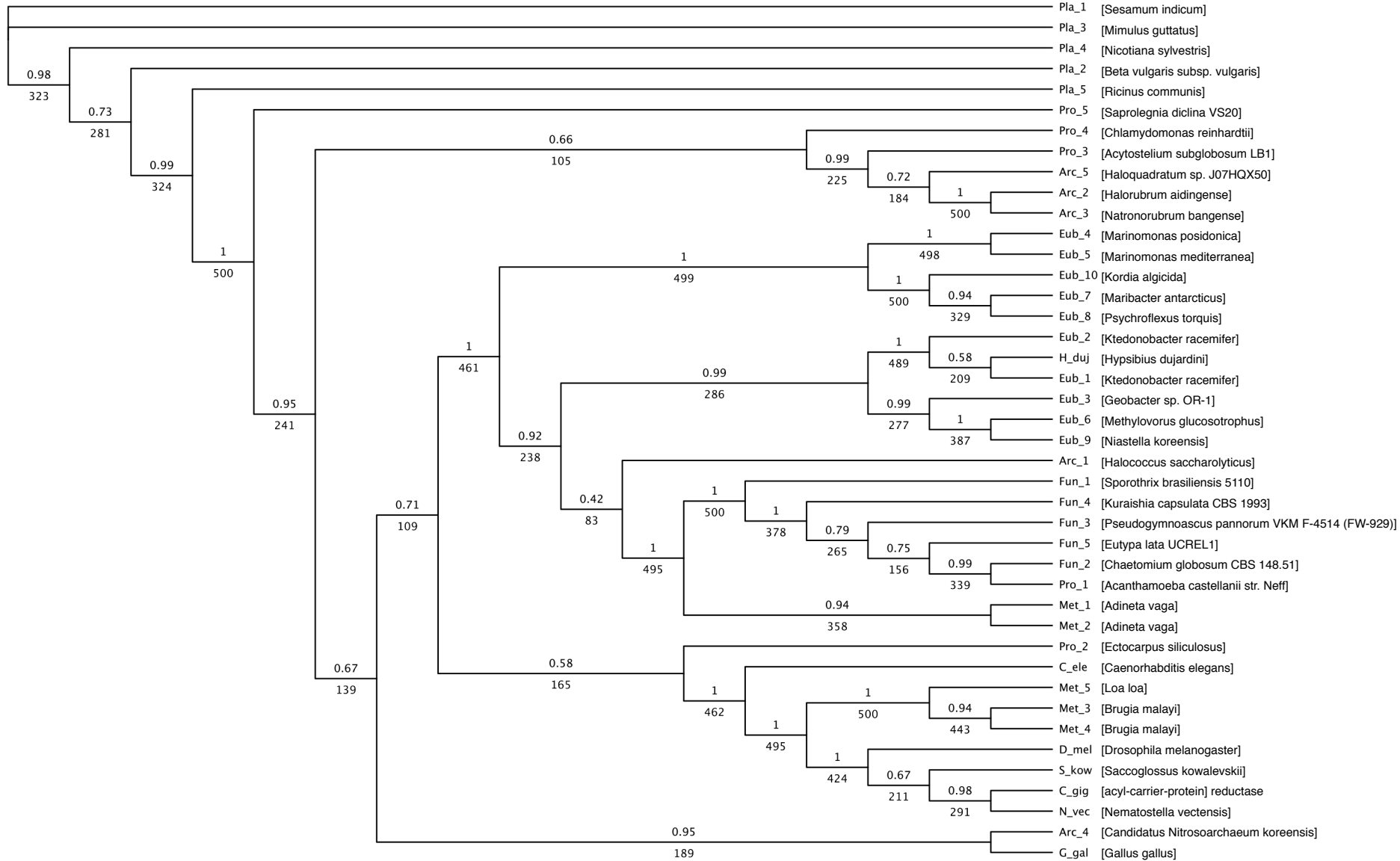

snap_masked_scaffold1229_processed_gene_0.12

including n-acetylases of ribosomal protein

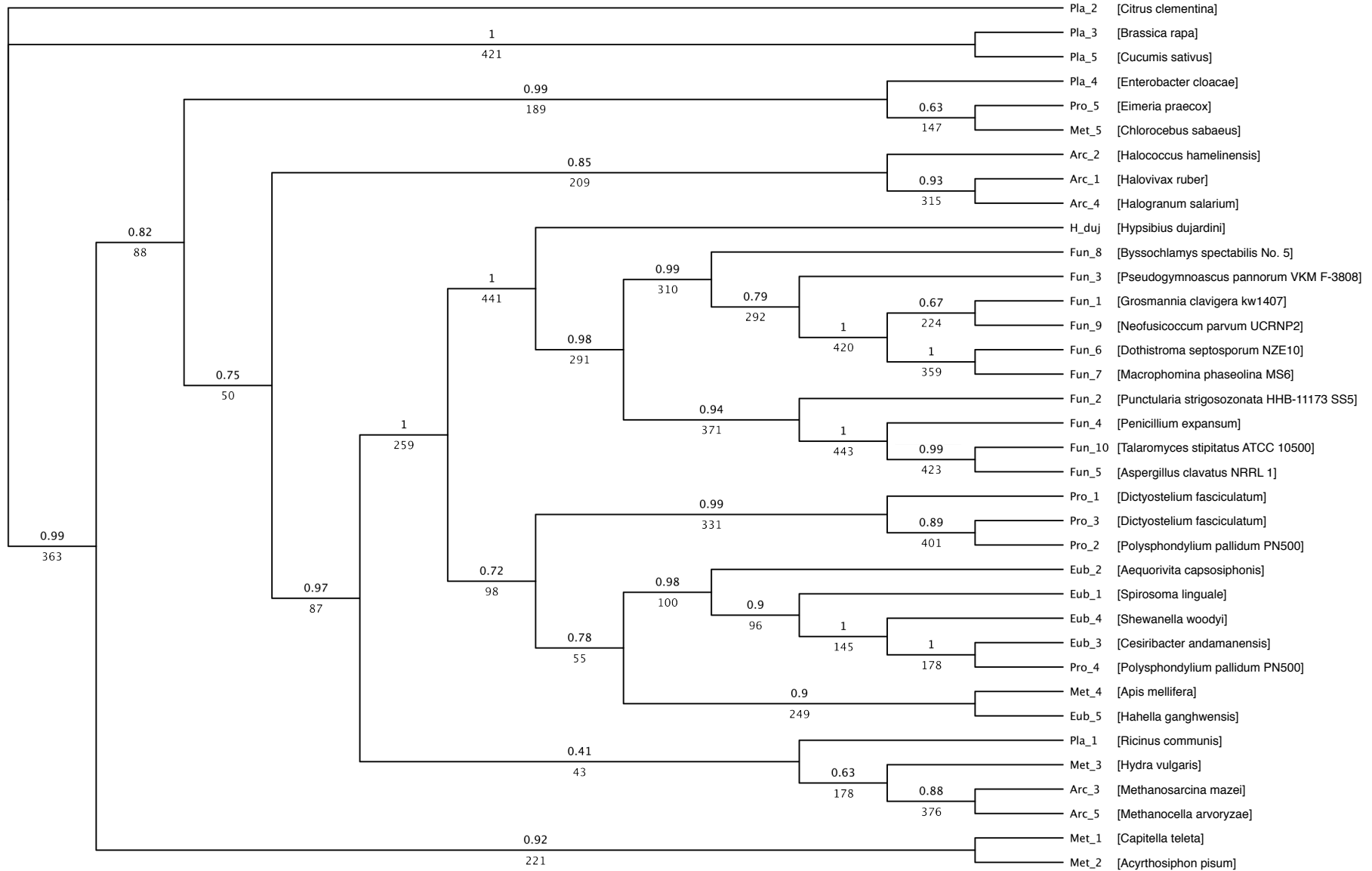

snap_masked_scaffold1017_size31835_processed_gene_0.17
deoxycytidine triphosphate deaminase

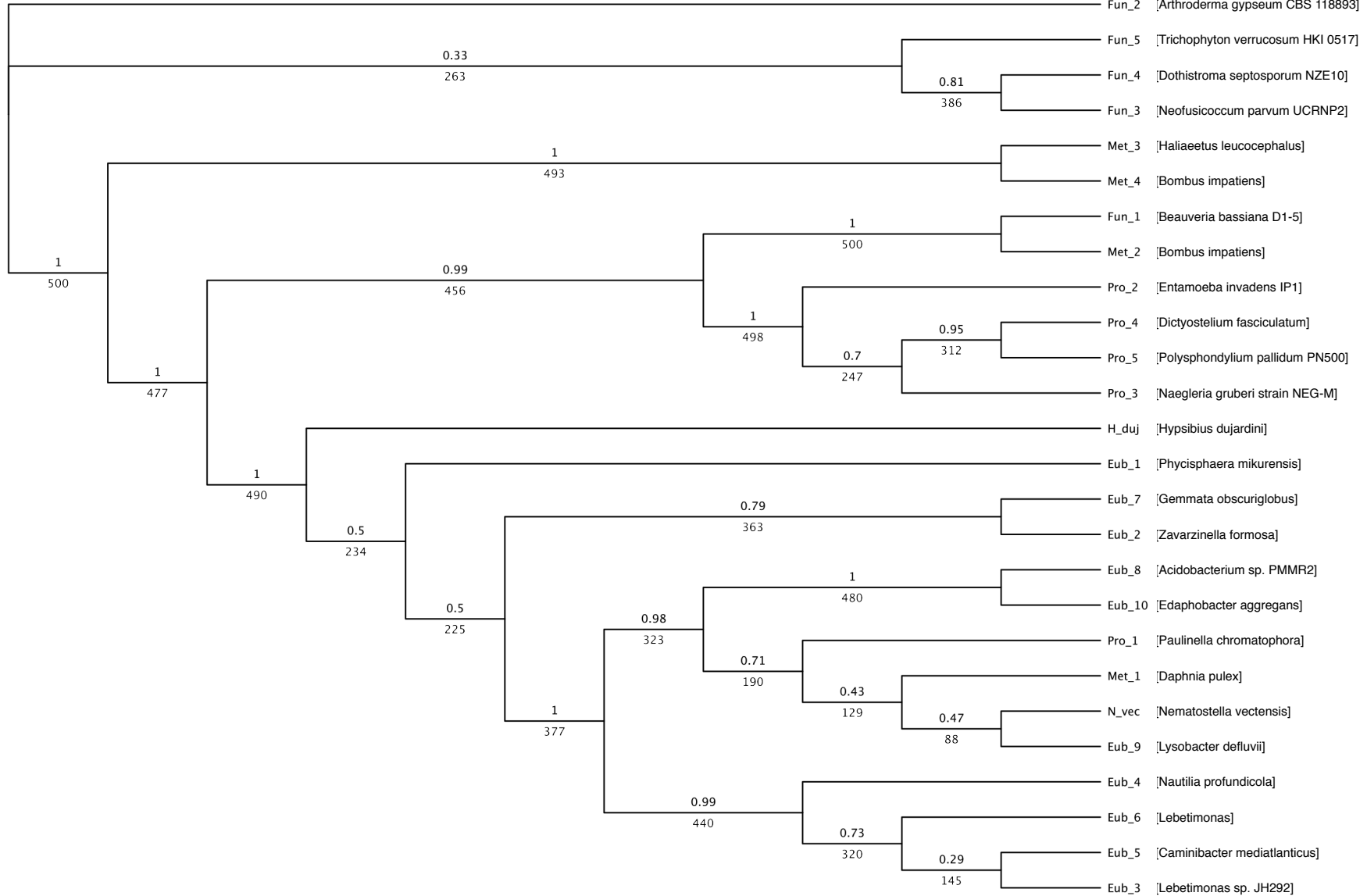

snap_masked_scaffold878_size33947_processed_gene_0.18

3-oxoacyl-ACP reductase

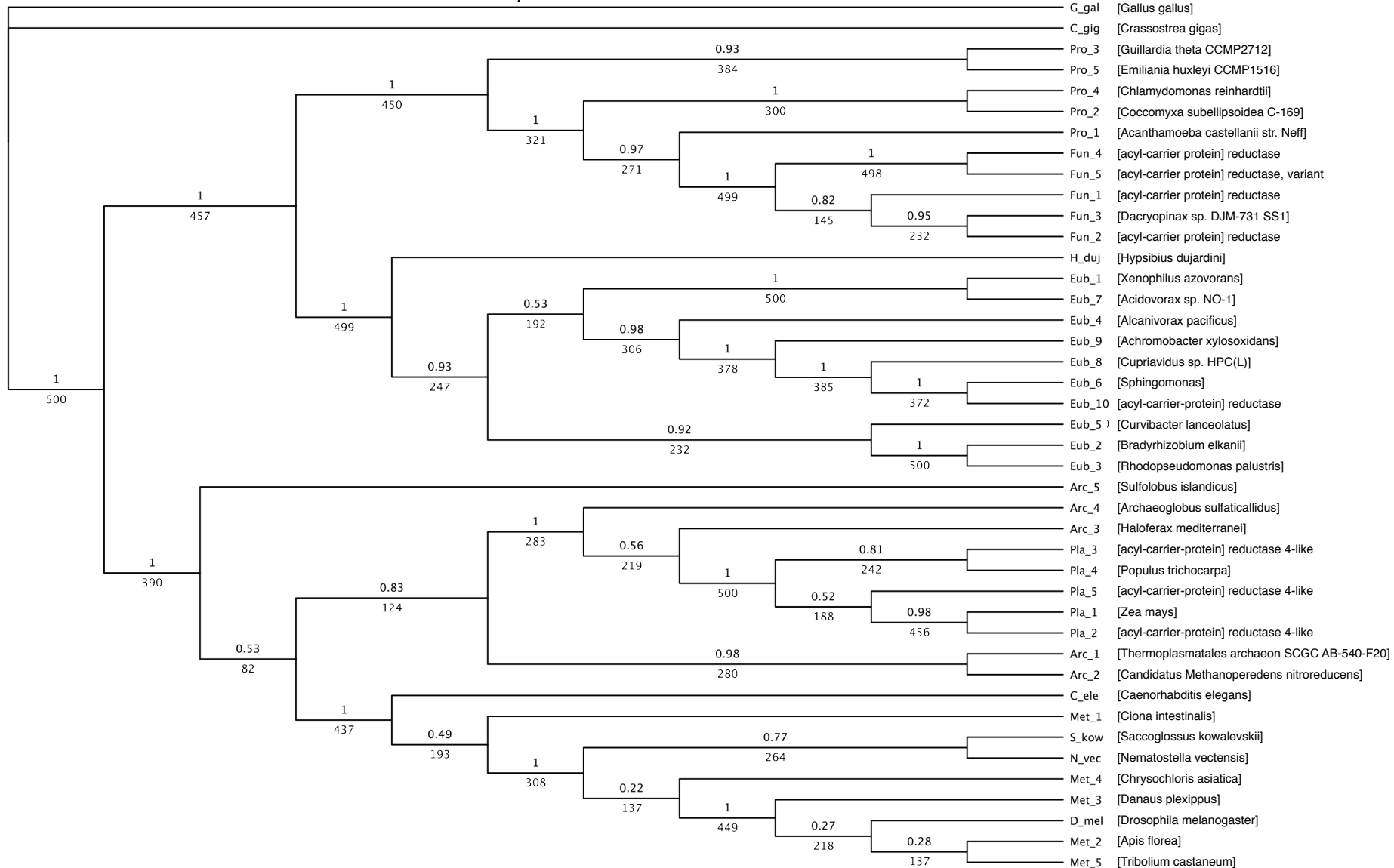

snap_masked_scaffold815_size34909_processed_gene_0.7

NmrA family protein

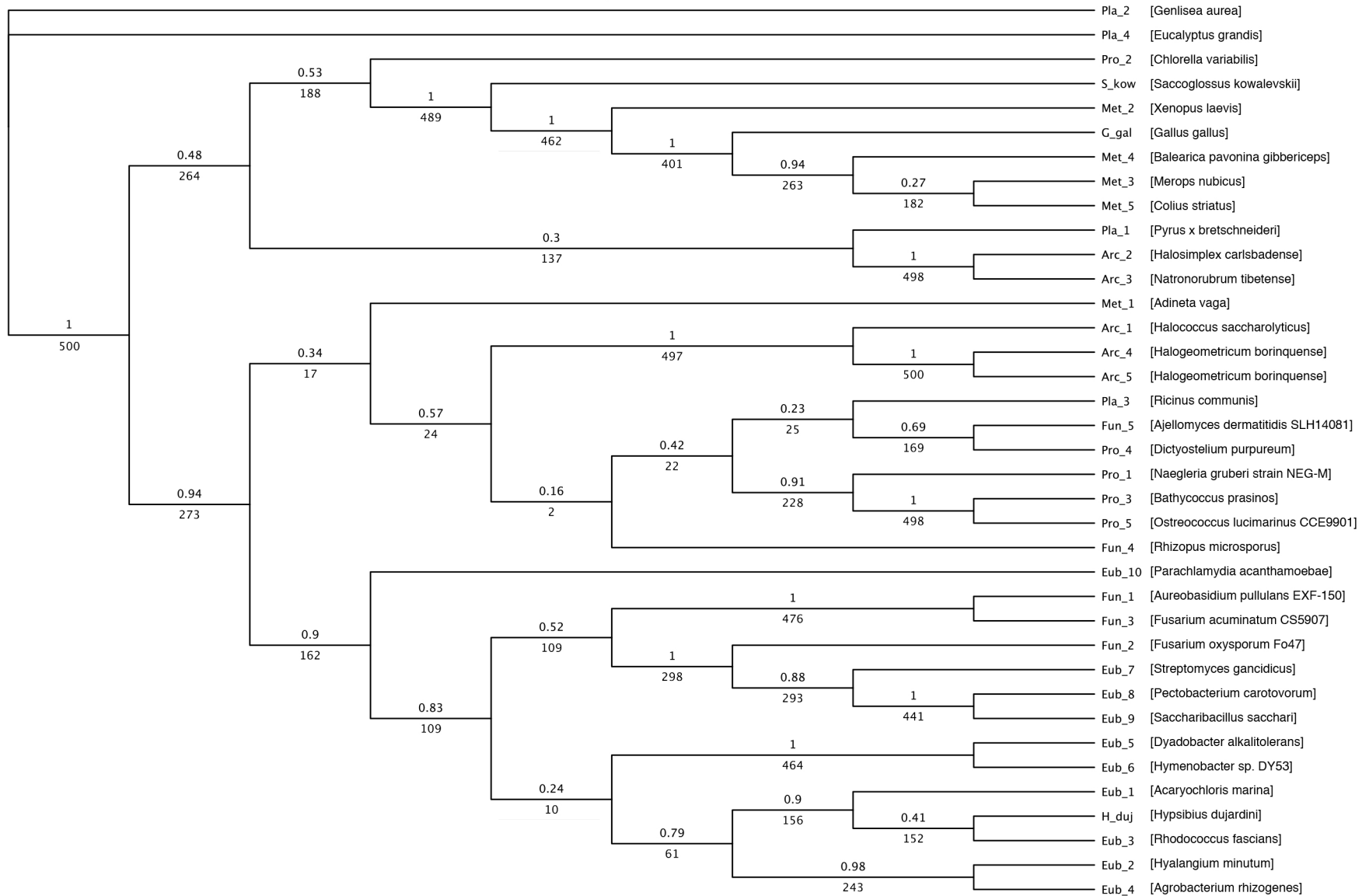

snap_masked_scaffold126_size77140_processed_gene_0.47
glucose-6-phosphate 1-dehydrogenase

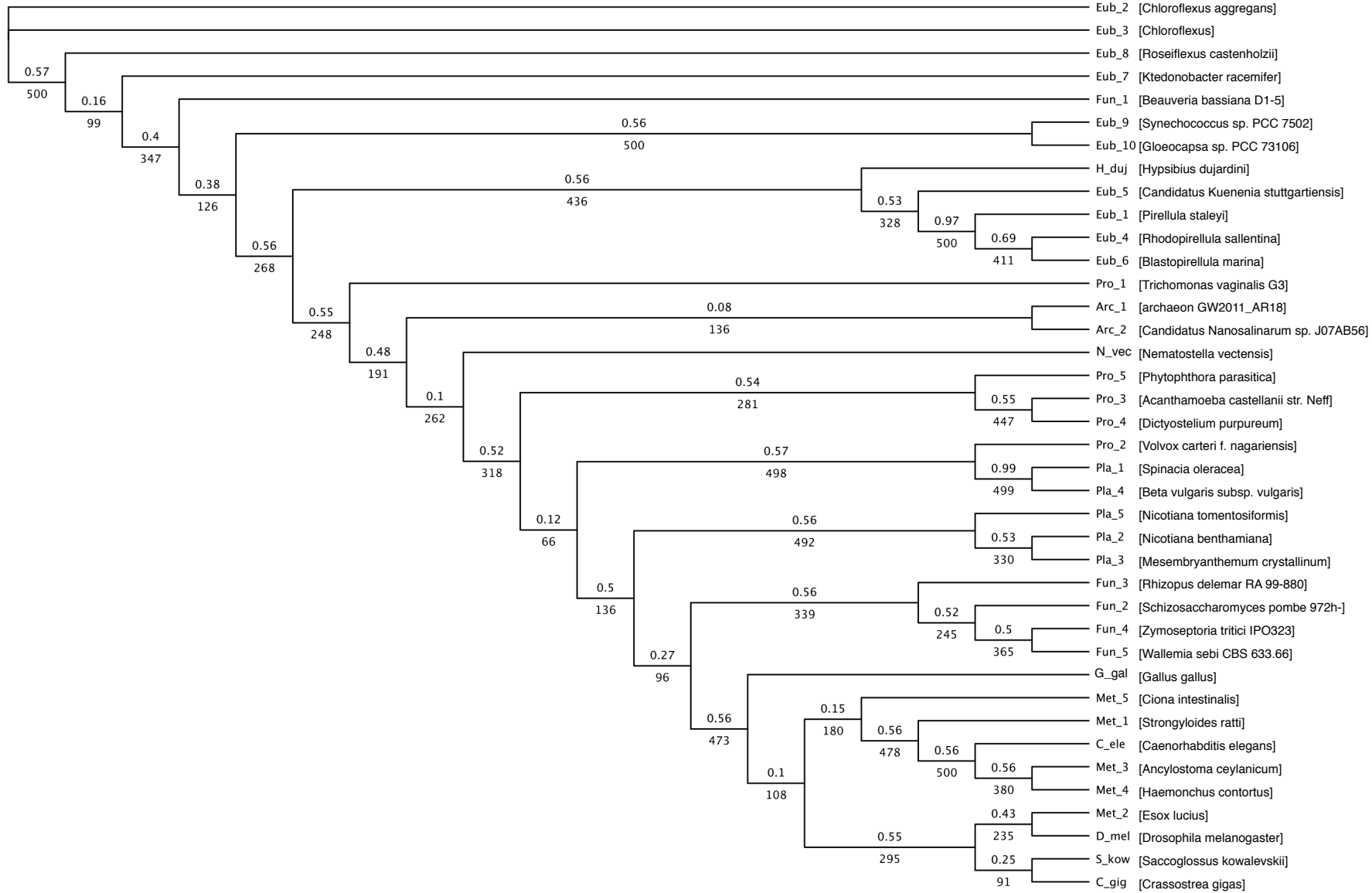

snap_masked_scaffold23_size182404_processed_gene_0.32
dihydroxy-acid dehydratase

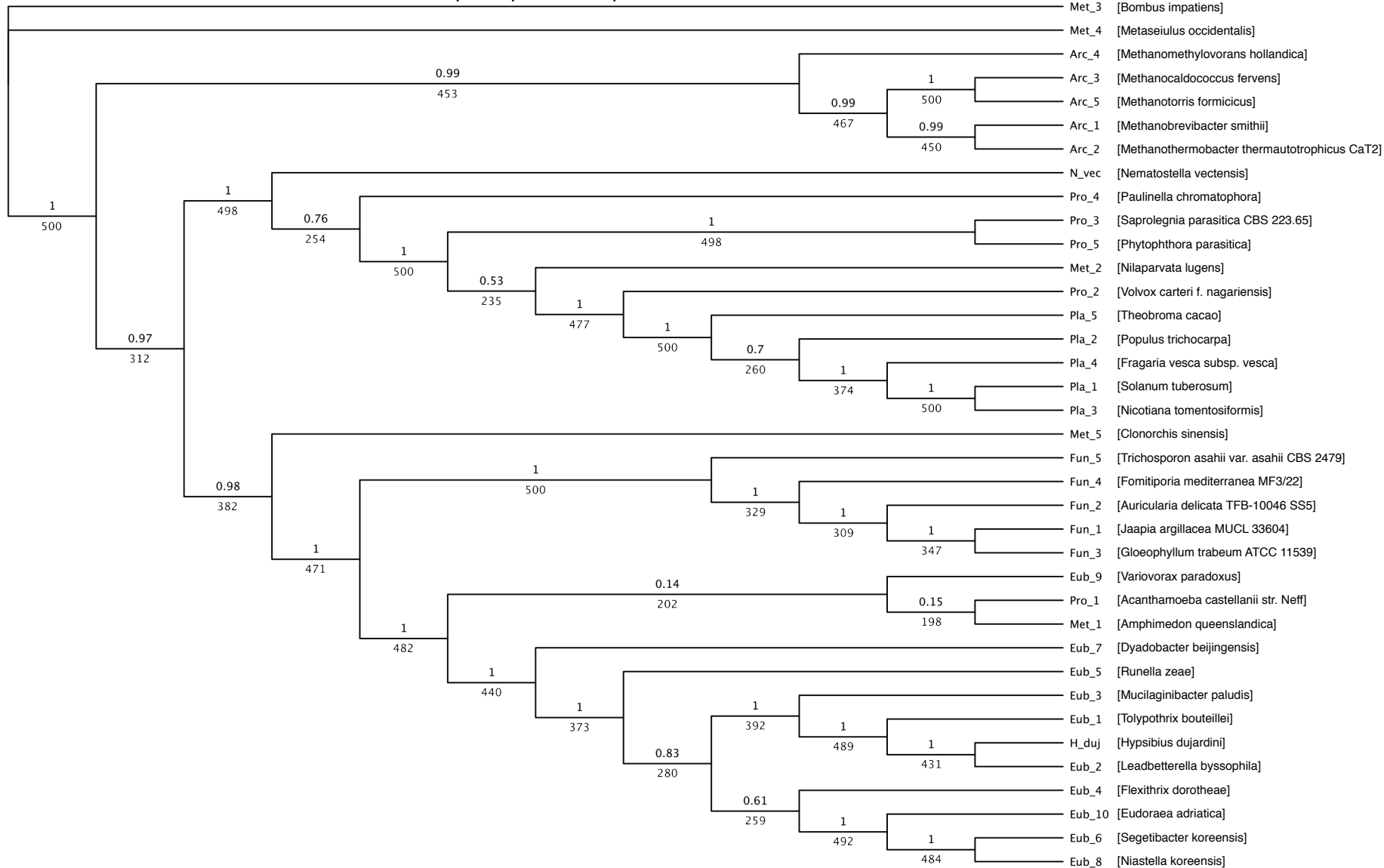

snap_masked_scaffold10_size447749_processed_gene_3.47

endo-1,4-beta-xylanase

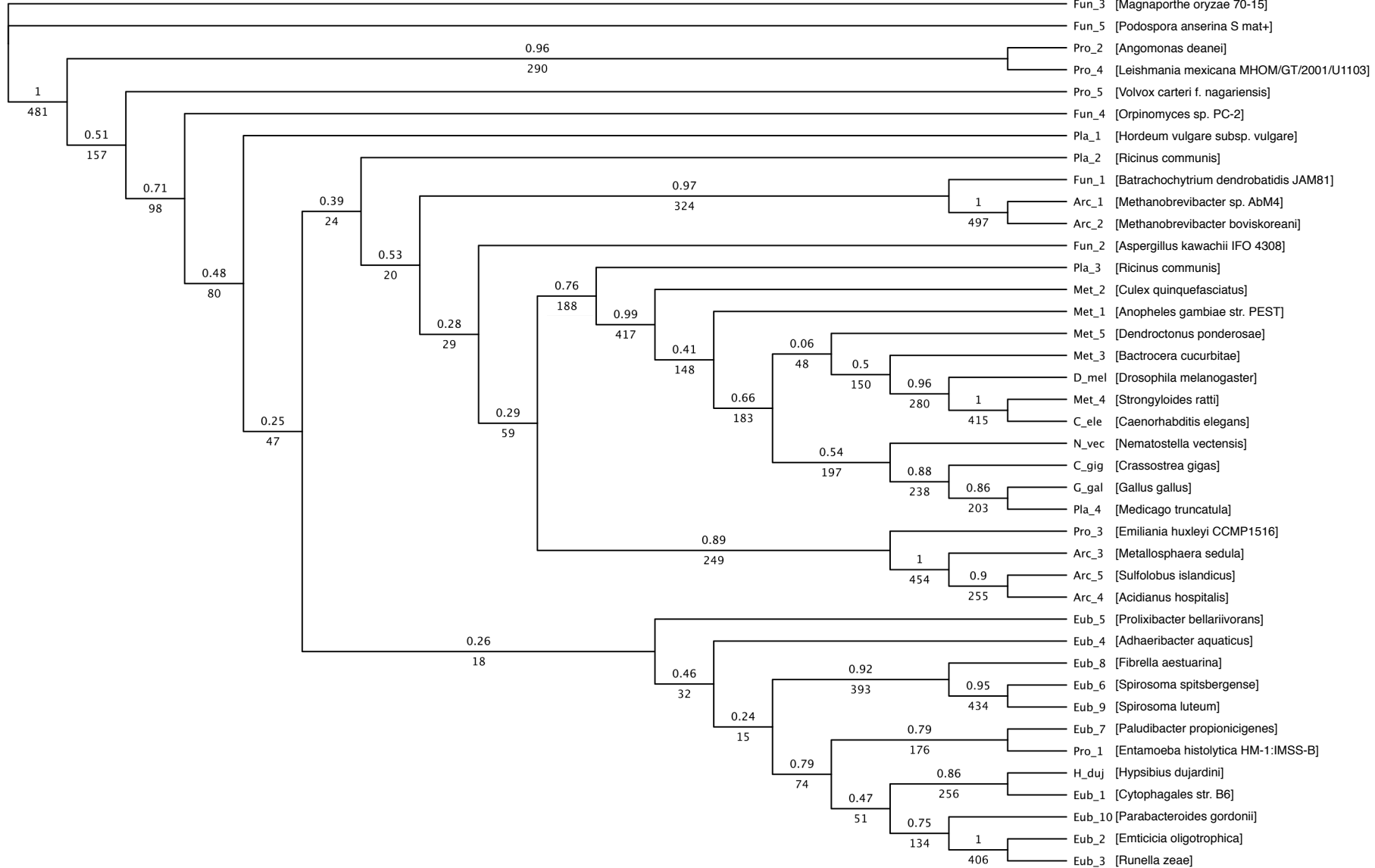

snap_masked_scaffold10_size447749_processed_gene_1.21
hypothetical protein

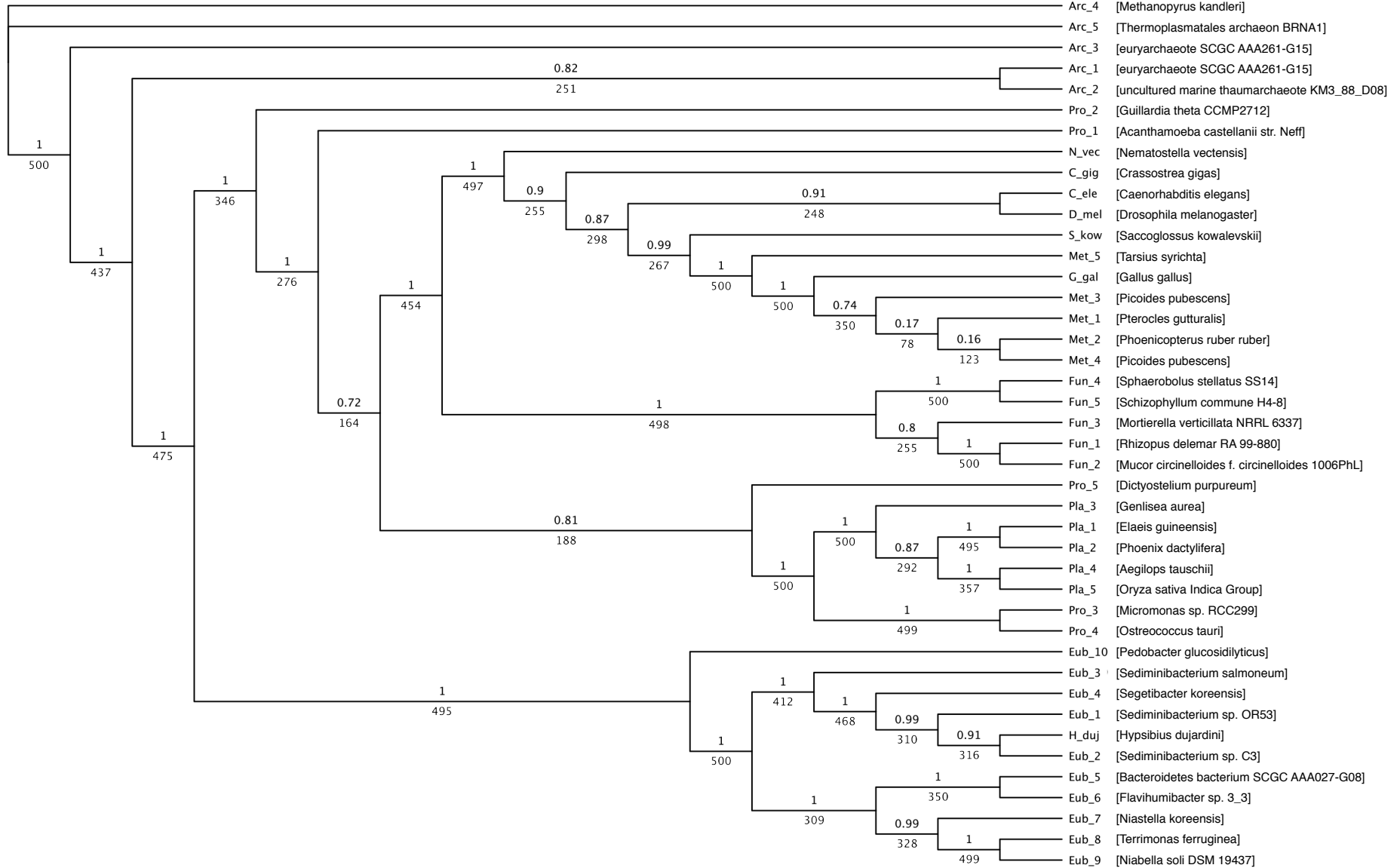

snap_masked_scaffold3_size1208507_processed_gene_1.67

flagellar P-ring protein

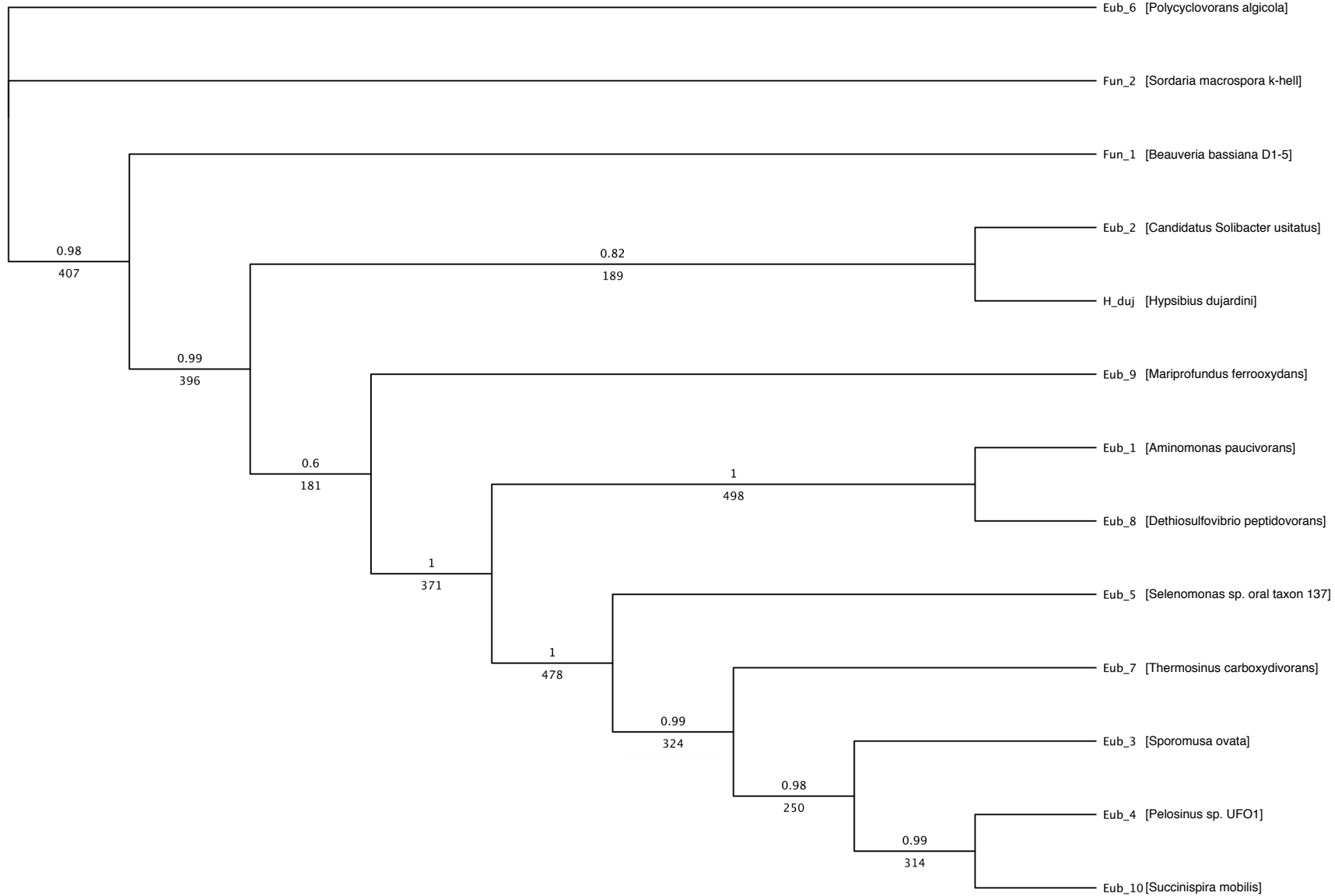

maker-scaffold16610_size5253-snap-gene-0.7

hypothetical protein

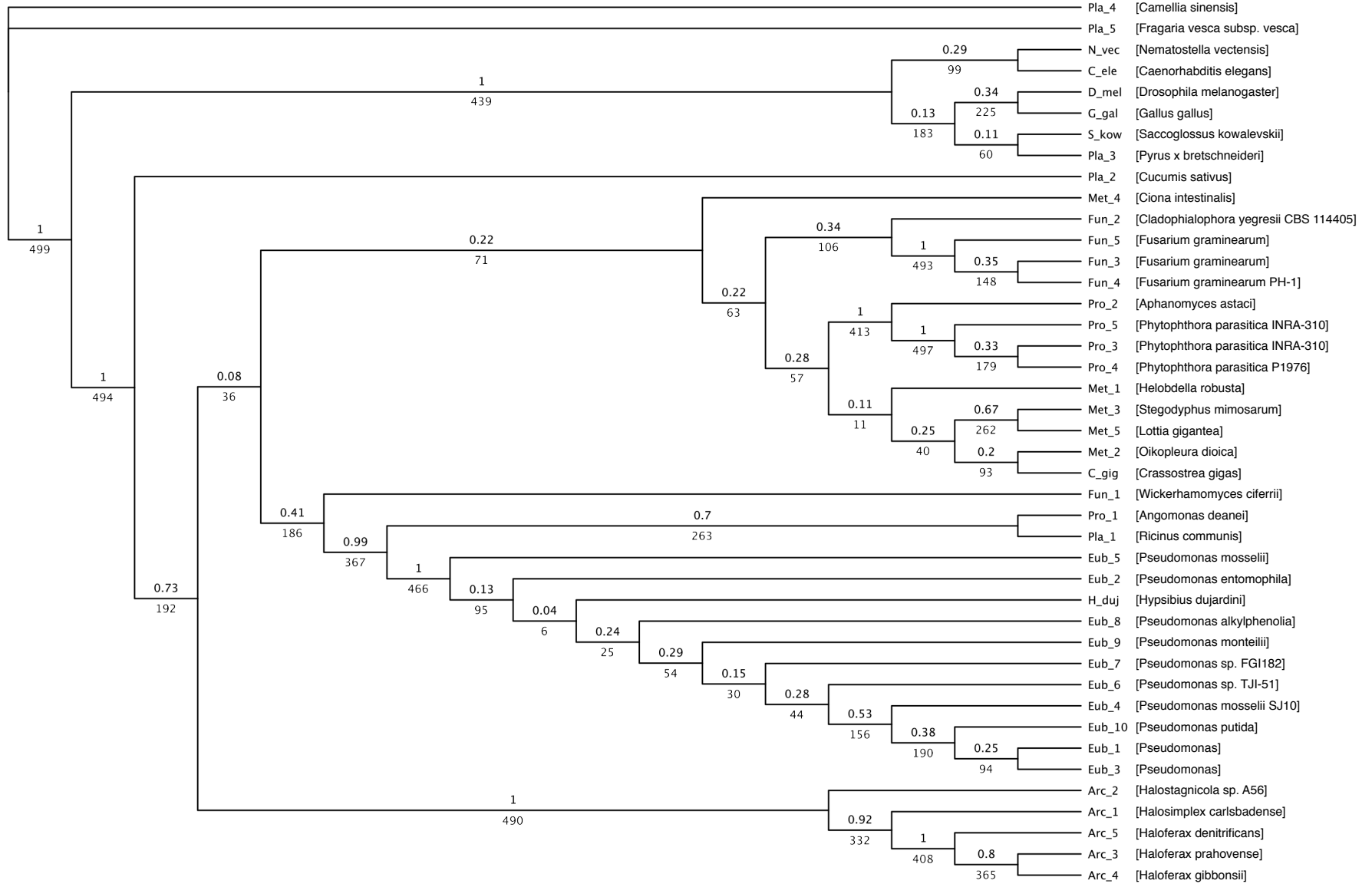

maker-scaffold5875_size12964-augustus-gene-0.12
glycoside hydrolase family 3 protein

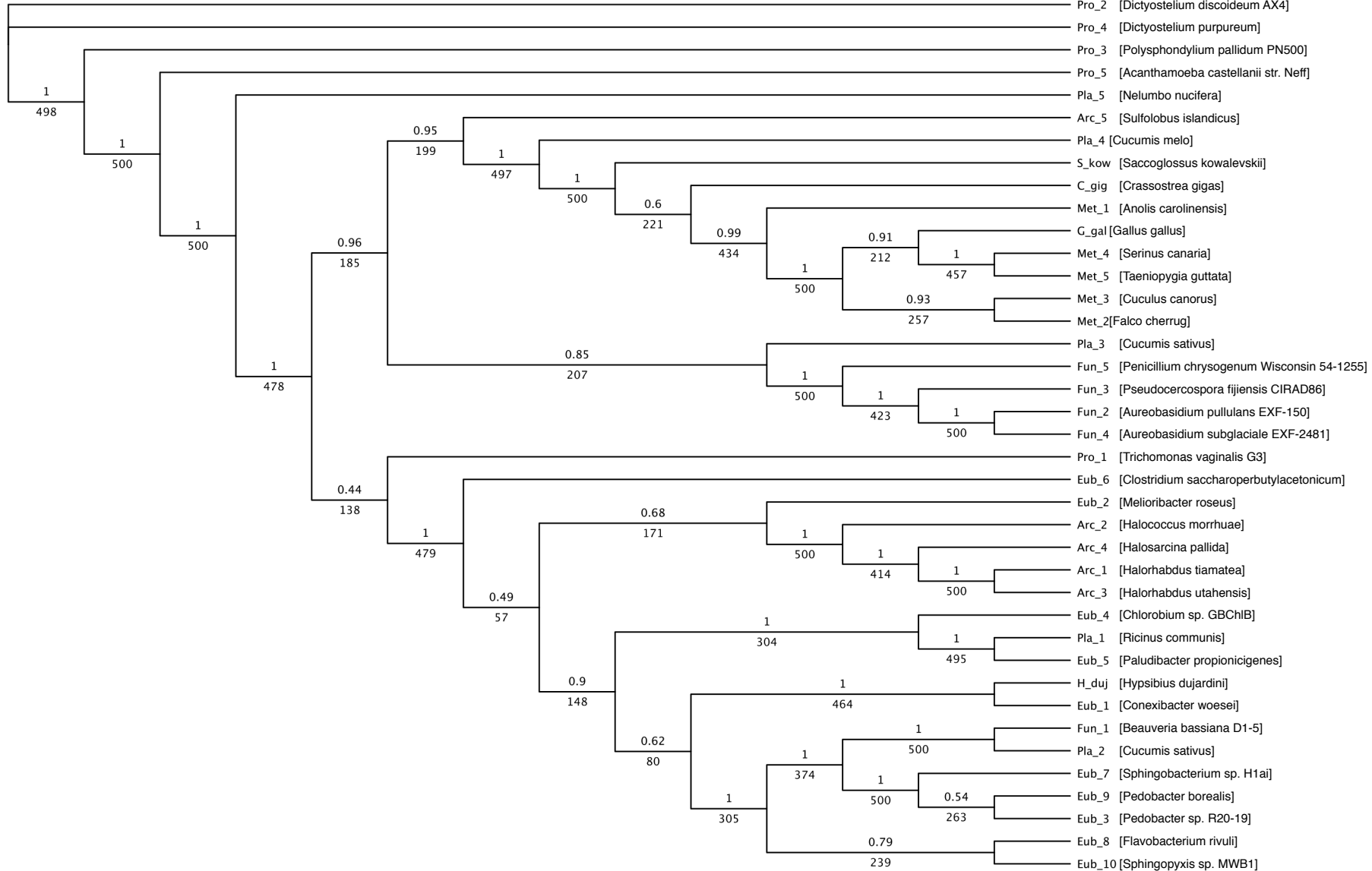

maker_scaffold23270_size2748_snap_gene_0.5
sulfate ABC transporter ATP-binding protein

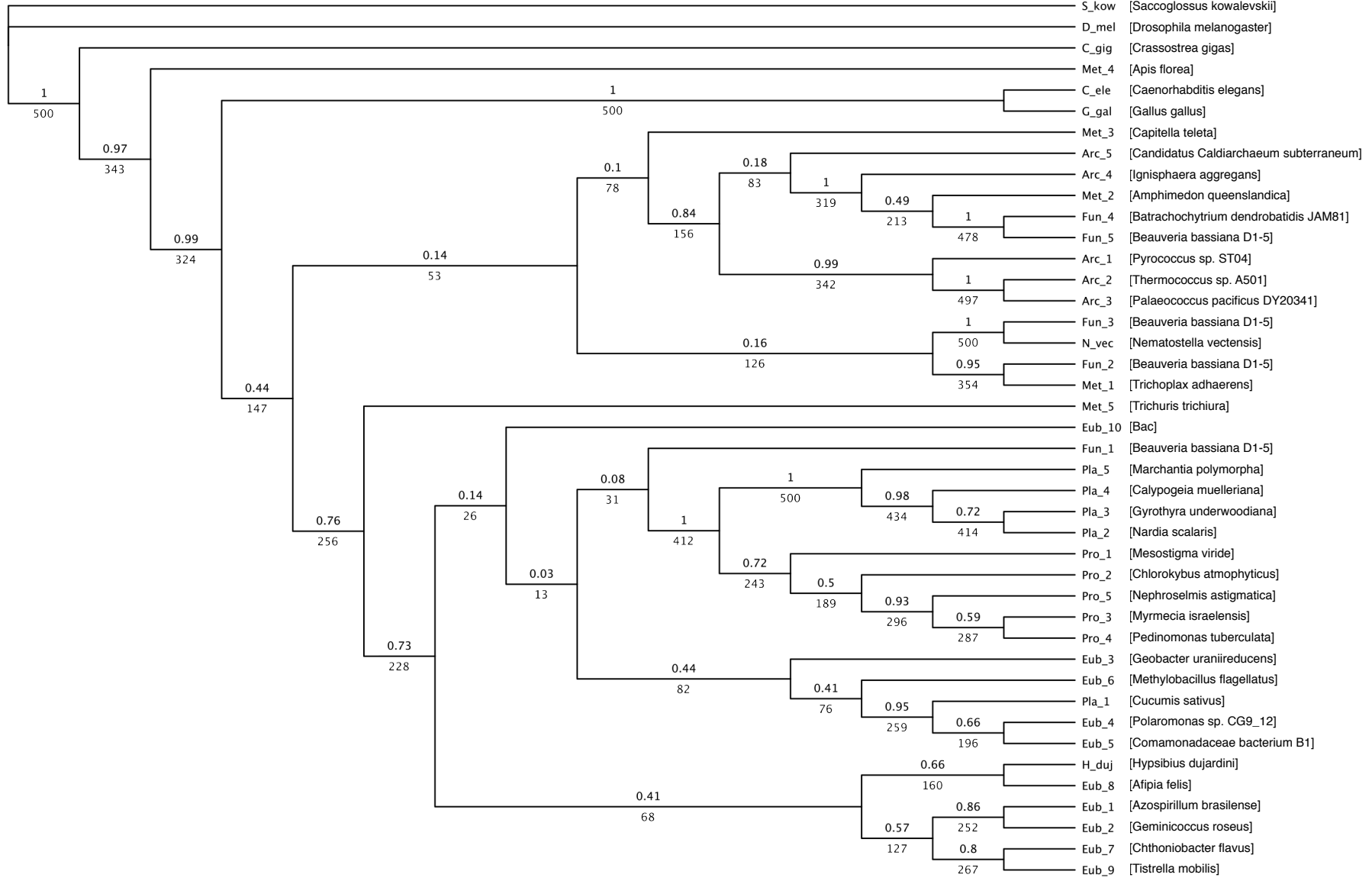

hydroxyethylthiazole kinase

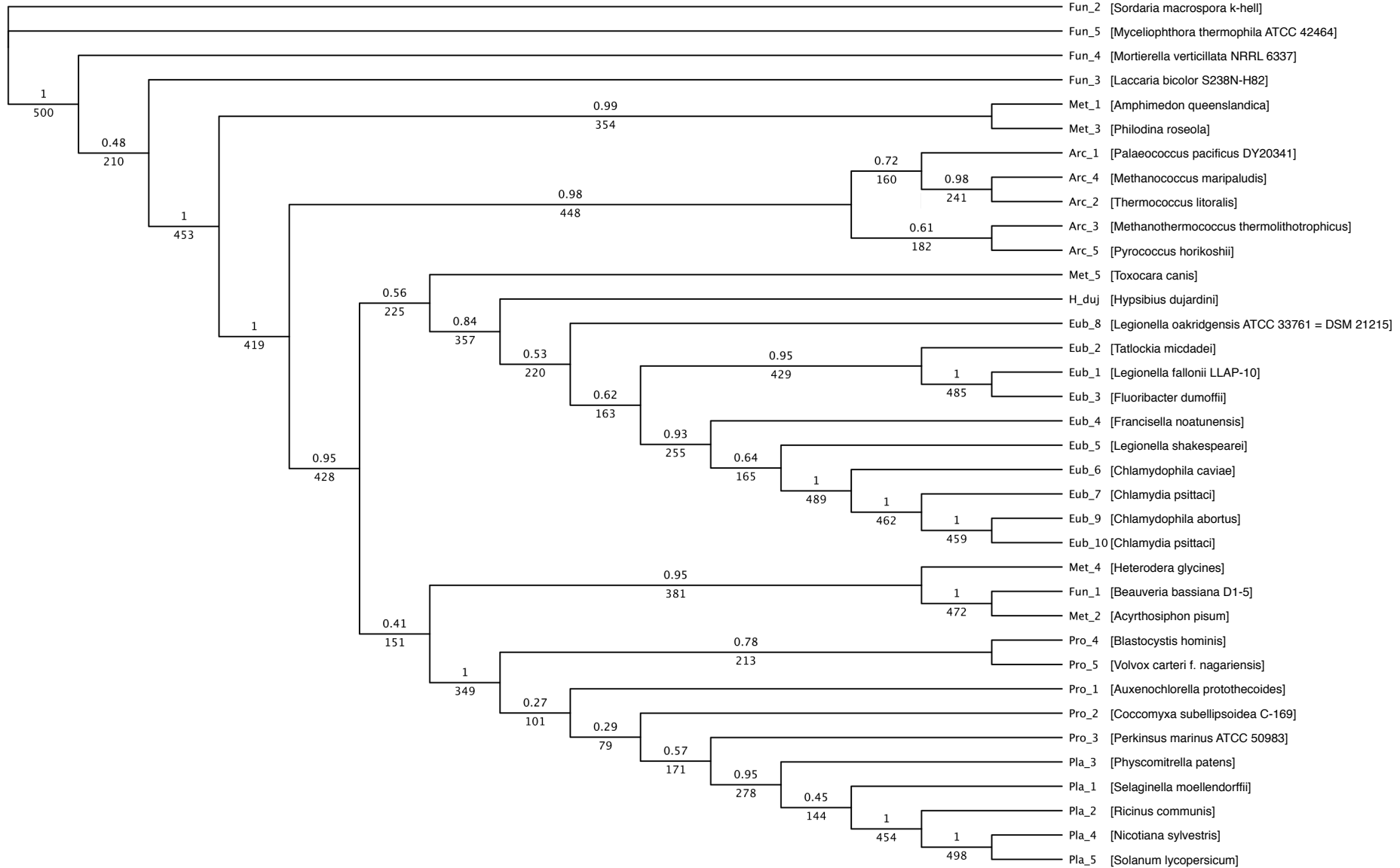

maker_scaffold13328_size7081_snap_gene_0.6

predicted protein

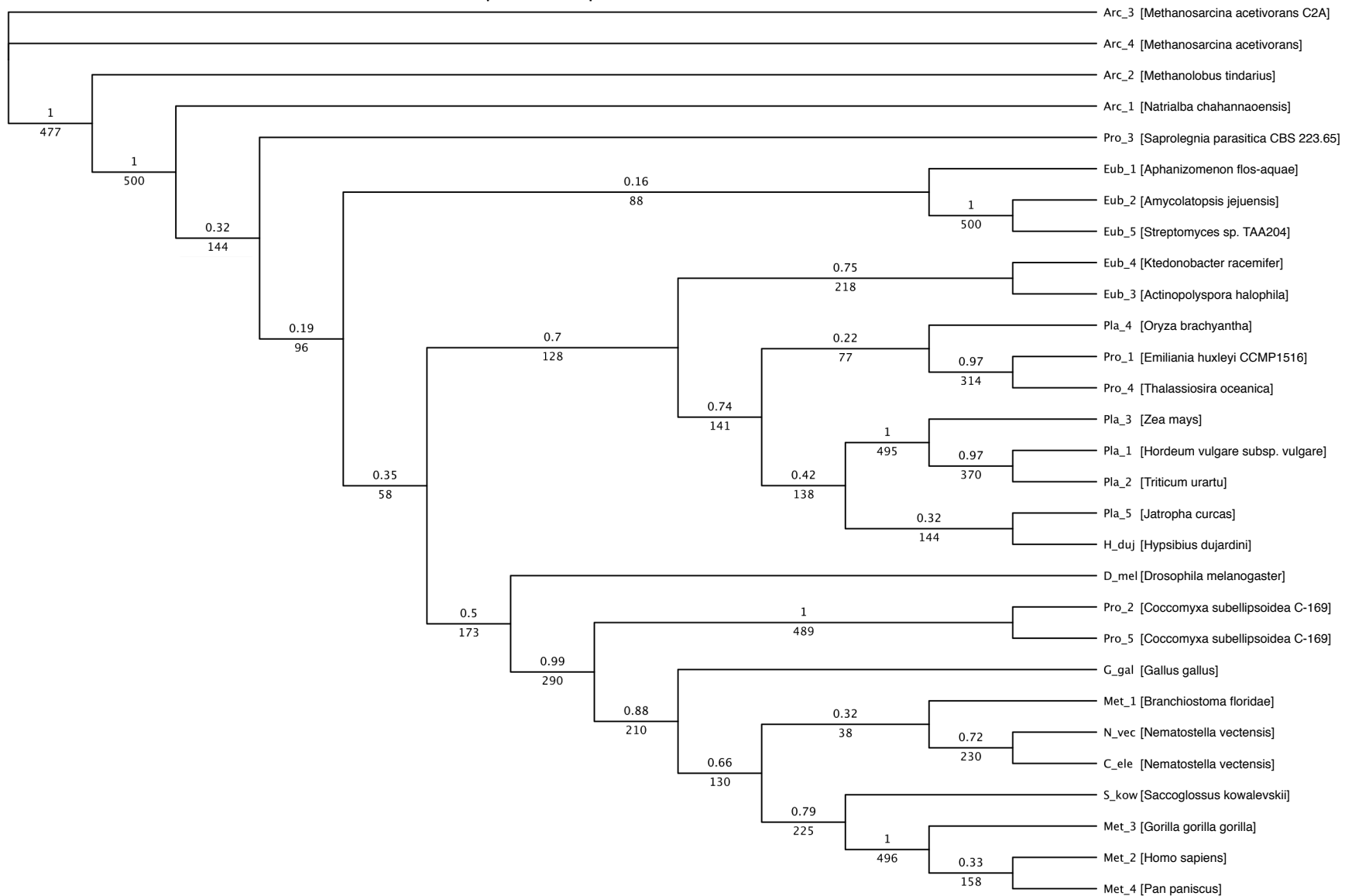

maker_scaffold12736_size7442_augustus_gene_0.15

nitrate ABC transporter ATP-binding protein

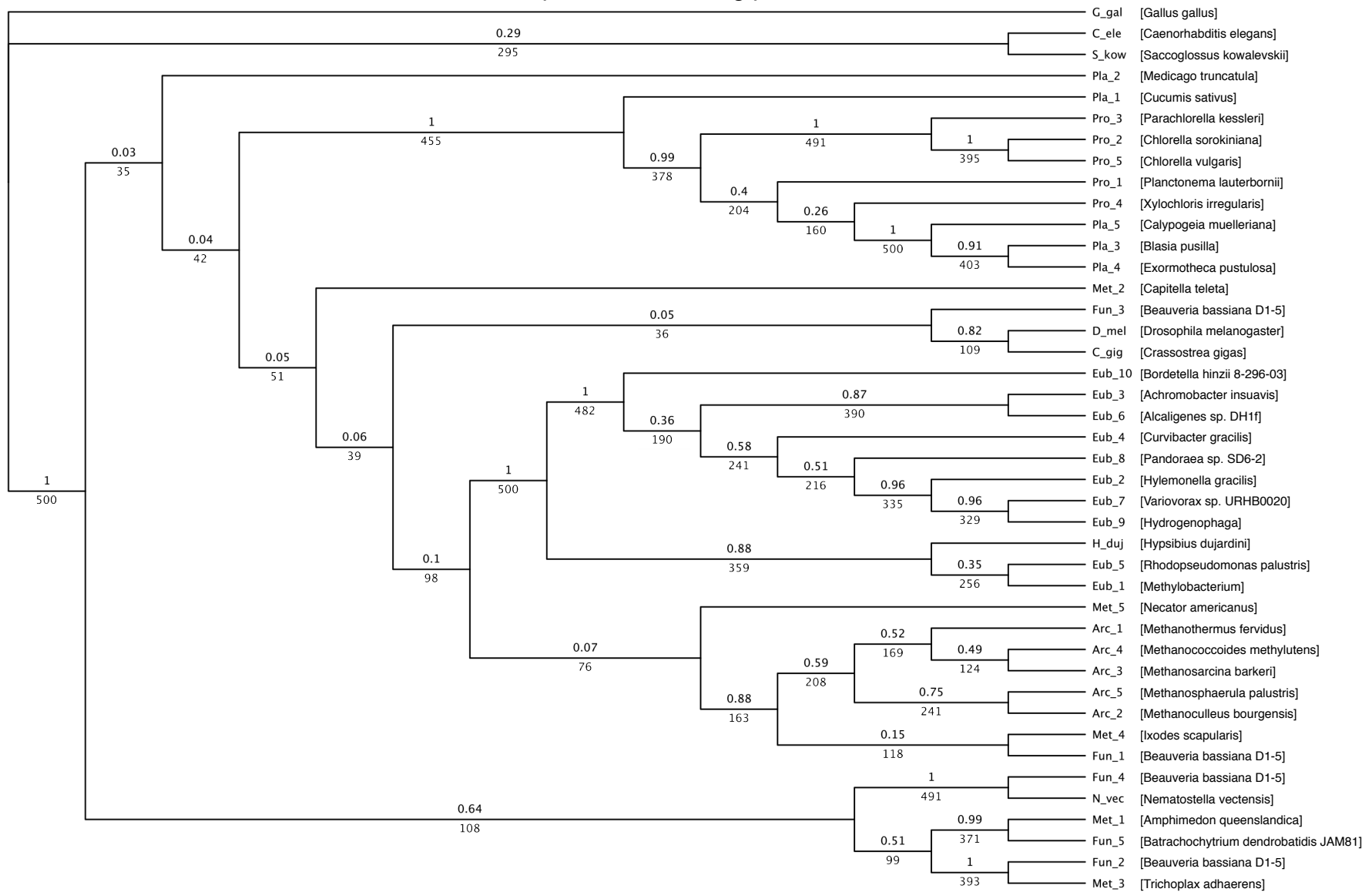

maker_scaffold10072_size9001_snap_gene_0.11
hypothetical protein

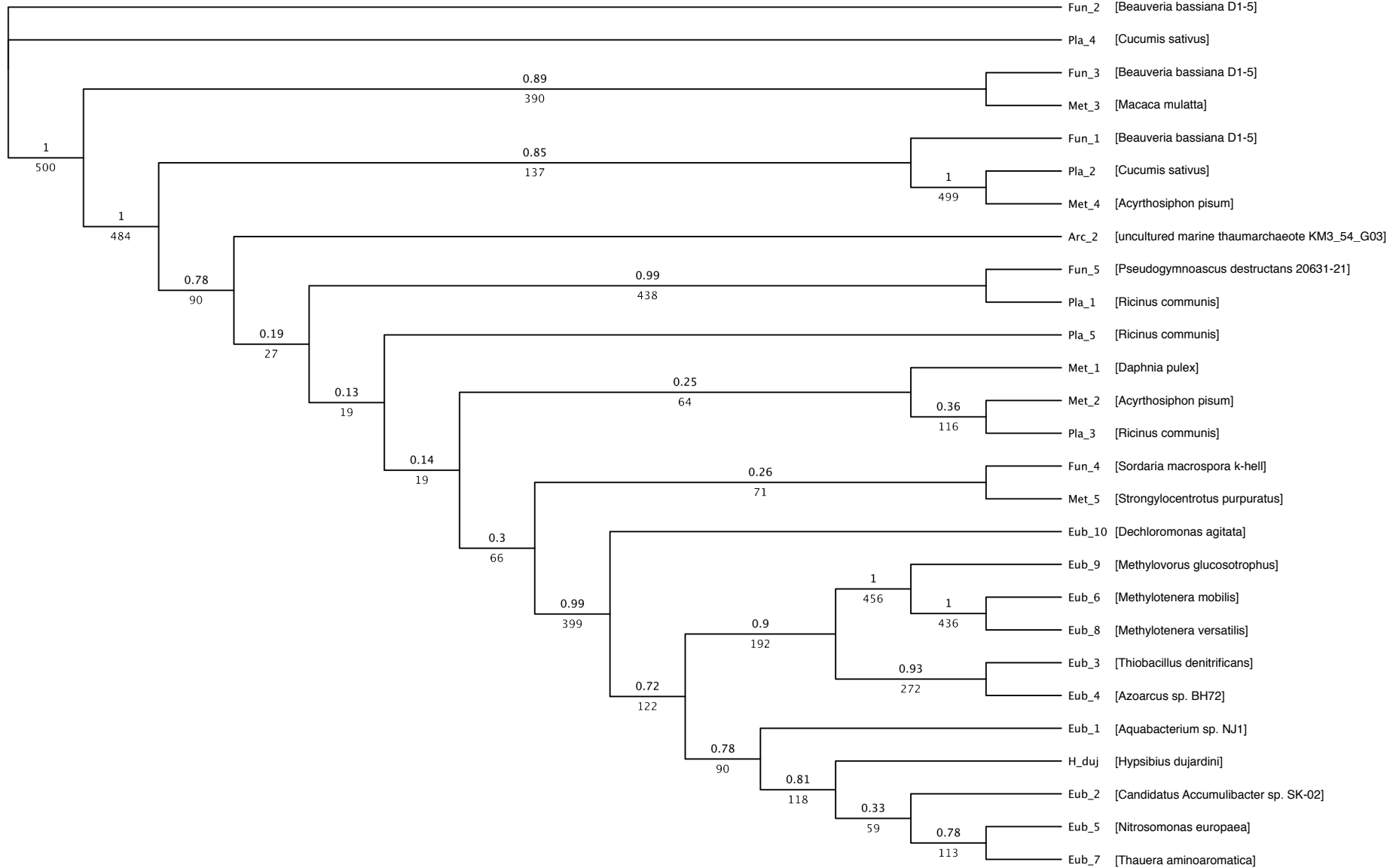

HrcA family transcriptional regulator

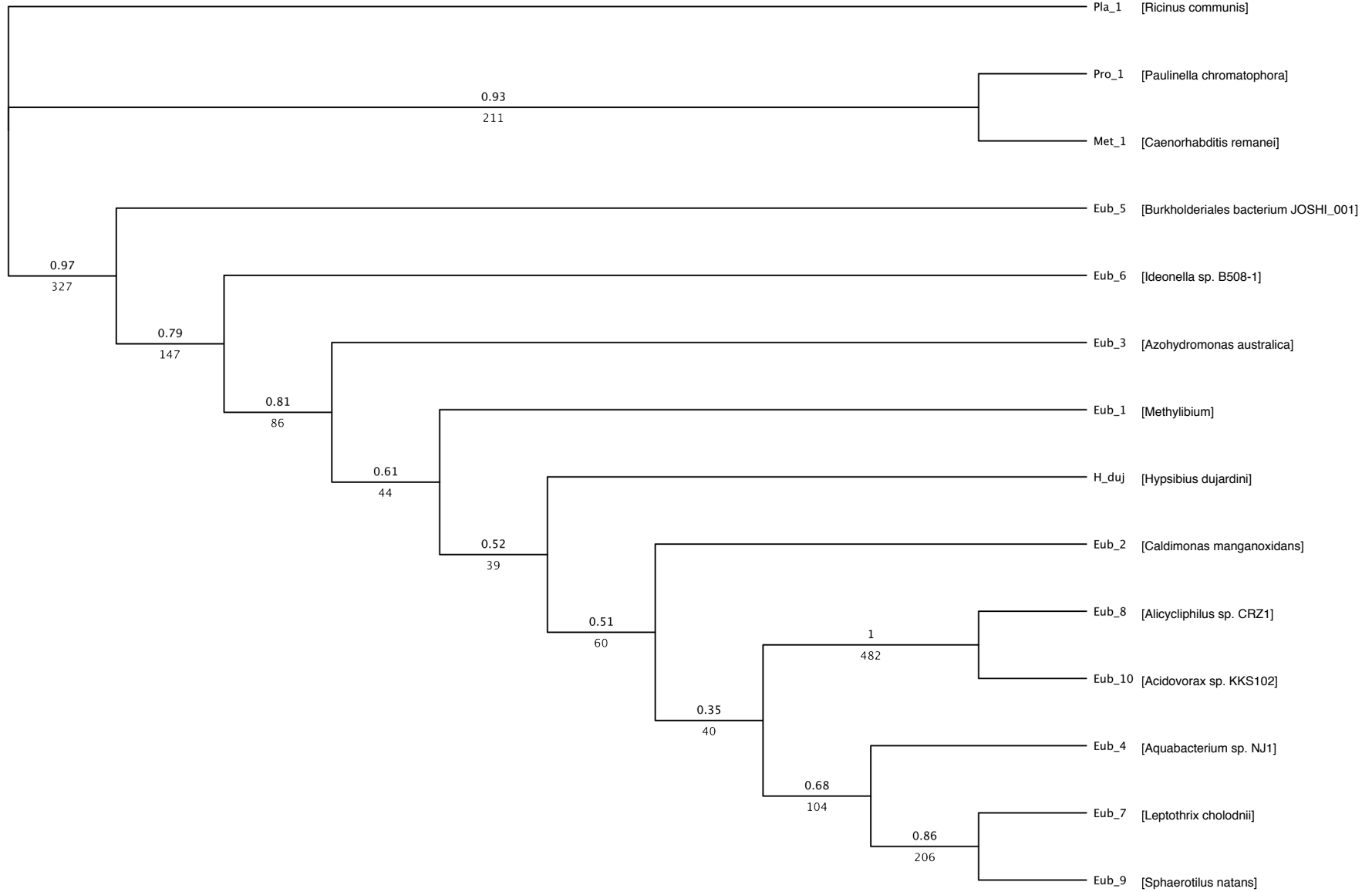

maker_scaffold7284_snap_gene_0.10
hypothetical protein

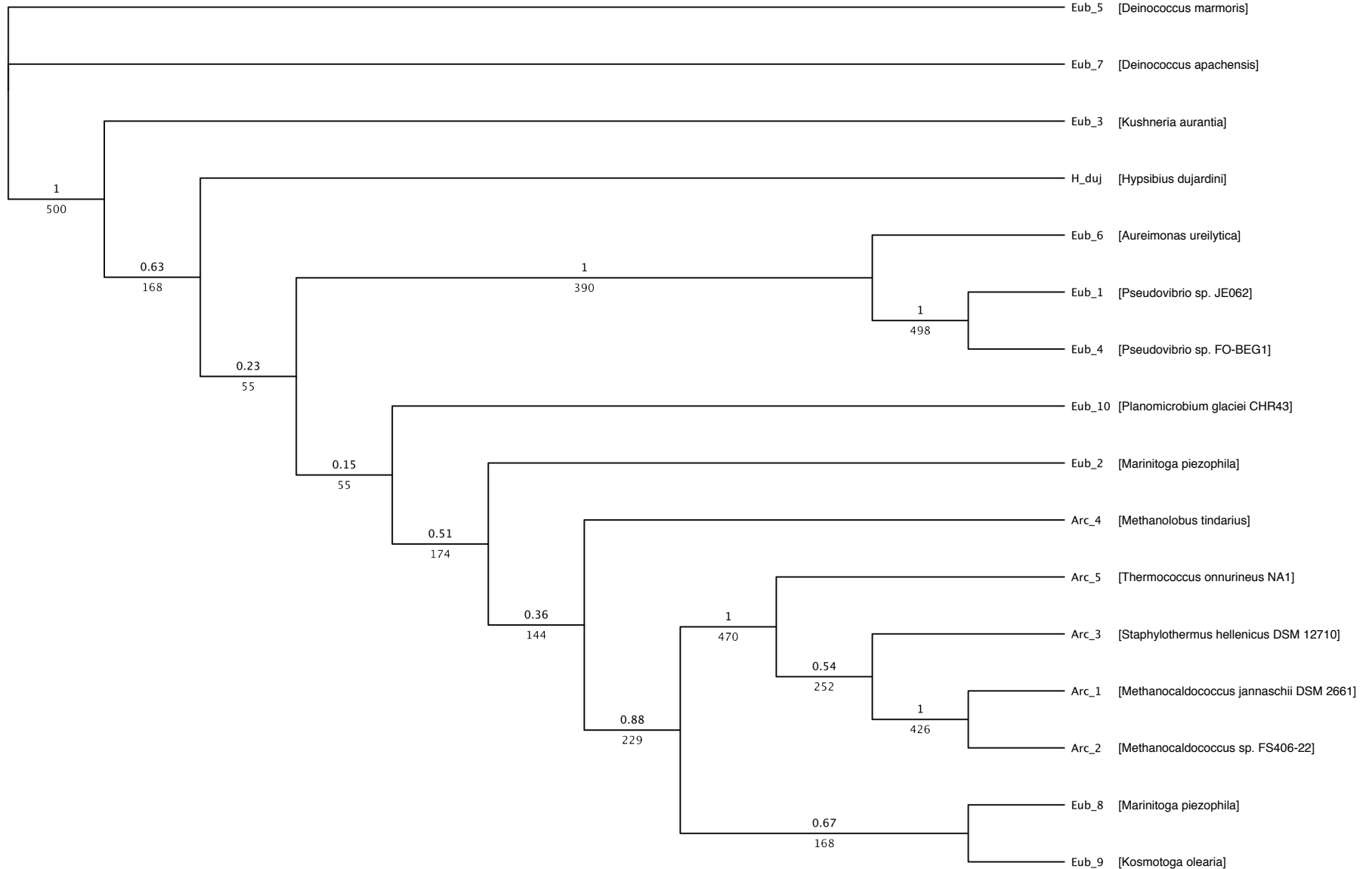

maker_scaffold6957_snap_gene_0.14
hypothetical protein

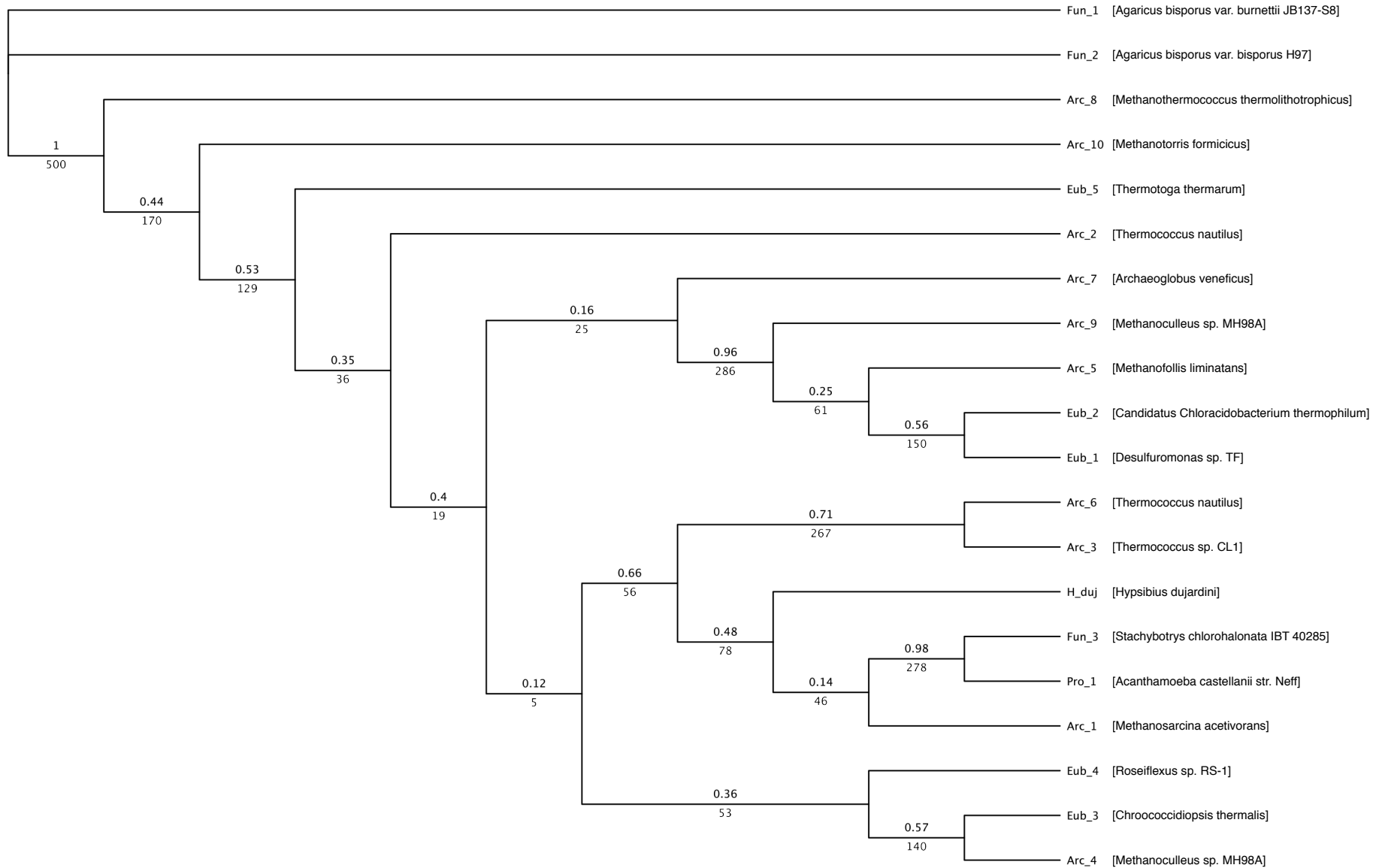

maker_scaffold6668_size11878_snap_gene_0.12

hypothetical protein

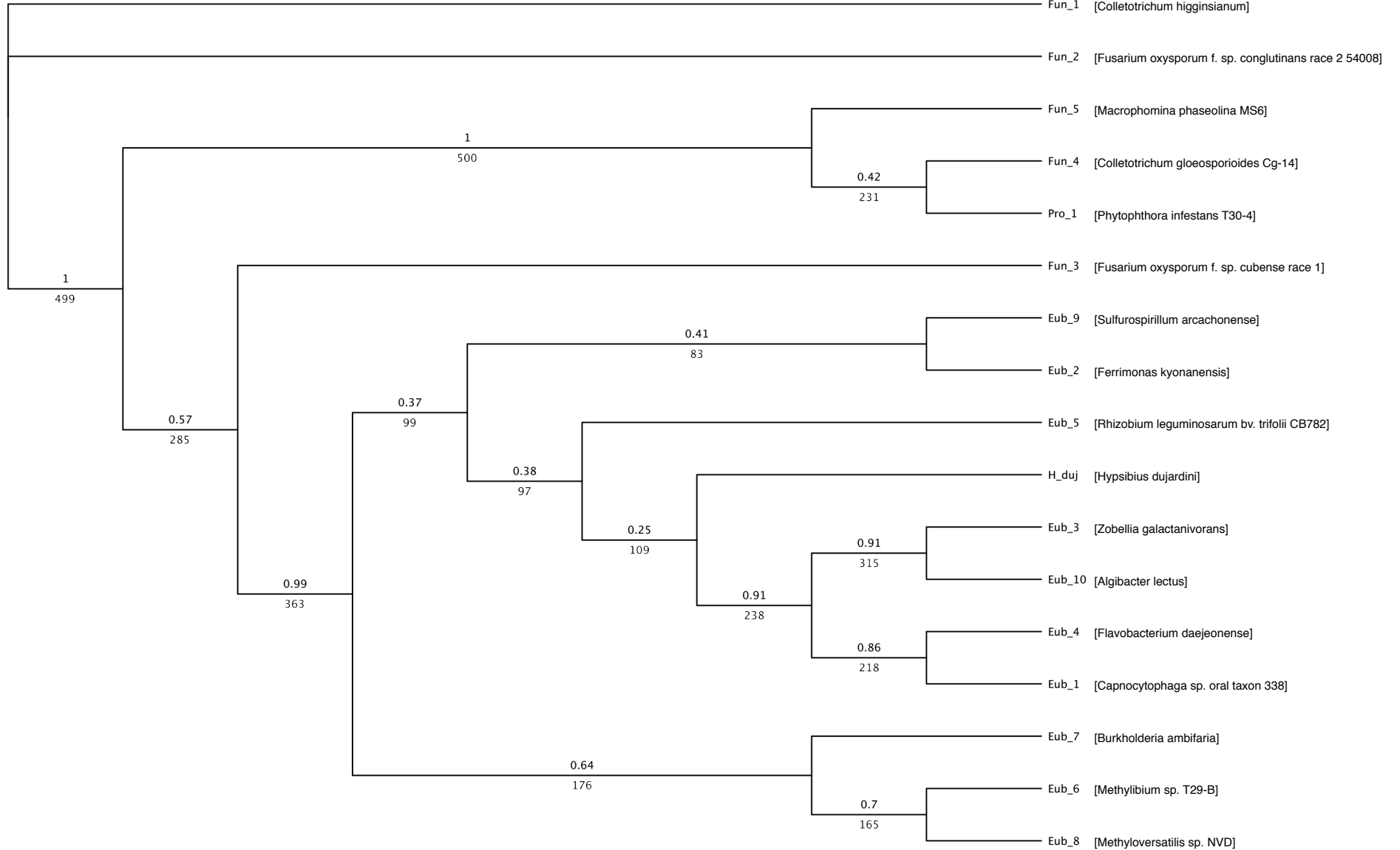

maker_scaffold6505_size12078_augustus_gene_0.8

predicted protein

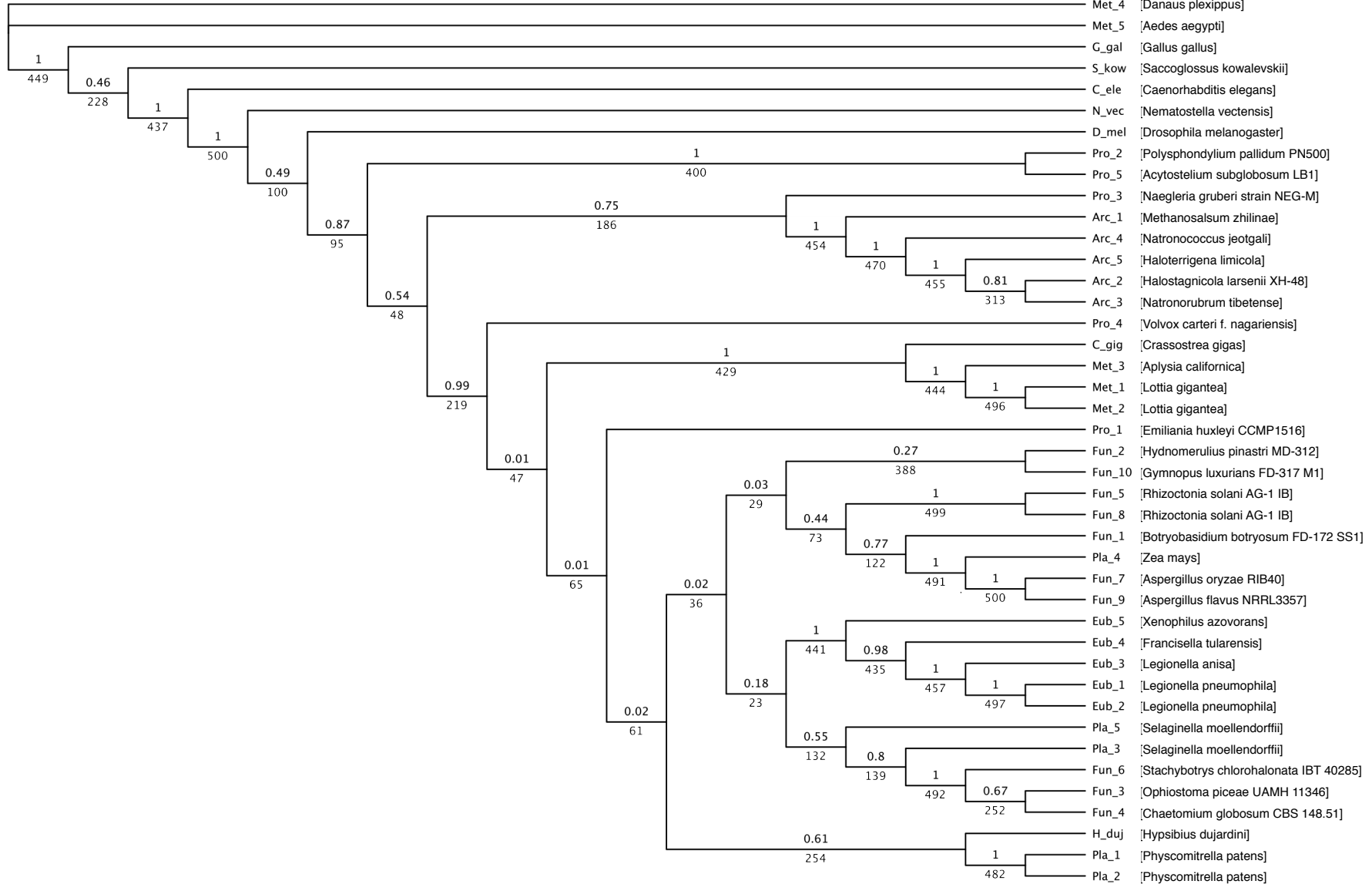

maker_scaffold6486_size12099_snap_gene_0.18

hypothetical protein

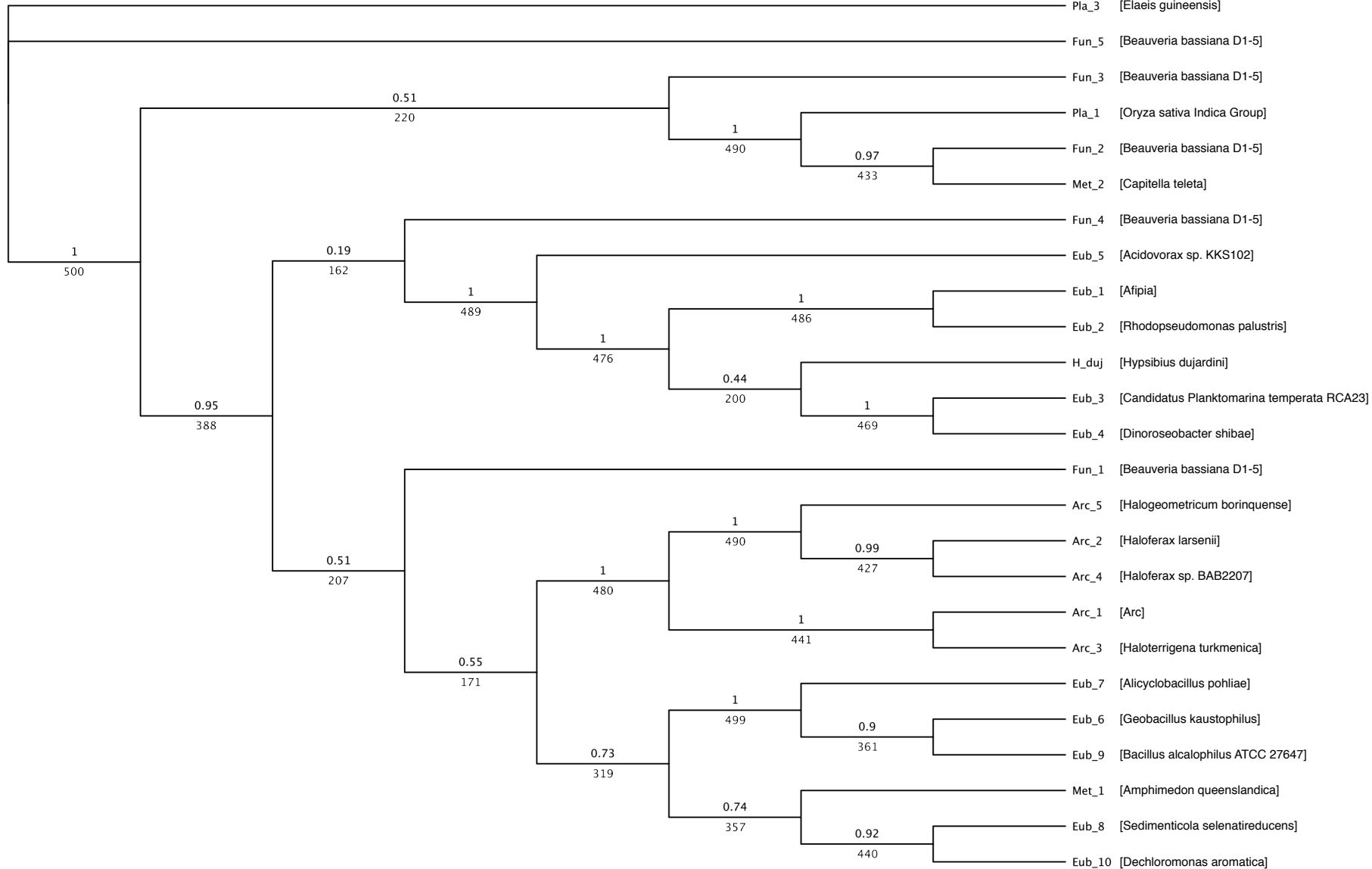

maker_scaffold6361_size12239_augustus_gene_0.6

hypothetical protein MELLADRAFT_23711

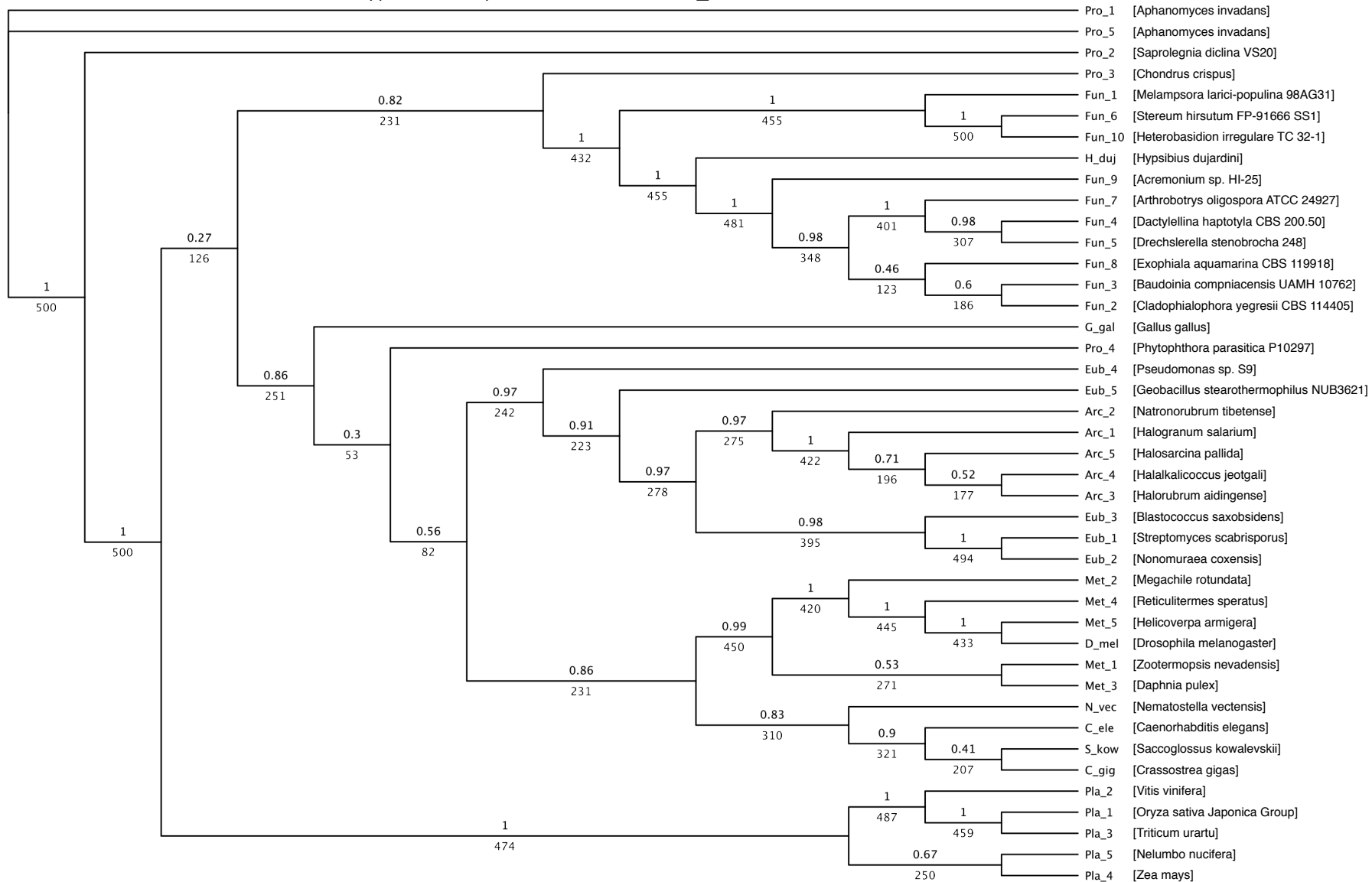

DJ-1/Pfpl family protein

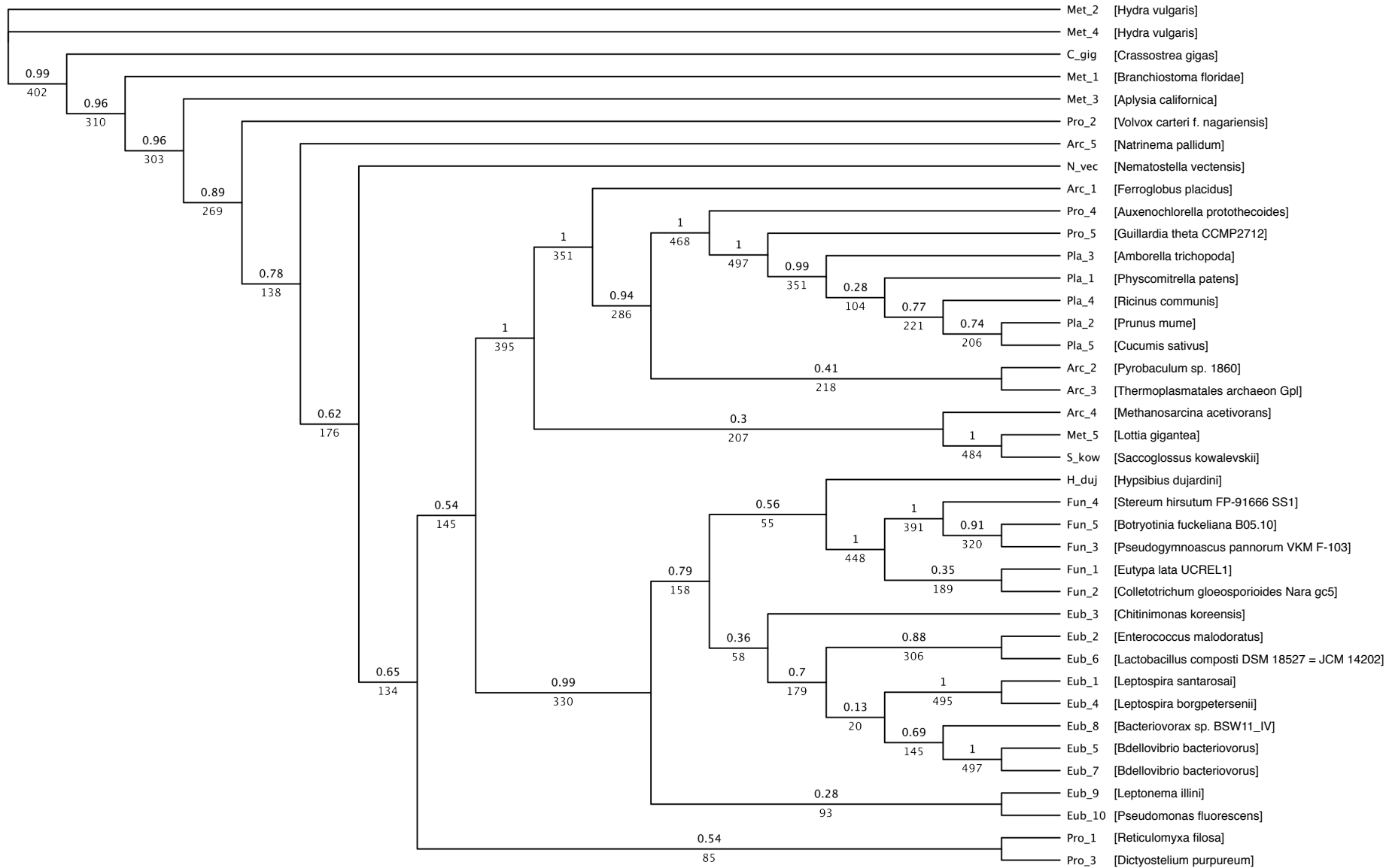

maker_scaffold6104_size12615_augustus_gene_0.9

hypothetical protein W97_07117

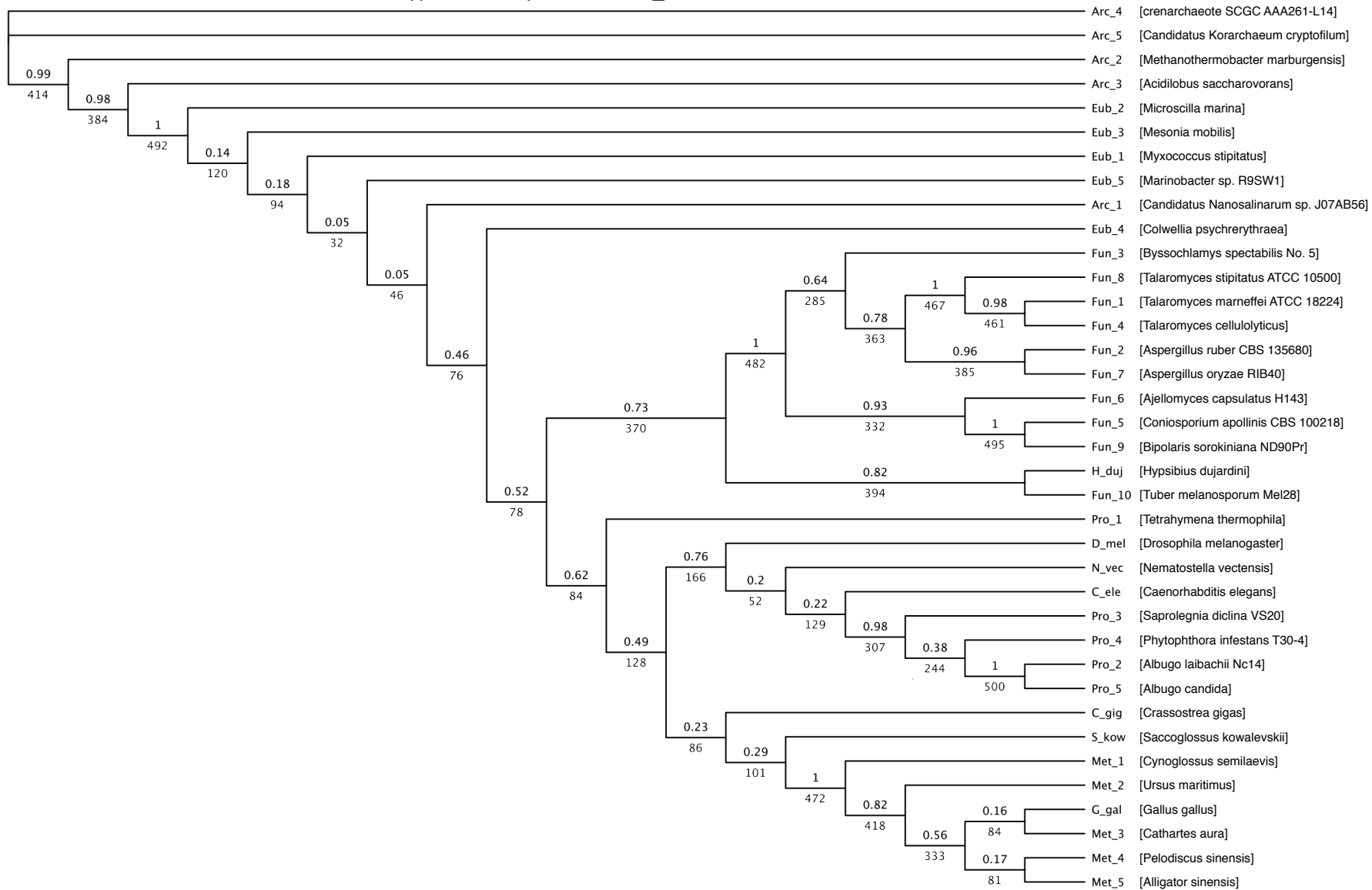

maker_scaffold5875_size12964_augustus_gene_0.12
glycoside hydrolase family 3 protein

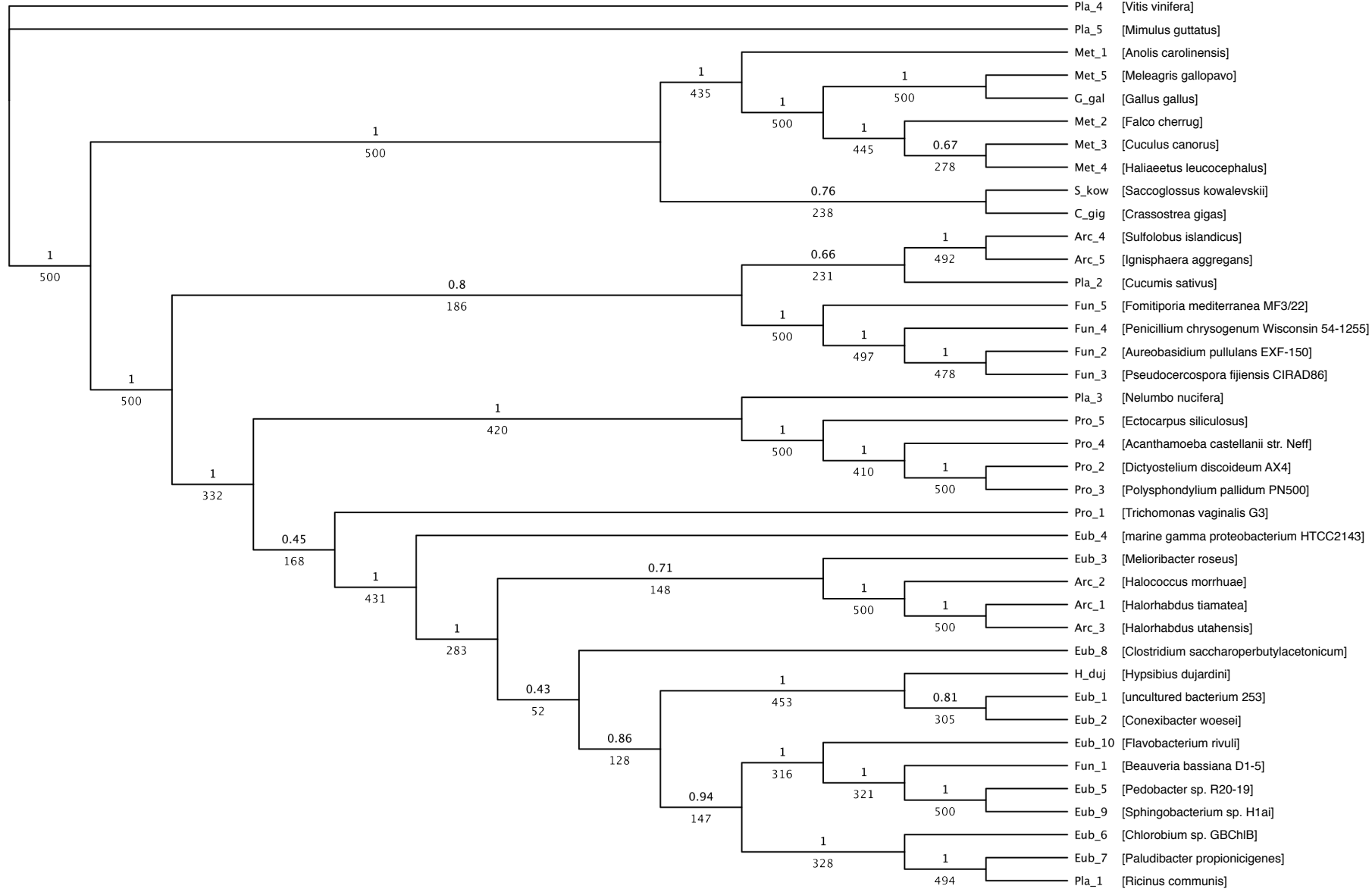

hypothetical protein mv_R860

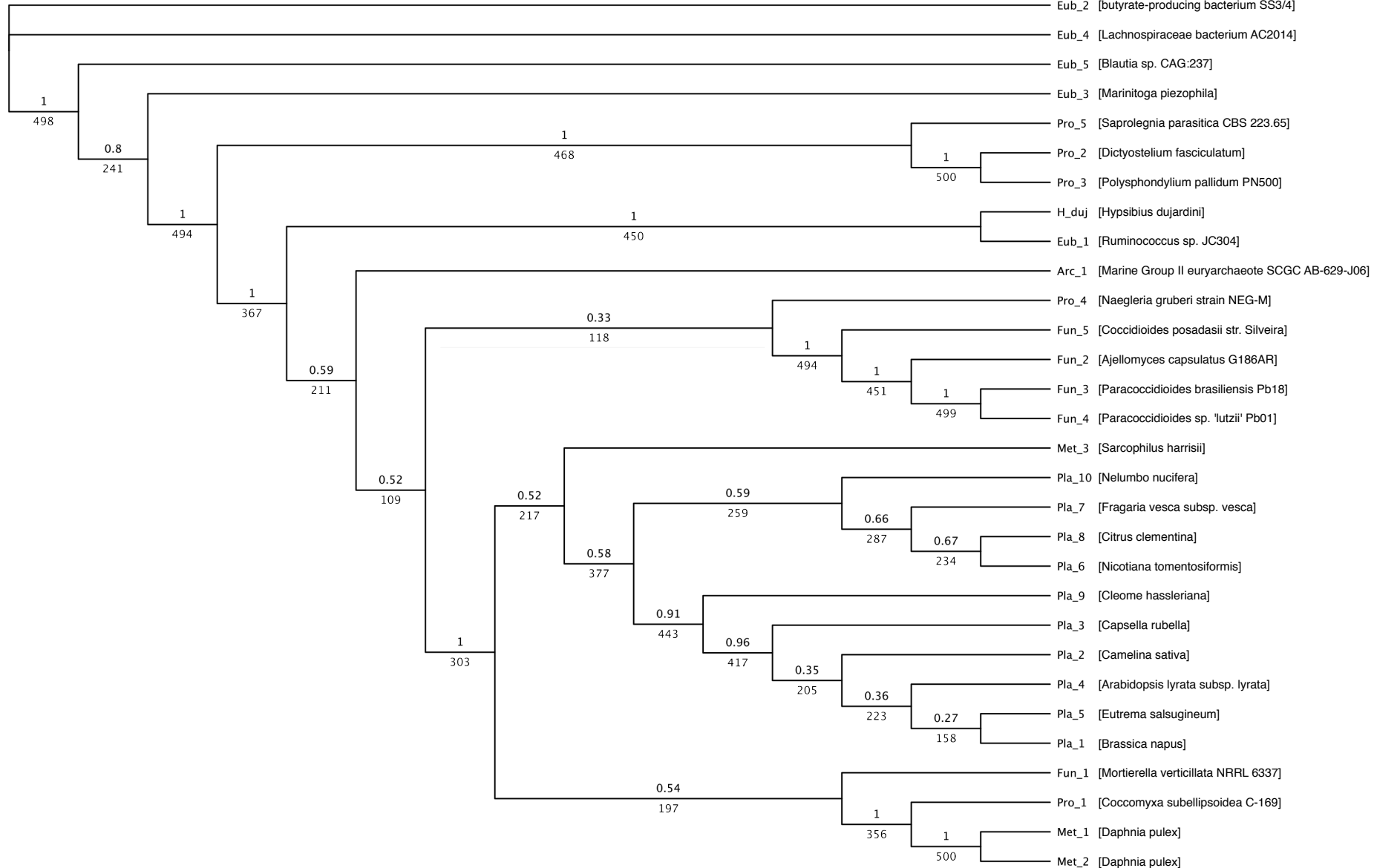

maker_scaffold5005_size27369_snap_gene_0.11

hypothetical protein H072_8118

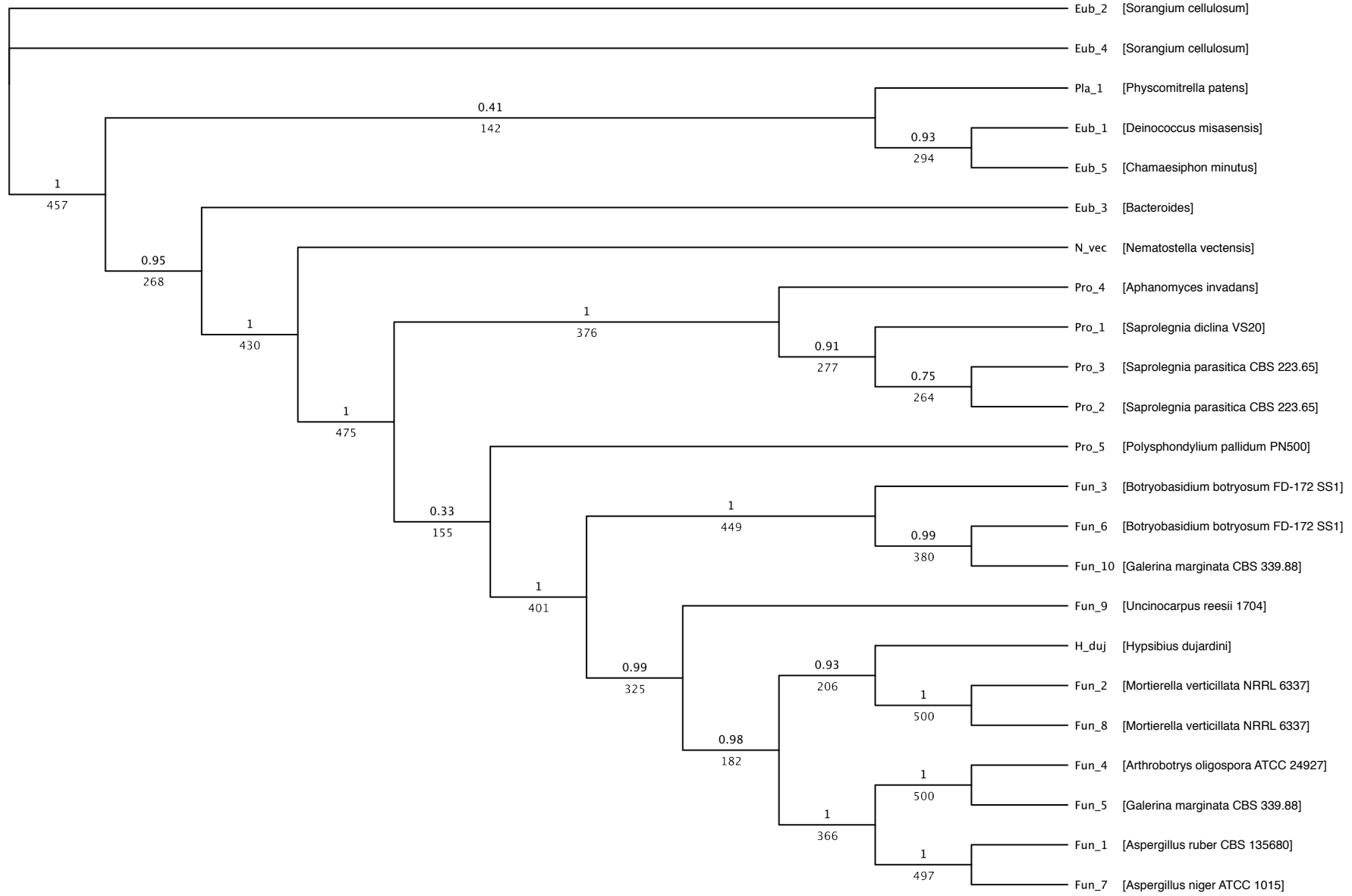

maker_scaffold4964_size23147_snap_gene_0.19
hypothetical protein SELMODRAFT_96185

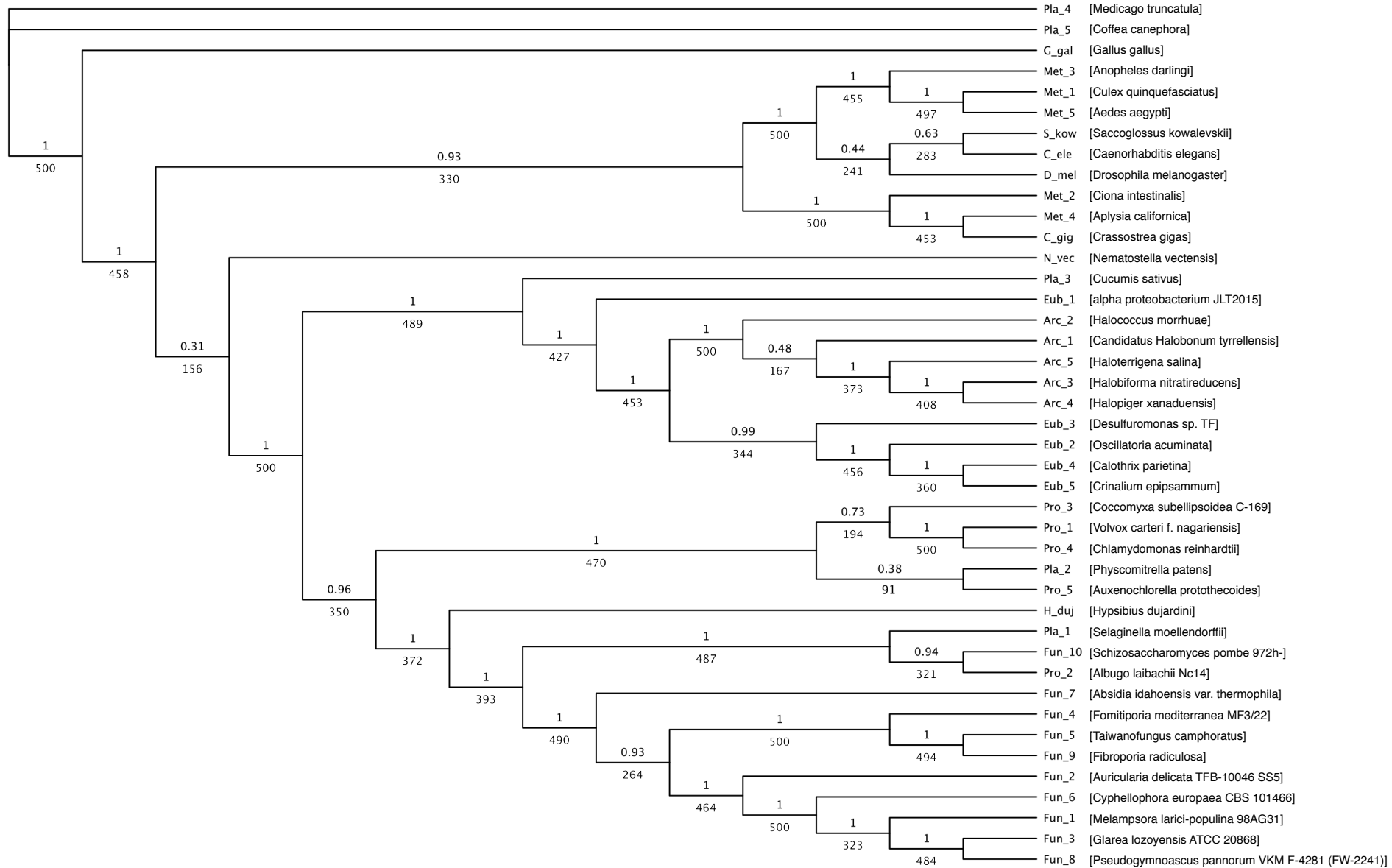

maker_scaffold4690_snap_gene_0.16
exodeoxyribonuclease III

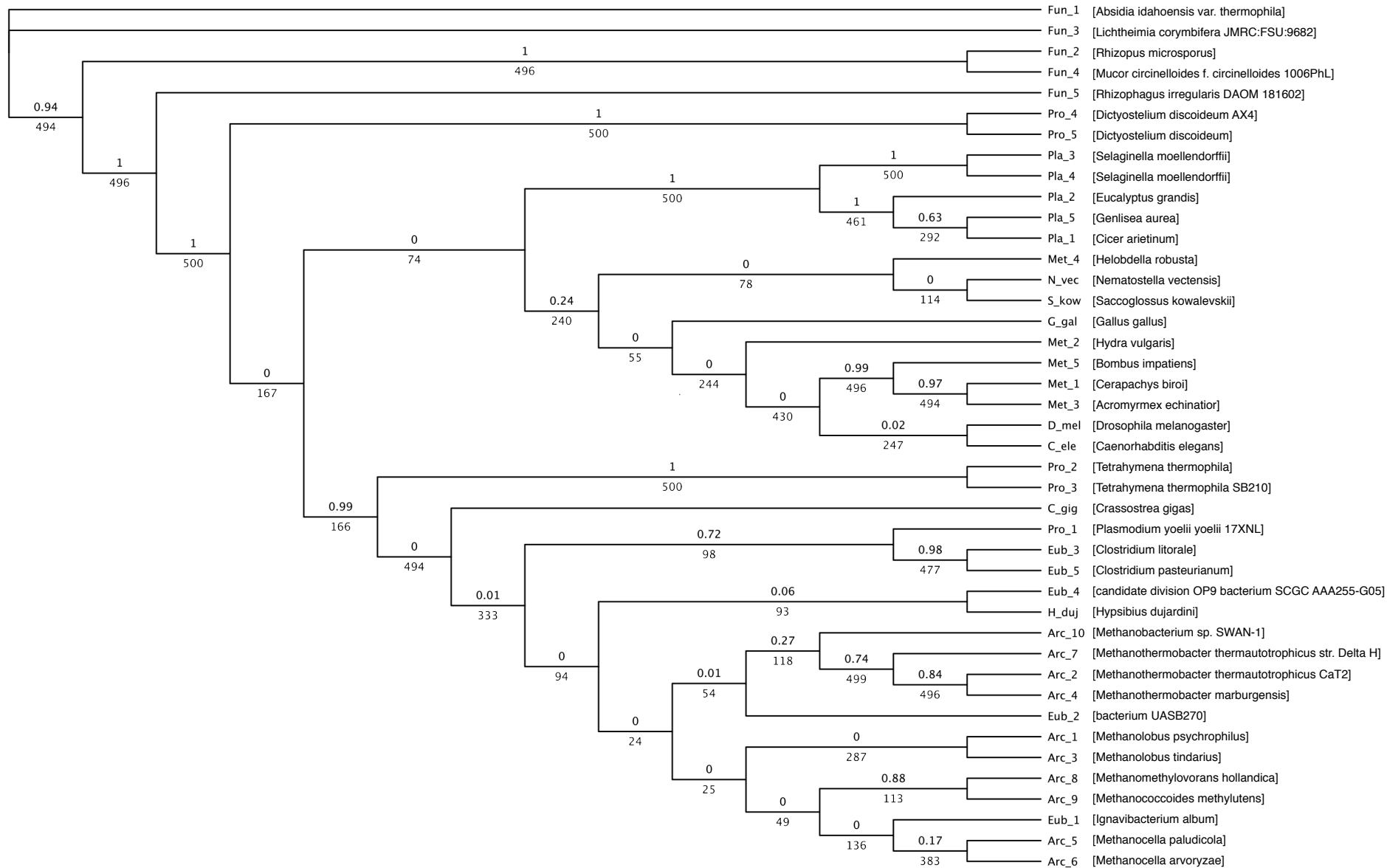

maker_scaffold3763_size17107_snap_gene_0.14

hypothetical protein ASPNIDRAFT_45025

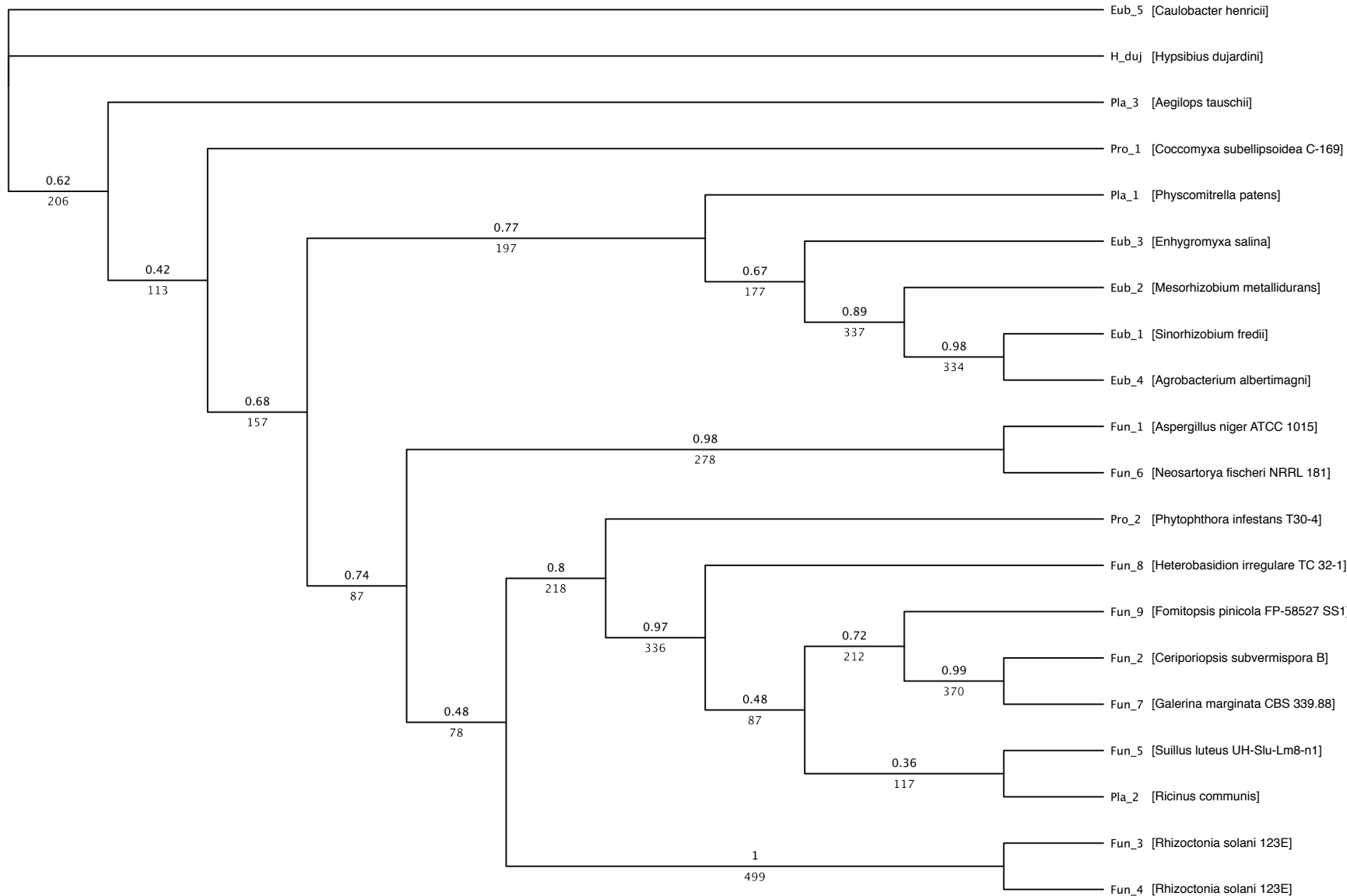

cyanate hydratase

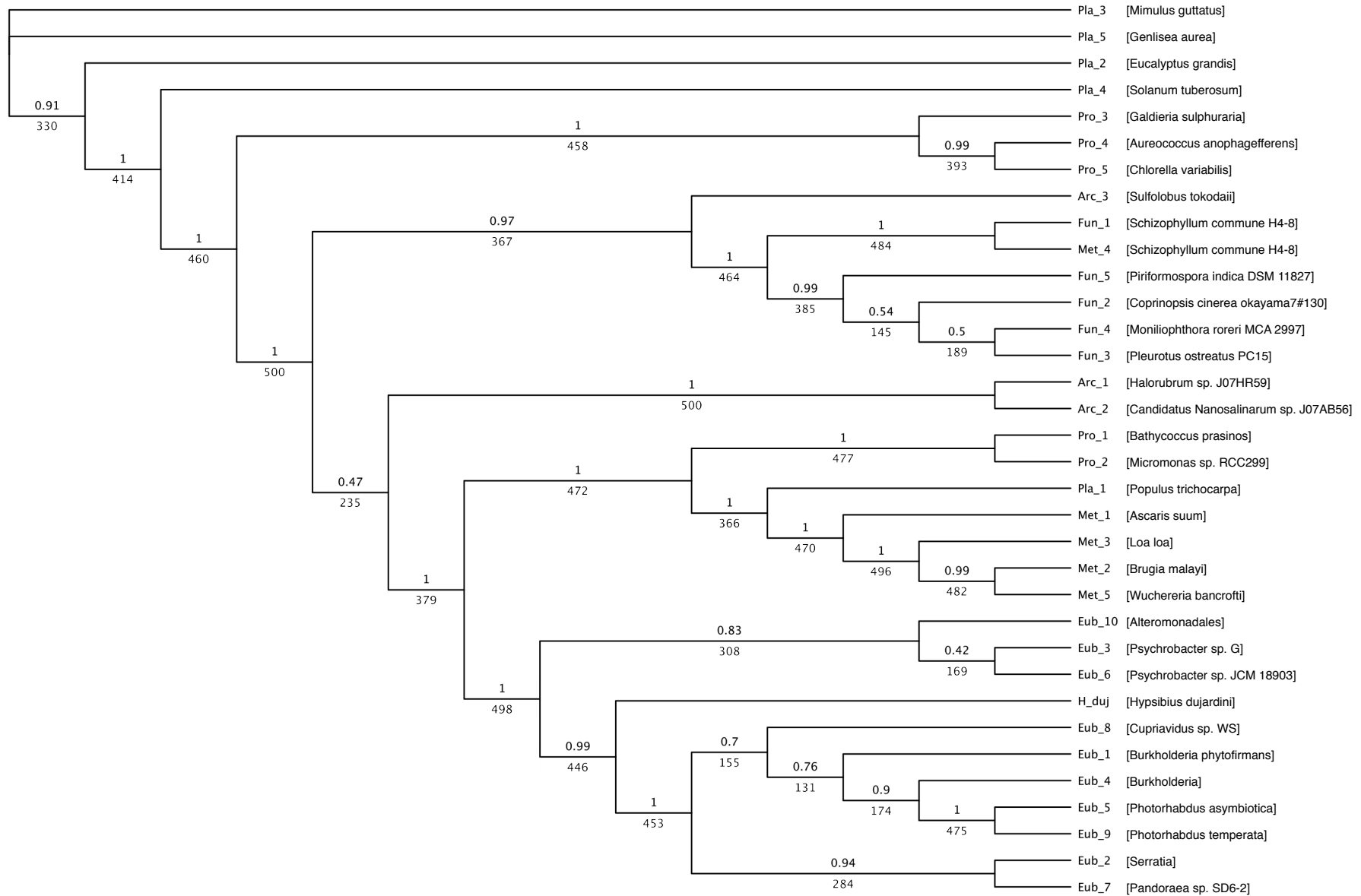

maker_scaffold3259_snap_gene_0.15

hypothetical protein mv_R860

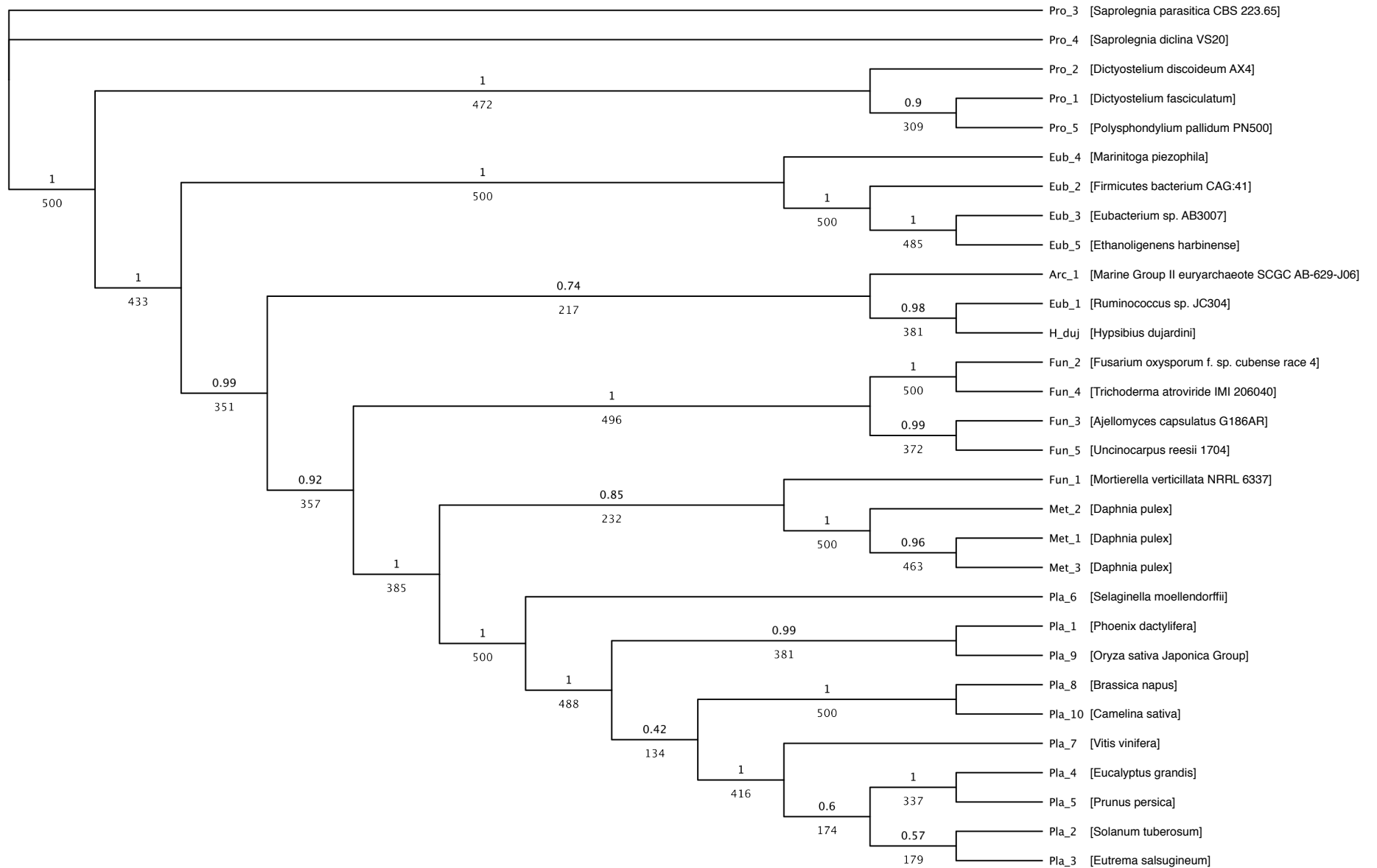

hypothetical protein

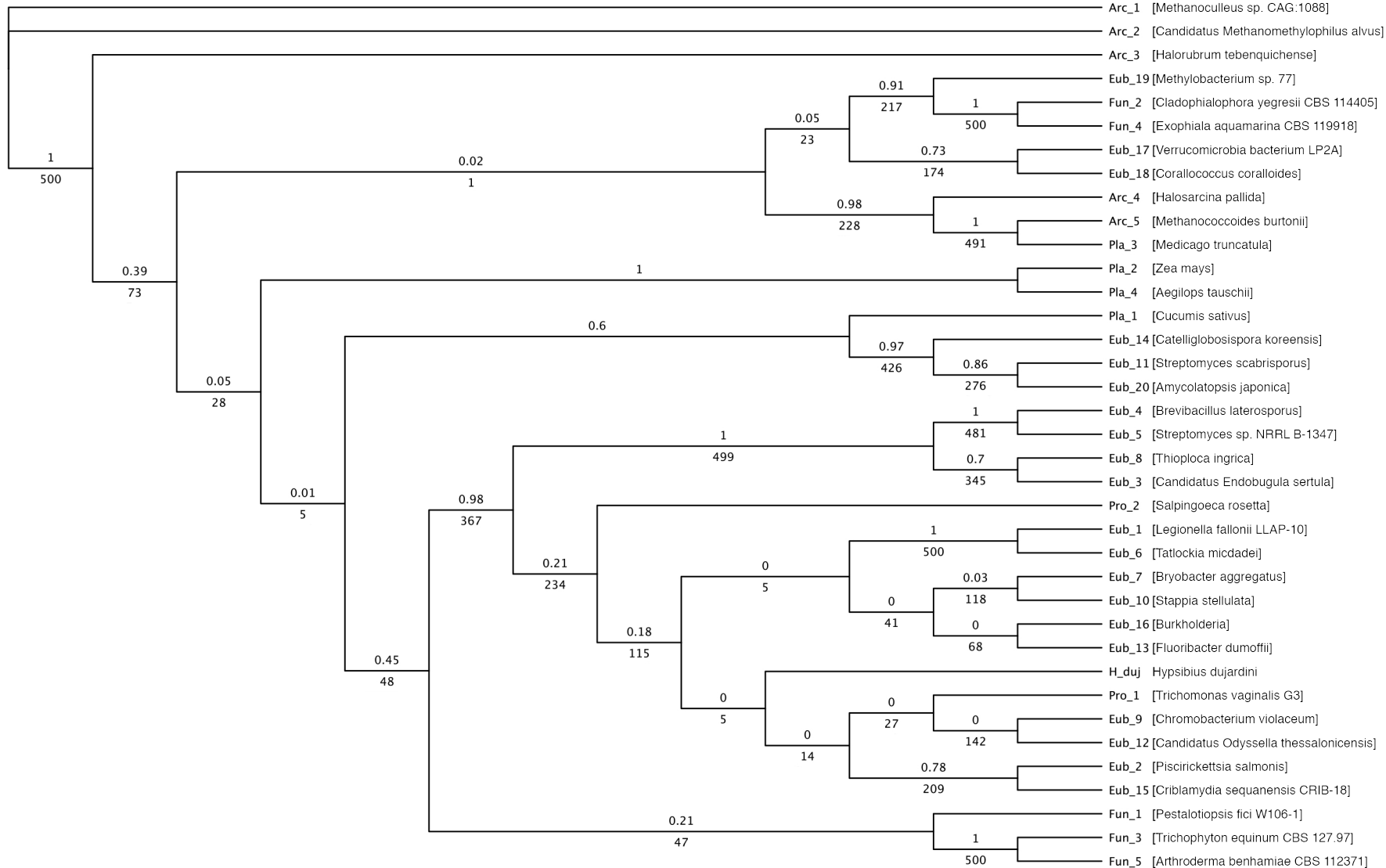

0.5

maker_scaffold3236_size18566_augustus_gene_0.14
hypothetical protein SELMODRAFT_266960

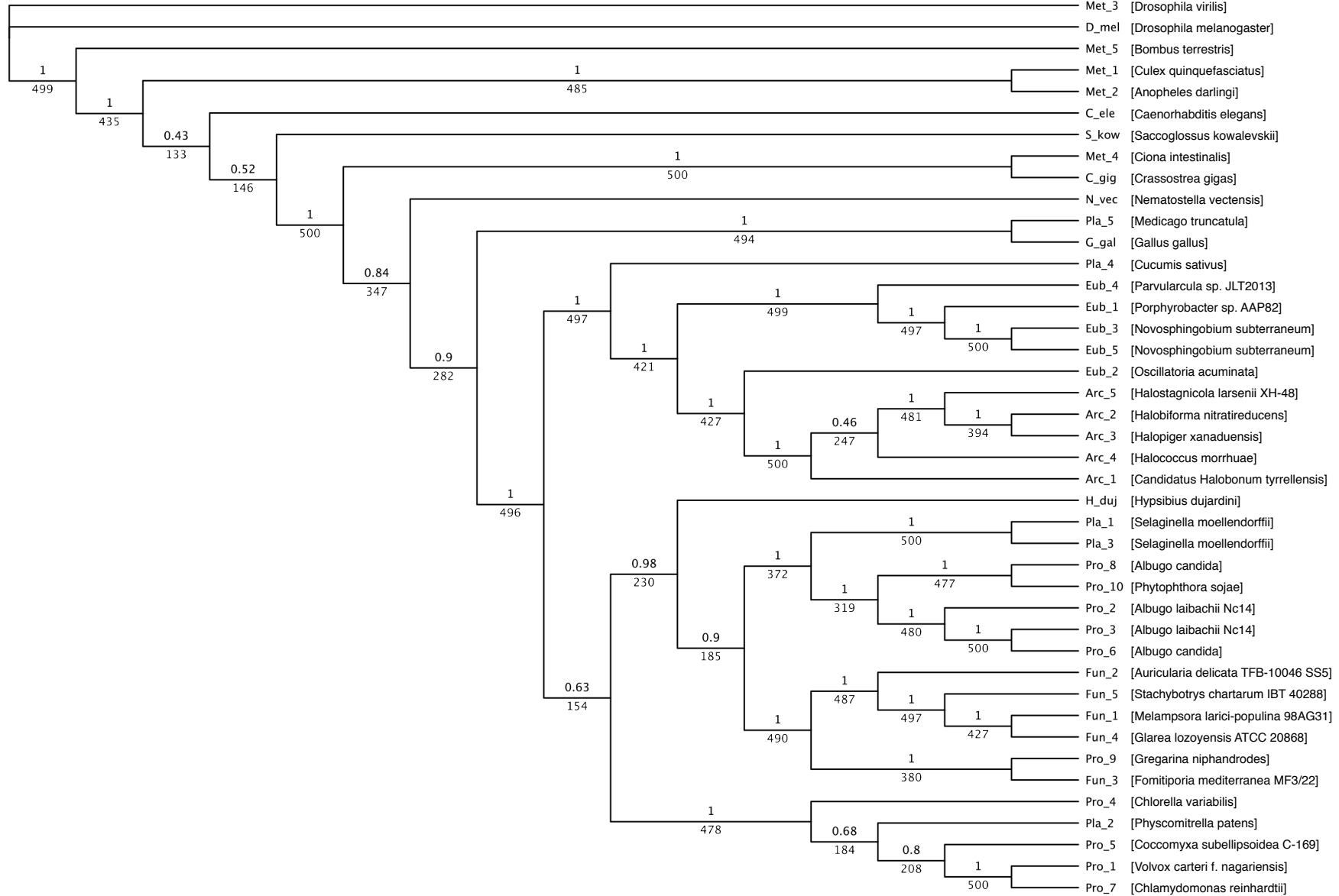

alpha/beta hydrolase

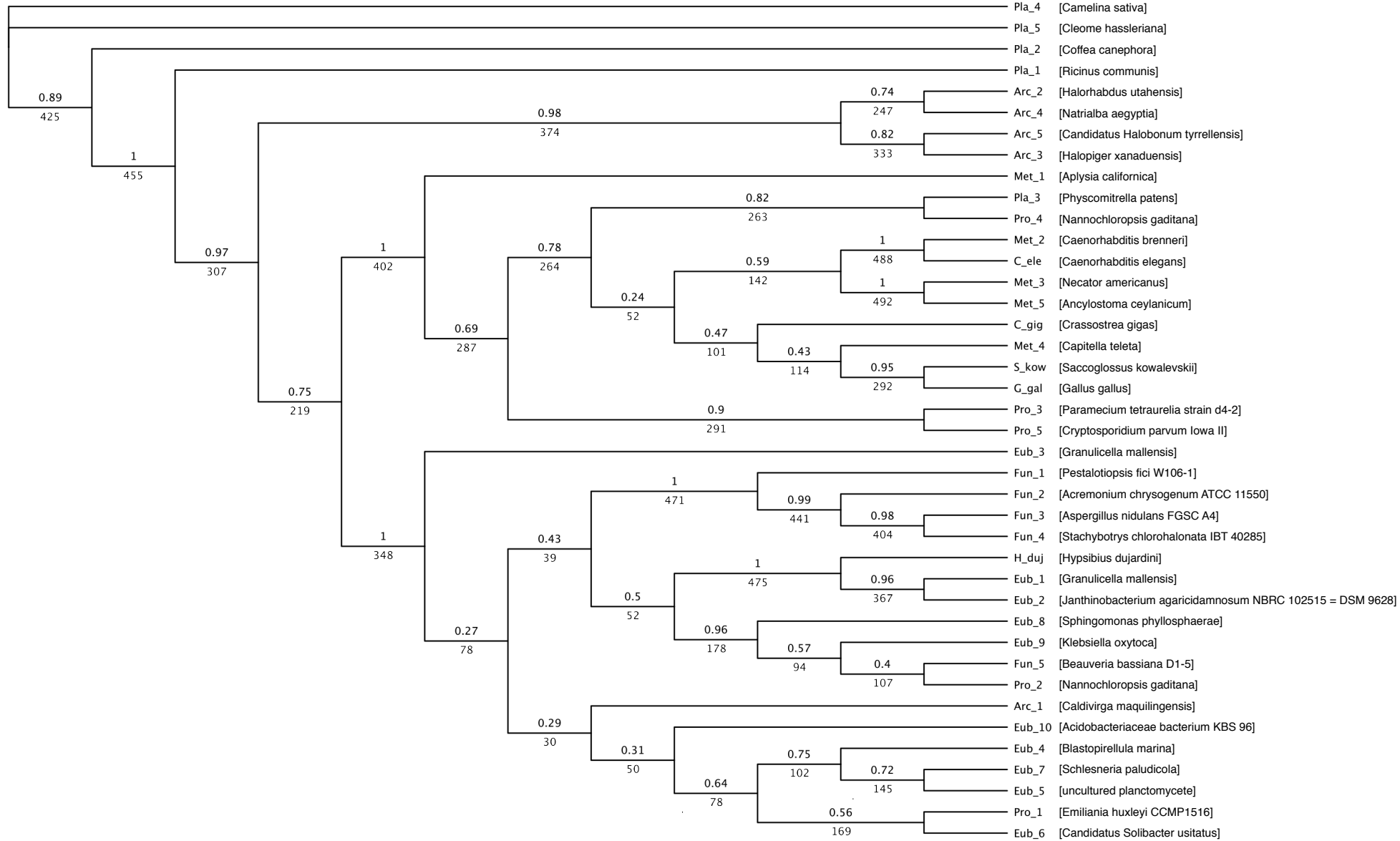

maker_scaffold1970_size23533_snap_gene_0.24

hypothetical protein RLEG12_03210

9

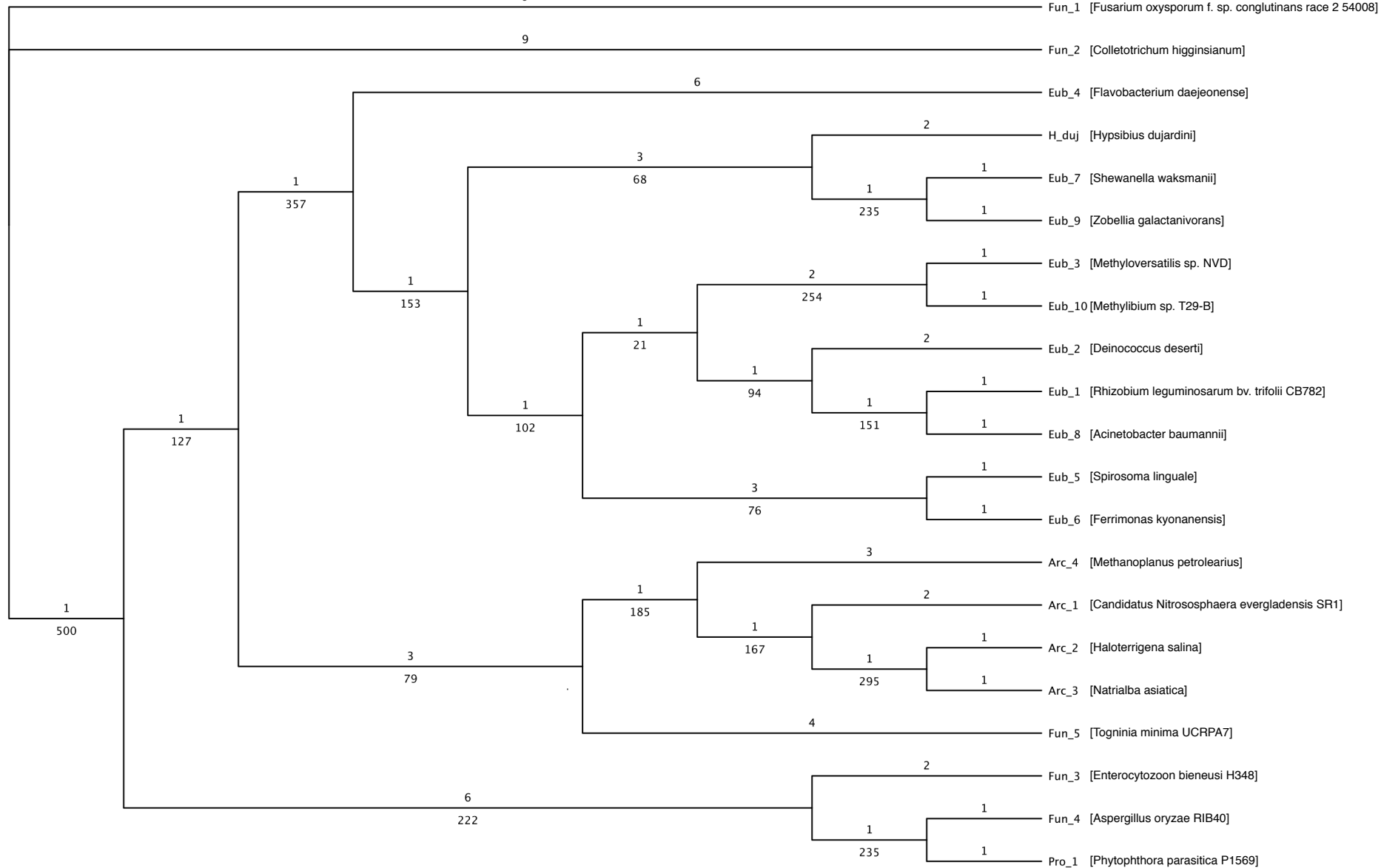

maker_scaffold1864_size33177_snap_gene_0.15

glycoside hydrolase family 3 protein

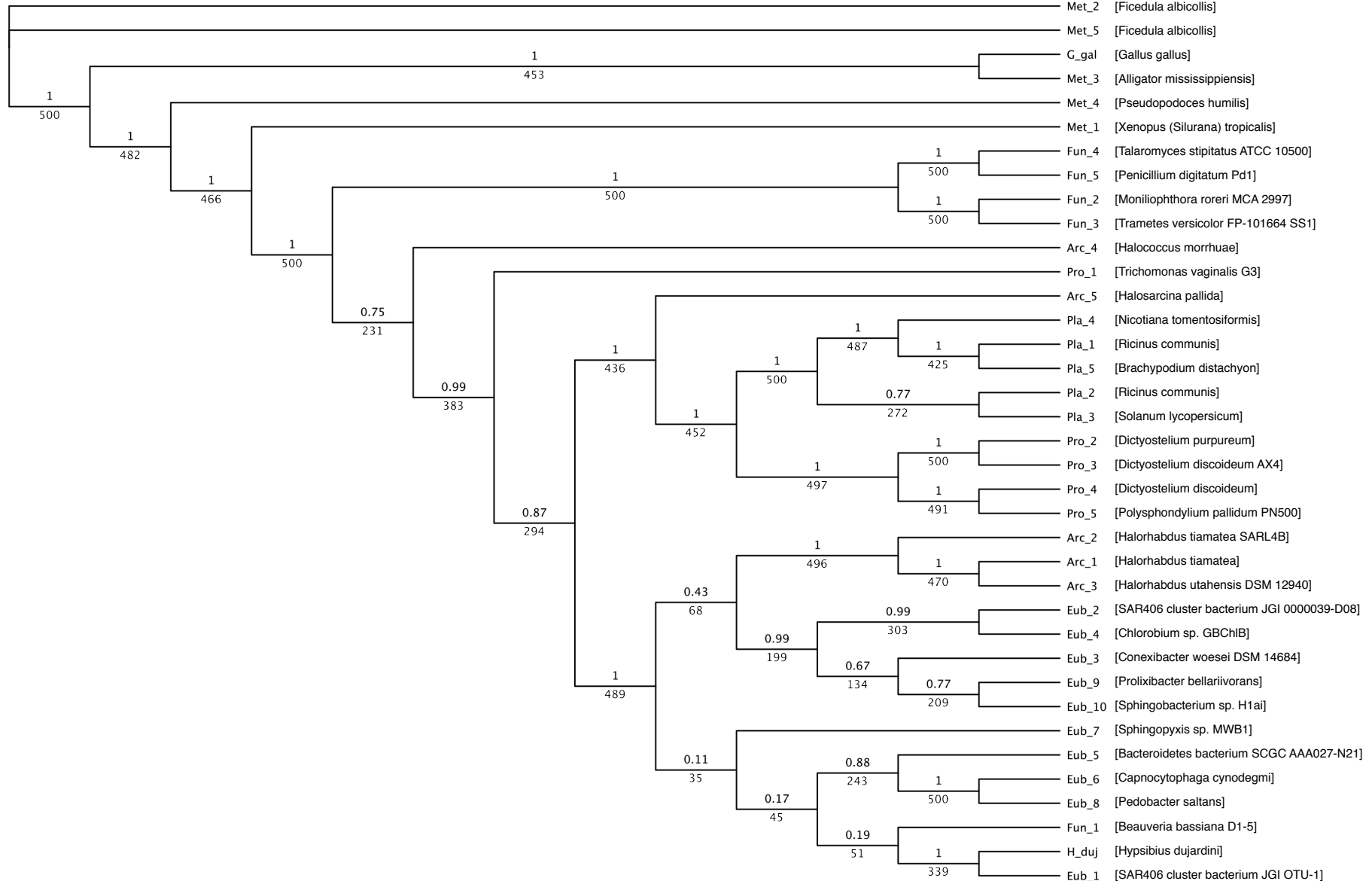

maker_scaffold1707_size25220_snap_gene_0.20

hypothetical protein Osl_22158

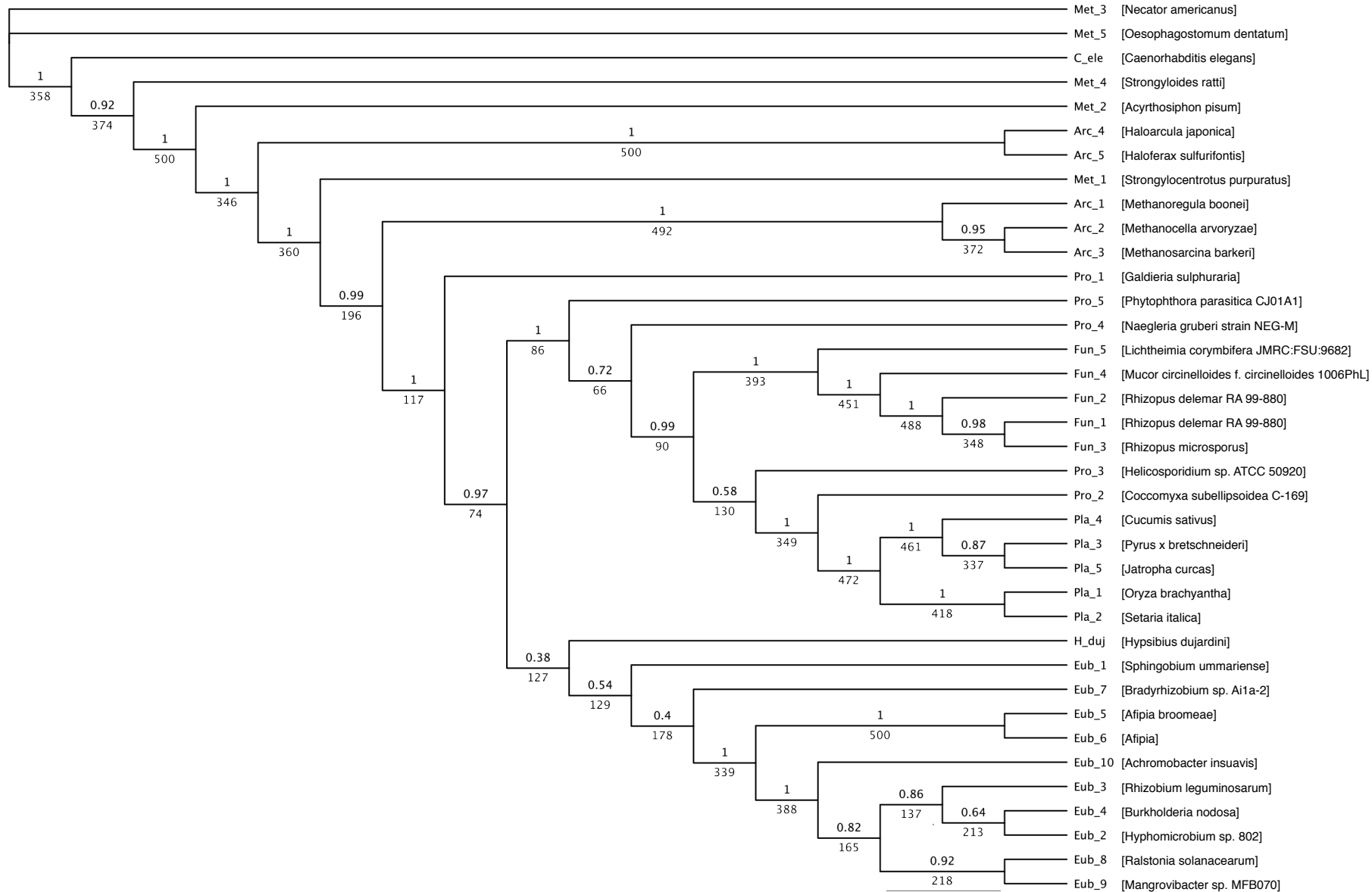

hypothetical protein

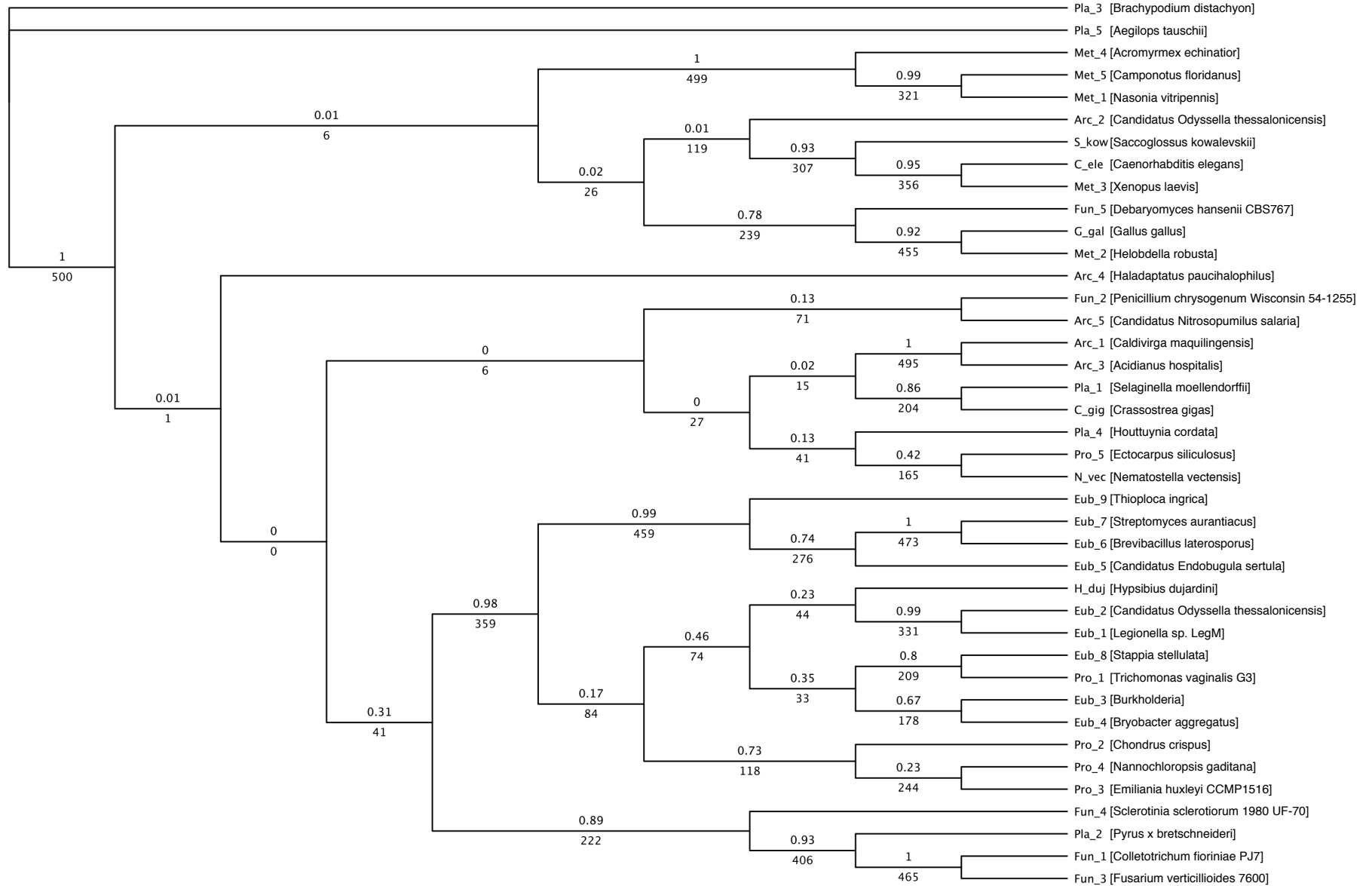

maker_scaffold1372_size1372_augustus_gene_0.18

hypothetical protein RLEG12_03210

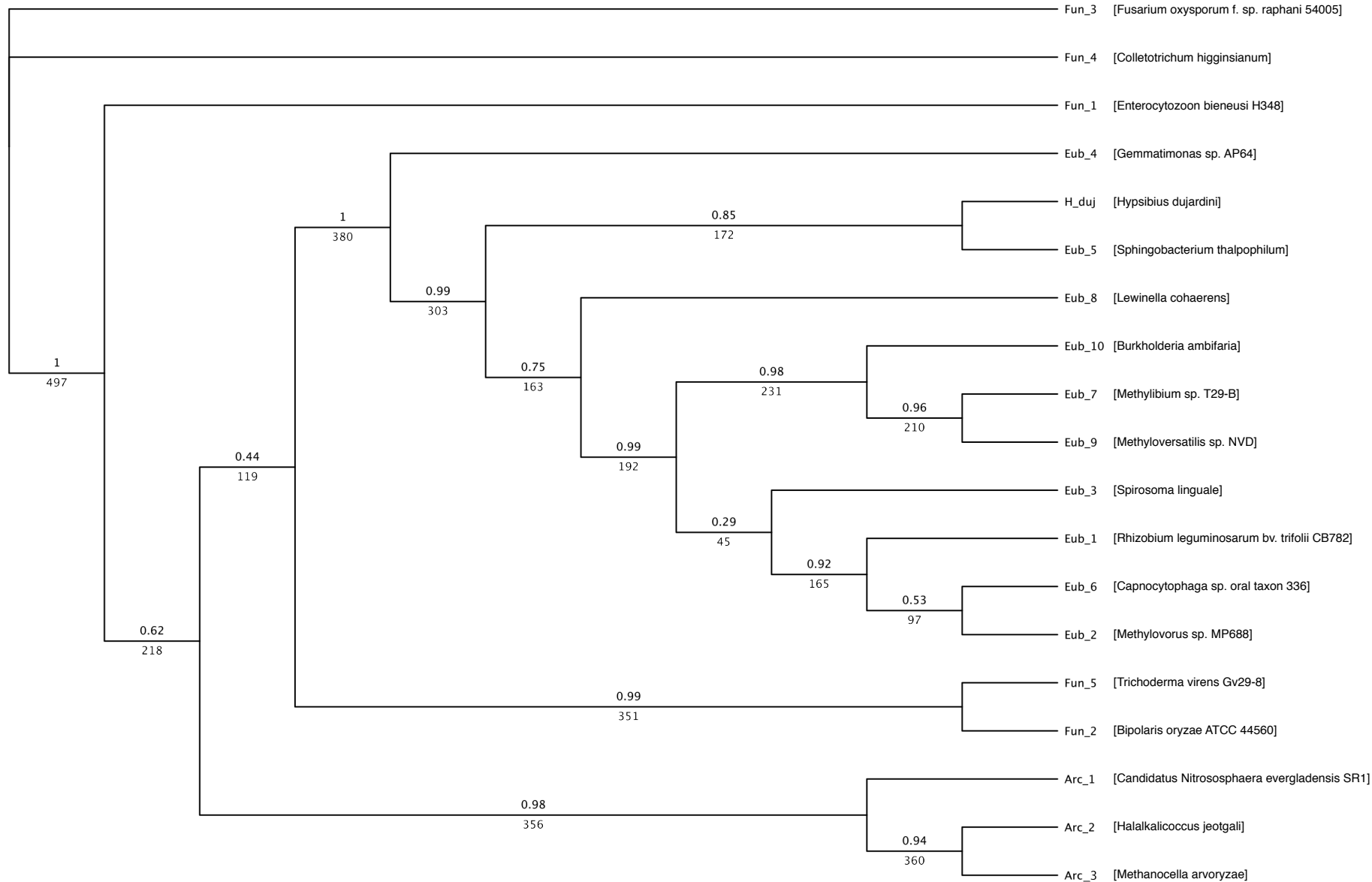

acetyl-CoA carboxylase subunit alpha

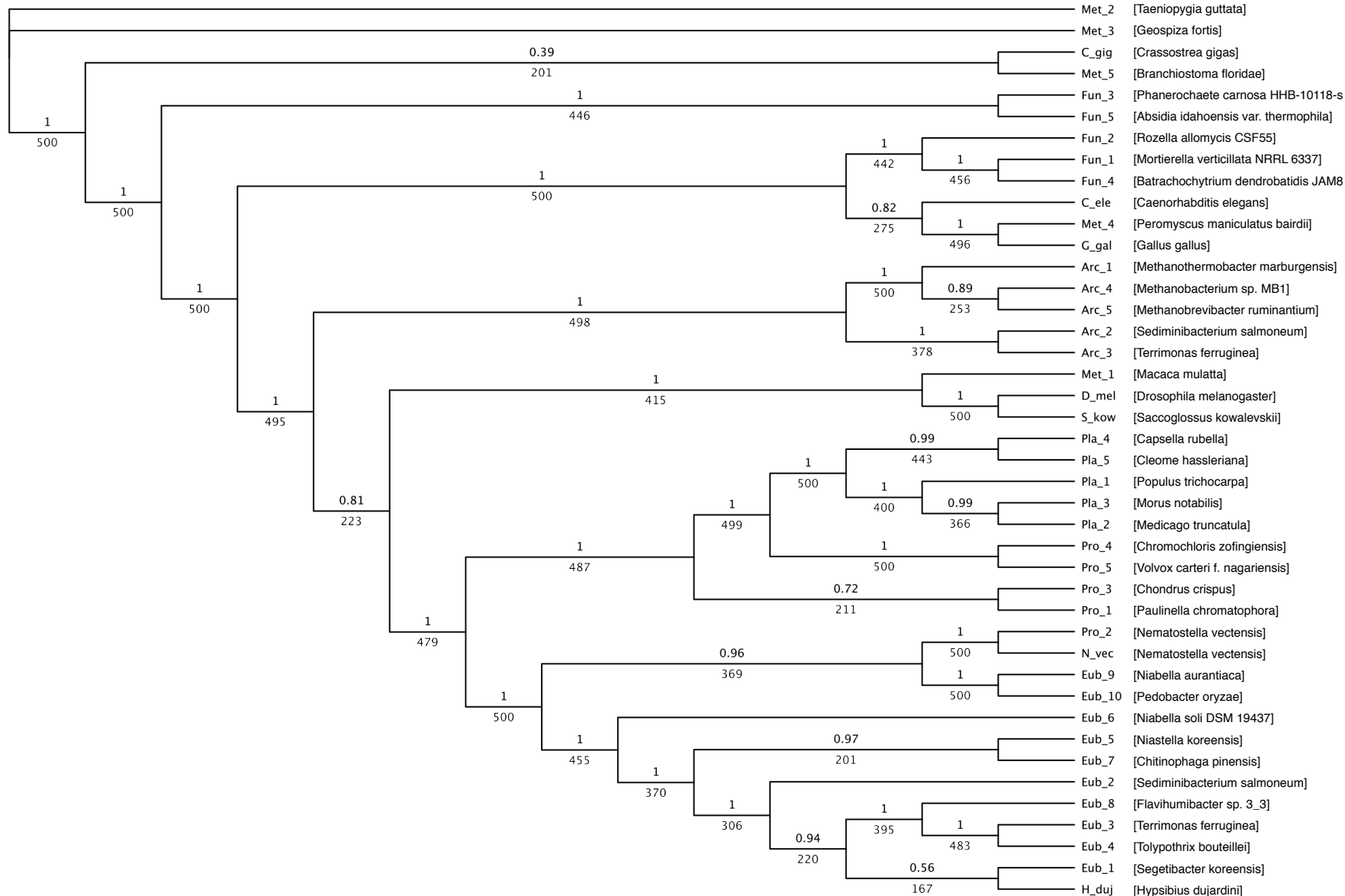

maker_scaffold1218_augustus_gene_0.15

hypothetical protein

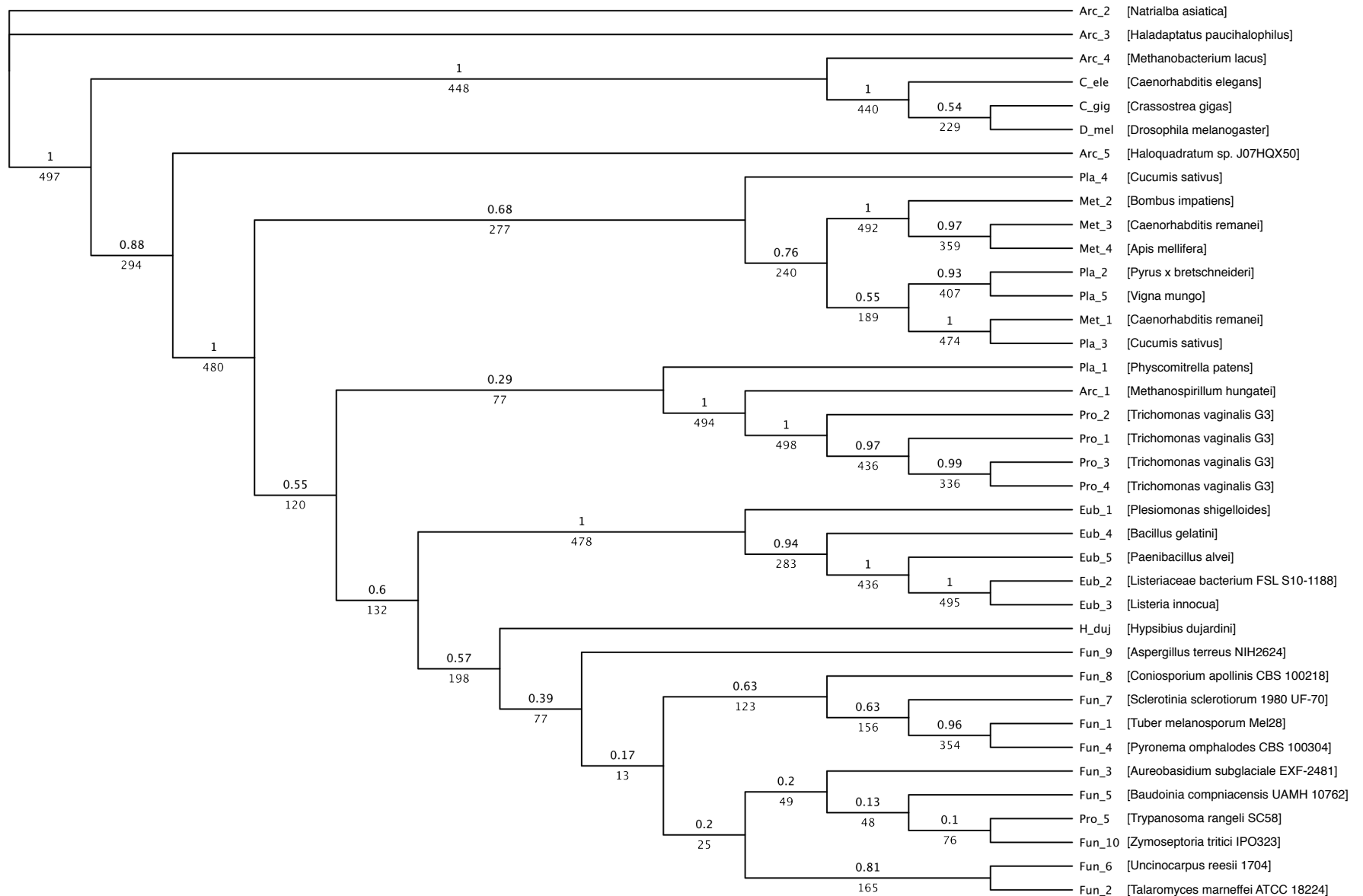

maker_scaffold1195_size29765_augustus_gene_0.13
hypothetical protein

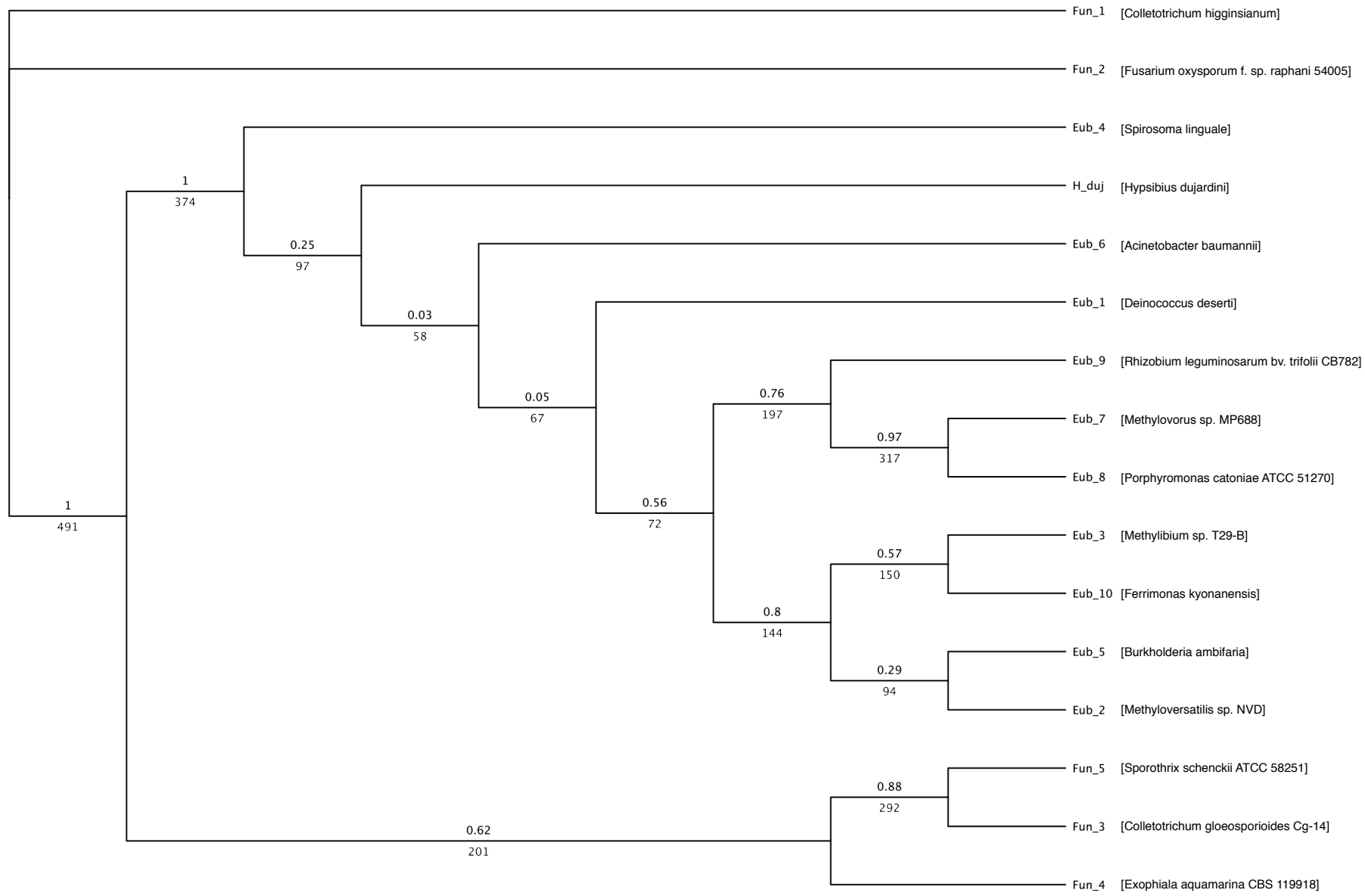

maker_scaffold1114_snap_gene_0.20
 hypothetical protein BATDEDRAFT_8747

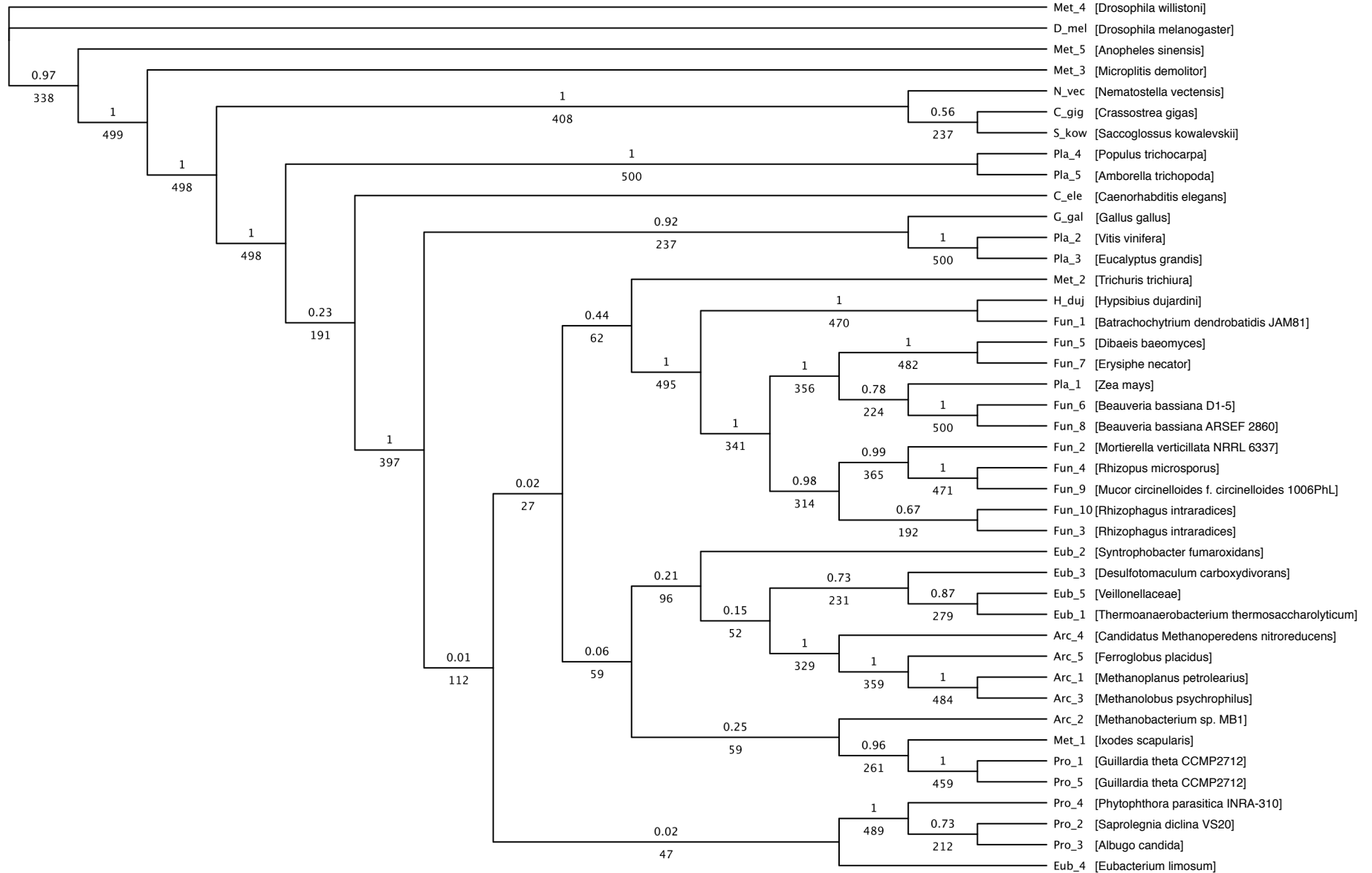

maker_scaffold1034_snap_gene_0.53
 ABC-type branched-chain amino acid transport syster

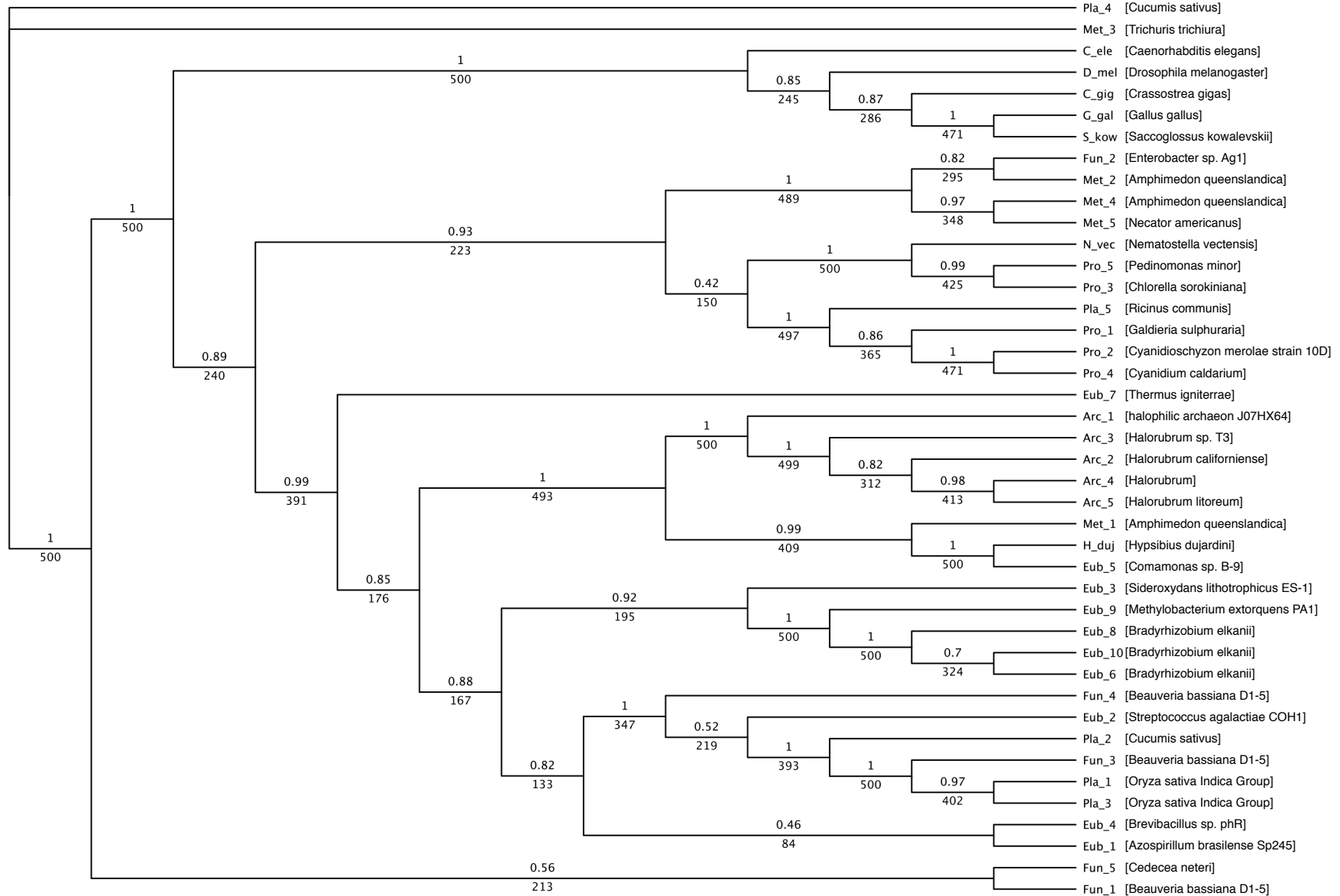

maker_scaffold962_size32525_snap_gene_0.37
DOPA-dioxygenase-related protein

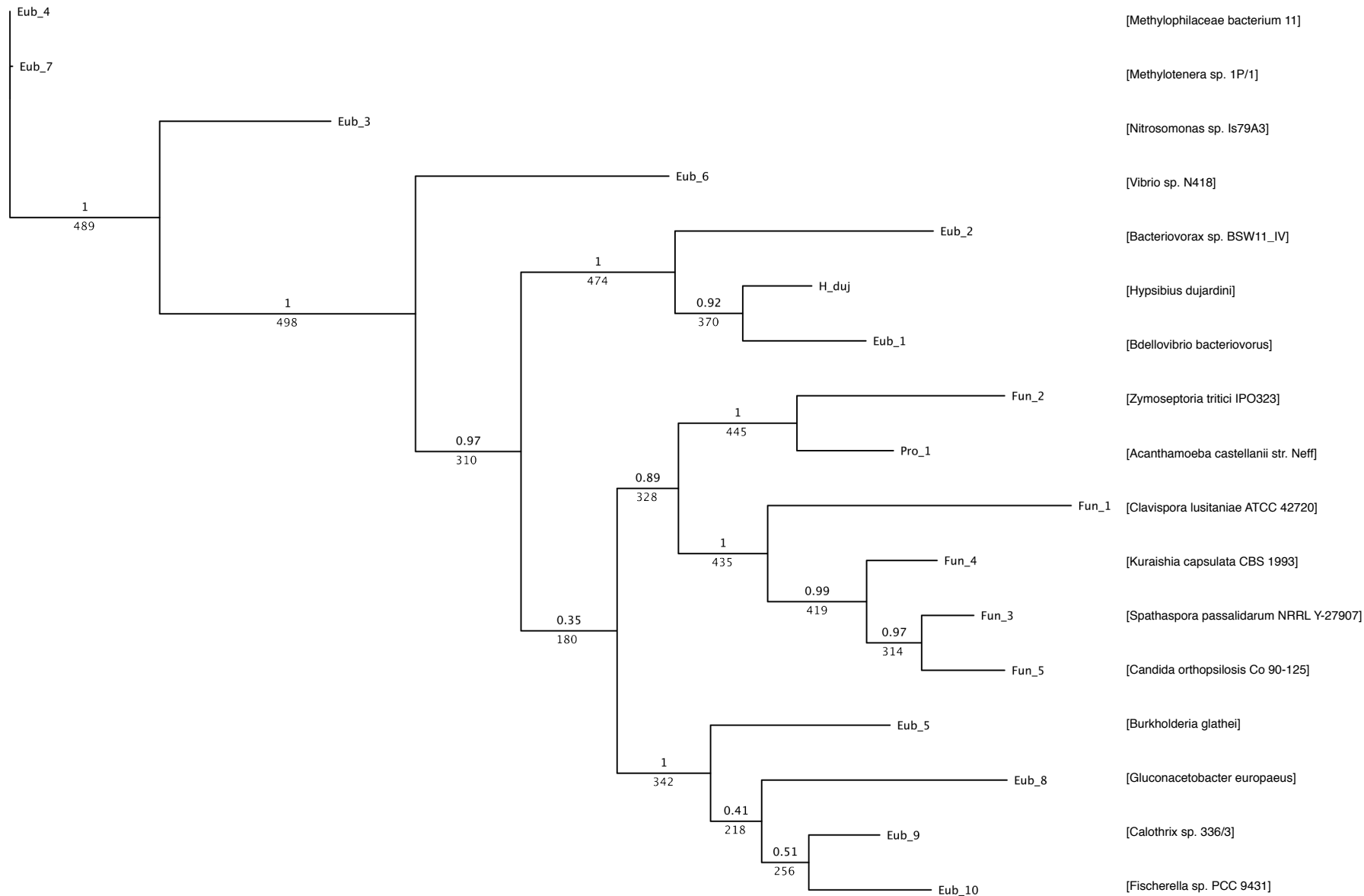

ABC transporter ATP-binding protein

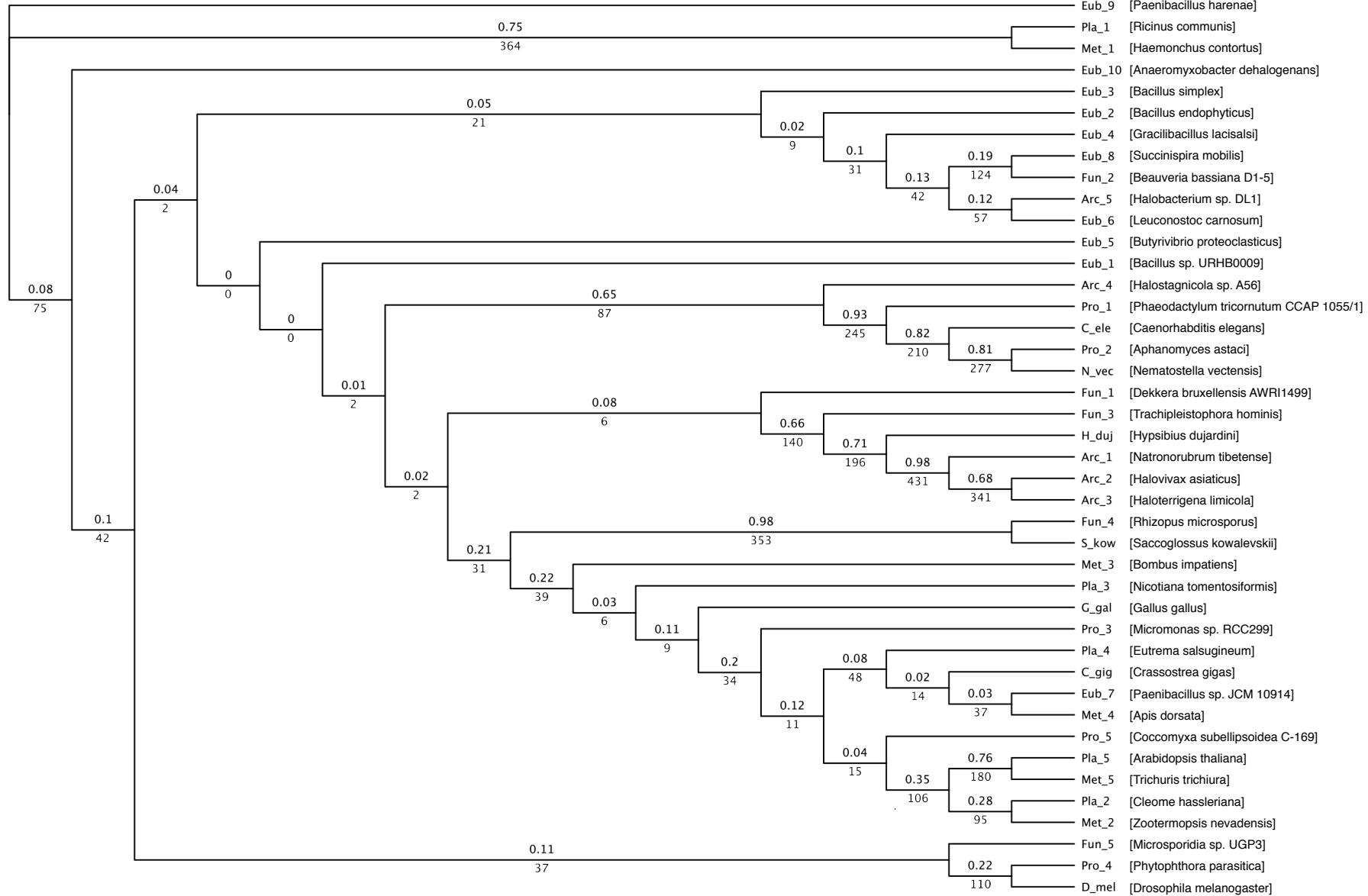

maker_scaffold749_size36498_snap_gene_0.17

Adenosylmethionine-8-amino-7-oxononanoate aminotransferase

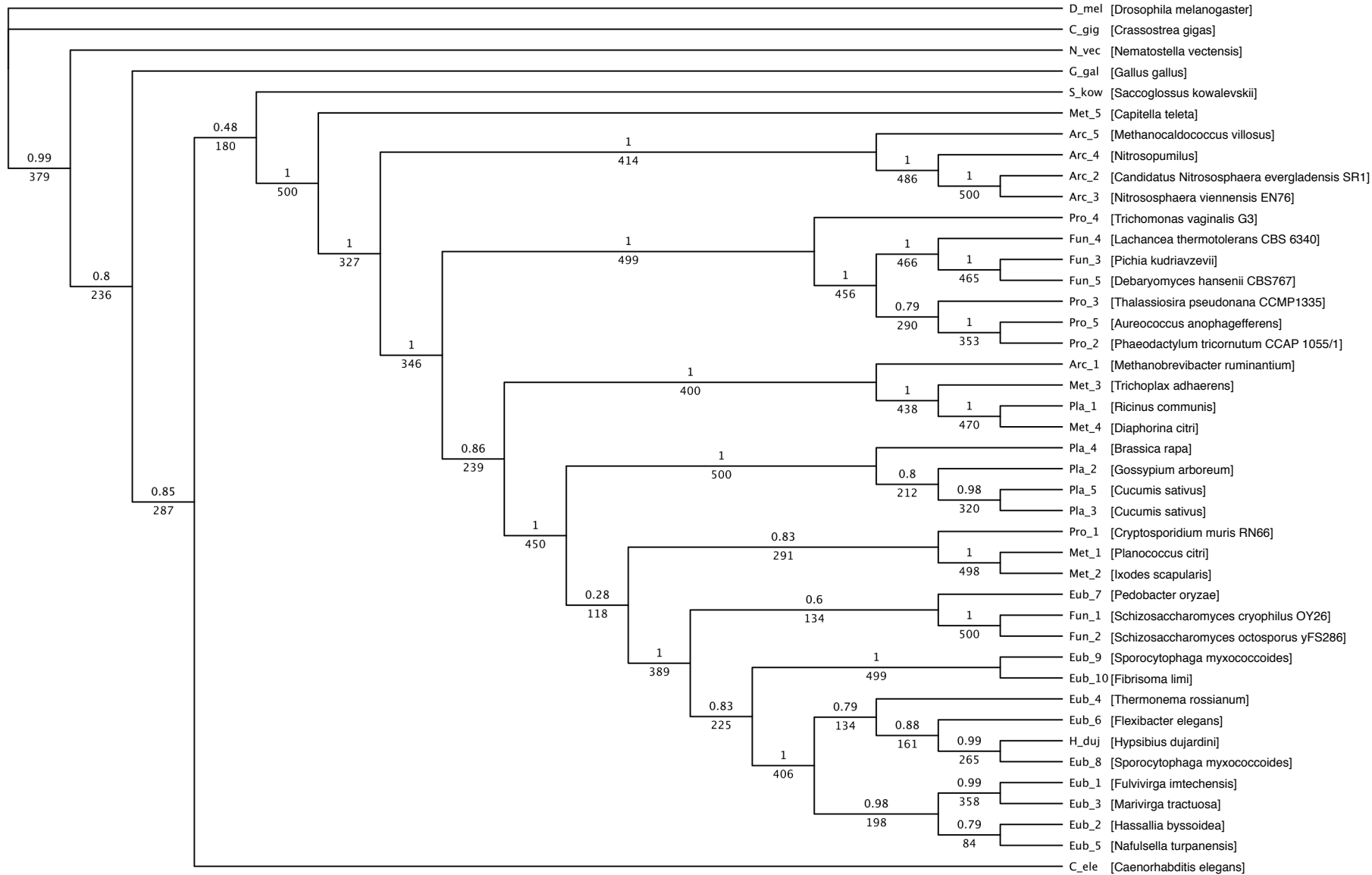

maker_scaffold741_size41061_snap_gene_0.36

cyanate hydratase

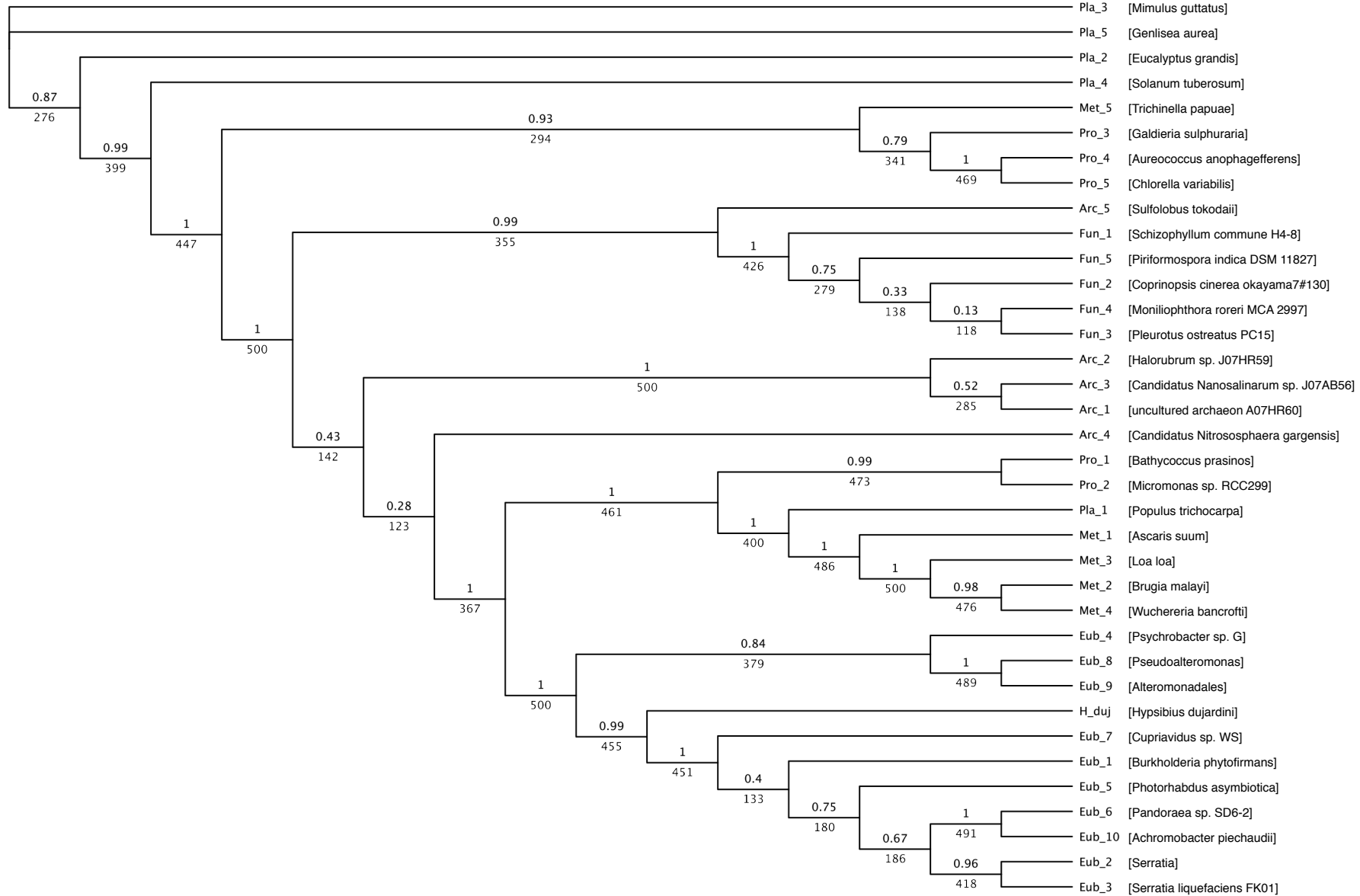

maker_scaffold714_size37228_augustus_gene_0.11

acetylglucosaminyltransferase/ transferase

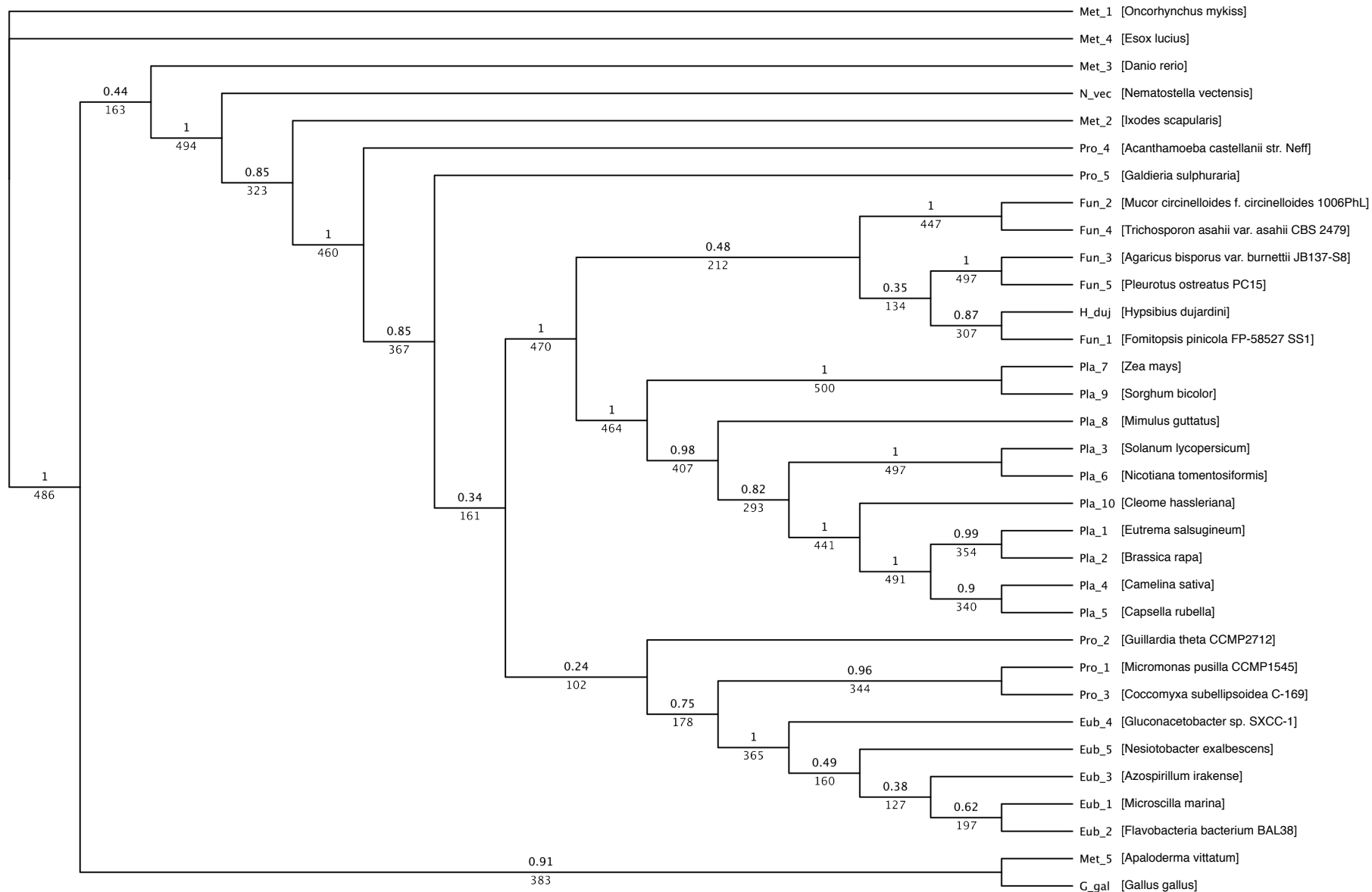

maker_scaffold668_size38133_augustus_gene_0.18

hypothetical protein

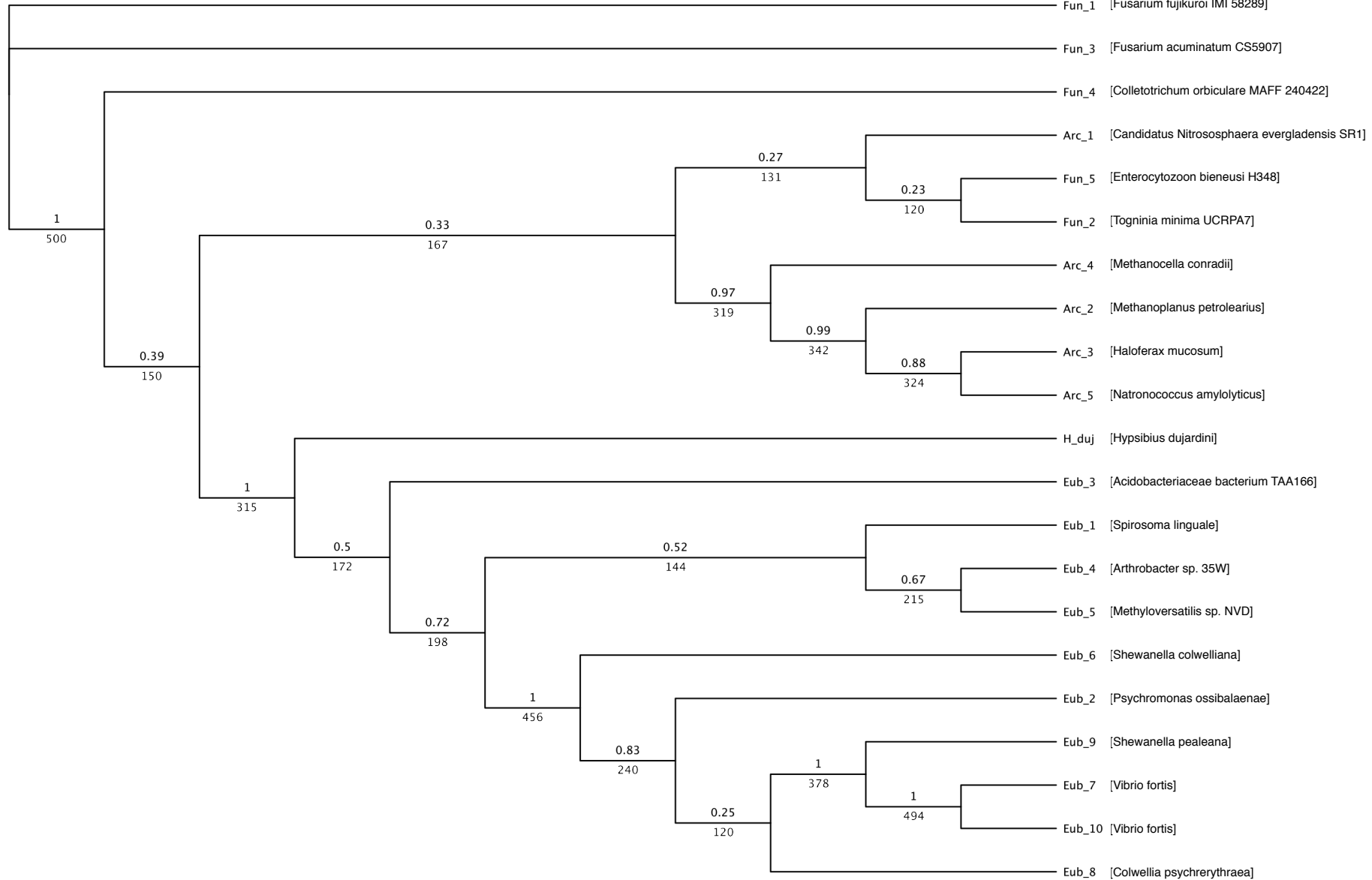

maker_scaffold653_size38539_augustus_gene_0.27

PREDICTED: crocetin glucosyltransferase, chloroplastic-like

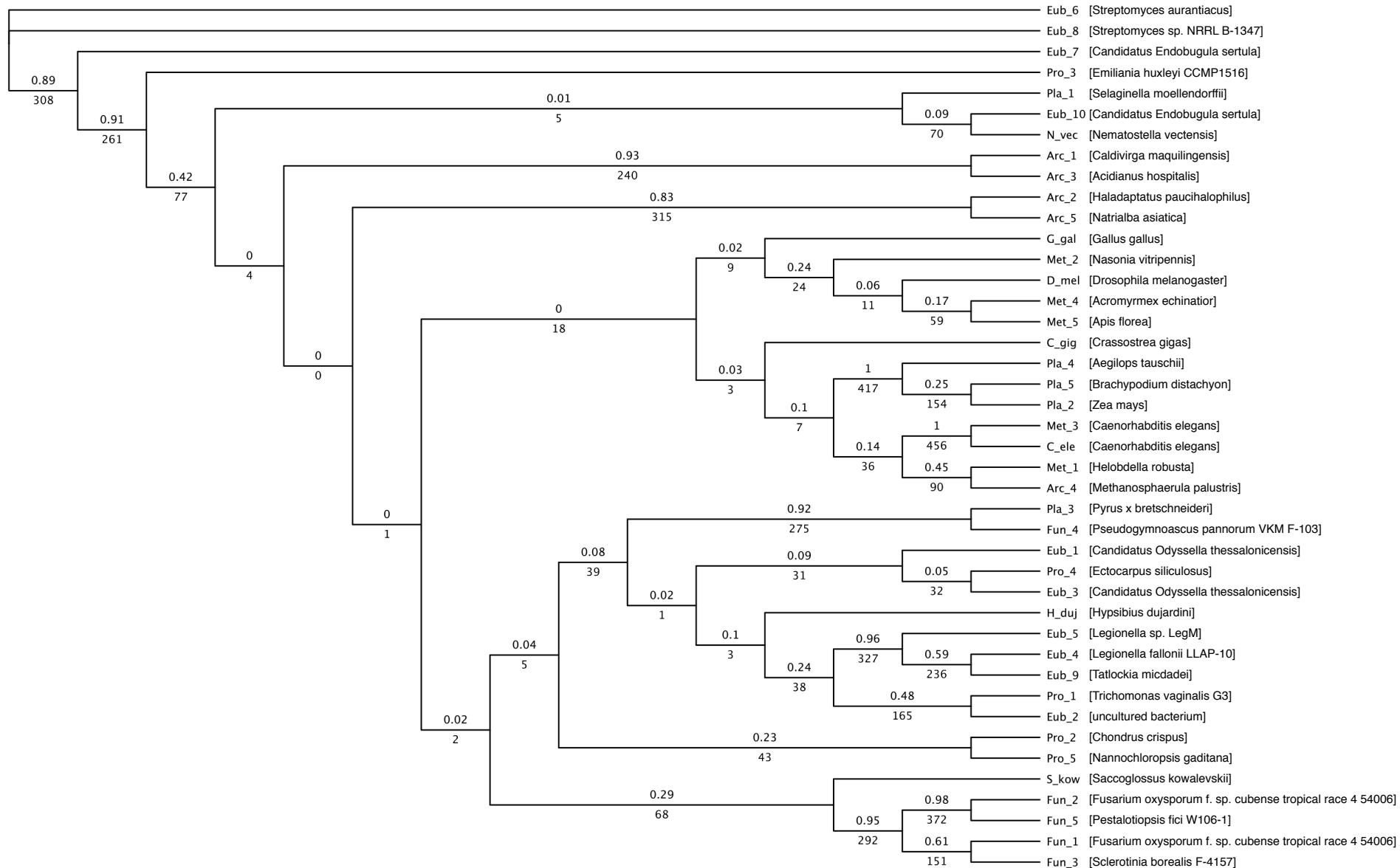

glycoside hydrolase family 43

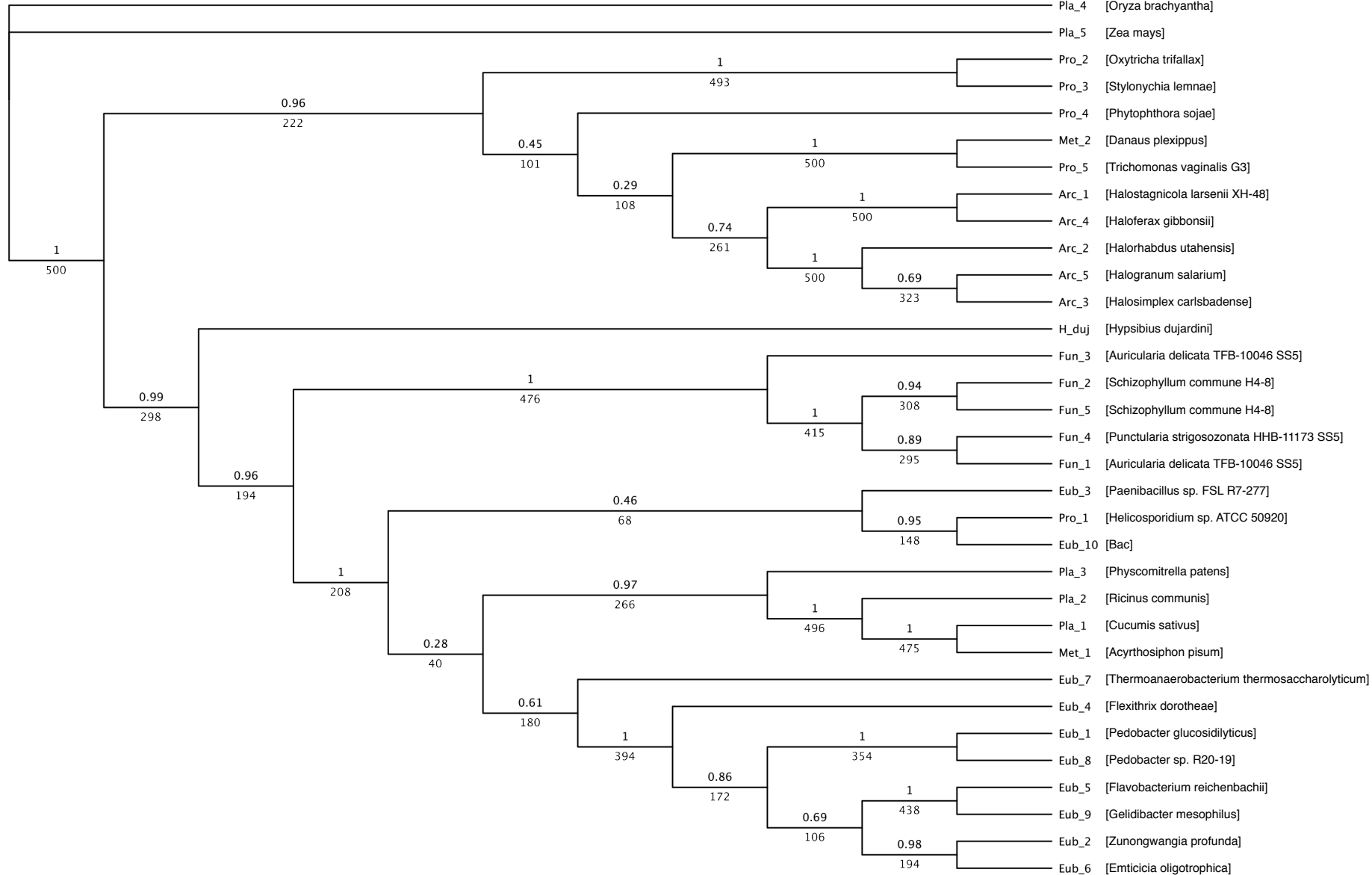

maker_scaffold505_size42588_augustus_gene_0.26

hypothetical protein BATDERAFT_8747

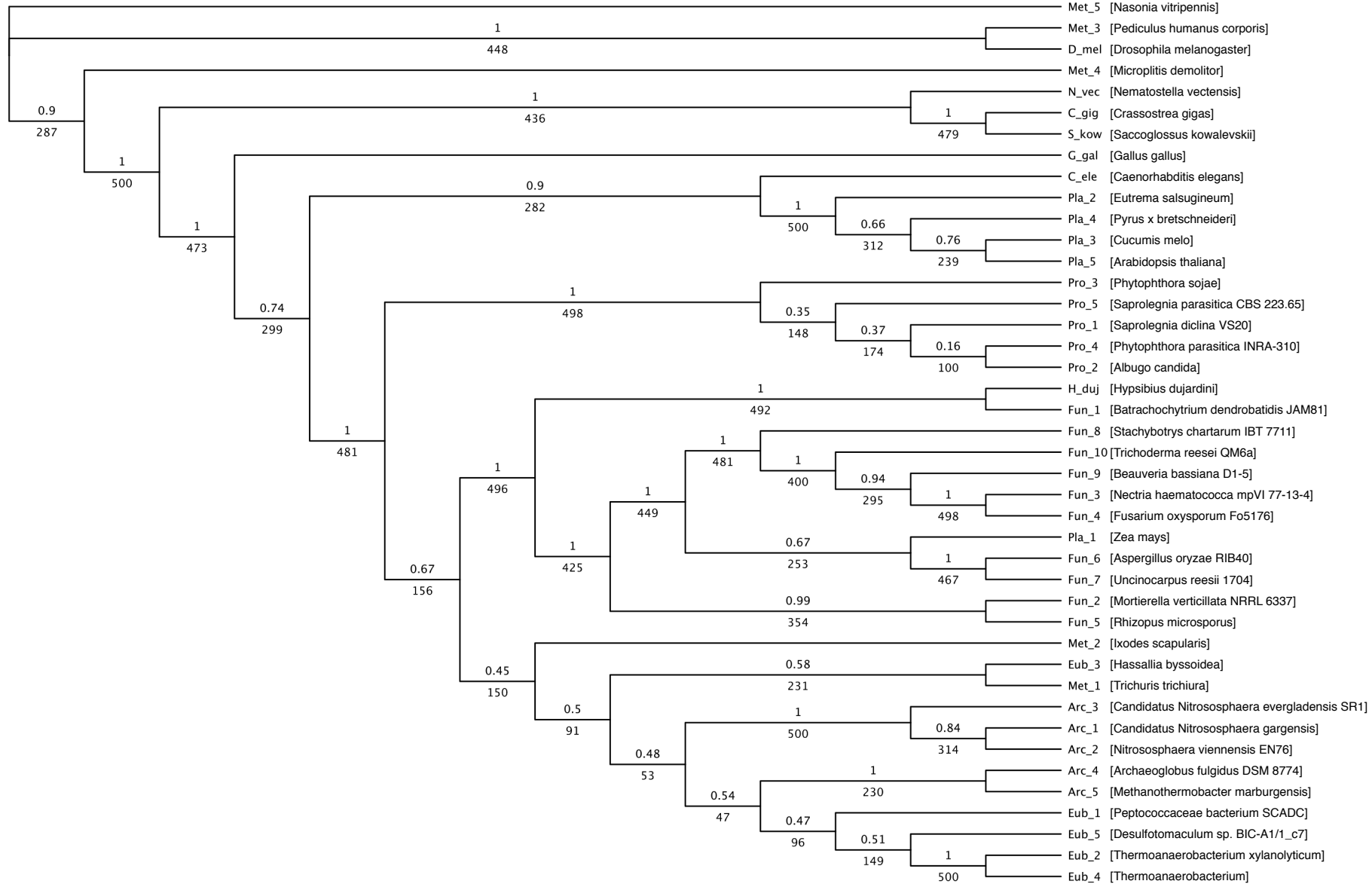

hypothetical protein mv_R860

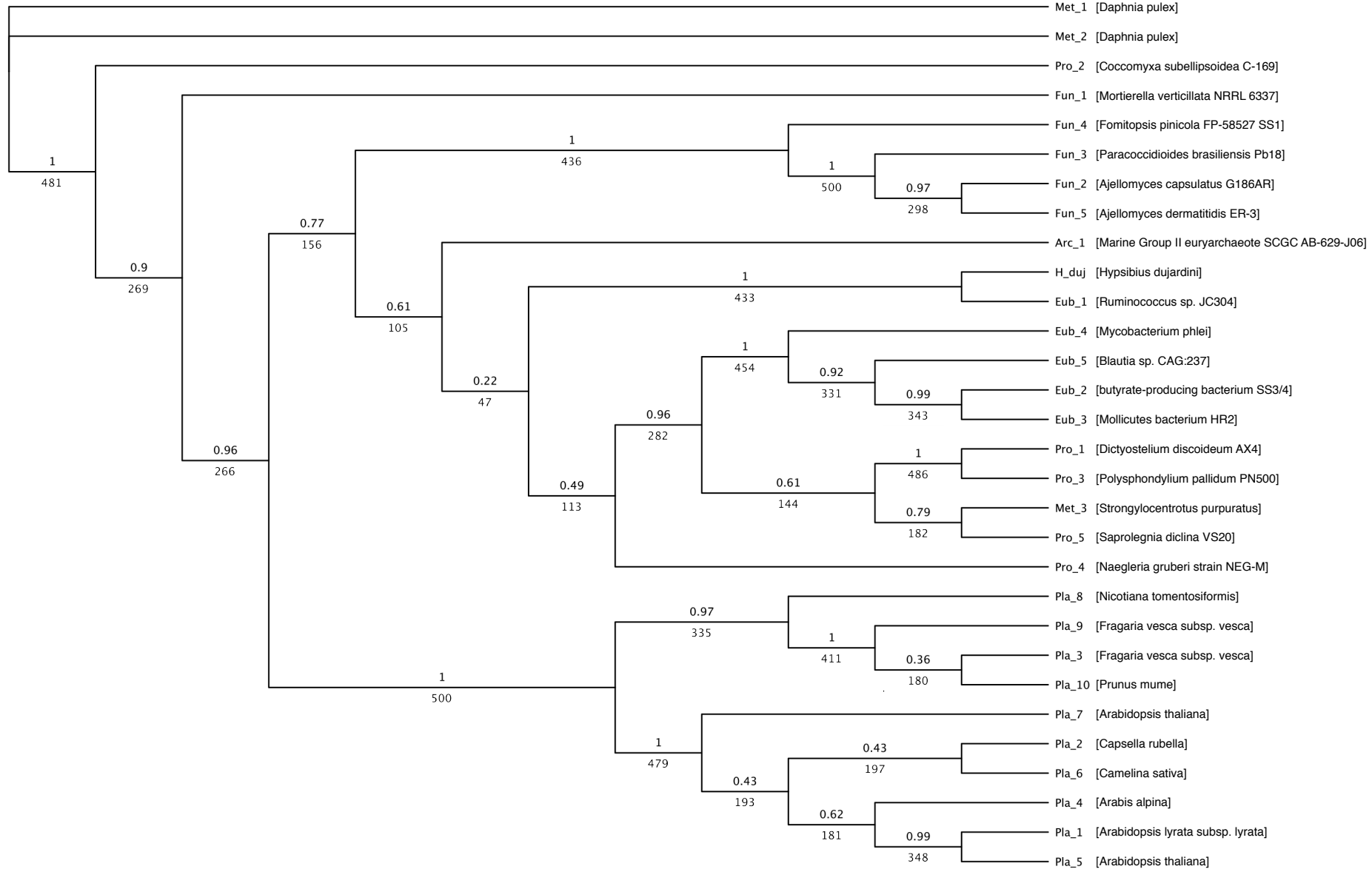

maker_scaffold301_size53378_augustus_gene_0.28

hypothetical protein

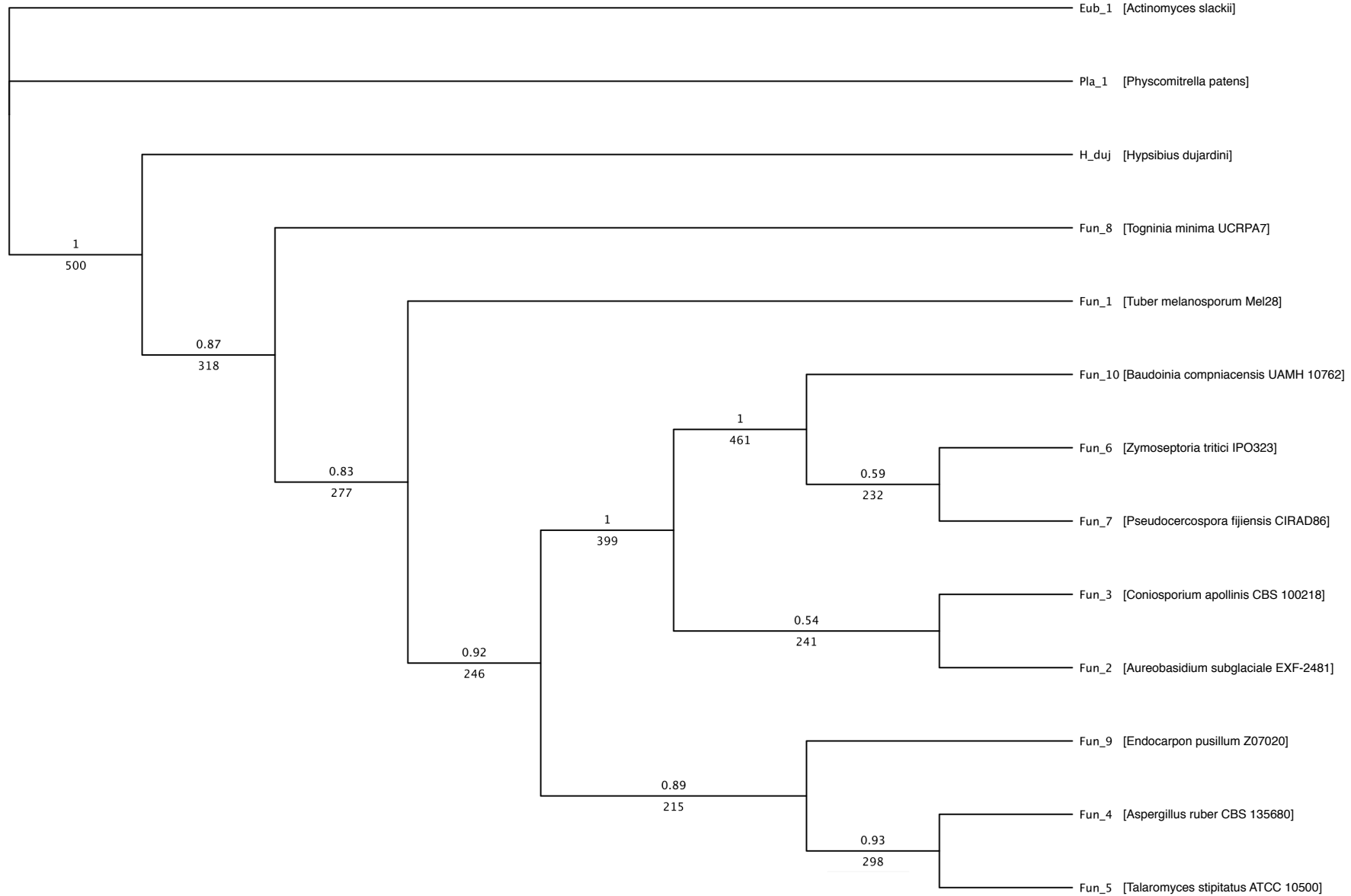

maker_scaffold117_augustus_gene_0.84

molybdenum ABC transporter permease

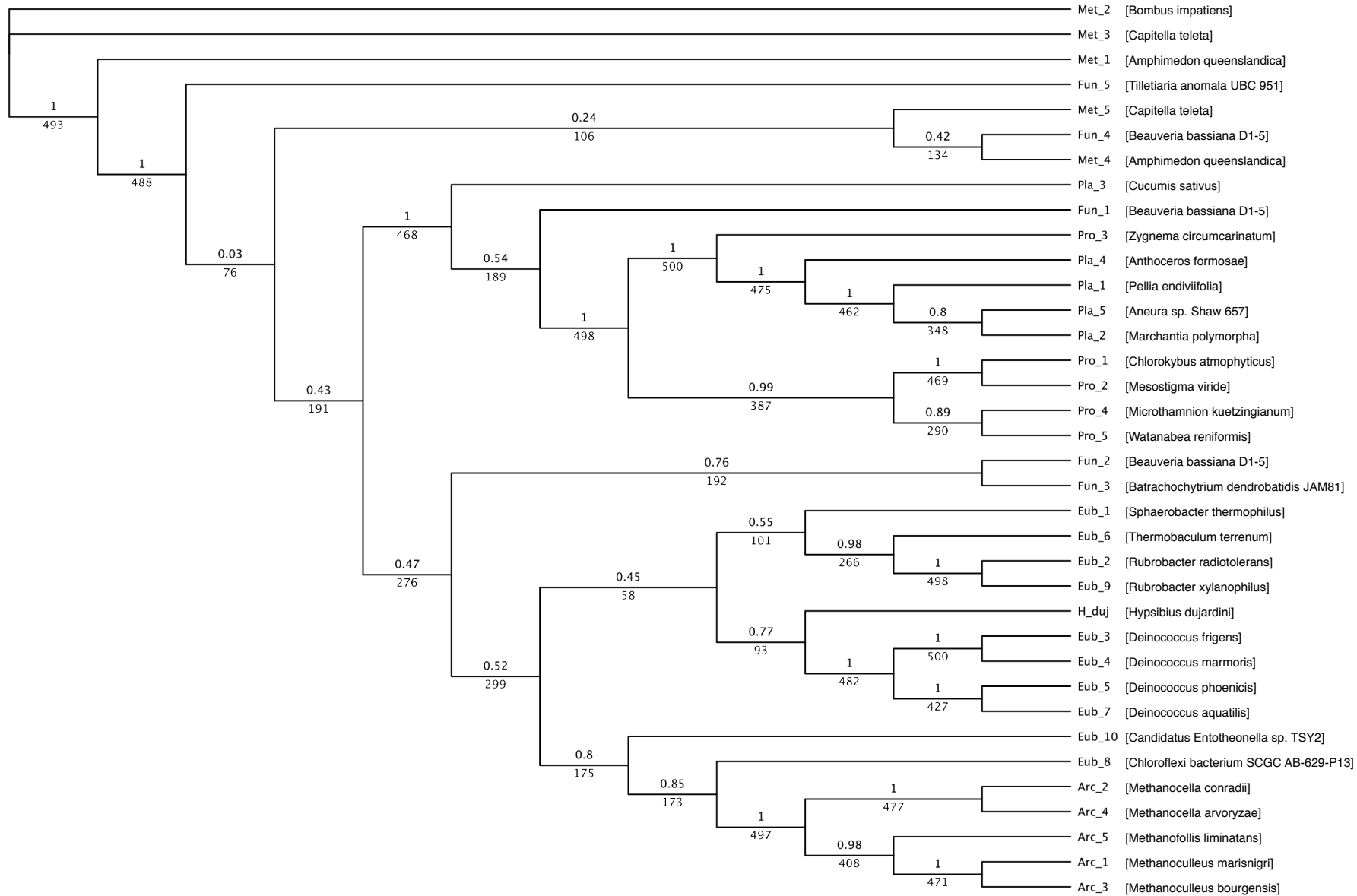

maker_scaffold115_snap_gene_0.80
peptide ABC transporter ATPase

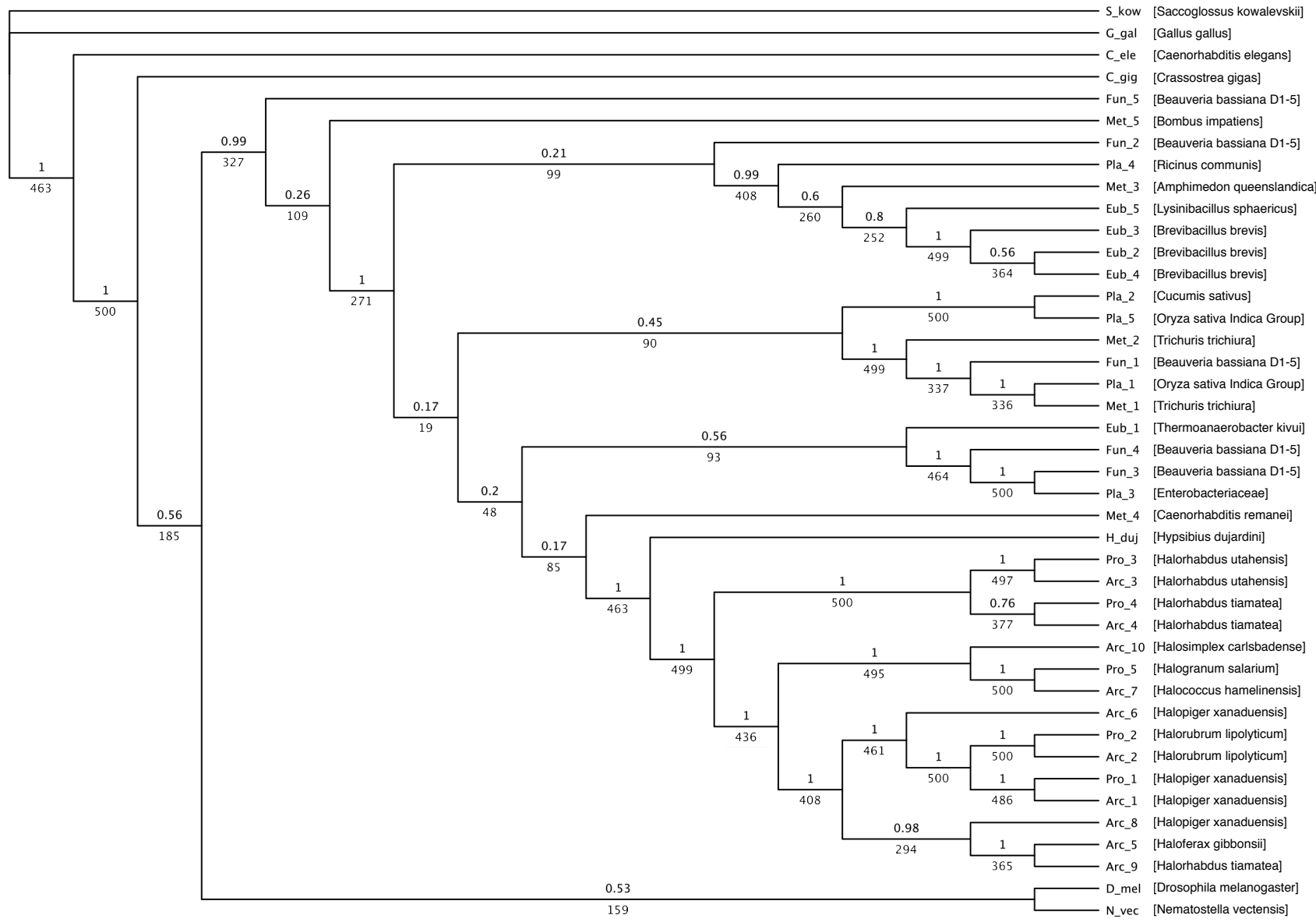

maker_scaffold104_augustus_gene_0.25

hypothetical protein RirG_114100

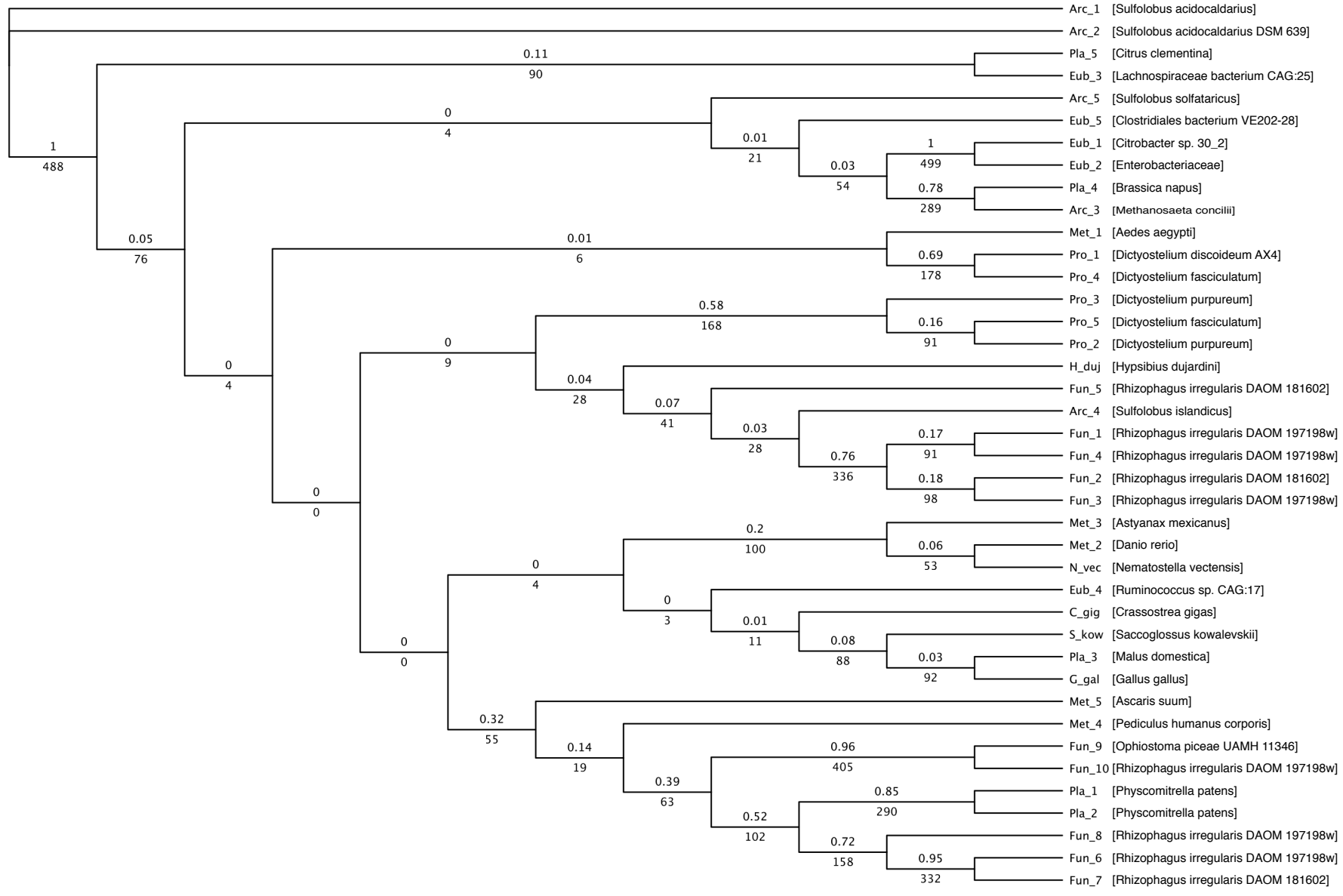

maker_scaffold100_snap_gene_0.59
hypothetical protein RirG_080310

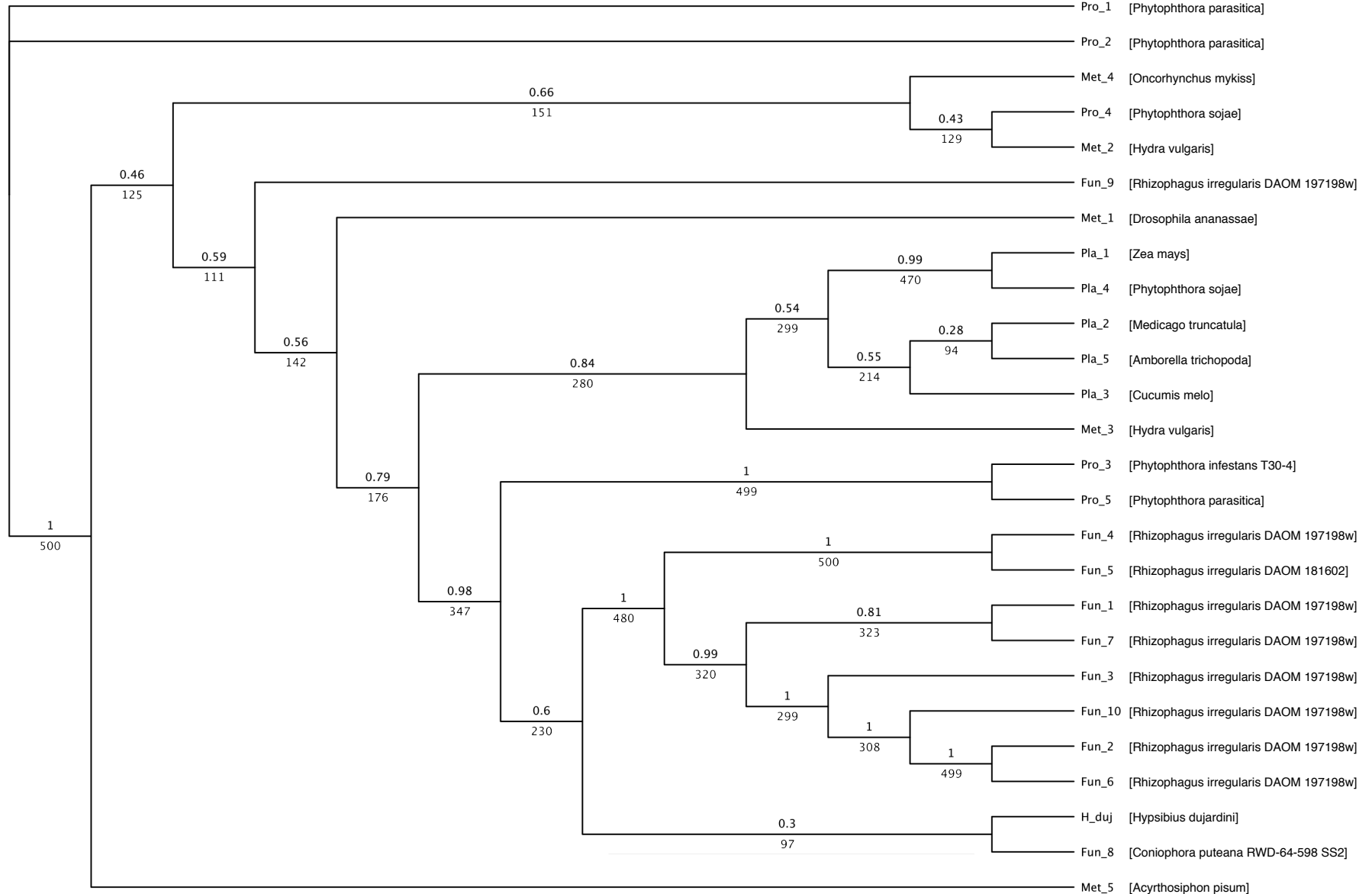

maker_scaffold81_size93674_augustus_gene_0.43

hypothetical protein PIIN_01307

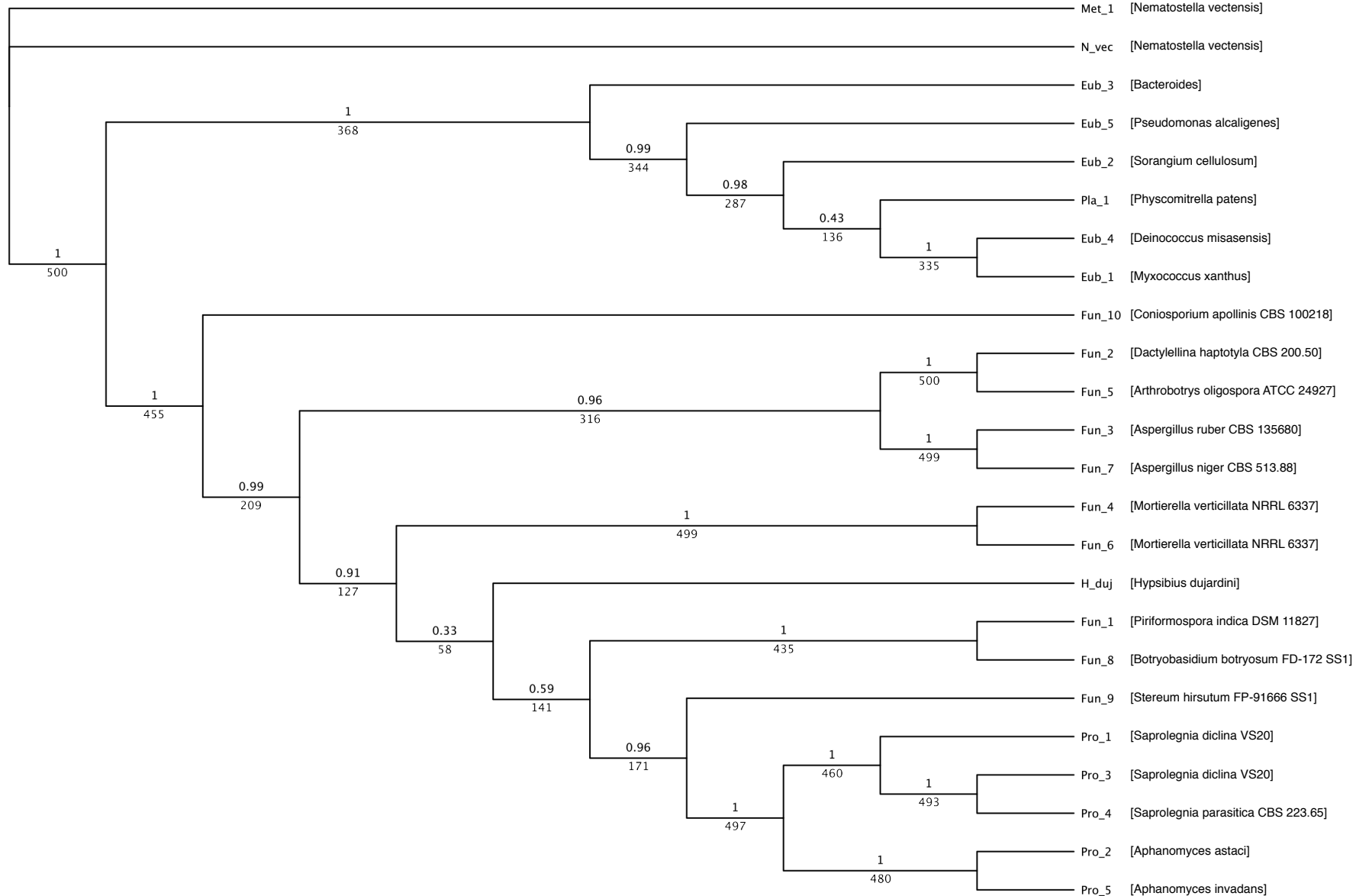

maker_scaffold80_size93979_augustus_gene_0.47

hypothetical protein AURDEDRAFT_172066

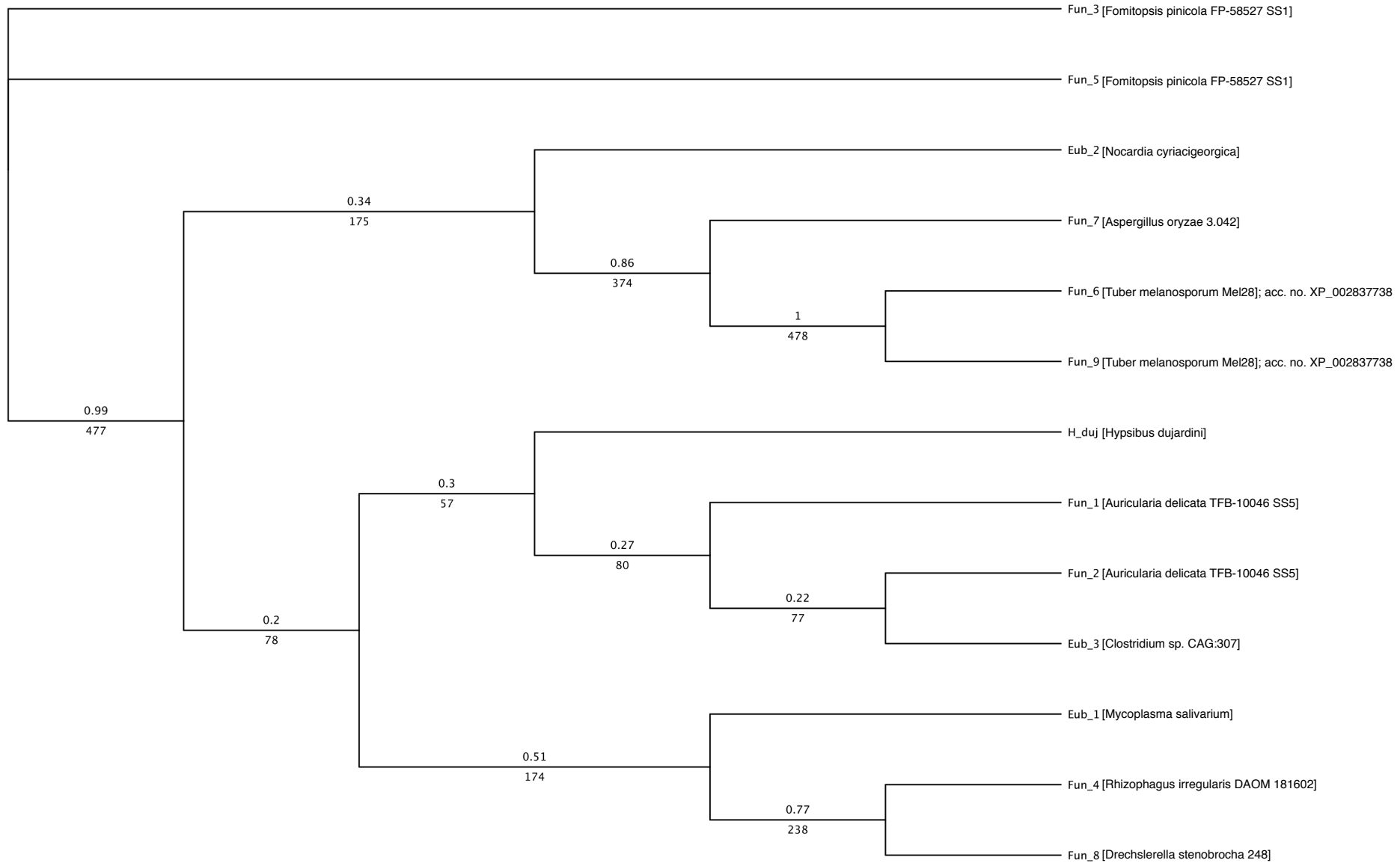

maker_scaffold74_size115697_snap_gene_0.80

alpha/beta hydrolase

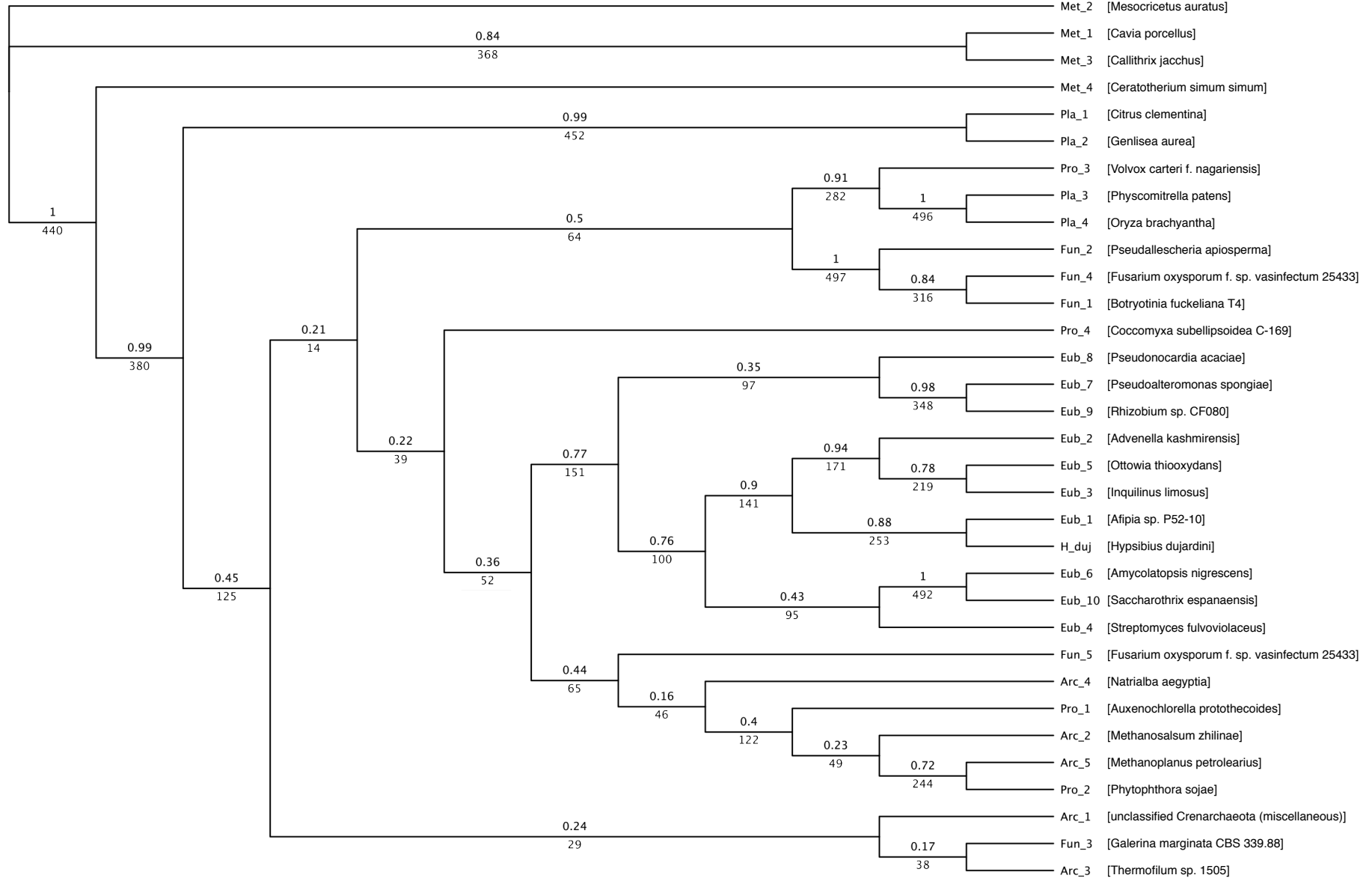

maker_scaffold48_augustus_gene_0.115

peptidase S9

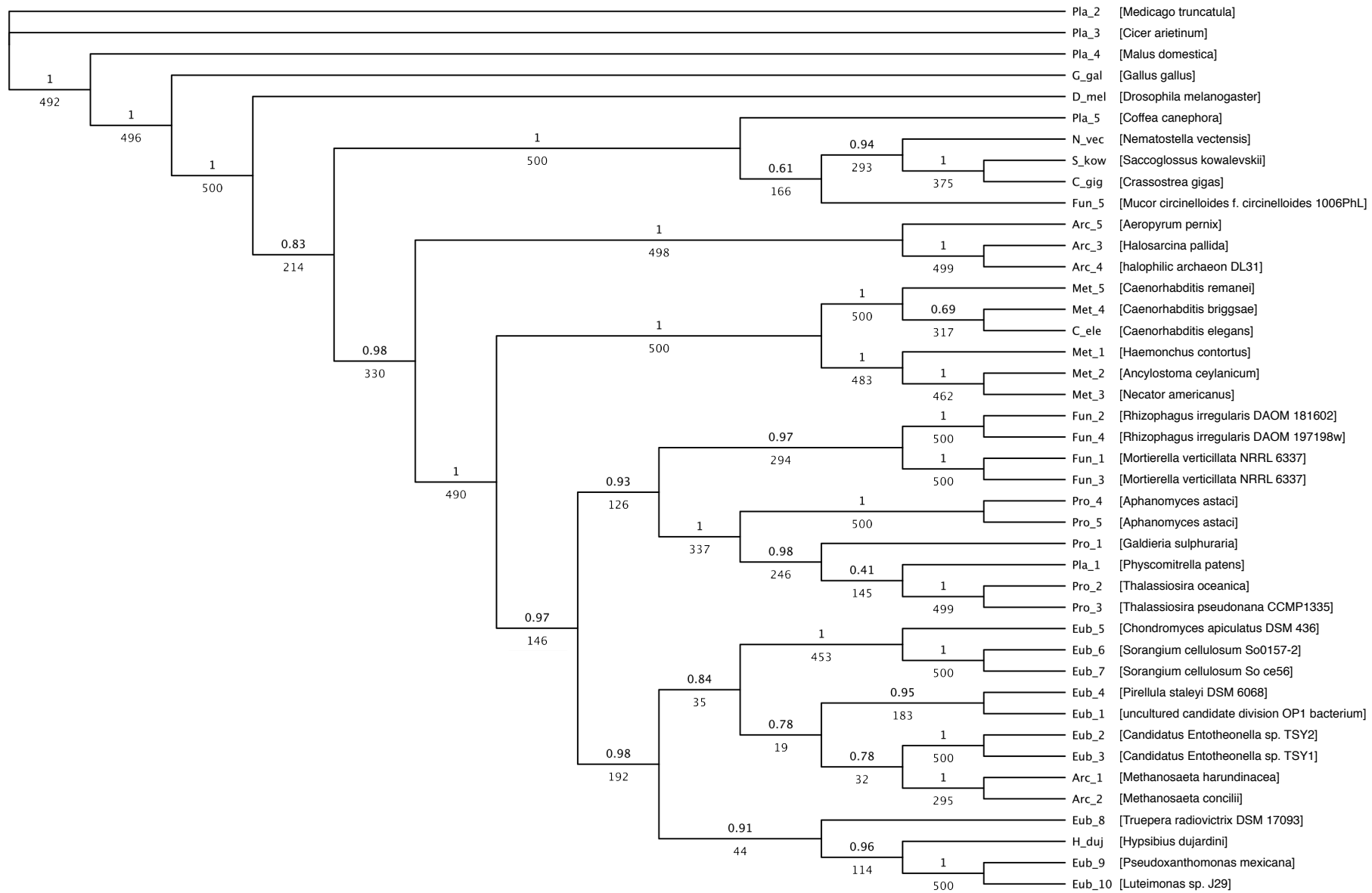

unnamed protein product

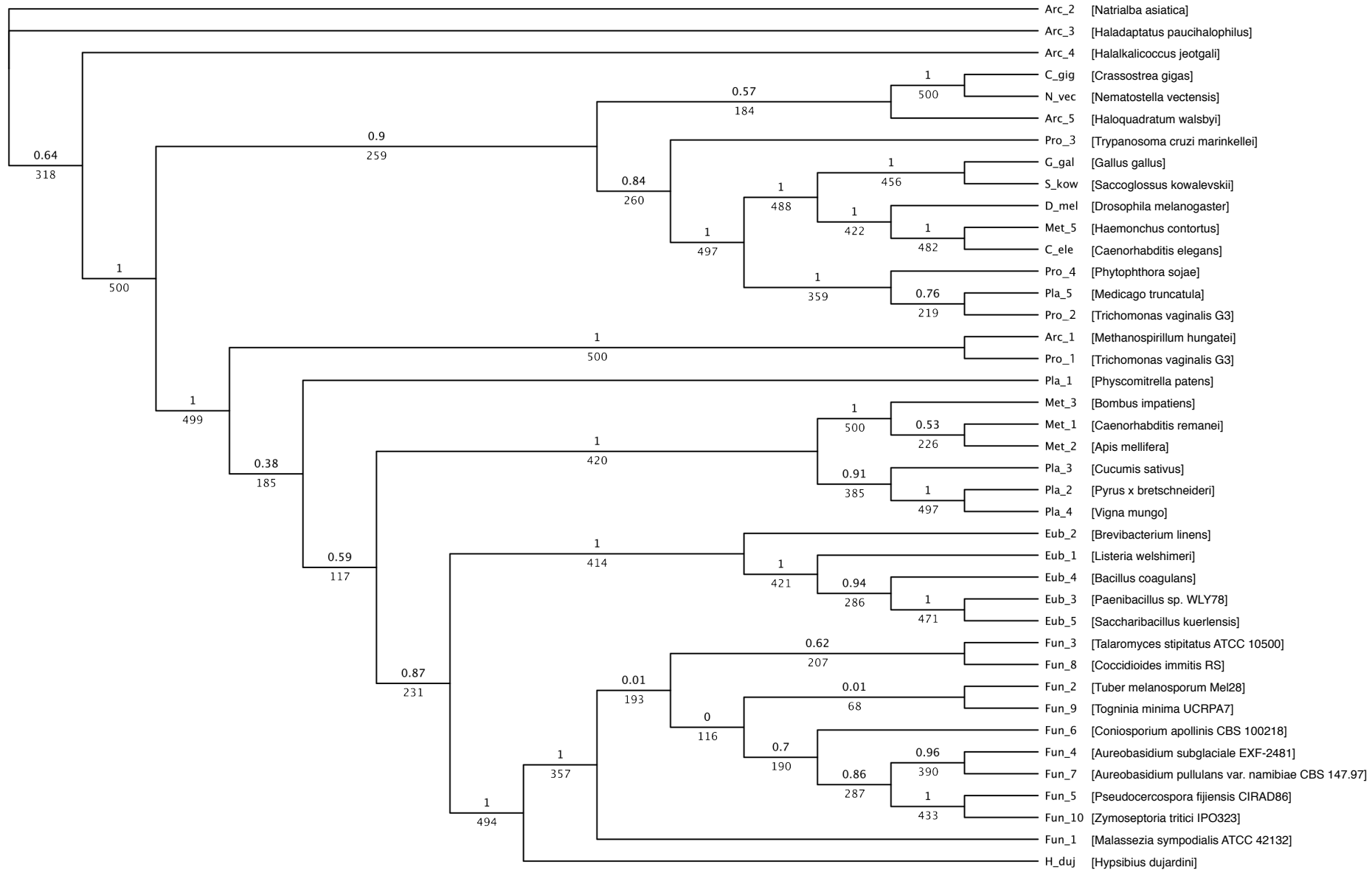

maker_scaffold10_size447749_snap_gene_2.50

thioredoxin

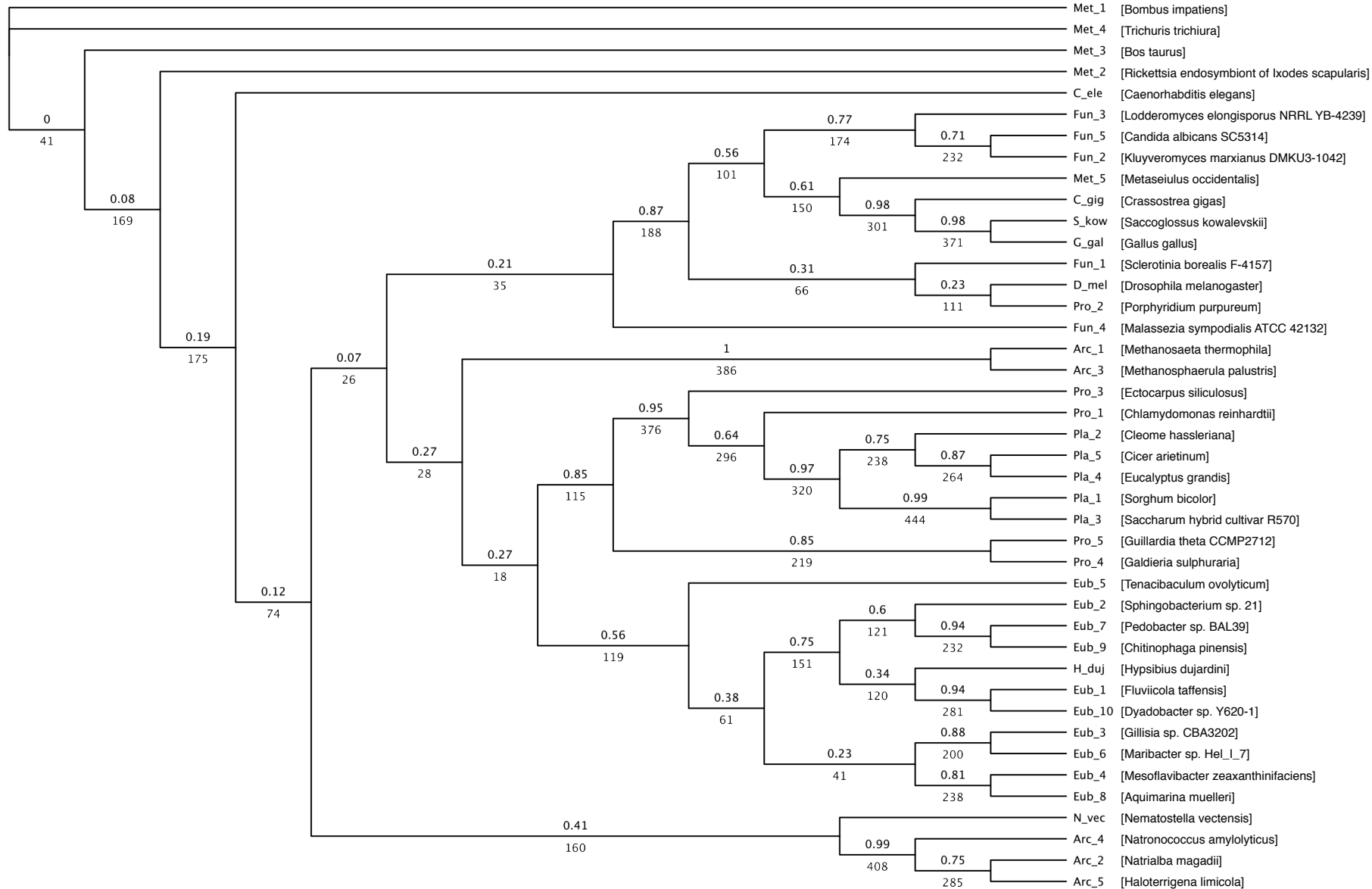

augustus_masked-scaffold16703_gene_0.3

enoyl-CoA hydratase

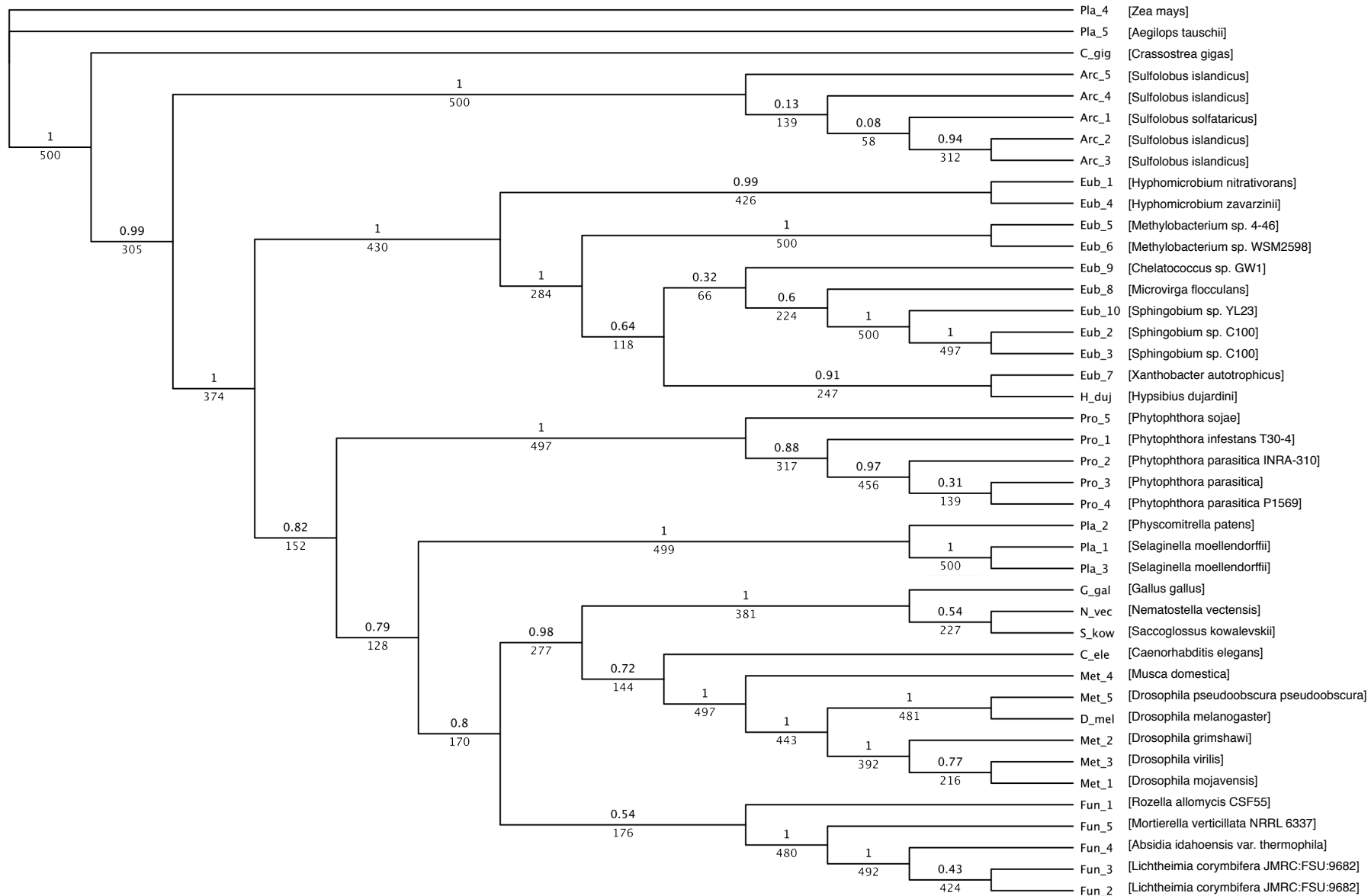

hypothetical protein

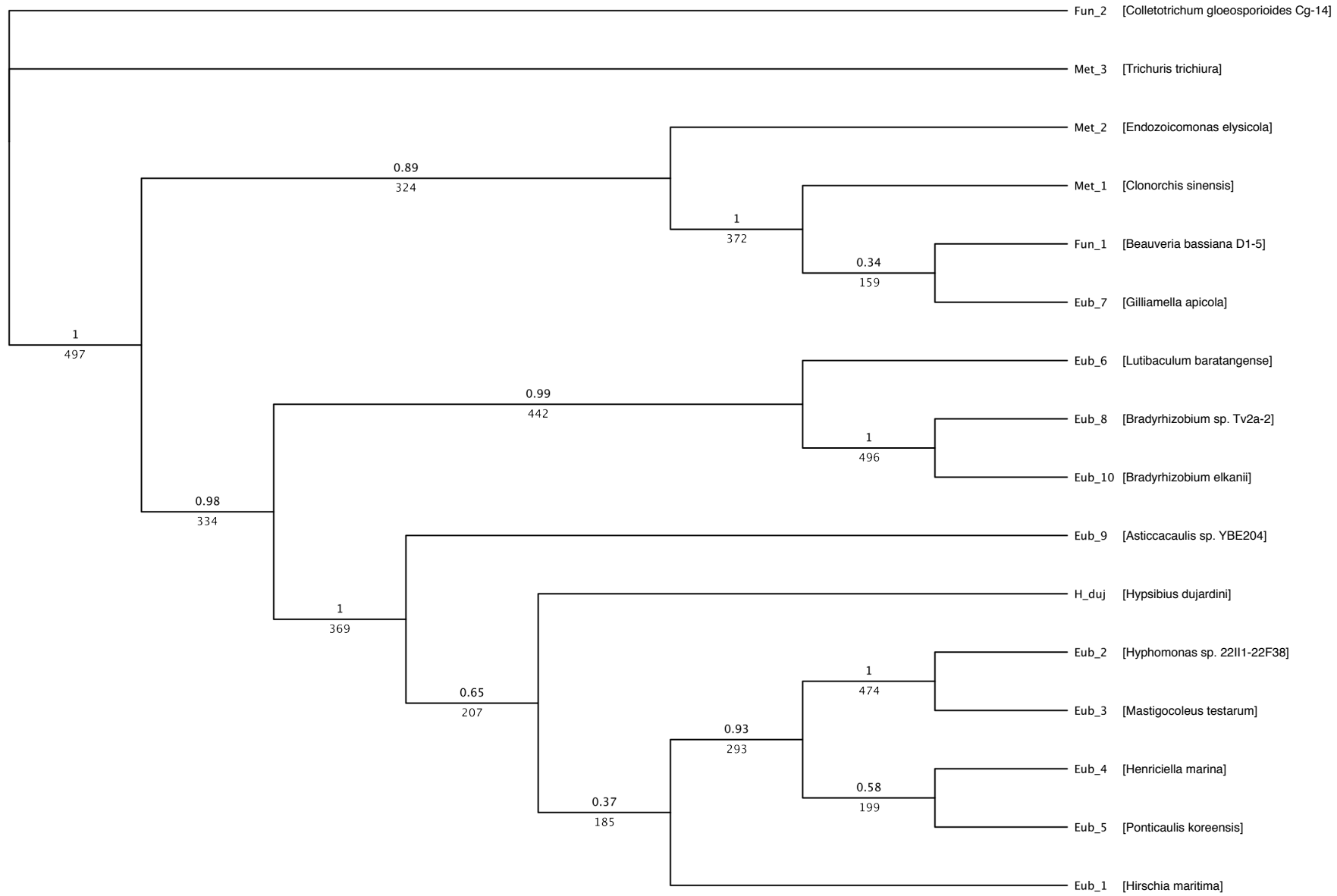

augustus_masked_scaffold16703_size5213_processed_gene_0.3

enoyl-CoA hydratase

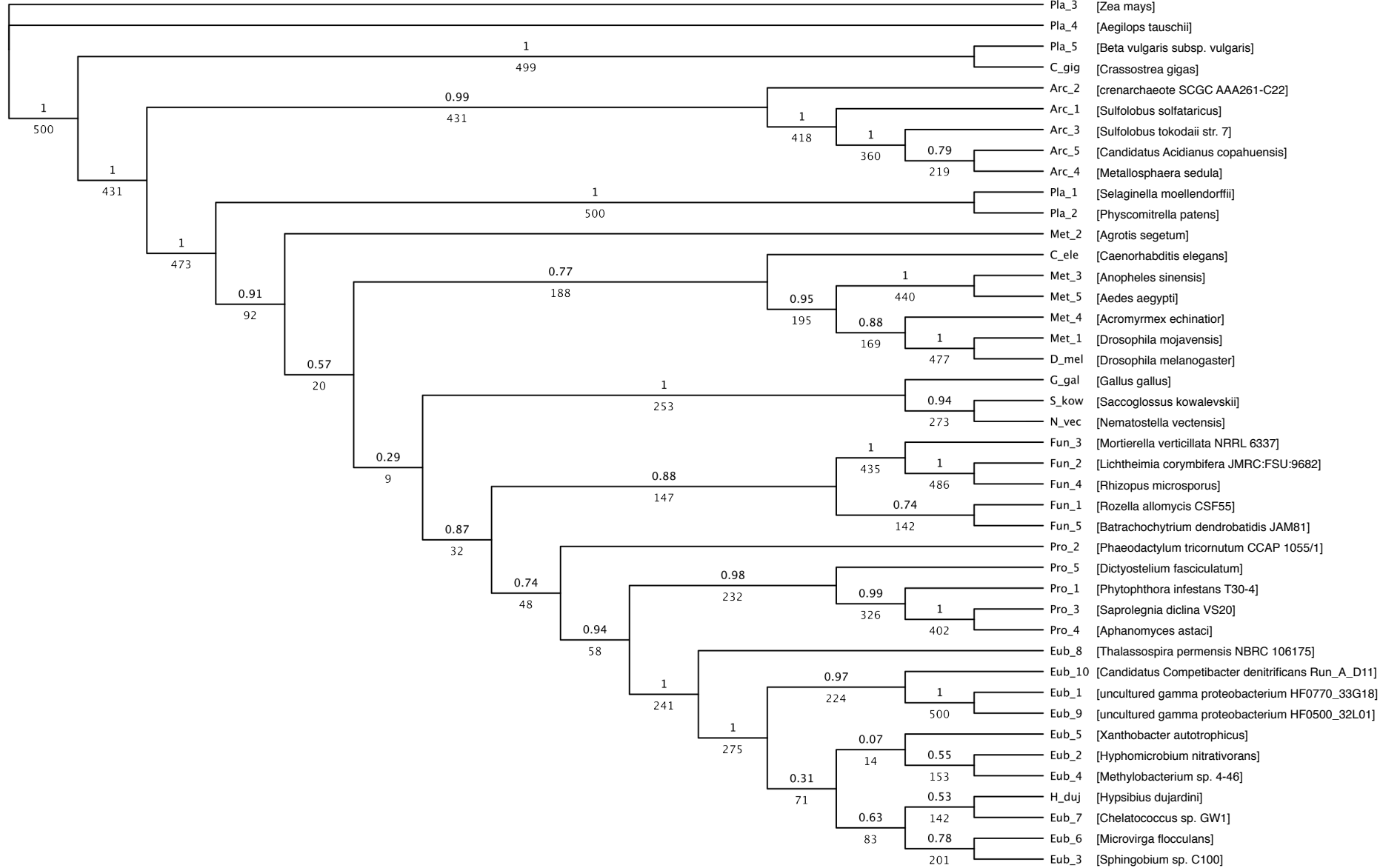

transcriptional regulator

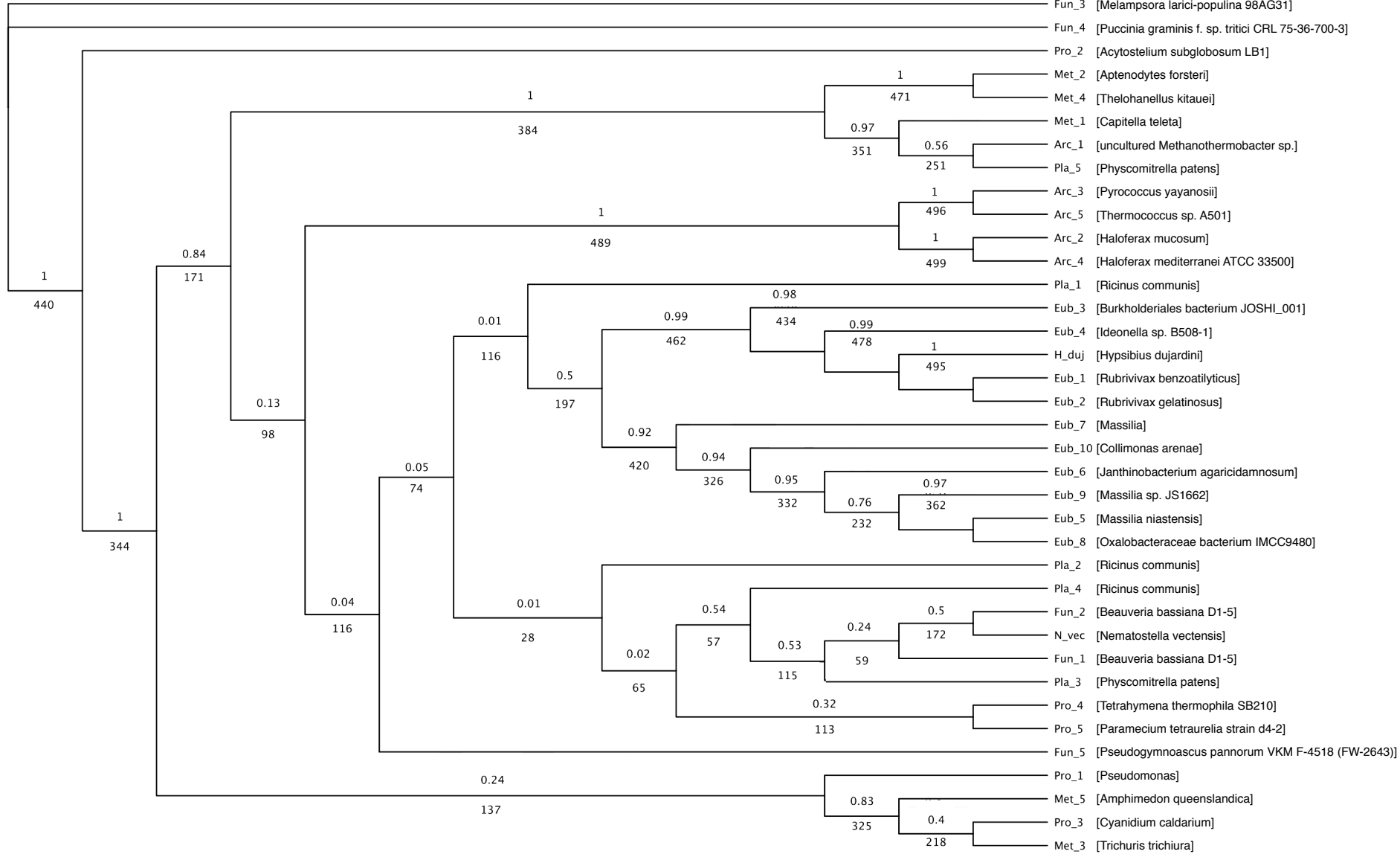

augustus_masked_scaffold12066_size7863_processed_gene_0.3

methionine aminopeptidase

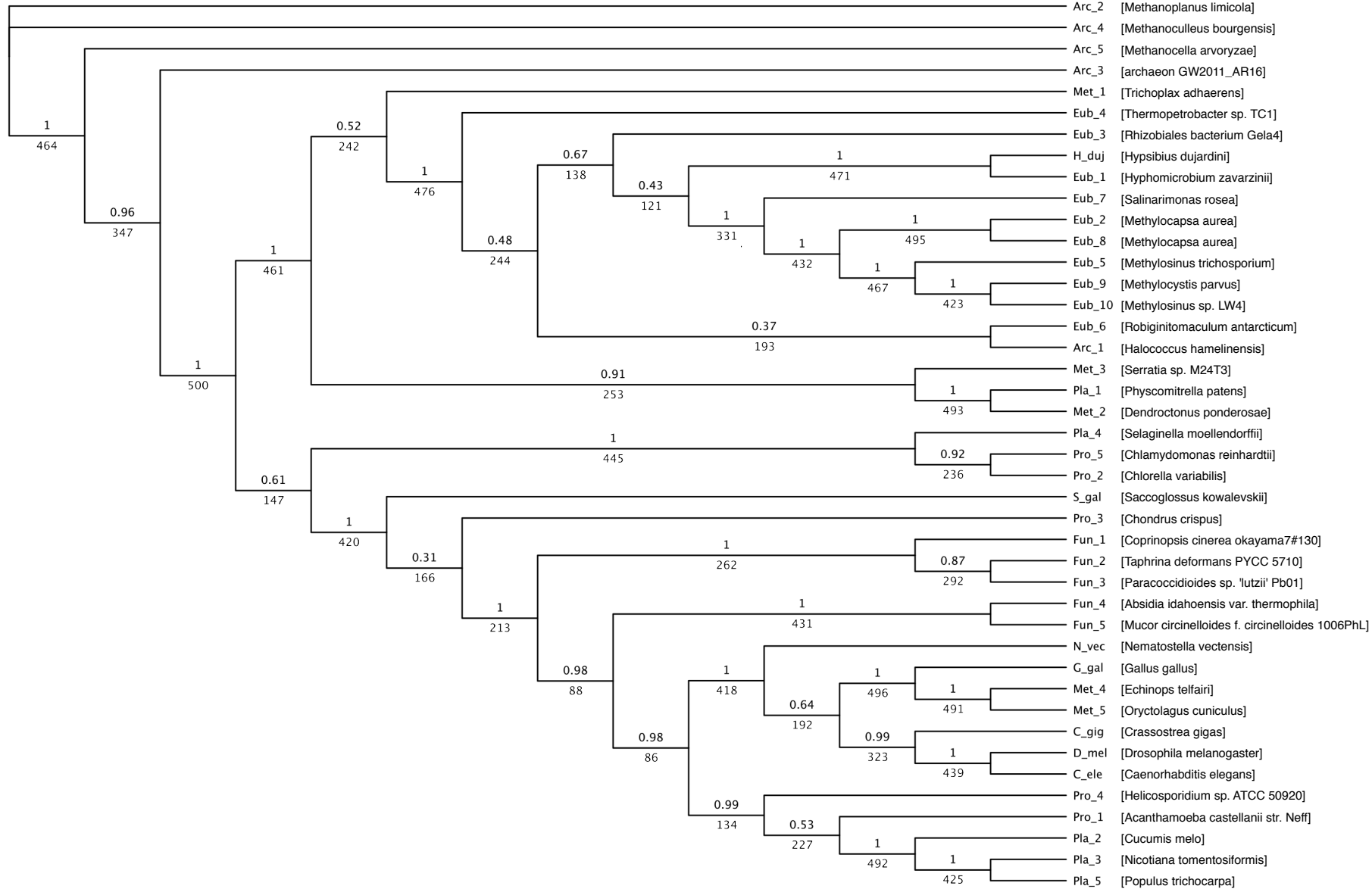

augustus_masked_scaffold10141_processed_gene_0.1

hypothetical protein EURHEDRAFT_467707

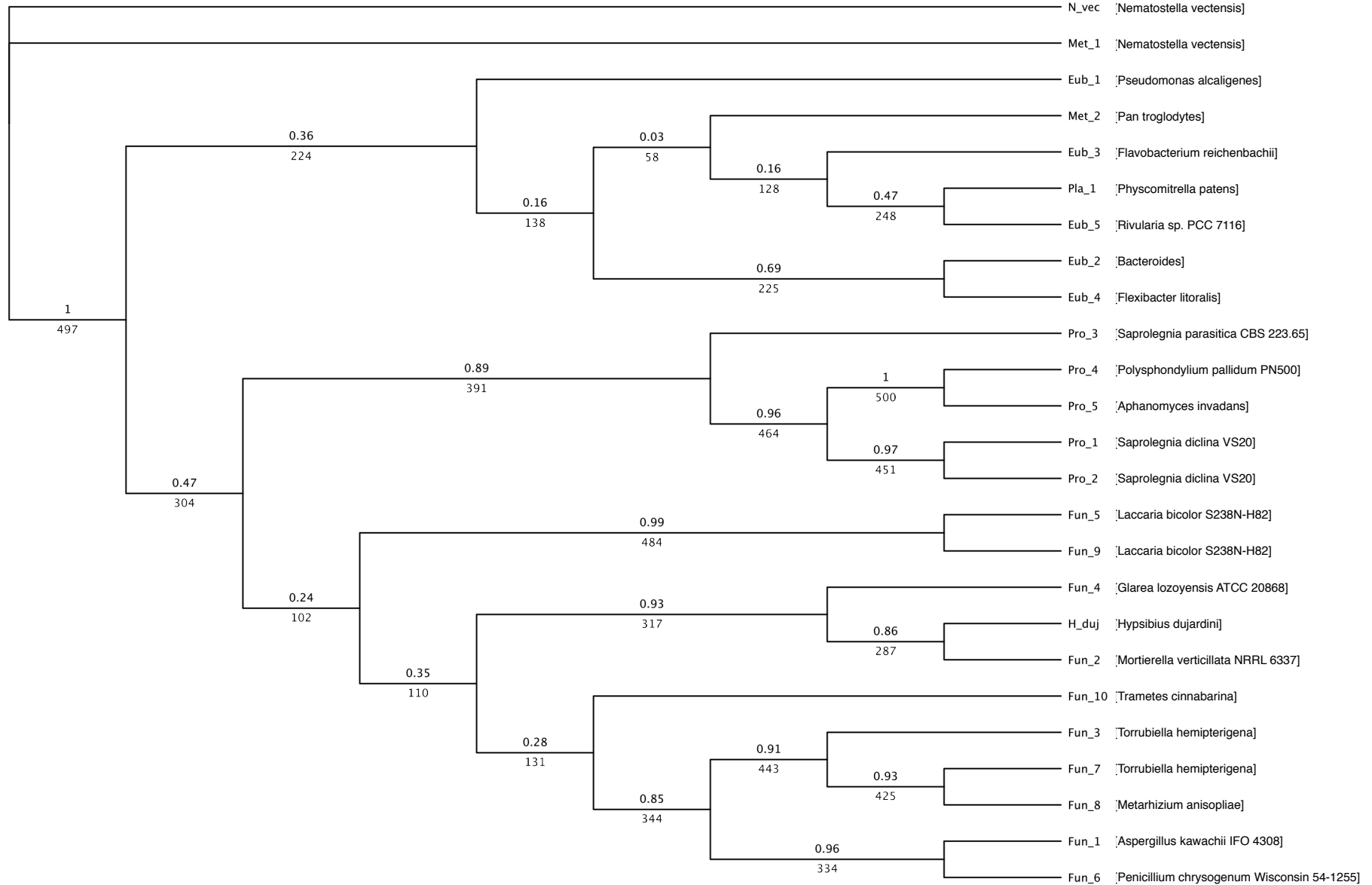

3-oxoacyl-ACP synthase

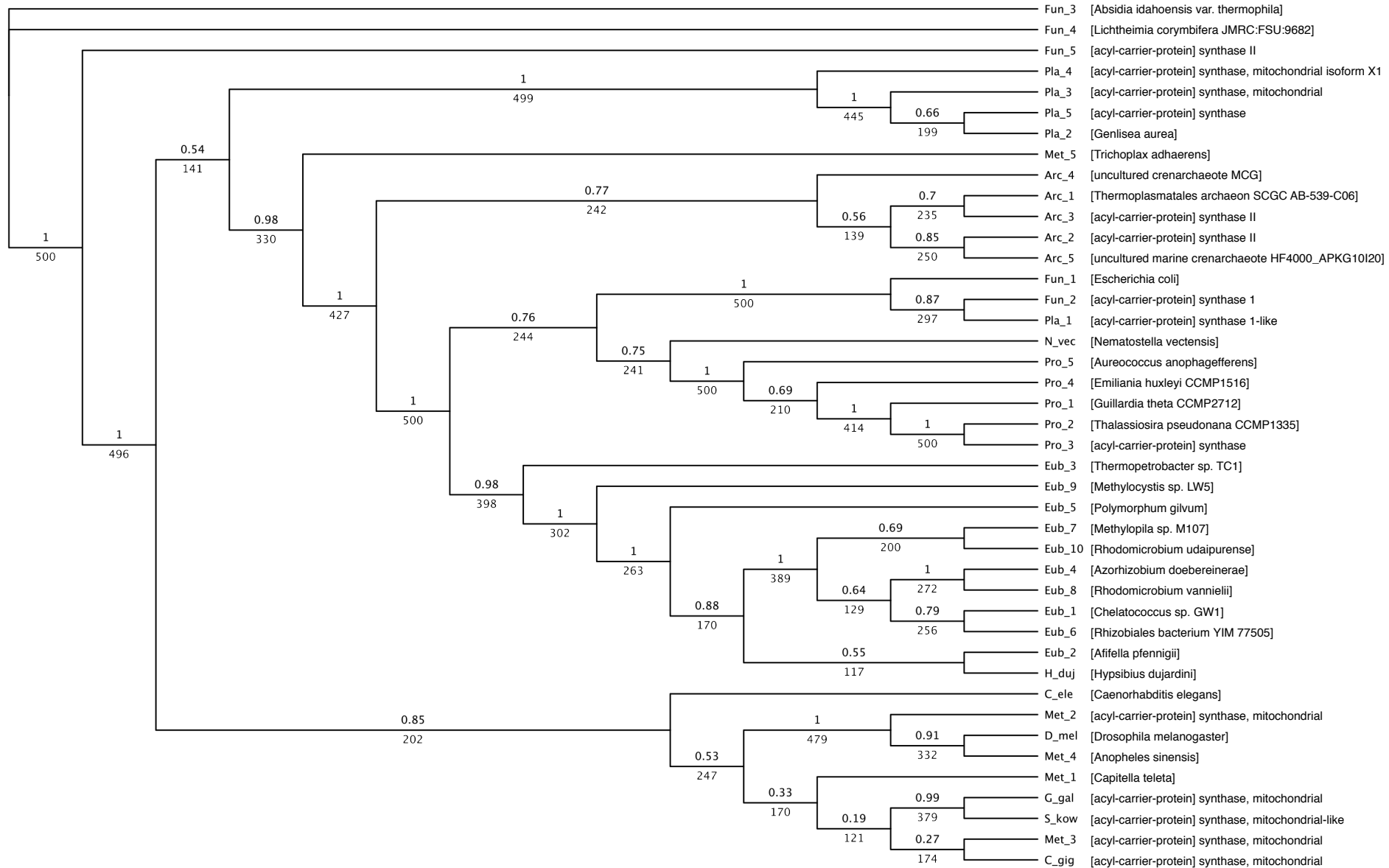

augustus_masked_scaffold9576_size9323_processed_gene_0.1

hypothetical protein BATDERAFT_89188

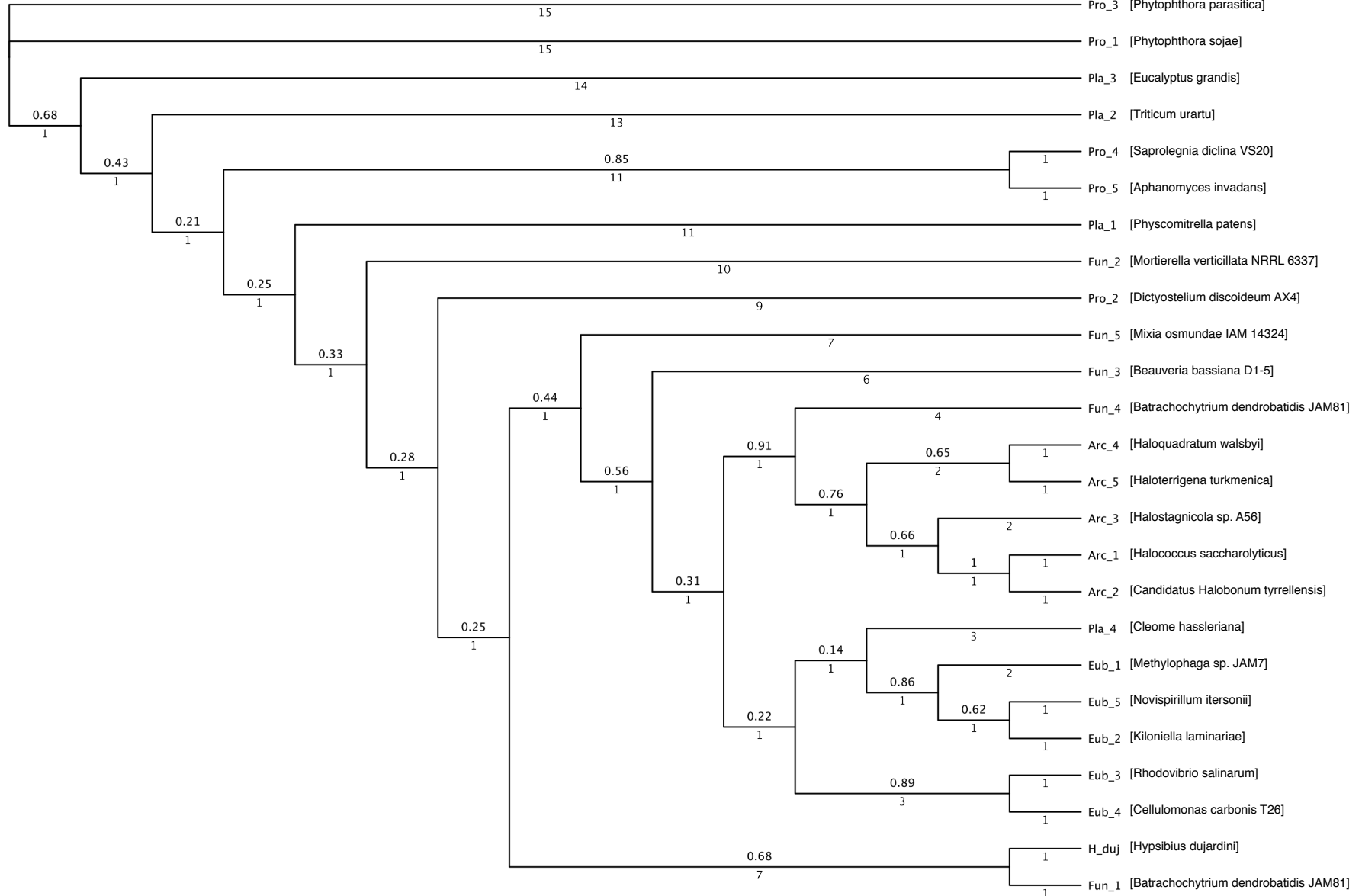

protein tyrosine phosphatase

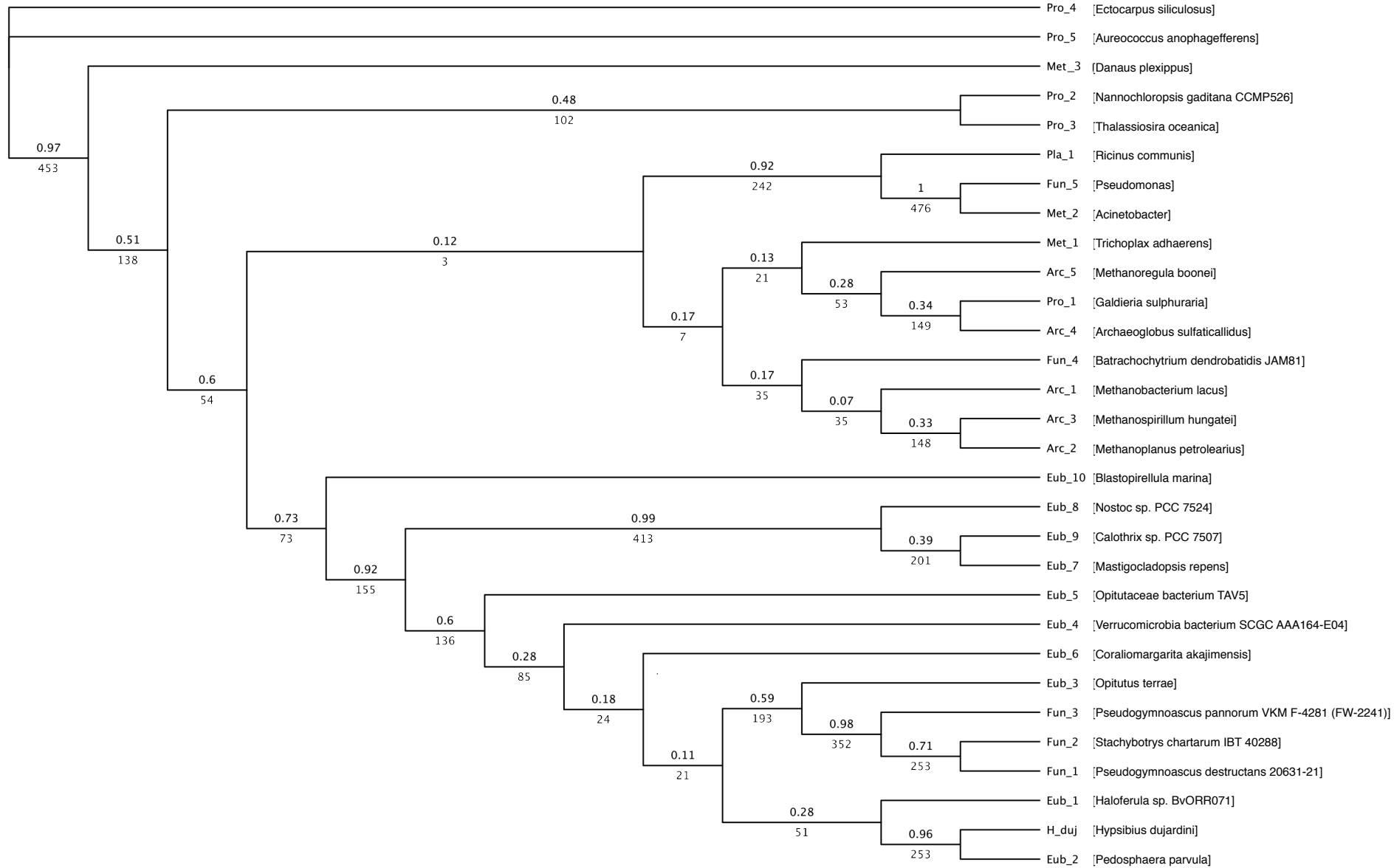

augustus_masked_scaffold1821_size45607_processed_gene_0.1

predicted protein

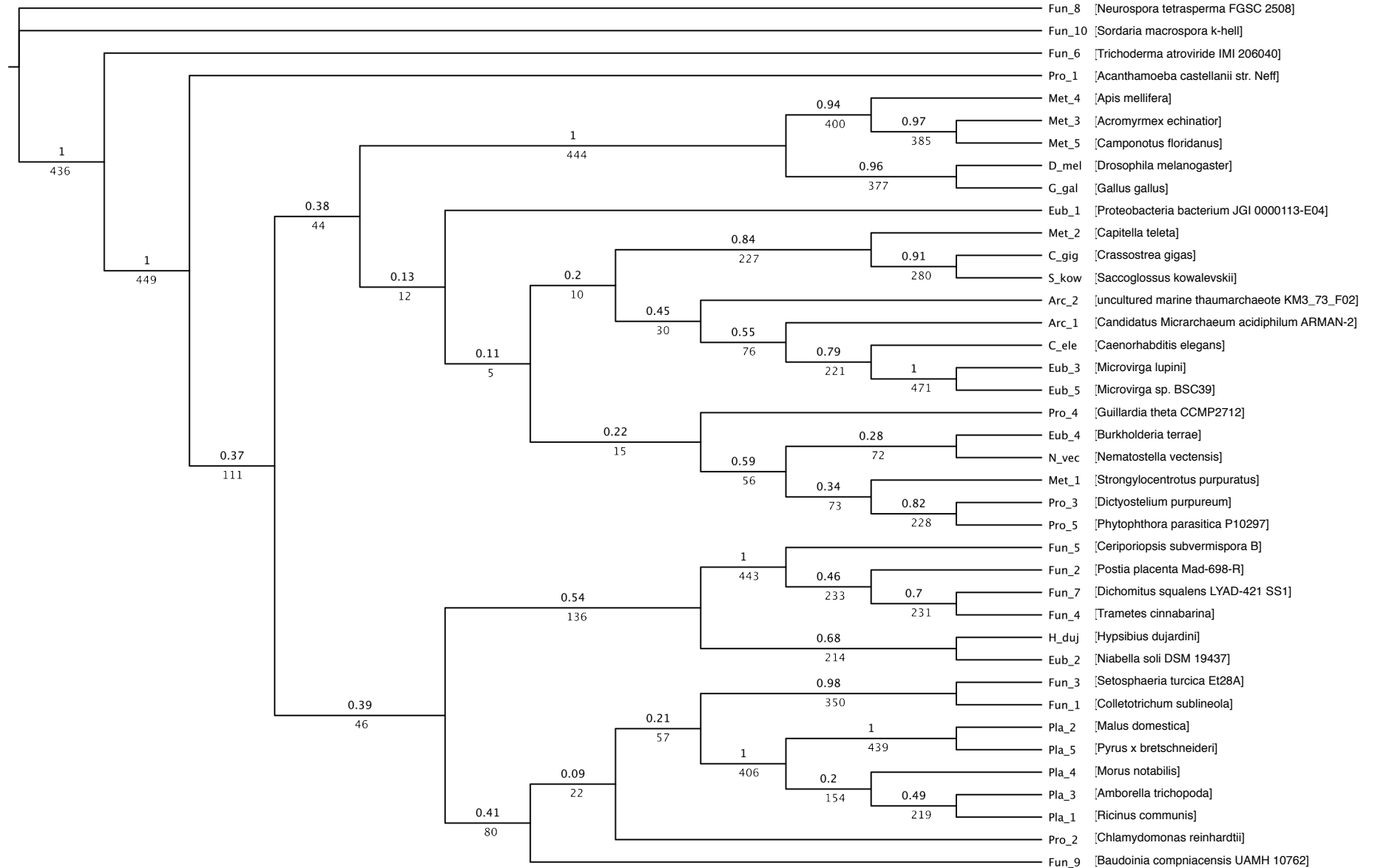

hypothetical protein mv_R860

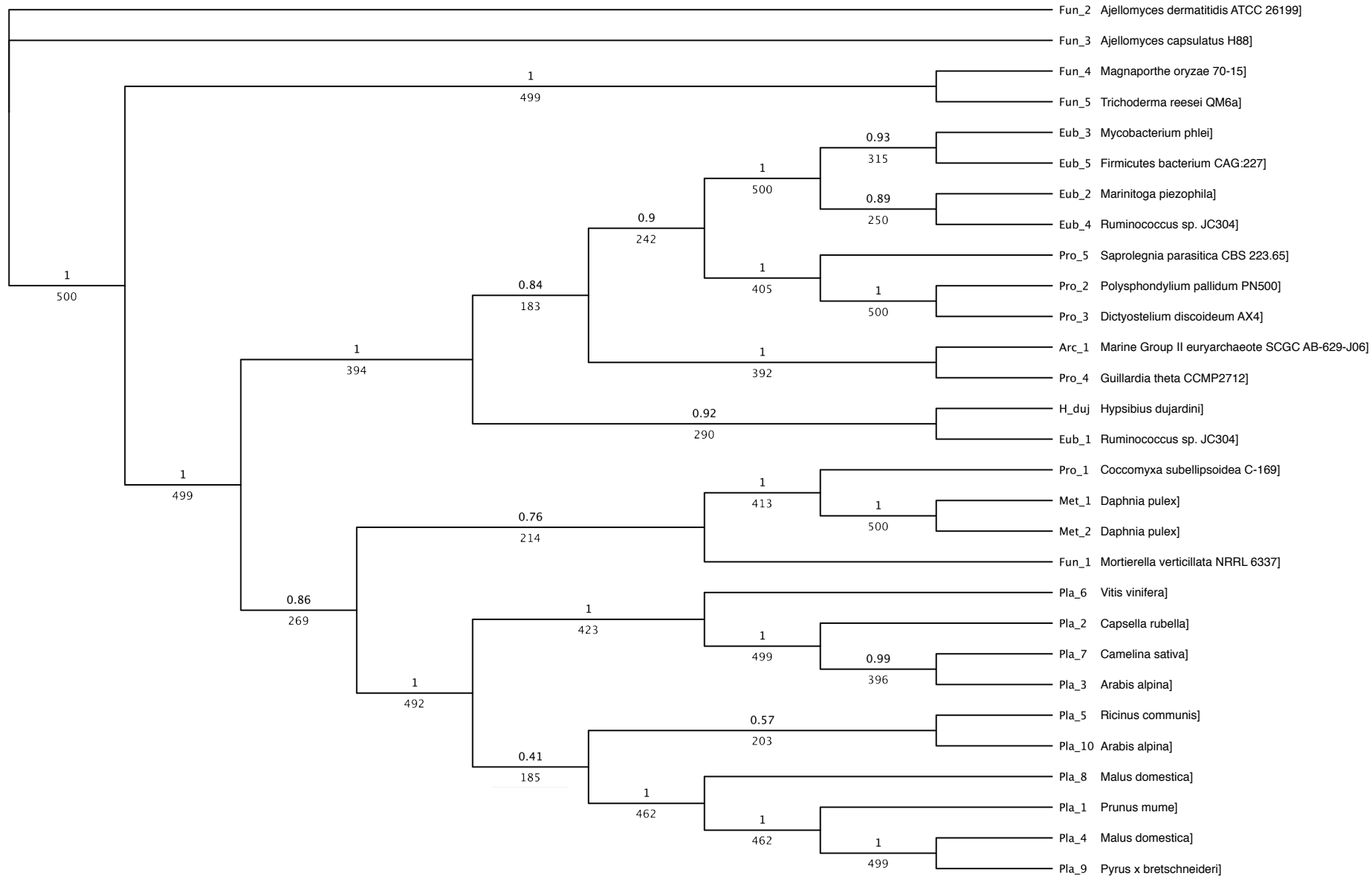

augustus_masked_scaffold1002_processed_gene_0.4

hypothetical protein BATDEDRAFT_8747

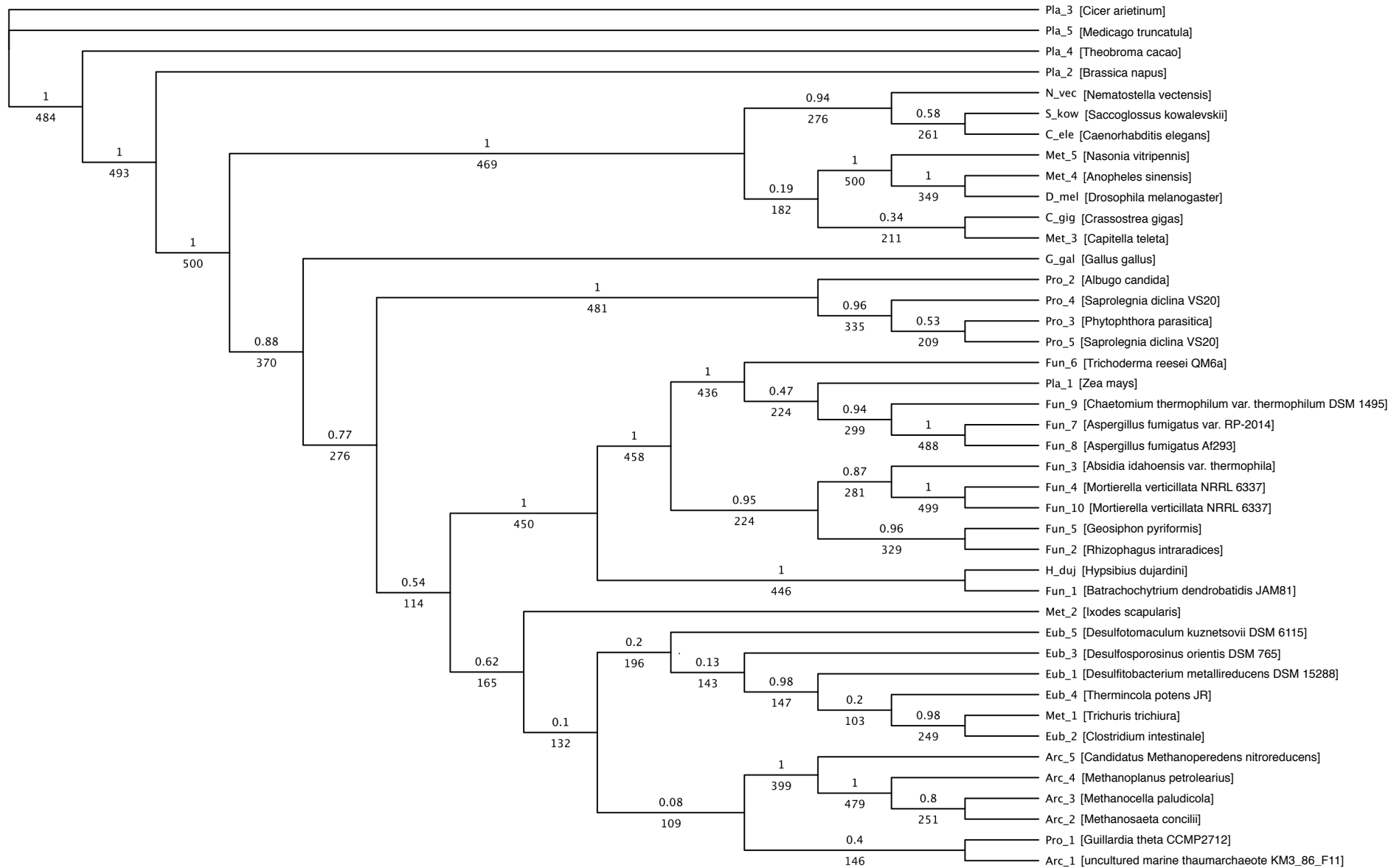

hypothetical protein mv_R860

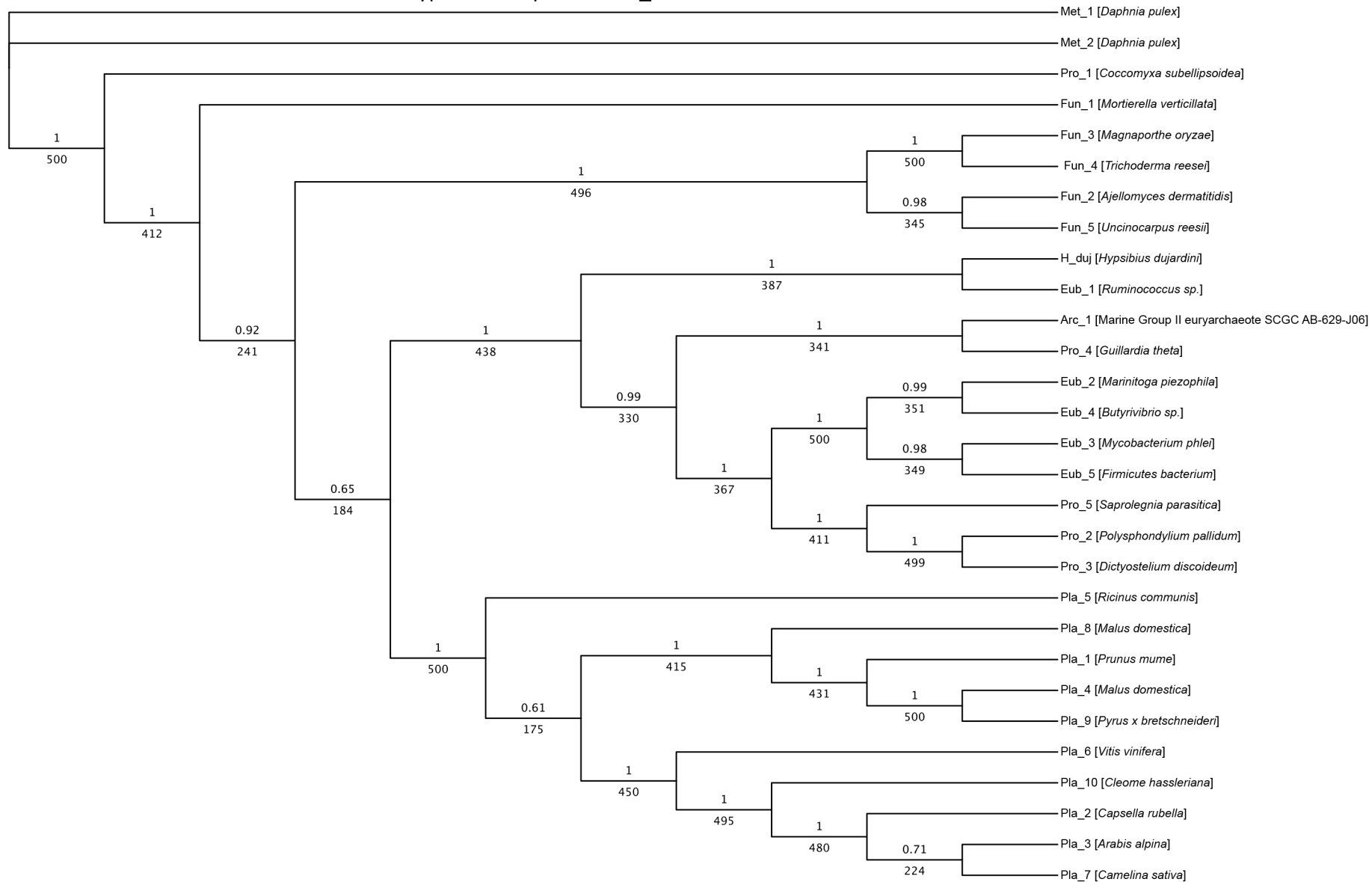

augustus_masked_scaffold634_size5575_processed_gene_0.11

Mannitol-1-phosphate/altronate dehydrogenase

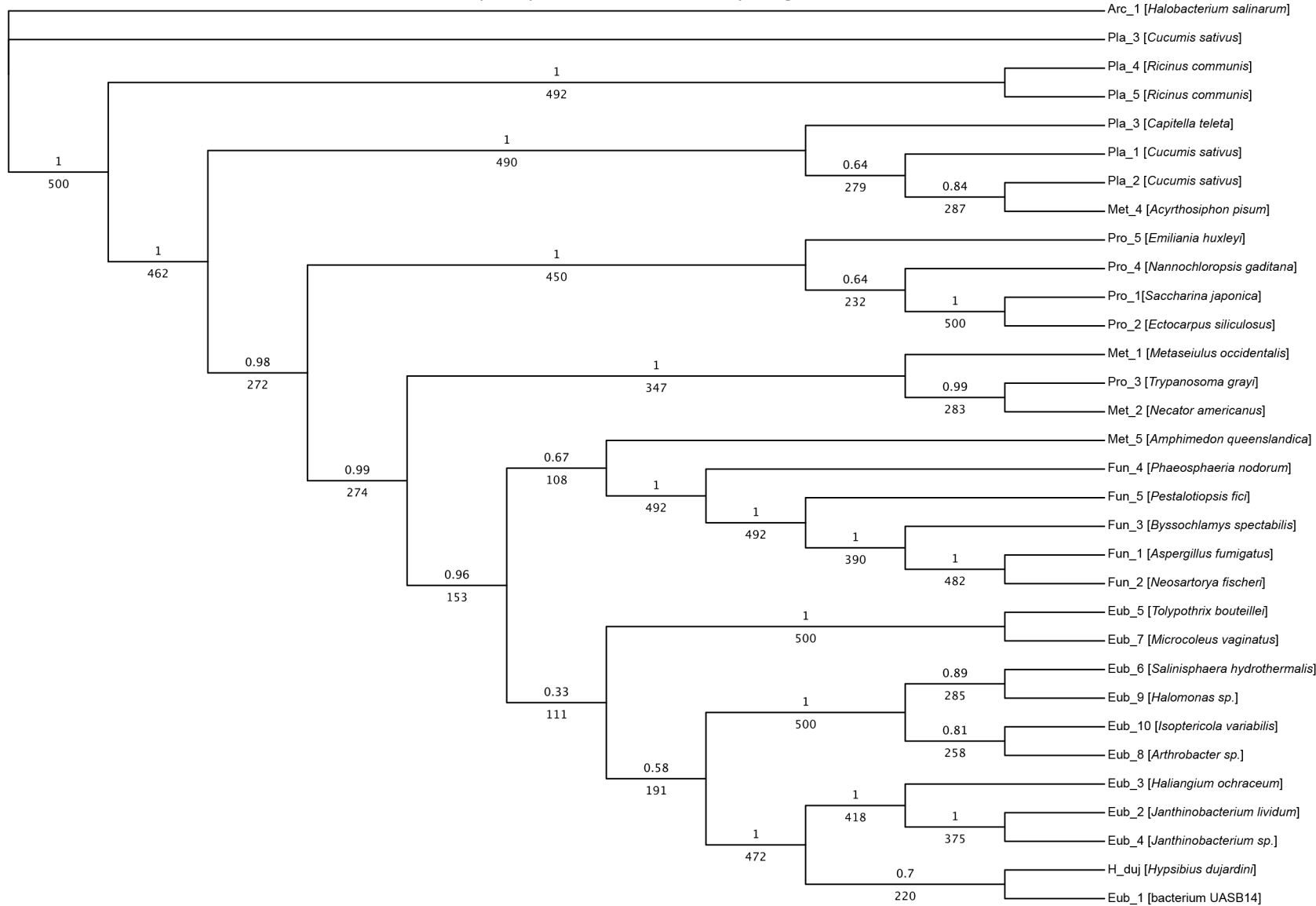

Gene trees – associated information

Tardgrade sequence	Accession	Taxon label in tree
snap_masked-scaffold2263_size22100-processed-gene-0.5	ETN85160.1	Met_1
	ELT98931.1	Met_2
	EGT36150.1	Met_3
	EYC08770.1	Met_4
	EYC08771.1	Met_5
	ADK93999.1	D_mel
	NP_001024899.1	C_ele
	EKC41578.1	C_gig
	XP_002734727.1	S_kow
	XP_007831537.1	Fun_1
	XP_658924.1	Fun_2
	KDN63488.1	Fun_3
	CBF87724.1	Fun_4
	KGQ13279.1	Fun_5
	EWM25928.1	Pro_1
	XP_001759460.1	Pla_1
	WP_012186262.1	Arch_1
	WP_015789392.1	Arch_2
	WP_006665629.1	Arch_3
	WP_006882641.1	Arch_4
	WP_006825181.1	Arch_5
	YP_005059695.1	Eub_1
	CDG83135.1	Eub_2
	WP_013579287.1	Eub_3
	WP_020719291.1	Eub_4
	YP_005058755.1	Eub_5
	WP_026389091.1	Eub_6
	YP_006421272.1	Eub_7
	WP_028556452.1	Eub_8
	WP_011682943.1	Eub_9
	WP_013568038.1	Eub_10
maker-scaffold187_size82271-snap-gene-0.46	XP_003343631.1	Fun_1
	XP_001744264.1	Pro_1
	YP_589610.1	Eub_1
	YP_002754580.1	Eub_2
	WP_020722206.1	Eub_3
	WP_013578580.1	Eub_4
	WP_011688571.1	Eub_5
	YP_005059566.1	Eub_6
	WP_020712994.1	Eub_7
	WP_006978381.1	Eub_8
	WP_012376870.1	Eub_9
	YP_001821414.1	Eub_10
snap_masked-scaffold16703_size5213-processed-gene-0.5	XP_003391632.1	Met_1

	XP_002405928.1	Met_2
	CDW59243.1	Met_3
	XP_002434443.1	Met_4
	XP_003469451.2	Met_5
	KGQ12990.1	Fun_1
	ELR03114.1	Fun_2
	KGQ13718.1	Fun_3
	XP_002617391.1	Fun_4
	ELQ40159.1	Fun_5
	YP_002048675.1	Pro_1
	EMH73293.1	Pro_2
	EKG06894.1	Pro_3
	ESS63401.1	Pro_4
	XP_004153787.1	Pla_1
	KFK36644.1	Pla_2
	XP_007207021.1	Pla_3
	WP_018034704.1	Arc_1
	WP_008365813.1	Arc_2
	YP_007912694.1	Eub_1
	WP_013945660.1	Eub_2
	YP_003754151.1	Eub_3
	WP_026867960.1	Eub_4
	WP_023785623.1	Eub_5
	KAI95030.1	Eub_6
	YP_004010392.1	Eub_7
	WP_028162525.1	Eub_8
	WP_024584553.1	Eub_9
	WP_027279200.1	Eub_10
maker-scaffold16610_size5253-snap-gene-0.7	XP_009009293.1	Met_1
	CBY12957.1	Met_2
	KFM58494.1	Met_3
	XP_004227501.1	Met_4
	XP_009057605.1	Met_5
	NP_001247377.1	D_mel
	NP_001021293.2	C_ele
	EKC31672.1	C_gig
	XP_006819680.1	S_kow
	NP_001025511.1	G_gal
	CCH23110.1	N_vec
	CCH44043.1	Fun_1
	XP_007757298.1	Fun_2
	CEF77135.1	Fun_3
	XP_388900.1	Fun_4
	EYB29890.1	Fun_5
	EPY28623.1	Pro_1

	XP_009845357.1	Pro_2
	XP_008893292.1	Pro_3
	ETO73763.1	Pro_4
	XP_008893294.1	Pro_5
	XP_002534659.1	Pla_1
	XP_004150911.1	Pla_2
	XP_009351296.1	Pla_3
	AEK86563.1	Pla_4
	XP_004290707.1	Pla_5
	WP_006882632.1	Arc_1
	KDE57447.1	Arc_2
	WP_008095220.1	Arc_3
	WP_004974838.1	Arc_4
	WP_004969548.1	Arc_5
	WP_016715768.1	Eub_1
	YP_606197.1	Eub_2
	WP_025754029.1	Eub_3
	AIN61587.1	Eub_4
	WP_028689034.1	Eub_5
	WP_009685235.1	Eub_6
	AHD12543.1	Eub_7
	AIL59673.1	Eub_8
	WP_024086160.1	Eub_9
	WP_016484610.1	Eub_10
maker-scaffold1034_size31628-snap-gene-0.53	XP_003390807.1	Met_1
	XP_003390808.1	Met_2
	CDW55151.1	Met_3
	XP_003390336.1	Met_4
	ETN83556.1	Met_5
	NP_730301.3	D_mel
	NP_493041.1	C_ele
	EKC17257.1	C_gig
	XP_006815639.1	S_kow
	XP_422330.3	G_gal
	XP_001618124.1	N_vec
	KGQ11105.1	Fun_1
	KGQ13405.1	Fun_2
	KGQ13406.1	Fun_3
	KGQ02342.1	Fun_4
	KGQ13942.1	Fun_5
	YP_009051152.1	Pro_1
	NP_848950.1	Pro_2
	YP_009020823.1	Pro_3
	NP_045139.1	Pro_4
	YP_005089900.1	Pro_5

	EEC68421.1	Pla_1
	XP_004151223.1	Pla_2
	EEC68416.1	Pla_3
	XP_004154075.1	Pla_4
	XP_002538475.1	Pla_5
	WP_021044468.1	Arc_1
	WP_008441535.1	Arc_2
	WP_017344028.1	Arc_3
	WP_007345288.1	Arc_4
	WP_008367388.1	Arc_5
	YP_004987465.1	Eub_1
	CDN66896.1	Eub_2
	YP_003524199.1	Eub_3
	WP_026074386.1	Eub_4
	WP_027010394.1	Eub_5
	WP_018273463.1	Eub_6
	WP_018111969.1	Eub_7
	WP_028333378.1	Eub_8
	YP_001642290.1	Eub_9
	WP_018273463.1	Eub_10
maker-scaffold115_size79125-snap-gene-0.80	CDW60463.1	Met_1
	CDW59420.1	Met_2
	XP_003389916.1	Met_3
	XP_003088060.1	Met_4
	AAX33608.1	D_mel
	NP_509205.2	C_ele
	EKC17175.1	C_gig
	XP_006814548.1	S_kow
	XP_418636.4	G_gal
	XP_001618124.1	N_vec
	KGQ13962.1	Fun_1
	KGQ11115.1	Fun_2
	KGQ13055.1	Fun_3
	KGQ06063.1	Fun_4
	KGQ06104.1	Fun_5
	WP_013875775.1	Pro_1
	WP_008006286.1	Pro_2
	WP_015790313.1	Pro_3
	WP_008526693.1	Pro_4
	WP_009377651.1	Pro_5
	EEC78702.1	Pla_1
	XP_004151395.1	Pla_2
	XP_004153905.1	Pla_3
	XP_002534826.1	Pla_4
	EAY93131.1	Pla_5

	WP_013875775.1	Arc_1
	WP_008006286.1	Arc_2
	WP_015790313.1	Arc_3
	WP_008526693.1	Arc_4
	WP_004977793.1	Arc_5
	WP_013875711.1	Arc_6
	WP_007694542.1	Arc_7
	WP_013875807.1	Arc_8
	WP_008526858.1	Arc_9
	WP_006883492.1	Arc_10
	AIS52208.1	Eub_1
	WP_016742738.1	Eub_2
	WP_026042936.1	Eub_3
	YP_002769818.1	Eub_4
	WP_031416280.1	Eub_5
maker-scaffold117_size78986-augustus-gene-0.84	XP_003390883.1	Met_1
	XP_003494811.1	Met_2
	ELU02337.1	Met_3
	XP_003389625.1	Met_4
	ELU04438.1	Met_5
	KGQ13756.1	Fun_1
	KGQ11302.1	Fun_2
	XP_006683192.1	Fun_3
	KGQ13060.1	Fun_4
	KDN34651.1	Fun_5
	YP_001019170.1	Pro_1
	NP_038441.1	Pro_2
	YP_636569.1	Pro_3
	YP_009105912.1	Pro_4
	YP_009104931.1	Pro_5
	YP_007026185.1	Pla_1
	NP_039346.1	Pla_2
	AAG41902.1	Pla_3
	NP_777462.1	Pla_4
	ABX00569.1	Pla_5
	WP_011843494.1	Arc_1
	WP_014404761.1	Arc_2
	WP_014867666.1	Arc_3
	WP_012035702.1	Arc_4
	WP_004037770.1	Arc_5
	YP_003321306.1	Eub_1
	AHY48349.1	Eub_2
	WP_029476644.1	Eub_3
	WP_029483079.1	Eub_4
	EYB69185.1	Eub_5

	YP_003323049.1	Eub_6
	WP_019008837.1	Eub_7
	WP_019902200.1	Eub_8
	YP_645380.1	Eub_9
	ETX06459.1	Eub_10
maker-scaffold4690_size14997-snap-gene-0.16	EZA47087.1	Met_1
	XP_002161039.2	Met_2
	EGI64323.1	Met_3
	XP_009026759.1	Met_4
	XP_003489091.1	Met_5
	NP_476841.1	D_mel
	NP_001021584.1	C_ele
	EKC26070.1	C_gig
	XP_002731016.1	S_kow
	NP_001171688.1	G_gal
	XP_001625612.1	N_vec
	CDS10475.1	Fun_1
	CEG65538.1	Fun_2
	CDH54952.1	Fun_3
	EPB93105.1	Fun_4
	ESA16581.1	Fun_5
	XP_728665.1	Pro_1
	XP_001020979.1	Pro_2
	EAS00734.2	Pro_3
	XP_642518.1	Pro_4
	AAC47024.1	Pro_5
	XP_004516362.1	Pla_1
	XP_010036324.1	Pla_2
	XP_002975564.1	Pla_3
	XP_002973537.1	Pla_4
	EPS69017.1	Pla_5
	WP_015052778.1	Arc_1
	BAM69424.1	Arc_2
	WP_023845946.1	Arc_3
	WP_013295480.1	Arc_4
	WP_012899880.1	Arc_5
	WP_012036017.1	Arc_6
	3FZI_A	Arc_7
	WP_015325096.1	Arc_8
	KGK99262.1	Arc_9
	WP_013824740.1	Arc_10
	YP_005845493.1	Eub_1
	GAK55472.1	Eub_2
	KDR96246.1	Eub_3
	WP_029716760.1	Eub_4

	YP_007940929.1	Eub_5
maker-scaffold48_size118896-augustus-gene-0.115	CDJ94783.1	Met_1
	EYC21918.1	Met_2
	ETN75960.1	Met_3
	XP_002643051.1	Met_4
	XP_003104942.1	Met_5
	NP_996292.2	D_mel
	NP_741240.1	C_ele
	EKC34559.1	C_gig
	XP_002736640.1	S_kow
	NP_001025756.1	G_gal
	XP_001636103.1	N_vec
	KFH73944.1	Fun_1
	ERZ94672.1	Fun_2
	KFH73994.1	Fun_3
	EXX59623.1	Fun_4
	EPB85777.1	Fun_5
	XP_005708640.1	Pro_1
	EJK73213.1	Pro_2
	XP_002296439.1	Pro_3
	XP_009837732.1	Pro_4
	XP_009837727.1	Pro_5
	XP_001753431.1	Pla_1
	XP_003637575.1	Pla_2
	XP_004498000.1	Pla_3
	XP_008341037.1	Pla_4
	CDP07619.1	Pla_5
	WP_014587630.1	Arc_1
	WP_013717995.1	Arc_2
	WP_008389279.1	Arc_3
	WP_014052983.1	Arc_4
	WP_010867008.1	Arc_5
	BAL59919.1	Eub_1
	ETW96694.1	Eub_2
	ETW95828.1	Eub_3
	YP_003373270.1	Eub_4
	EYF01151.1	Eub_5
	YP_008153959.1	Eub_6
	YP_001617056.1	Eub_7
	YP_003704627.1	Eub_8
	BAO18428.1	Eub_9
	WP_027070836.1	Eub_10
snap_masked-scaffold5085_size14234-processed-gene-0.8	XP_003694894.1	Met_1
	XP_003494199.1	Met_2
	CDW59144.1	Met_3

	EYB84565.1	Met_4
	EYB84563.1	Met_5
	AAL90373.1	D_mel
	NP_001022623.1	C_ele
	EKC18878.1	C_gig
	XP_002741112.1	S_kow
	NP_001025820.1	G_gal
	XP_001619345.1	N_vec
	ESX01276.1	Fun_1
	EIF46696.1	Fun_2
	KGQ11347.1	Fun_3
	KGK39536.1	Fun_4
	EPE08492.1	Fun_5
	YP_002049425.1	Pro_1
	CCF72996.1	Pro_2
	XP_008914162.1	Pro_3
	XP_002499891.1	Pro_4
	XP_002997444.1	Pro_5
	XP_002966250.1	Pla_1
	XP_004297956.1	Pla_2
	XP_010464585.1	Pla_3
	XP_002310663.1	Pla_4
	XP_002960579.1	Pla_5
	YP_001330666.1	Arc_1
	YP_004577128.1	Arc_2
	YP_001324133.1	Arc_3
	NP_987577.1	Arc_4
	YP_004742098.1	Arc_5
	YP_004051077.1	Eub_1
	YP_005097518.1	Eub_2
	YP_003497009.1	Eub_3
	KHE92173.1	Eub_4
	WP_008695554.1	Eub_5
	YP_003967466.1	Eub_6
	YP_003804037.1	Eub_7
	WP_020613878.1	Eub_8
	WP_023050069.1	Eub_9
	YP_004602945.1	Eub_10
maker-scaffold6957_size11554-snap-gene-0.14	XP_007330372.1	Fun_1
	XP_006459325.1	Fun_2
	KFA62214.1	Fun_3
	XP_004333766.1	Pro_1
	WP_011020160.1	Arc_1
	AHL21712.1	Arc_2
	WP_014787927.1	Arc_3

	KDE54630.1	Arc_4
	WP_004037443.1	Arc_5
	AHL22815.1	Arc_6
	WP_013683942.1	Arc_7
	WP_018154833.1	Arc_8
	KDE56031.1	Arc_9
	WP_007043923.1	Arc_10
	WP_027713684.1	Eub_1
	YP_004863204.1	Eub_2
	YP_007094641.1	Eub_3
	YP_001276859.1	Eub_4
	YP_004660744.1	Eub_5
maker-scaffold7284_size11211-snap-gene-0.10	NP_248482.1	Arc_1
	YP_003458392.1	Arc_2
	YP_003668298.1	Arc_3
	WP_023845917.1	Arc_4
	YP_002307070.1	Arc_5
	WP_008547787.1	Eub_1
	YP_005097508.1	Eub_2
	WP_019952117.1	Eub_3
	YP_005083038.1	Eub_4
	WP_029480120.1	Eub_5
	WP_019995162.1	Eub_6
	WP_019586149.1	Eub_7
	YP_005097712.1	Eub_8
	YP_002940899.1	Eub_9
	ETP70520.1	Eub_10
snap_masked-scaffold8624_size10011-processed-gene-0.6	XP_005805776.1	Met_1
	XP_008394756.1	Met_2
	XP_004081219.1	Met_3
	XP_002600037.1	Met_4
	XP_002166751.1	Met_5
	NP_610308.2	D_mel
	NP_506570.1	C_ele
	EKC30553.1	C_gig
	XP_006817025.1	S_kow
	XP_421193.1	G_gal
	XP_001639113.1	N_vec
	EPB85547.1	Fun_1
	EIE85905.1	Fun_2
	ERZ95212.1	Fun_3
	KFH72802.1	Fun_4
	CCX04229.1	Fun_5
	XP_008905649.1	Pro_1
	XP_008905636.1	Pro_2

	XP_008607143.1	Pro_3
	KDO35686.1	Pro_4
	XP_009520519.1	Pro_5
	CDP12036.1	Pla_1
	XP_009340056.1	Pla_2
	NP_001242868.1	Pla_3
	XP_009350917.1	Pla_4
	AFK43129.1	Pla_5
	WP_009377807.1	Arc_1
	WP_008384804.1	Arc_2
	WP_004969557.1	Arc_3
	YP_004036030.1	Arc_4
	WP_004062390.1	Arc_5
	WP_008575891.1	Arc_6
	YP_003536606.1	Arc_7
	WP_007275314.1	Arc_8
	WP_008095241.1	Arc_9
	WP_008427553.1	Arc_10
	YP_003392872.1	Eub_1
	YP_003299425.1	Eub_2
	CEG30478.1	Eub_3
	KFN08388.1	Eub_4
	YP_001959196.1	Eub_5
maker-scaffold7913-snap-gene-0.8	XP_004144976.1	Pla_1
	KEH16990.1	Pla_2
	XP_010239583.1	Pla_3
	XP_009388207.1	Pla_4
	KGN47269.1	Pla_5
	XP_008645343.1	Pla_6
	KEH17348.1	Pla_7
	KDO39227.1	Pla_8
	XP_003614397.1	Pla_9
	XP_008664051.1	Pla_10
	WP_004837891.1	Eub_1
	WP_021994825.1	Eub_2
	EZU73576.1	Eub_3
	CDW61305.1	Met_1
	KFD59988.1	Met_2
	CDI98843.1	Met_3
	CDS25675.1	Met_4
	CDS25763.1	Met_5
	CDQ01417.1	Met_6
	XP_003370857.1	Met_7
	CCI50950.1	Pro_1
	XP_009539700.1	Pro_2

	XP_008881610.1	Pro_3
	XP_005855606.1	Pro_4
	CBJ33763.1	Pro_5
	EJK58439.1	Pro_6
	EJY66653.1	Pro_7
	EJY65597.1	Pro_8
	CDW75723.1	Pro_9
	XP_009037769.1	Pro_10
snap_masked-scaffold9447_size9412-processed-gene-0.6	XP_004431947.1	Met_1
	XP_006872217.1	Met_2
	XP_004717516.1	Met_3
	XP_004271695.1	Met_4
	XP_006211575.1	Met_5
	NP_733183.1	D_mel
	NP_741083.1	C_ele
	EKC37583.1	C_gig
	XP_002730825.1	S_kow
	NP_990000.1	G_gal
	XP_001639716.1	N_vec
	XP_001271754.1	Fun_1
	EYE99742.1	Fun_2
	NP_594582.1	Fun_3
	XP_002562117.1	Fun_4
	KFY73827.1	Fun_5
	XP_002776755.1	Pro_1
	CCW63390.1	Pro_2
	XP_008862815.1	Pro_3
	EJY79302.1	Pro_4
	CCI41049.1	Pro_5
	XP_002982106.1	Pla_1
	AIL24123.1	Pla_2
	EYU29514.1	Pla_3
	XP_004293797.1	Pla_4
	XP_006354427.1	Pla_5
	WP_020863737.1	Arc_1
	WP_007109524.1	Arc_2
	WP_014863331.1	Arc_3
	CDK39042.1	Arc_4
	WP_006433147.1	Arc_5
	WP_018132764.1	Eub_1
	EWG10330.1	Eub_2
	WP_028397584.1	Eub_3
	WP_026567516.1	Eub_4
	WP_019122321.1	Eub_5
	WP_026041785.1	Eub_6

	AHV96308.1	Eub_7
	WP_033844031.1	Eub_8
	WP_031410118.1	Eub_9
	WP_033022690.1	Eub_10
maker-scaffold100_size92086-snap-gene-0.59	XP_001965764.1	Met_1
	XP_004208221.1	Met_2
	XP_004210584.1	Met_3
	CDQ74194.1	Met_4
	XP_008182148.1	Met_5
	EXX54610.1	Fun_1
	EXX71234.1	Fun_2
	EXX77471.1	Fun_3
	EXX60617.1	Fun_4
	ERZ95335.1	Fun_5
	EXX55650.1	Fun_6
	EXX71964.1	Fun_7
	XP_007768175.1	Fun_8
	EXX75000.1	Fun_9
	EXX67829.1	Fun_10
	ETK82390.1	Pro_1
	ETM45973.1	Pro_2
	XP_002905980.1	Pro_3
	XP_009534719.1	Pro_4
	ETL88842.1	Pro_5
	XP_008647179.1	Pla_1
	XP_003611303.1	Pla_2
	XP_008441705.1	Pla_3
	XP_008675648.1	Pla_4
	XP_006828689.1	Pla_5
augustus_masked-scaffold1002_size32014-processed-gene-0.4	CDW58869.1	Met_1
	XP_002412211.1	Met_2
	ELT98791.1	Met_3
	KFB45413.1	Met_4
	XP_001600500.3	Met_5
	NP_001097800.1	D_mel
	NP_495761.2	C_ele
	EKC37511.1	C_gig
	XP_006819255.1	S_kow
	NP_001004370.1	G_gal
	XP_001632486.1	N_vec
	XP_006675041.1	Fun_1
	CAI54276.1	Fun_2
	CDS03250.1	Fun_3
	KFH72372.1	Fun_4
	AGO45862.1	Fun_5

	XP_006969358.1	Fun_6
	KEY81006.1	Fun_7
	XP_752458.1	Fun_8
	XP_006695675.1	Fun_9
	KFH65919.1	Fun_10
	XP_005835793.1	Pro_1
	CCI10344.1	Pro_2
	ETM00112.1	Pro_3
	XP_008604566.1	Pro_4
	XP_008615359.1	Pro_5
	NP_001130547.1	Pla_1
	CDY68393.1	Pla_2
	XP_004500249.1	Pla_3
	XP_007016118.1	Pla_4
	KEH34256.1	Pla_5
	AIF19380.1	Arc_1
	WP_013719253.1	Arc_2
	WP_012899337.1	Arc_3
	WP_013329202.1	Arc_4
	KCZ72341.1	Arc_5
	AHF06106.1	Eub_6
	WP_021803882.1	Eub_7
	YP_004968539.1	Eub_8
	YP_003639472.1	Eub_9
	YP_004518633.1	Eub_10
augustus_masked-scaffold10141_size8958-processed-gene-0.1	XP_001635316.1	Met_1
	XP_009435878.1	Met_2
	XP_001625497.1	N_vec
	GAA87885.1	Fun_1
	KFH63080.1	Fun_2
	CEJ86814.1	Fun_3
	XP_008084311.1	Fun_4
	XP_001886371.1	Fun_5
	XP_002561833.1	Fun_6
	CEJ90243.1	Fun_7
	KFG79844.1	Fun_8
	XP_001875527.1	Fun_9
	CDO68660.1	Fun_10
	XP_008619938.1	Pro_1
	XP_008612269.1	Pro_2
	KDO34045.1	Pro_3
	EFA75896.1	Pro_4
	XP_008864995.1	Pro_5
	XP_001783997.1	Pla_1
	WP_021219852.1	Eub_1

	WP_031532596.1	Eub_2
	KFF04636.1	Eub_3
	YP_006434332.1	Eub_4
	YP_007059441.1	Eub_5
maker-scaffold104_size84685-augustus-gene-0.25	XP_001662061.1	Met_1
	XP_001334403.2	Met_2
	XP_007238911.1	Met_3
	XP_002426005.1	Met_4
	ERG83250.1	Met_5
	EKC23290.1	C_gig
	XP_002738912.1	S_kow
	CAG32330.1	G_gal
	XP_001627527.1	N_vec
	EXX67466.1	Fun_1
	ERZ98239.1	Fun_2
	EXX64054.1	Fun_3
	EXX64053.1	Fun_4
	ESA22219.1	Fun_5
	EXX55225.1	Fun_6
	ESA22357.1	Fun_7
	EXX78894.1	Fun_8
	EPE05478.1	Fun_9
	EXX78161.1	Fun_10
	XP_642017.1	Pro_1
	XP_003290267.1	Pro_2
	XP_003286087.1	Pro_3
	XP_004361490.1	Pro_4
	XP_004366680.1	Pro_5
	XP_001768654.1	Pla_1
	XP_001778634.1	Pla_2
	XP_008338155.1	Pla_3
	CDY51560.1	Pla_4
	XP_006430002.1	Pla_5
	WP_011278022.1	Arc_1
	4IHQ_A	Arc_2
	WP_013718158.1	Arc_3
	WP_011225183.1	Arc_4
	WP_009989409.1	Arc_5
	EEH95729.1	Eub_1
	WP_007372230.1	Eub_2
	WP_022091661.1	Eub_3
	WP_021977185.1	Eub_4
	WP_025486789.1	Eub_5
maker-scaffold1055_size34456-augustus-gene-0.19	NP_504814.1	Met_1
	XP_002596094.1	Met_2

	AFV15454.1	Met_3
	NP_001091293.1	Met_4
	XP_002632079.1	Met_5
	AAB17283.1	D_mel
	NP_001255596.1	C_ele
	EKC23483.1	C_gig
	XP_002739828.1	S_kow
	NP_990221.1	G_gal
	KDR72546.1	Fun_1
	XP_001884841.1	Fun_2
	XP_007333711.1	Fun_3
	XP_007263537.1	Fun_4
	XP_002910275.1	Fun_5
	XP_007313627.1	Fun_6
	XP_006463956.1	Fun_7
	EMD34865.1	Fun_8
	BAJ04704.1	Fun_9
	KDQ10248.1	Fun_10
	XP_004357764.1	Pro_1
	XP_003284991.1	Pro_2
	EFA78019.1	Pro_3
	XP_644535.1	Pro_4
	XP_004344552.1	Pro_5
	BAJ91418.1	Pla_1
	XP_008227235.1	Pla_2
	XP_004288836.1	Pla_3
	XP_006406907.1	Pla_4
	XP_007212738.1	Pla_5
	AIF11336.1	Arc_1
	AIF01706.1	Arc_2
	EHR76326.1	Arc_3
	CEE11519.1	Eub_1
	KER10060.1	Eub_2
	WP_014244994.1	Eub_3
	KHD88229.1	Eub_4
	WP_002773346.1	Eub_5
maker-scaffold10741_size8634-snap-gene-0.6	no hits	
snap_masked-scaffold10791_size8602-processed-gene-0.2	no hits	
maker-scaffold1092_size30908-snap-gene-0.25	no hits	
maker-scaffold1114_size30693-snap-gene-0.20	XP_002412211.1	Met_1
	CDW58869.1	Met_2
	XP_008557991.1	Met_3
	XP_002070486.1	Met_4
	KFB45413.1	Met_5
	NP_001097800.1	D_mel

	NP_508784.1	C_ele
	EKC37511.1	C_gig
	XP_002736983.1	S_kow
	NP_989795.1	G_gal
	XP_001632486.1	N_vec
	XP_006675041.1	Fun_1
	KFH72372.1	Fun_2
	CBY77922.1	Fun_3
	CEG84518.1	Fun_4
	AGM18795.1	Fun_5
	KGQ02839.1	Fun_6
	KHJ35111.1	Fun_7
	XP_008602503.1	Fun_8
	EPB81245.1	Fun_9
	CAI54276.1	Fun_10
	XP_005826511.1	Pro_1
	XP_008604566.1	Pro_2
	CCI10344.1	Pro_3
	XP_008900549.1	Pro_4
	XP_005828005.1	Pro_5
	NP_001130547.1	Pla_1
	CAN68179.1	Pla_2
	XP_010030862.1	Pla_3
	XP_002314106.1	Pla_4
	XP_006848199.1	Pla_5
	WP_013329202.1	Arc_1
	WP_023992546.1	Arc_2
	WP_015052990.1	Arc_3
	KCZ72341.1	Arc_4
	WP_012964887.1	Arc_5
	WP_015311955.1	Eub_1
	WP_011697598.1	Eub_2
	WP_013809672.1	Eub_3
	WP_013378647.1	Eub_4
	WP_018702598.1	Eub_5
maker-scaffold1218_size29458-augustus-gene-0.15	XP_003087518.1	Met_1
	XP_003494242.1	Met_2
	XP_003087253.1	Met_3
	XP_006572634.1	Met_4
	AET07638.1	D_mel
	NP_493642.1	C_ele
	EKC35130.1	C_gig
	XP_002835661.1	Fun_1
	XP_002146366.1	Fun_2
	KEQ95620.1	Fun_3

	CCX04382.1	Fun_4
	XP_007681732.1	Fun_5
	XP_002582987.1	Fun_6
	XP_001594706.1	Fun_7
	XP_007782065.1	Fun_8
	XP_001213488.1	Fun_9
	XP_003851279.1	Fun_10
	XP_001581214.1	Pro_1
	XP_001318849.1	Pro_2
	XP_001307179.1	Pro_3
	XP_001313378.1	Pro_4
	ESL05032.1	Pro_5
	XP_001786771.1	Pla_1
	XP_009350059.1	Pla_2
	XP_004153096.1	Pla_3
	XP_004150450.1	Pla_4
	AAT46463.1	Pla_5
	WP_011447997.1	Arc_1
	WP_006107949.1	Arc_2
	WP_026178011.1	Arc_3
	WP_013644835.1	Arc_4
	WP_021058250.1	Arc_5
	WP_010864105.1	Eub_1
	EUJ18999.1	Eub_2
	WP_003770993.1	Eub_3
	WP_026676254.1	Eub_4
	WP_021259541.1	Eub_5
snap_masked-scaffold1229_size29343-processed-gene-0.12	ELT89484.1	Met_1
	XP_008189204.1	Met_2
	XP_004210003.1	Met_3
	XP_003252027.1	Met_4
	XP_008010030.1	Met_5
	EFX05599.1	Fun_1
	XP_007386223.1	Fun_2
	KFX93406.1	Fun_3
	KGO46259.1	Fun_4
	XP_001273792.1	Fun_5
	EME42006.1	Fun_6
	EKG22580.1	Fun_7
	GAD96370.1	Fun_8
	XP_007584845.1	Fun_9
	XP_002481616.1	Fun_10
	XP_004351783.1	Pro_1
	EFA76876.1	Pro_2
	XP_004357599.1	Pro_3

	EFA81931.1	Pro_4
	CDI84718.1	Pro_5
	XP_002536383.1	Pla_1
	XP_006433080.1	Pla_2
	XP_009145312.1	Pla_3
	XP_004150799.1	Pla_4
	XP_004135660.1	Pla_5
	WP_015302305.1	Arc_1
	WP_007693300.1	Arc_2
	WP_011034822.1	Arc_3
	WP_009365802.1	Arc_4
	WP_012034641.1	Arc_5
	WP_012925026.1	Eub_1
	WP_026449801.1	Eub_2
	WP_009195208.1	Eub_3
	WP_012324524.1	Eub_4
	WP_020407949.1	Eub_5
augustus_masked-scaffold1669_size25481-processed-gene-0.3	EFX73537.1	Met_1
	EFX90311.1	Met_2
	KFH65094.1	Fun_1
	EQL38503.1	Fun_2
	EGC45789.1	Fun_3
	XP_003709515.1	Fun_4
	XP_006962669.1	Fun_5
	XP_005648551.1	Pro_1
	EFA78705.1	Pro_2
	XP_640495.2	Pro_3
	XP_005829071.1	Pro_4
	KDO28577.1	Pro_5
	XP_008244013.1	Pla_1
	XP_006279531.1	Pla_2
	KFK31719.1	Pla_3
	XP_008374728.1	Pla_4
	XP_002515916.1	Pla_5
	CBI23616.3	Pla_6
	XP_010481865.1	Pla_7
	XP_008385722.1	Pla_8
	XP_009348085.1	Pla_9
	KFK25558.1	Pla_10
	WP_018035917.1	Arc_1
	WP_019163754.1	Eub_1
	WP_014295917.1	Eub_2
	WP_003890357.1	Eub_3
	WP_026518421.1	Eub_4
	WP_022304042.1	Eub_5

snap_masked-scaffold2358_size21708-processed-gene-0.4	EFX90311.1	Met_1
	EFX73537.1	Met_2
	KFH65094.1	Fun_1
	EER44529.1	Fun_2
	EPS98363.1	Fun_3
	XP_010759782.1	Fun_4
	XP_007797619.1	Fun_5
	XP_640495.2	Pro_1
	XP_005648551.1	Pro_2
	EFA78705.1	Pro_3
	XP_003283190.1	Pro_4
	XP_004358933.1	Pro_5
	XP_002671820.1	Pla_1
	XP_006299070.1	Pla_2
	XP_010468470.1	Pla_3
	XP_004301068.1	Pla_4
	KFK25559.1	Pla_5
	BAB02888.1	Pla_6
	XP_010490121.1	Pla_7
	XP_009596006.1	Pla_8
	XP_006299602.1	Pla_9
	XP_004299227.1	Pla_10
	WP_018035917.1	Arc_1
	WP_019163754.1	Eub_1
	WP_015554366.1	Eub_2
	KFZ25997.1	Eub_3
	WP_022213626.1	Eub_4
	WP_003890357.1	Eub_5
maker-scaffold301_size53378-augustus-gene-0.31	EFX90311.1	Met_1
	EFX73537.1	Met_2
	XP_798930.2	Met_3
	KFH65094.1	Fun_1
	EEH10820.1	Fun_2
	XP_010759782.1	Fun_3
	EPS98363.1	Fun_4
	EEQ88435.1	Fun_5
	XP_640495.2	Pro_1
	XP_005648551.1	Pro_2
	EFA78705.1	Pro_3
	XP_002671820.1	Pro_4
	XP_008612699.1	Pro_5
	XP_002883559.1	Pla_1
	XP_006299070.1	Pla_2
	XP_004301068.1	Pla_3
	KFK25559.1	Pla_4

	NP_189122.1	Pla_5
	XP_010490121.1	Pla_6
	NP_196825.1	Pla_7
	XP_009596006.1	Pla_8
	XP_004299227.1	Pla_9
	XP_008244015.1	Pla_10
	WP_018035917.1	Arc_1
	WP_015554366.1	Eub_2
	KFZ25997.1	Eub_3
	WP_003890357.1	Eub_4
	WP_022213626.1	Eub_5
maker-scaffold3259_size18493-snap-gene-0.15	EFX73537.1	Met_1
	EFX90311.1	Met_2
	EFX73673.1	Met_3
	KFH65094.1	Fun_1
	EMT60789.1	Fun_2
	EEH10820.1	Fun_3
	EHK50424.1	Fun_4
	XP_002583201.1	Fun_5
	XP_004358933.1	Pro_1
	XP_640495.2	Pro_2
	KDO33253.1	Pro_3
	XP_008612536.1	Pro_4
	EFA78705.1	Pro_5
	XP_008812490.1	Pla_1
	XP_006365776.1	Pla_2
	XP_006402029.1	Pla_3
	KCW60647.1	Pla_4
	XP_007211020.1	Pla_5
	XP_002980512.1	Pla_6
	CBI38184.3	Pla_7
	CDY22349.1	Pla_8
	NP_001058232.1	Pla_9
	XP_010481865.1	Pla_10
	WP_018035917.1	Arc_1
	WP_019163754.1	Eub_1
	WP_022229781.1	Eub_2
	WP_027870105.1	Eub_3
	WP_014295917.1	Eub_4
	WP_013485158.1	Eub_5
maker-scaffold5591_size22739-augustus-gene-0.10	EFX73537.1	Met_1
	EFX90311.1	Met_2
	XP_003775165.1	Met_3
	KFH65094.1	Fun_1
	EEH10820.1	Fun_2

	XP_010759782.1	Fun_3
	XP_002789744.1	Fun_4
	EFW17364.1	Fun_5
	XP_005648551.1	Pro_1
	XP_004358933.1	Pro_2
	EFA78705.1	Pro_3
	XP_002671820.1	Pro_4
	KDO28577.1	Pro_5
	CDY60899.1	Pla_1
	XP_010494325.1	Pla_2
	XP_006279531.1	Pla_3
	XP_002863659.1	Pla_4
	XP_006403245.1	Pla_5
	XP_009596006.1	Pla_6
	XP_004299227.1	Pla_7
	XP_006419628.1	Pla_8
	XP_010522481.1	Pla_9
	XP_010243133.1	Pla_10
	WP_018035917.1	Arc_1
	WP_019163754.1	Eub_1
	WP_015554366.1	Eub_2
	WP_014295917.1	Eub_3
	WP_031542772.1	Eub_4
	WP_022213626.1	Eub_5
maker-scaffold7537_size10937-snap-gene-0.9	no hits	
augustus_masked-scaffold847_size34339-processed-gene-0.4	EFX73537.1	Met_1
	EFX90311.1	Met_2
	KFH65094.1	Fun_1
	EQL38503.1	Fun_2
	XP_003709515.1	Fun_3
	XP_006962669.1	Fun_4
	XP_002583201.1	Fun_5
	XP_005648551.1	Pro_1
	EFA78705.1	Pro_2
	XP_640495.2	Pro_3
	XP_005829071.1	Pro_4
	KDO28577.1	Pro_5
	XP_008244013.1	Pla_1
	XP_006279531.1	Pla_2
	KFK31719.1	Pla_3
	XP_008374728.1	Pla_4
	XP_002515916.1	Pla_5
	CBI23616.3	Pla_6
	XP_010481865.1	Pla_7
	XP_008385722.1	Pla_8

	XP_009348085.1	Pla_9
	XP_010522481.1	Pla_10
	WP_018035917.1	Arc_1
	WP_019163754.1	Eub_1
	WP_014295917.1	Eub_2
	WP_003890357.1	Eub_3
	WP_026518421.1	Eub_4
	WP_022304042.1	Eub_5
maker-scaffold10_size447749-snap-gene-2.50	XP_003494297.1	Met_1
	XP_002401716.1	Met_2
	4KCA_A	Met_3
	CDW58502.1	Met_4
	XP_003747944.1	Met_5
	NP_572212.1	D_mel
	NP_001256208.1	C_ele
	EKC21560.1	C_gig
	XP_006822377.1	S_kow
	XP_001620462.1	G_gal
	NP_990784.1	N_vec
	ESZ95345.1	Fun_1
	BAO41368.1	Fun_2
	XP_001523405.1	Fun_3
	CCU97737.1	Fun_4
	XP_719372.1	Fun_5
	XP_001698467.1	Pro_1
	YP_008965792.1	Pro_2
	CBJ27065.1	Pro_3
	XP_005706177.1	Pro_4
	XP_005838337.1	Pro_5
	XP_002456987.1	Pla_1
	XP_010537268.1	Pla_2
	AGT16574.1	Pla_3
	XP_010063856.1	Pla_4
	XP_004496464.1	Pla_5
	WP_011696309.1	Arc_1
	WP_004266945.1	Arc_2
	WP_012617691.1	Arc_3
	WP_005558848.1	Arc_4
	WP_008012525.1	Arc_5
	WP_013688259.1	Eub_1
	WP_013666464.1	Eub_2
	WP_029331895.1	Eub_3
	WP_010518977.1	Eub_4
	WP_028890024.1	Eub_5
	WP_027065741.1	Eub_6

	WP_008244206.1	Eub_7
	WP_027412590.1	Eub_8
	WP_012794719.1	Eub_9
	WP_025763979.1	Eub_10
maker-scaffold10072_size9001-snap-gene-0.11	EFX60142.1	Met_1
	XP_008189189.1	Met_2
	XP_002806096.1	Met_3
	XP_008189318.1	Met_4
	XP_003731889.1	Met_5
	KGQ13328.1	Fun_1
	KGQ13007.1	Fun_2
	KGQ02324.1	Fun_3
	XP_003343047.1	Fun_4
	ELR02842.1	Fun_5
	XP_002536388.1	Pla_1
	XP_004150795.1	Pla_2
	XP_002534793.1	Pla_3
	XP_004151615.1	Pla_4
	XP_002536543.1	Pla_5
	AIF12159.1	Arc_2
	KGM41405.1	Eub_1
	KFB77454.1	Eub_2
	WP_018077583.1	Eub_3
	WP_011764342.1	Eub_4
	WP_011112626.1	Eub_5
	WP_015833036.1	Eub_6
	WP_004307530.1	Eub_7
	WP_013149194.1	Eub_8
	WP_015829816.1	Eub_9
	WP_027457926.1	Eub_10
augustus_masked-scaffold634_size55776-processed-gene-0.11	XP_003738667.1	Met_1
	ETN82745.1	Met_2
	ELU02595.1	Met_3
	XP_008188580.1	Met_4
	XP_003390062.1	Met_5
	XP_751388.1	Fun_1
	XP_001266605.1	Fun_2
	GAD97714.1	Fun_3
	XP_001800184.1	Fun_4
	XP_007830094.1	Fun_5
	AGN55416.1	Pro_1
	CBJ29121.1	Pro_2
	XP_009311423.1	Pro_3
	EWM26995.1	Pro_4
	XP_005776122.1	Pro_5

	XP_004151165.1	Pla_1
	XP_004150801.1	Pla_2
	XP_004153282.1	Pla_3
	XP_002538957.1	Pla_4
	XP_002536519.1	Pla_5
	AAS80142.1	Arc_1
	WP_022540841.1	Arc_2
	WP_026177860.1	Arc_3
	AIJ06331.1	Arc_4
	WP_015017668.1	Arc_5
	GAK50919.1	Eub_1
	EZP35449.1	Eub_2
	WP_012829633.1	Eub_3
	WP_017876566.1	Eub_4
	KGG72191.1	Eub_5
	KEZ76615.1	Eub_6
	WP_006634116.1	Eub_7
	WP_026265016.1	Eub_8
	KFC11132.1	Eub_9
	WP_013839871.1	Eub_10
maker-scaffold1864_size33177-snap-gene-0.15	XP_002936263.2	Met_1
	XP_005058356.1	Met_2
	XP_010721642.1	Met_3
	XP_006264954.1	Met_4
	XP_005529981.1	Met_5
	XP_003642627.2	G_gal
	KGQ11337.1	Fun_1
	XP_007847524.1	Fun_2
	XP_008035226.1	Fun_3
	XP_002487065.1	Fun_4
	EKV12168.1	Fun_5
	XP_001582566.1	Pro_1
	XP_003288844.1	Pro_2
	EFA83248.1	Pro_3
	ETO69210.1	Pro_4
	CCA27737.1	Pro_5
	XP_009622673.1	Pla_1
	XP_003559419.1	Pla_2
	XP_009138723.1	Pla_3
	XP_006293189.1	Pla_4
	CDP09158.1	Pla_5
	WP_008525790.1	Arc_1
	WP_004052441.1	Arc_2
	WP_008388568.1	Arc_3
	WP_014514219.1	Arc_4

	WP_023395855.1	Arc_5
	ADC36136.1	Eub_1
	WP_033378084.1	Eub_2
	KER10627.1	Eub_3
	WP_006309209.1	Eub_4
	WP_027311271.1	Eub_5
	AGA60127.1	Eub_6
	WP_018280194.1	Eub_7
	WP_033073909.1	Eub_8
	WP_013634099.1	Eub_9
	WP_025863140.1	Eub_10
maker-scaffold2739_size20194-snap-gene-0.9	XP_005099835.1	Met_1
	EGT36150.1	Met_2
	ETN85160.1	Met_3
	ELT98931.1	Met_4
	EYC08769.1	Met_5
	NP_001024899.1	C_ele
	EKC19968.1	C_gig
	XP_002734727.1	S_kow
	XP_001231457.2	G_gal
	XP_007831537.1	Fun_1
	KFH48506.1	Fun_2
	XP_658924.1	Fun_3
	KFA62644.1	Fun_4
	KGQ13279.1	Fun_5
	XP_005768404.1	Pro_1
	EWM25928.1	Pro_2
	XP_001432411.1	Pro_3
	EWM29697.1	Pro_4
	XP_625638.1	Pro_5
	XP_002536305.1	Pla_1
	CDP00545.1	Pla_2
	XP_001759460.1	Pla_3
	XP_010477896.1	Pla_4
	XP_010551319.1	Pla_5
	WP_012186262.1	Arc_1
	WP_015789392.1	Arc_2
	WP_013881653.1	Arc_3
	WP_006665629.1	Arc_4
	WP_023392761.1	Arc_5
	WP_014267536.1	Eub_1
	CDG83135.1	Eub_2
	WP_014266599.1	Eub_3
	WP_002652980.1	Eub_4
	BAL53258.1	Eub_5

	WP_011682943.1	Eub_6
	WP_010586830.1	Eub_7
	WP_028056784.1	Eub_8
	WP_032750987.1	Eub_9
	WP_020719291.1	Eub_10
maker-scaffold5875_size12964-augustus-gene-0.12	XP_008119646.1	Met_1
	XP_005439707.1	Met_2
	XP_009566128.1	Met_3
	XP_010574610.1	Met_4
	XP_010721642.1	Met_5
	EKC22647.1	C_gig
	XP_006823392.1	S_kow
	XP_003642627.2	G_gal
	KGQ11337.1	Fun_1
	KEQ89829.1	Fun_2
	XP_007926532.1	Fun_3
	XP_002565392.1	Fun_4
	XP_007267977.1	Fun_5
	XP_001582566.1	Pro_1
	XP_629427.1	Pro_2
	EFA83248.1	Pro_3
	XP_004338410.1	Pro_4
	CBN79266.1	Pro_5
	XP_002538818.1	Pla_1
	XP_004151490.1	Pla_2
	XP_010253611.1	Pla_3
	CBI19138.3	Pla_4
	EYU23226.1	Pla_5
	WP_020936057.1	Arc_1
	WP_004052441.1	Arc_2
	WP_015788806.1	Arc_3
	WP_014514219.1	Arc_4
	WP_013303407.1	Arc_5
	ADC36136.1	Eub_1
	WP_012936867.1	Eub_2
	WP_014855432.1	Eub_3
	WP_007224926.1	Eub_4
	WP_029286826.1	Eub_5
	KER10627.1	Eub_6
	WP_013445511.1	Eub_7
	WP_015394375.1	Eub_8
	WP_025145736.1	Eub_9
	WP_020214487.1	Eub_10
maker-scaffold653_size38539-augustus-gene-0.27	XP_009017213.1	Met_1
	XP_001604463.1	Met_2

	4INE_A	Met_3
	EGI59206.1	Met_4
	XP_003690071.1	Met_5
	NP_728647.2	D_mel
	NP_504248.1	C_ele
	EKC35520.1	C_gig
	XP_002739709.1	S_kow
	XP_001232694.1	G_gal
	XP_001634000.1	N_vec
	XP_001593795.1	Fun_1
	EXL98237.1	Fun_2
	ESZ92947.1	Fun_3
	KFY71418.1	Fun_4
	XP_007831558.1	Fun_5
	XP_001580573.1	Pro_1
	XP_005713374.1	Pro_2
	XP_005773499.1	Pro_3
	CBN78409.1	Pro_4
	EWM24131.1	Pro_5
	XP_002968407.1	Pla_1
	XP_003579980.1	Pla_2
	XP_009348175.1	Pla_3
	EMT16365.1	Pla_4
	XP_008669256.1	Pla_5
	WP_012186229.1	Arc_1
	WP_007983554.1	Arc_2
	WP_013775078.1	Arc_3
	WP_012617787.1	Arc_4
	WP_006107239.1	Arc_5
	WP_010298206.1	Eub_1
	EKE10074.1	Eub_2
	WP_010298216.1	Eub_3
	CEG55859.1	Eub_4
	WP_019215882.1	Eub_5
	WP_016641614.1	Eub_6
	ABK51300.1	Eub_7
	WP_030668919.1	Eub_8
	CEG59739.1	Eub_9
	ABK51304.1	Eub_10
augustus_masked-scaffold16703_size5213-processed-gene-0.3	XP_002006305.1	Met_1
	AID66689.1	Met_2
	KFB50133.1	Met_3
	EGI61493.1	Met_4
	XP_001648219.1	Met_5
	NP_610910.1	D_mel

	NP_499156.1	C_ele
	EKC25144.1	C_gig
	XP_002733386.1	S_kow
	NP_001264324.1	G_gal
	XP_001632083.1	N_vec
	EPZ33336.1	Fun_1
	CDH51333.1	Fun_2
	KFH69078.1	Fun_3
	CEG78357.1	Fun_4
	XP_006677806.1	Fun_5
	XP_002896725.1	Pro_1
	XP_002185363.1	Pro_2
	XP_008619731.1	Pro_3
	XP_009827265.1	Pro_4
	XP_004361016.1	Pro_5
	XP_002978957.1	Pla_1
	XP_001776046.1	Pla_2
	ACN34888.1	Pla_3
	EMT23733.1	Pla_4
	XP_010693603.1	Pla_5
	WP_009989350.1	Arc_1
	WP_018031782.1	Arc_2
	BAK54799.1	Arc_3
	WP_012020349.1	Arc_4
	EZQ01785.1	Arc_5
	ADI23429.1	Eub_1
	WP_023785595.1	Eub_2
	WP_031310303.1	Eub_3
	WP_012334335.1	Eub_4
	WP_012115283.1	Eub_5
	WP_027314507.1	Eub_6
	WP_019403833.1	Eub_7
	KEO57881.1	Eub_8
	ADI22862.1	Eub_9
	CDI01830.1	Eub_10
snap_masked-scaffold15732_size5688-processed-gene-0.5	XP_005844806.1	Pro_1
	XP_001701647.1	Pro_2
	XP_003062187.1	Pro_3
	XP_002507857.1	Pro_4
	XP_005646648.1	Pro_5
	XP_010255398.1	Pla_1
	XP_007040225.1	Pla_2
	AFF18844.2	Pla_3
	XP_010053262.1	Pla_4
	XP_002965328.1	Pla_5

	WP_026069031.1	Arc_1
	WP_012067963.1	Arc_2
	WP_013719810.1	Arc_3
	WP_012107187.1	Arc_4
	WP_023788514.1	Eub_1
	WP_029349626.1	Eub_2
	GAK45010.1	Eub_3
	WP_018389422.1	Eub_4
	WP_025898136.1	Eub_5
	WP_008968192.1	Eub_6
	WP_019401656.1	Eub_7
	WP_012171491.1	Eub_8
	WP_024082207.1	Eub_9
	WP_020184280.1	Eub_10
maker-scaffold35_size141275-augustus-gene-0.60	XP_003087253.1	Met_1
	XP_006572634.1	Met_2
	XP_003494242.1	Met_3
	CDJ94564.1	Met_5
	AAR88535.1	D_mel
	NP_493662.1	C_ele
	EKC28549.1	C_gig
	XP_006823203.1	S_kow
	XP_424658.4	G_gal
	XP_001632614.1	N_vec
	CCU97940.1	Fun_1
	XP_002835661.1	Fun_2
	XP_002478659.1	Fun_3
	KEQ95620.1	Fun_4
	XP_007928828.1	Fun_5
	XP_007782065.1	Fun_6
	KEQ77816.1	Fun_7
	XP_001240362.1	Fun_8
	XP_007916978.1	Fun_9
	XP_003851279.1	Fun_10
	XP_001313378.1	Pro_1
	EKF37720.1	Pro_2
	XP_009527058.1	Pro_3
	XP_004338893.1	Pro_4
	XP_001786771.1	Pla_1
	XP_009350059.1	Pla_2
	XP_004153096.1	Pla_3
	AAT46463.1	Pla_4
	KEH25560.1	Pla_5
	WP_011447997.1	Arc_1
	WP_006107949.1	Arc_2

	WP_026178011.1	Arc_3
	WP_008417650.1	Arc_4
	WP_021050036.1	Arc_5
	WP_011701593.1	Eub_1
	WP_009883770.1	Eub_2
	WP_029519205.1	Eub_3
	WP_014096474.1	Eub_4
	WP_018978261.1	Eub_5
maker-scaffold6361_size12239-augustus-gene-0.6	KDR15437.1	Met_1
	XP_003699567.1	Met_2
	EFX81873.1	Met_3
	BAN67992.1	Met_4
	AHA15412.1	Met_5
	AAAY33507.1	D_mel
	NP_001255321.1	C_ele
	EKC34158.1	C_gig
	XP_006812248.1	S_kow
	XP_417192.4	G_gal
	XP_001621855.1	N_vec
	XP_007413493.1	Fun_1
	XP_007754244.1	Fun_2
	XP_007677021.1	Fun_3
	EPS45179.1	Fun_4
	EWC44178.1	Fun_5
	XP_007304919.1	Fun_6
	EGX44973.1	Fun_7
	KEF57337.1	Fun_8
	BAA24288.1	Fun_9
	XP_009551060.1	Fun_10
	XP_008873559.1	Pro_1
	XP_008621529.1	Pro_2
	XP_005717470.1	Pro_3
	ETP45559.1	Pro_4
	XP_008873560.1	Pro_5
	EAZ37398.1	Pla_1
	CBI24374.3	Pla_2
	EMS54718.1	Pla_3
	XP_008657378.1	Pla_4
	XP_010261207.1	Pla_5
	WP_009378229.1	Arc_1
	WP_006091359.1	Arc_2
	WP_007997629.1	Arc_3
	WP_013199551.1	Arc_4
	WP_008385348.1	Arc_5
	WP_020553760.1	Eub_1

	WP_020545881.1	Eub_2
	WP_014376096.1	Eub_3
	WP_010490673.1	Eub_4
	EZP77682.1	Eub_5
snap_masked-scaffold11172_size8401-processed-gene-0.10	XP_005296939.1	Met_1
	XP_003759590.1	Met_2
	EHJ65205.1	Met_3
	ERG78783.1	Met_4
	XP_007055214.1	Met_5
	XP_010022303.1	D_mel
	NP_499752.2	C_ele
	EKC36665.1	C_gig
	XP_002733329.1	S_kow
	NP_001006571.1	G_gal
	XP_001629906.1	N_vec
	KGQ06105.1	Fun_1
	XP_006680366.1	Fun_2
	CEG80401.1	Fun_3
	EPB91067.1	Fun_4
	KFH68662.1	Fun_5
	CCI48665.1	Pro_1
	XP_008896359.1	Pro_2
	XP_008875209.1	Pro_3
	XP_643924.1	Pro_4
	AFA43560.1	Pro_5
	XP_004151081.1	Pla_1
	XP_008380600.1	Pla_2
	CDX79511.1	Pla_3
	XP_007225742.1	Pla_4
	XP_009376354.1	Pla_5
	WP_018194565.1	Arc_1
	AIF16890.1	Arc_2
	AIY89150.1	Arc_3
	WP_006651380.1	Arc_4
	WP_010878693.1	Arc_5
	WP_018991769.1	Eub_1
	WP_019140074.1	Eub_2
	WP_008055001.1	Eub_3
	WP_003651130.1	Eub_4
	KHL68010.1	Eub_5
	WP_011236874.1	Eub_6
	WP_012696471.1	Eub_7
	KER68500.1	Eub_8
	WP_027823665.1	Eub_9
	WP_020676134.1	Eub_10

maker-scaffold1372_size27931-augustus-gene-0.18	XP_002652421.1	Fun_1
	XP_007693131.1	Fun_2
	EXK77392.1	Fun_3
	CCF36248.1	Fun_4
	EHK21831.1	Fun_5
	AIF84065.1	Arc_1
	WP_008415190.1	Arc_2
	WP_013328432.1	Arc_3
	AHG49912.1	Eub_1
	WP_013442119.1	Eub_2
	WP_012929377.1	Eub_3
	WP_026848803.1	Eub_4
	WP_028071295.1	Eub_5
	WP_016478841.1	Eub_6
	EWS60166.1	Eub_7
	WP_026211259.1	Eub_8
	WP_026224969.1	Eub_9
	WP_011659296.1	Eub_10
snap_masked-scaffold15974_size5576-processed-gene-0.4	GAA58079.1	Met_1
	CDQ06444.1	Met_2
	KII64380.1	Met_3
	KII60428.1	Met_4
	ESA04763.1	Fun_1
	XP_002778525.1	Pro_1
	XP_005714299.1	Pro_2
	XP_002261981.1	Pro_3
	YP_003734590.1	Pro_4
	ABV70075.1	Pro_5
	EEC77198.1	Pla_1
	XP_002539765.1	Pla_2
	CBI38526.3	Pla_3
	XP_002538226.1	Pla_4
	WP_018204489.1	Arc_1
	KHO49811.1	Arc_2
	KCZ72093.1	Arc_3
	KHO49864.1	Arc_4
	WP_008085101.1	Arc_5
	WP_011478777.1	Eub_1
	WP_025224447.1	Eub_2
	WP_036301985.1	Eub_3
	WP_024296699.1	Eub_4
	WP_019899701.1	Eub_5
	WP_029148793.1	Eub_6
	WP_013818233.1	Eub_7
	KFB74853.1	Eub_8

	WP_005372856.1	Eub_9
	AAK73287.1	Eub_10
snap_masked-scaffold21250_size3389-processed-gene-0.4	ETN71917.1	Met_1
	ELT98248.1	Met_2
	XP_009280520.1	Met_3
	CDW59419.1	Met_4
	EFX60659.1	Met_5
	XP_001621431.1	N_vec
	KGQ13765.1	Fun_1
	CCO32341.1	Fun_2
	XP_003034240.1	Fun_3
	CDS09559.1	Fun_4
	EJT48035.1	Fun_5
	EMH77043.1	Pro_1
	NP_050679.1	Pro_2
	YP_009019547.1	Pro_3
	YP_002049106.1	Pro_4
	YP_007627321.1	Pro_5
	XP_001786429.1	Pla_1
	XP_002536709.1	Pla_2
	XP_010423240.1	Pla_3
	Q9LYP5.3	Pla_4
	WP_007912399.1	Eub_1
	WP_012191727.1	Eub_2
	AIE84789.1	Eub_3
	WP_012548320.1	Eub_4
	WP_016483317.1	Eub_5
	WP_012257866.1	Eub_6
	WP_004094729.1	Eub_7
	WP_007932110.1	Eub_8
	WP_007290102.1	Eub_9
	WP_038669286.1	Eub_10
maker-scaffold5005_size27369-snap-gene-0.11	XP_001625497.1	N_vec
	EYE90242.1	Fun_1
	KFH63080.1	Fun_2
	KDQ07441.1	Fun_3
	EGX52233.1	Fun_4
	KDR69753.1	Fun_5
	KDQ08968.1	Fun_6
	EHA25061.1	Fun_7
	KFH74029.1	Fun_8
	XP_002584863.1	Fun_9
	KDR84407.1	Fun_10
	XP_008619938.1	Pro_1
	KDO34045.1	Pro_2

	KDO25464.1	Pro_3
	XP_008877743.1	Pro_4
	EFA75896.1	Pro_5
	XP_001783997.1	Pla_1
	WP_034340452.1	Eub_1
	WP_012240424.1	Eub_2
	WP_031532596.1	Eub_3
	WP_012234898.1	Eub_4
	WP_015159832.1	Eub_5
snap_masked-scaffold10028_size9034-processed-gene-0.12	EFX61835.1	Met_1
	XP_002399538.1	Met_2
	ETN82707.1	Met_3
	XP_003087310.1	Met_4
	XP_003248492.1	Met_5
	XP_001617728.1	N_vec
	KGQ11045.1	Fun_1
	XP_003343367.1	Fun_2
	XP_006683255.1	Fun_3
	KGQ13747.1	Fun_4
	KGQ13011.1	Fun_5
	YP_007878145.1	Pro_1
	YP_008144745.1	Pro_2
	YP_063524.1	Pro_3
	YP_007627306.1	Pro_4
	YP_009029538.1	Pro_5
	XP_002536382.1	Pla_1
	XP_004151145.1	Pla_2
	XP_002535661.1	Pla_3
	XP_004151325.1	Pla_4
	XP_002534694.1	Pla_5
	WP_013100526.1	Arc_1
	WP_011973413.1	Arc_2
	WP_015733022.1	Arc_3
	WP_011019850.1	Arc_4
	WP_011869438.1	Arc_5
	WP_034158682.1	Eub_1
	WP_017977919.1	Eub_2
	WP_029868197.1	Eub_3
	WP_010544673.1	Eub_4
	WP_033921186.1	Eub_5
	WP_010125067.1	Eub_6
	WP_011241478.1	Eub_7
	KHS46558.1	Eub_8
	WP_021224583.1	Eub_9
	WP_011444994.1	Eub_10

maker-scaffold15817_size10713-snap-gene-0.13	XP_003384219.1	Met_1
	XP_008188578.1	Met_2
	AEN94429.1	Met_3
	ACZ34284.1	Met_4
	KHN82288.1	Met_5
	KGQ13967.1	Fun_1
	XP_003350552.1	Fun_2
	XP_001877863.1	Fun_3
	KFH71571.1	Fun_4
	XP_003662939.1	Fun_5
	KFM23834.1	Pro_1
	XP_005644798.1	Pro_2
	XP_002780169.1	Pro_3
	CBK25268.2	Pro_4
	ADI46896.1	Pro_5
	XP_002972200.1	Pla_1
	XP_002518167.1	Pla_2
	XP_001757872.1	Pla_3
	XP_009758422.1	Pla_4
	XP_004239873.1	Pla_5
	AIF69214.1	Arc_1
	WP_004066086.1	Arc_2
	WP_018153845.1	Arc_3
	WP_011868217.1	Arc_4
	WP_010885242.1	Arc_5
	CEG56315.1	Eub_1
	CEG59884.1	Eub_2
	WP_010654134.1	Eub_3
	WP_014714452.1	Eub_4
	WP_018575757.1	Eub_5
	WP_011006174.1	Eub_6
	WP_014944796.1	Eub_7
	AHE67034.1	Eub_8
	WP_011096893.1	Eub_9
	WP_014943697.1	Eub_10
maker-scaffold4964_size23147-snap-gene-0.19	XP_001863560.1	Met_1
	XP_009859733.1	Met_2
	ETN64199.1	Met_3
	XP_005101843.1	Met_4
	XP_001655105.1	Met_5
	AAK93491.1	D_mel
	NP_505590.1	C_ele
	EKC23984.1	C_gig
	XP_006811586.1	S_kow
	NP_990423.1	G_gal

	XP_001627844.1	N_vec
	XP_007418648.1	Fun_1
	XP_007338082.1	Fun_2
	XP_008088124.1	Fun_3
	XP_007265168.1	Fun_4
	AEE37279.1	Fun_5
	XP_008710540.1	Fun_6
	CDS03471.1	Fun_7
	KFY32162.1	Fun_8
	CCM05158.1	Fun_9
	NP_595070.1	Fun_10
	XP_002951308.1	Pro_1
	CCA23797.1	Pro_2
	XP_005646096.1	Pro_3
	XP_001701046.1	Pro_4
	KFM26394.1	Pro_5
	XP_002966050.1	Pla_1
	XP_001764010.1	Pla_2
	XP_004151682.1	Pla_3
	XP_003630404.1	Pla_4
	CDO98669.1	Pla_5
	WP_023395609.1	Arc_1
	WP_004054285.1	Arc_2
	WP_006671834.1	Arc_3
	WP_013880559.1	Arc_4
	WP_008893704.1	Arc_5
	WP_008599630.1	Eub_1
	WP_015148708.1	Eub_2
	WP_027714125.1	Eub_3
	WP_015199377.1	Eub_4
	WP_015203442.1	Eub_5
maker-scaffold1195_size29765-augustus-gene-0.13	CCF36248.1	Fun_1
	EXK77392.1	Fun_2
	EQB47608.1	Fun_3
	KEF54943.1	Fun_4
	ERT01442.1	Fun_5
	WP_012694949.1	Eub_1
	WP_026224969.1	Eub_2
	EWS60166.1	Eub_3
	WP_012929377.1	Eub_4
	WP_011659296.1	Eub_5
	WP_032003234.1	Eub_6
	WP_013442119.1	Eub_7
	EWC91883.1	Eub_8
	AHG49912.1	Eub_9

	WP_028111420.1	Eub_10
augustus_masked-scaffold3707_size17255-processed-gene-0.4	XP_002111309.1	Met_1
	XP_003087040.1	Met_2
	EHJ77374.1	Met_3
	ELR04516.1	Fun_1
	KFA81525.1	Fun_2
	KFY27804.1	Fun_3
	XP_006679297.1	Fun_4
	EXX77460.1	Fun_5
	XP_005702535.1	Pro_1
	XP_005854422.1	Pro_2
	EJK75808.1	Pro_3
	CBN75524.1	Pro_4
	XP_009040352.1	Pro_5
	XP_002539044.1	Pla_1
	WP_013645432.1	Arc_1
	WP_013328829.1	Arc_2
	WP_011447903.1	Arc_3
	WP_015591536.1	Arc_4
	WP_011991228.1	Arc_5
	WP_035601819.1	Eub_1
	WP_007418610.1	Eub_2
	WP_012376477.1	Eub_3
	WP_020147014.1	Eub_4
	AHF89923.1	Eub_5
	WP_013043507.1	Eub_6
	WP_017315687.1	Eub_7
	WP_015137331.1	Eub_8
	WP_015126572.1	Eub_9
	WP_002650501.1	Eub_10
augustus_masked-scaffold5948_size12860-processed-gene-0.1	WP_010594873.1	Eub_1
	CDI81106.1	Pro_1
	XP_005111876.1	Met_1
maker-scaffold6486_size12099-snap-gene-0.18	XP_003390335.1	Met_1
	ELU12484.1	Met_2
	KGQ02393.1	Fun_1
	KGQ13406.1	Fun_2
	KGQ02342.1	Fun_3
	KGQ13404.1	Fun_4
	KGQ02394.1	Fun_5
	EEC76774.1	Pla_1
	XP_010911353.1	Pla_2
	WP_007541015.1	Arc_2
	WP_012944029.1	Arc_3
	WP_008607546.1	Arc_4

	WP_006055763.1	Arc_5
	WP_006018912.1	Eub_1
	WP_011471316.1	Eub_2
	All86748.1	Eub_3
	WP_012187081.1	Eub_4
	WP_015014915.1	Eub_5
	WP_020279833.1	Eub_6
	WP_018130303.1	Eub_7
	WP_037375066.1	Eub_8
	AFV25996.1	Eub_9
	WP_011288498.1	Eub_10
maker-scaffold936_size32981-augustus-gene-0.15	AFX93751.1	Met_1
	KDR09962.1	Met_2
	XP_003490817.1	Met_3
	XP_006614807.1	Met_4
	CDW60486.1	Met_5
	XP_001640909.1	N_vec
	EIF45432.1	Fun_1
	KGQ13002.1	Fun_2
	ELQ74691.1	Fun_3
	CEG65883.1	Fun_4
	KGG50167.1	Fun_5
	XP_002176228.1	Pro_1
	XP_009826895.1	Pro_2
	XP_002499746.1	Pro_3
	ETK94526.1	Pro_4
	XP_005651543.1	Pro_5
	XP_002539349.1	Pla_1
	XP_010520015.1	Pla_2
	XP_009601586.1	Pla_3
	XP_006399478.1	Pla_4
	AAL08291.1	Pla_5
	WP_006089579.1	Arc_1
	WP_007700009.1	Arc_2
	WP_008010667.1	Arc_3
	KDE59489.1	Arc_4
	AHG03927.1	Arc_5
	WP_027322509.1	Eub_1
	WP_019391572.1	Eub_2
	WP_034305480.1	Eub_3
	WP_018931782.1	Eub_4
	WP_013282559.1	Eub_5
	WP_014974776.1	Eub_6
	WP_023956523.1	Eub_7
	WP_019880535.1	Eub_8

	WP_036718162.1	Eub_9
	WP_011419514.1	Eub_10
maker-scaffold13328_size7081-snap-gene-0.6	XP_002593443.1	Met_1
	AFN10620.1	Met_2
	XP_004033436.1	Met_3
	XP_008963953.1	Met_4
	NP_525007.1	D_mel
	XP_001631296.1	C_ele
	XP_002735096.1	S_kow
	XP_426504.2	G_gal
	XP_001631296.1	N_vec
	XP_005761116.1	Pro_1
	XP_005649452.1	Pro_2
	KDO27278.1	Pro_3
	EJK73538.1	Pro_4
	XP_005649451.1	Pro_5
	BAK00429.1	Pla_1
	EMS60087.1	Pla_2
	ACN28695.1	Pla_3
	XP_006664936.1	Pla_4
	KDP27744.1	Pla_5
	WP_006165993.1	Arc_1
	WP_023844498.1	Arc_2
	Q8TTI0.2	Arc_3
	WP_011020504.1	Arc_4
	WP_035082641.1	Eub_1
	WP_033289318.1	Eub_2
	WP_026152055.1	Eub_3
	WP_007920028.1	Eub_4
	WP_028429931.1	Eub_5
maker-scaffold3315_size18320-snap-gene-0.10	ERG81996.1	Met_1
	XP_001897006.1	Met_2
	XP_003140874.1	Met_3
	XP_003031842.1	Met_4
	EJW80422.1	Met_5
	XP_003031842.1	Fun_1
	XP_001836593.2	Fun_2
	KDQ25016.1	Fun_3
	XP_007844786.1	Fun_4
	CCA71030.1	Fun_5
	XP_007508888.1	Pro_1
	XP_002508499.1	Pro_2
	XP_005704929.1	Pro_3
	XP_009042022.1	Pro_4
	XP_005844860.1	Pro_5

	B9NJI2.1	Pla_1
	XP_010023871.1	Pla_2
	EYU18298.1	Pla_3
	XP_006354455.1	Pla_4
	EPS70702.1	Pla_5
	ERH04195.1	Arc_1
	EGQ40327.1	Arc_2
	WP_010979030.1	Arc_3
	WP_012433147.1	Eub_1
	WP_012005966.1	Eub_2
	WP_020443882.1	Eub_3
	WP_007745917.1	Eub_4
	WP_012776286.1	Eub_5
	GAF60402.1	Eub_6
	WP_010808883.1	Eub_7
	WP_020204195.1	Eub_8
	WP_036846445.1	Eub_9
	WP_028834723.1	Eub_10
maker-scaffold301_size53378-augustus-gene-0.28	XP_002835661.1	Fun_1
	KEQ95620.1	Fun_2
	XP_007782065.1	Fun_3
	EYE97134.1	Fun_4
	XP_002478659.1	Fun_5
	XP_003851279.1	Fun_6
	XP_007928828.1	Fun_7
	XP_007916978.1	Fun_8
	XP_007804270.1	Fun_9
	XP_007681732.1	Fun_10
	WP_034515623.1	Eub_1
maker-scaffold12736_size7442-augustus-gene-0.15	XP_003391334.1	Met_1
	ELT99311.1	Met_2
	XP_002118984.1	Met_3
	XP_002411344.1	Met_4
	ETN83290.1	Met_5
	NP_730301.3	D_mel
	NP_506927.2	C_ele
	EKC17818.1	C_gig
	XP_006814548.1	S_kow
	CDM63411.1	G_gal
	XP_001618124.1	N_vec
	KGQ13492.1	Fun_1
	KGQ13060.1	Fun_2
	KGQ06042.1	Fun_3
	KGQ11395.1	Fun_4
	XP_006683391.1	Fun_5

	YP_009106192.1	Pro_1
	YP_009020823.1	Pro_2
	YP_003058285.1	Pro_3
	YP_009105588.1	Pro_4
	NP_045832.1	Pro_5
	Q9G4F5.1	Pla_1
	KEH15262.1	Pla_2
	AET49971.1	Pla_3
	AET49981.1	Pla_4
	AET49973.1	Pla_5
	WP_013413695.1	Arc_1
	WP_014866799.1	Arc_2
	WP_011306046.1	Arc_3
	KGK99254.1	Arc_4
	WP_012617740.1	Arc_5
	WP_012455626.1	Eub_1
	WP_035609984.1	Eub_2
	WP_006390394.1	Eub_3
	WP_027475316.1	Eub_4
	WP_012496813.1	Eub_5
	WP_025138012.1	Eub_6
	WP_028249628.1	Eub_7
	WP_010807914.1	Eub_8
	WP_009518683.1	Eub_9
	KCB36226.1	Eub_10
snap_masked-scaffold23_size182404-processed-gene-0.32	XP_003390005.1	Met_1
	AGG09876.1	Met_2
	XP_003493077.1	Met_3
	XP_003738673.1	Met_4
	GAA58105.1	Met_5
	XP_001639437.1	N_vec
	KDQ54527.1	Fun_1
	XP_007347977.1	Fun_2
	XP_007864003.1	Fun_3
	XP_007263351.1	Fun_4
	EJT48046.1	Fun_5
	XP_004344050.1	Pro_1
	XP_002957711.1	Pro_2
	KDO25841.1	Pro_3
	YP_002048931.1	Pro_4
	ETM55730.1	Pro_5
	XP_006349441.1	Pla_1
	XP_002299283.1	Pla_2
	XP_009616638.1	Pla_3
	XP_004308673.1	Pla_4

	XP_007034443.1	Pla_5
	WP_019265124.1	Arc_1
	BAM70565.1	Arc_2
	WP_012794906.1	Arc_3
	WP_015324088.1	Arc_4
	WP_007044926.1	Arc_5
	WP_038104505.1	Eub_1
	WP_013409982.1	Eub_2
	WP_008503908.1	Eub_3
	WP_020528805.1	Eub_4
	WP_028665191.1	Eub_5
	WP_018614696.1	Eub_6
	WP_019941946.1	Eub_7
	WP_014219091.1	Eub_8
	WP_019654887.1	Eub_9
	WP_019668624.1	Eub_10
maker-scaffold74_size115697-snap-gene-0.80	XP_003476522.2	Met_1
	XP_005074917.1	Met_2
	XP_008980014.1	Met_3
	XP_004419830.1	Met_4
	CCD51607.1	Fun_1
	KEZ42133.1	Fun_2
	KDR70855.1	Fun_3
	EXM13308.1	Fun_4
	ERZ98251.1	Fun_5
	KFM28438.1	Pro_1
	XP_009525286.1	Pro_2
	XP_002954015.1	Pro_3
	XP_005645567.1	Pro_4
	XP_006433979.1	Pla_1
	EPS68601.1	Pla_2
	XP_001770974.1	Pla_3
	XP_006665175.1	Pla_4
	WP_018031669.1	Arc_1
	WP_013898711.1	Arc_2
	AJB42102.1	Arc_3
	WP_006666899.1	Arc_4
	WP_013328338.1	Arc_5
	WP_034469967.1	Eub_1
	WP_024004493.1	Eub_2
	WP_034849348.1	Eub_3
	WP_030612374.1	Eub_4
	WP_036594895.1	Eub_5
	WP_020673966.1	Eub_6
	WP_010558786.1	Eub_7

	WP_037067205.1	Eub_8
	EUB98133.1	Eub_9
	WP_015102096.1	Eub_10
maker-scaffold741_size41061-snap-gene-0.36	ERG81996.1	Met_1
	XP_001897006.1	Met_2
	XP_003140874.1	Met_3
	EJW80422.1	Met_4
	ABR10533.1	Met_5
	XP_003031842.1	Fun_1
	XP_001836593.2	Fun_2
	KDQ25016.1	Fun_3
	XP_007844786.1	Fun_4
	CCA71030.1	Fun_5
	XP_007508888.1	Pro_1
	XP_002508499.1	Pro_2
	XP_005704929.1	Pro_3
	XP_009042022.1	Pro_4
	XP_005844860.1	Pro_5
	B9NJI2.1	Pla_1
	XP_010023871.1	Pla_2
	EYU18298.1	Pla_3
	XP_006354455.1	Pla_4
	EPS70702.1	Pla_5
	WP_023505025.1	Arc_1
	ERH04195.1	Arc_2
	EGQ40327.1	Arc_3
	WP_015020597.1	Arc_4
	WP_010979030.1	Arc_5
	WP_012433147.1	Eub_1
	WP_012005966.1	Eub_2
	GAK25757.1	Eub_3
	WP_020443882.1	Eub_4
	WP_012776286.1	Eub_5
	WP_010808883.1	Eub_6
	WP_020204195.1	Eub_7
	WP_008112803.1	Eub_8
	WP_028834723.1	Eub_9
	WP_006216888.1	Eub_10
maker-scaffold1707_size25220-snap-gene-0.20	XP_003731678.1	Met_1
	XP_008189390.1	Met_2
	ETN78939.1	Met_3
	CEF64082.1	Met_4
	KHJ89365.1	Met_5
	NP_504589.1	C_ele
	EIE85093.1	Fun_1

	EIE87794.1	Fun_2
	CEI86637.1	Fun_3
	EPB83410.1	Fun_4
	CDH56944.1	Fun_5
	XP_005703492.1	Pro_1
	XP_005645176.1	Pro_2
	KDD75725.1	Pro_3
	XP_002673099.1	Pro_4
	ETP23068.1	Pro_5
	XP_006656771.1	Pla_1
	XP_004964872.1	Pla_2
	XP_009362376.1	Pla_3
	XP_004155438.1	Pla_4
	KDP45639.1	Pla_5
	WP_012107096.1	Arc_1
	WP_012034393.1	Arc_2
	WP_011305459.1	Arc_3
	WP_004594272.1	Arc_4
	WP_007274653.1	Arc_5
	WP_031294976.1	Eub_1
	WP_024275156.1	Eub_2
	WP_003588285.1	Eub_3
	WP_028207412.1	Eub_4
	WP_006018784.1	Eub_5
	WP_024574813.1	Eub_6
	WP_027583392.1	Eub_7
	WP_014619199.1	Eub_8
	WP_036112488.1	Eub_9
	WP_035361153.1	Eub_10
maker-scaffold1303_size28699-snap-gene-0.21	XP_002806104.1	Met_1
	XP_002192539.2	Met_2
	XP_005419195.1	Met_3
	XP_006978840.1	Met_4
	XP_002593243.1	Met_5
	NP_610527.1	D_mel
	NP_509293.1	C_ele
	EKC37376.1	C_gig
	XP_006817962.1	S_kow
	XP_004938622.1	G_gal
	XP_001617488.1	N_vec
	KFH62725.1	Fun_1
	EPZ32472.1	Fun_2
	XP_007390932.1	Fun_3
	XP_006681728.1	Fun_4
	CDS03933.1	Fun_5

	YP_002049302.1	Pro_1
	XP_001617488.1	Pro_2
	XP_005710624.1	Pro_3
	ACX71633.1	Pro_4
	XP_002957277.1	Pro_5
	XP_002308127.1	Pla_1
	AHN05002.1	Pla_2
	XP_010106943.1	Pla_3
	XP_006286189.1	Pla_4
	XP_010533062.1	Pla_5
	WP_013295310.1	Arc_1
	WP_015732954.1	Arc_2
	WP_012067872.1	Arc_3
	WP_023991902.1	Arc_4
	WP_012955649.1	Arc_5
	WP_018616254.1	Eub_1
	WP_026763945.1	Eub_2
	WP_028787142.1	Eub_3
	WP_038106951.1	Eub_4
	WP_014216622.1	Eub_5
	AHF16791.1	Eub_6
	WP_012789332.1	Eub_7
	WP_039142427.1	Eub_8
	WP_018628351.1	Eub_9
	WP_026897004.1	Eub_10
maker-scaffold1970_size23533-snap-gene-0.24	EXL66283.1	Fun_1
	CCF36248.1	Fun_2
	XP_002652421.1	Fun_3
	XP_003190649.1	Fun_4
	XP_007915781.1	Fun_5
	ETI54099.1	Pro_1
	AIF84065.1	Arc_1
	WP_008894305.1	Arc_2
	WP_006107378.1	Arc_3
	WP_013328432.1	Arc_4
	AHG49912.1	Eub_1
	WP_012694949.1	Eub_2
	WP_026224969.1	Eub_3
	WP_035141167.1	Eub_4
	WP_012929377.1	Eub_5
	WP_028111420.1	Eub_6
	WP_028771385.1	Eub_7
	WP_032003234.1	Eub_8
	WP_013995789.1	Eub_9
	EWS60166.1	Eub_10

maker-scaffold714_size37228-augustus-gene-0.11	CDQ90276.1	Met_1
	XP_002411894.1	Met_2
	XP_005171639.1	Met_3
	XP_010901437.1	Met_4
	KFP89560.1	Met_5
	NP_001012711.1	G_gal
	XP_001635175.1	N_vec
	EPT06168.1	Fun_1
	EPB90531.1	Fun_2
	XP_007328597.1	Fun_3
	EJT50757.1	Fun_4
	KDQ27630.1	Fun_5
	XP_003064880.1	Pro_1
	XP_005833326.1	Pro_2
	XP_005646672.1	Pro_3
	XP_004339910.1	Pro_4
	XP_005705278.1	Pro_5
	XP_006409693.1	Pla_1
	XP_009112246.1	Pla_2
	XP_004242768.1	Pla_3
	XP_010467174.1	Pla_4
	XP_006297991.1	Pla_5
	XP_009601472.1	Pla_6
	NP_001169715.1	Pla_7
	EYU34983.1	Pla_8
	XP_002448043.1	Pla_9
	XP_010533132.1	Pla_10
	WP_004156226.1	Eub_1
	WP_008254071.1	Eub_2
	WP_035709327.1	Eub_3
	WP_007398271.1	Eub_4
	WP_028480955.1	Eub_5
maker-scaffold23270_size2748-snap-gene-0.5	XP_002118984.1	Met_1
	XP_003391334.1	Met_2
	ELT99311.1	Met_3
	XP_003699130.1	Met_4
	CDW58876.1	Met_5
	NP_649002.2	D_mel
	T31617	C_ele
	EKC17818.1	C_gig
	XP_006815639.1	S_kow
	XP_419578.3	G_gal
	XP_001618124.1	N_vec
	KGQ13756.1	Fun_1
	KGQ13060.1	Fun_2

	KGQ11395.1	Fun_3
	XP_006683391.1	Fun_4
	KGQ11088.1	Fun_5
	NP_038429.1	Pro_1
	YP_001019096.1	Pro_2
	YP_009104843.1	Pro_3
	YP_009105303.1	Pro_4
	YP_009057862.1	Pro_5
	Q9G4F5.1	Pla_1
	AET49991.1	Pla_2
	AET49983.1	Pla_3
	AET49973.1	Pla_4
	AET50438.1	Pla_5
	WP_014734334.1	Arc_1
	AIU70275.1	Arc_2
	AIF69503.1	Arc_3
	WP_013303172.1	Arc_4
	WP_020863289.1	Arc_5
	WP_014198142.1	Eub_1
	WP_027135204.1	Eub_2
	WP_011940683.1	Eub_3
	WP_036811241.1	Eub_4
	BAO84414.1	Eub_5
	WP_011478976.1	Eub_6
	WP_006977611.1	Eub_7
	WP_002718400.1	Eub_8
	WP_014743767.1	Eub_9
	WP_014253865.1	Eub_10
maker-scaffold6300_size12324-augustus-gene-0.6	XP_002604501.1	Met_1
	XP_002159609.1	Met_2
	XP_005095151.1	Met_3
	XP_002164963.2	Met_4
	XP_009057420.1	Met_5
	EKC23227.1	C_gig
	XP_002737725.1	S_kow
	XP_001628381.1	N_vec
	XP_007794286.1	Fun_1
	XP_007275825.1	Fun_2
	KFY77670.1	Fun_3
	XP_007306115.1	Fun_4
	XP_001547379.1	Fun_5
	ETO07630.1	Pro_1
	XP_002953862.1	Pro_2
	XP_003287902.1	Pro_3
	KFM27798.1	Pro_4

	XP_005837090.1	Pro_5
	XP_001772057.1	Pla_1
	XP_008227861.1	Pla_2
	XP_006848003.1	Pla_3
	XP_002526188.1	Pla_4
	XP_004152260.1	Pla_5
	WP_012966226.1	Arc_1
	WP_014289847.1	Arc_2
	WP_021789437.1	Arc_3
	WP_011022499.1	Arc_4
	WP_006184198.1	Arc_5
	WP_004462863.1	Eub_1
	WP_010742748.1	Eub_2
	WP_028445519.1	Eub_3
	WP_011669200.1	Eub_4
	WP_011163473.1	Eub_5
	GAF38603.1	Eub_6
	WP_038450915.1	Eub_7
	WP_021270991.1	Eub_8
	WP_002771241.1	Eub_9
	WP_011333596.1	Eub_10
augustus_masked-scaffold12066_size7863-processed-gene-0.3	XP_002118959.1	Met_1
	ERL83435.1	Met_2
	ERL83750.1	Met_3
	XP_004703334.1	Met_4
	XP_008265796.1	Met_5
	NP_651281.1	D_mel
	NP_500396.2	C_ele
	EKC28295.1	C_gig
	XP_002741459.1	S_kow
	NP_001026322.1	G_gal
	XP_001629231.1	N_vec
	XP_001833294.1	Fun_1
	CCG82054.1	Fun_2
	XP_002791658.1	Fun_3
	CDS05260.1	Fun_4
	EPB84866.1	Fun_5
	XP_004345355.1	Pro_1
	XP_005849584.1	Pro_2
	XP_005717384.1	Pro_3
	KDD74654.1	Pro_4
	XP_001697738.1	Pro_5
	EDQ48391.1	Pla_1
	XP_008438188.1	Pla_2
	XP_009628694.1	Pla_3

	XP_002963527.1	Pla_4
	ABK93110.1	Pla_5
	WP_010612452.1	Arc_1
	WP_004076747.1	Arc_2
	KHO51084.1	Arc_3
	WP_014867498.1	Arc_4
	WP_012035049.1	Arc_5
	WP_020084145.1	Eub_1
	WP_036261259.1	Eub_2
	BAQ17180.1	Eub_3
	WP_038035648.1	Eub_4
	WP_003608822.1	Eub_5
	WP_017930323.1	Eub_6
	WP_029032151.1	Eub_7
	WP_012591085.1	Eub_8
	WP_016919432.1	Eub_9
	WP_026191148.1	Eub_10
maker-scaffold668_size38133-augustus-gene-0.18	CCT75179.1	Fun_1
	XP_007915781.1	Fun_2
	CEG03788.1	Fun_3
	ENH86162.1	Fun_4
	XP_002652421.1	Fun_5
	AIF84065.1	Arc_1
	WP_013328432.1	Arc_2
	WP_008321774.1	Arc_3
	WP_014406894.1	Arc_4
	WP_005554895.1	Arc_5
	WP_012929377.1	Eub_1
	WP_019615394.1	Eub_2
	WP_022841236.1	Eub_3
	WP_026554862.1	Eub_4
	WP_026224969.1	Eub_5
	WP_028764304.1	Eub_6
	WP_032552964.1	Eub_7
	WP_033092365.1	Eub_8
	WP_012155435.1	Eub_9
	KDN27447.1	Eub_10
snap_masked-scaffold5501_size13528-processed-gene-0.4	XP_002115370.1	Met_1
	XP_784834.3	Met_2
	XP_003385092.1	Met_3
	XP_009859233.1	Met_4
	XP_002595879.1	Met_5
	ABY20525.1	D_mel
	NP_001122771.1	C_ele
	EKC25349.1	C_gig

	XP_002735842.1	S_kow
	XP_001639606.1	N_vec
	KDQ21556.1	Fun_1
	XP_007766348.1	Fun_2
	XP_006689693.1	Fun_3
	XP_500422.1	Fun_4
	CDO93299.1	Fun_5
	GAM25728.1	Pro_1
	EFA79031.1	Pro_2
	XP_641412.1	Pro_3
	XP_004350946.1	Pro_4
	AIG56123.1	Pro_5
	XP_006361557.1	Pla_1
	XP_009779158.1	Pla_2
	EYU25916.1	Pla_3
	XP_010248964.1	Pla_4
	XP_002315613.1	Pla_5
	WP_014866607.1	Arc_1
	WP_014866613.1	Arc_2
	WP_009366644.1	Arc_3
	WP_038008578.1	Eub_1
	WP_018612052.1	Eub_2
	WP_018630286.1	Eub_3
	WP_014222462.1	Eub_4
	AHF15920.1	Eub_5
	WP_018616504.1	Eub_6
	WP_026768040.1	Eub_7
	WP_008511674.1	Eub_8
	WP_027303192.1	Eub_9
	WP_015333223.1	Eub_10
maker-scaffold80_size93979-augustus-gene-0.47	XP_007353035.1	Fun_1
	XP_007341488.1	Fun_2
	EPT02934.1	Fun_3
	ESA00332.1	Fun_4
	EPT02936.1	Fun_5
	CCX29845.1	Fun_6
	EIT75643.1	Fun_7
	EWC44163.1	Fun_8
	CCX12997.1	Fun_9
	WP_024543877.1	Eub_1
	WP_036538167.1	Eub_2
	WP_022421141.1	Eub_3
maker-scaffold81_size93674-augustus-gene-0.43	XP_001635316.1	Met_1
	XP_001625497.1	N_vec
	CCA67478.1	Fun_1

	XP_011113843.1	Fun_2
	EYE90242.1	Fun_3
	KFH63080.1	Fun_4
	XP_011119164.1	Fun_5
	KFH62165.1	Fun_6
	XP_001396119.1	Fun_7
	KDQ07441.1	Fun_8
	XP_007308597.1	Fun_9
	XP_007784710.1	Fun_10
	XP_008619938.1	Pro_1
	XP_009846803.1	Pro_2
	XP_008612269.1	Pro_3
	KDO25464.1	Pro_4
	XP_008864995.1	Pro_5
	XP_001783997.1	Pla_1
	WP_020477589.1	Eub_1
	WP_012234898.1	Eub_2
	WP_031532596.1	Eub_3
	WP_034340452.1	Eub_4
	WP_021219852.1	Eub_5
augustus_masked-scaffold18573_size4385-processed-gene-0.0	GAA58059.1	Met_1
	ELU00505.1	Met_2
	CDW58870.1	Met_3
	KGQ13804.1	Fun_1
	EQB46837.1	Fun_2
	WP_018998016.1	Eub_1
	WP_035550939.1	Eub_2
	WP_027837242.1	Eub_3
	WP_018148267.1	Eub_4
	WP_022694509.1	Eub_5
	WP_023430577.1	Eub_6
	WP_025315741.1	Eub_7
	WP_024515802.1	Eub_8
	ESQ80264.1	Eub_9
	WP_016848080.1	Eub_10
snap_masked-scaffold126_size77140-processed-gene-0.47	CEF69733.1	Met_1
	XP_010873377.1	Met_2
	EYB85258.1	Met_3
	CDJ89535.1	Met_4
	XP_002126015.1	Met_5
	NP_728287.1	D_mel
	NP_502129.1	C_ele
	CAJ28912.1	C_gig
	XP_002735158.1	S_kow
	XP_001625748.1	G_gal

	XP_425746.3	N_vec
	KGQ03886.1	Fun_1
	NP_593344.2	Fun_2
	EIE92264.1	Fun_3
	XP_003850503.1	Fun_4
	XP_006960118.1	Fun_5
	XP_001302152.1	Pro_1
	XP_002953022.1	Pro_2
	XP_004338851.1	Pro_3
	XP_003285028.1	Pro_4
	ETM39756.1	Pro_5
	O24357.1	Pla_1
	BAK22407.1	Pla_2
	AAD11426.1	Pla_3
	XP_010689260.1	Pla_4
	XP_009601968.1	Pla_5
	KHO54121.1	Arc_1
	EGQ40083.1	Arc_2
	WP_012911419.1	Eub_1
	WP_015941895.1	Eub_2
	WP_012256405.1	Eub_3
	WP_008680665.1	Eub_4
	CAJ71041.1	Eub_5
	WP_002652772.1	Eub_6
	WP_007906484.1	Eub_7
	WP_012120368.1	Eub_8
	WP_015167768.1	Eub_9
	WP_006529261.1	Eub_10
snap_masked-scaffold1017_size31835-processed-gene-0.17	EFX83905.1	Met_1
	XP_003494251.1	Met_2
	XP_010559354.1	Met_3
	XP_004378960.1	Met_4
	XP_001617862.1	N_vec
	KGQ13982.1	Fun_1
	XP_003177581.1	Fun_2
	XP_007579619.1	Fun_3
	EME44586.1	Fun_4
	XP_003025685.1	Fun_5
	YP_002049168.1	Pro_1
	XP_004185929.1	Pro_2
	XP_002678007.1	Pro_3
	XP_004355659.1	Pro_4
	EFA83374.1	Pro_5
	WP_014435670.1	Eub_1
	WP_029631427.1	Eub_2

	WP_024789515.1	Eub_3
	WP_015902762.1	Eub_4
	WP_007474590.1	Eub_5
	WP_024787326.1	Eub_6
	WP_010048263.1	Eub_7
	WP_026441932.1	Eub_8
	WP_027069470.1	Eub_9
	WP_035354558.1	Eub_10
maker-scaffold6668_size11878-snap-gene-0.12	CCF36248.1	Fun_1
	EXL66283.1	Fun_2
	ENH75308.1	Fun_3
	EQB47608.1	Fun_4
	EKG12172.1	Fun_5
	XP_002904646.1	Pro_1
	WP_009745183.1	Eub_1
	WP_028111420.1	Eub_2
	WP_013995789.1	Eub_3
	WP_035141167.1	Eub_4
	AHG49912.1	Eub_5
	EWS60166.1	Eub_6
	WP_011659296.1	Eub_7
	WP_026224969.1	Eub_8
	WP_024954492.1	Eub_9
	GAL64436.1	Eub_10
snap_masked-scaffold815_size34909-processed-gene-0.7	ACD54692.1	Met_1
	AAH68857.1	Met_2
	XP_008940981.1	Met_3
	KFO12952.1	Met_4
	KFP27437.1	Met_5
	XP_002736730.1	S_kow
	NP_001025816.1	G_gal
	KEQ78741.1	Fun_1
	EWZ29179.1	Fun_2
	CEG03928.1	Fun_3
	CEI86337.1	Fun_4
	XP_002624644.1	Fun_5
	XP_002680137.1	Pro_1
	XP_005850260.1	Pro_2
	XP_007508961.1	Pro_3
	XP_003287526.1	Pro_4
	XP_001416652.1	Pro_5
	XP_009348165.1	Pla_1
	EPS64191.1	Pla_2
	XP_002536733.1	Pla_3
	XP_002870963.1	Pla_4

	WP_006077964.1	Arc_1
	WP_006882253.1	Arc_2
	WP_006091860.1	Arc_3
	WP_006056181.1	Arc_4
	WP_013446601.1	Arc_5
	WP_012166267.1	Eub_1
	KFE72029.1	Eub_2
	WP_032391925.1	Eub_3
	WP_034486151.1	Eub_4
	WP_026630463.1	Eub_5
	AHJ95389.1	Eub_6
	EMF30820.1	Eub_7
	WP_039545154.1	Eub_8
	WP_037286586.1	Eub_9
	KIA77623.1	Eub_10
maker-scaffold3236_size18566-augustus-gene-0.14	XP_001863560.1	Met_1
	ETN64199.1	Met_2
	XP_002053679.1	Met_3
	XP_009859733.1	Met_4
	XP_003402903.1	Met_5
	XP_006811586.1	S_kow
	AAS49609.1	G_gal
	XP_007418648.1	Fun_1
	XP_007338082.1	Fun_2
	XP_007265168.1	Fun_3
	XP_008088124.1	Fun_4
	KFA79683.1	Fun_5
	XP_002951308.1	Pro_1
	CCA23797.1	Pro_2
	CCA26038.1	Pro_3
	XP_005851515.1	Pro_4
	XP_005646097.1	Pro_5
	CCI48539.1	Pro_6
	XP_001701046.1	Pro_7
	CCI48547.1	Pro_8
	EZG51530.1	Pro_9
	XP_009517353.1	Pro_10
	XP_002971447.1	Pla_1
	XP_001764010.1	Pla_2
	XP_002971446.1	Pla_3
	XP_004151682.1	Pla_4
	XP_003630404.1	Pla_5
	WP_023395609.1	Arc_1
	WP_006671834.1	Arc_2
	WP_013880559.1	Arc_3

	WP_004054285.1	Arc_4
	AHF98631.1	Arc_5
	WP_017664906.1	Eub_1
	WP_015148708.1	Eub_2
	WP_039337939.1	Eub_3
	WP_031552011.1	Eub_4
	KHS42262.1	Eub_5
snap_masked-scaffold1455_size27142-processed-gene-0.8	XP_002115537.1	Met_1
	XP_010718094.1	Met_2
	XP_002603534.1	Met_3
	XP_006268481.1	Met_4
	XP_008937854.1	Met_5
	AAM29426.1	D_mel
	NP_499917.2	C_ele
	EKC32886.1	C_gig
	XP_006814856.1	S_kow
	NP_001026638.1	G_gal
	CEG64385.1	Fun_1
	EPB83705.1	Fun_2
	EIE81750.1	Fun_3
	KFH71279.1	Fun_4
	CDS06587.1	Fun_5
	KDO32230.1	Pro_1
	XP_008870509.1	Pro_2
	XP_003294319.1	Pro_3
	ETI49395.1	Pro_4
	XP_004333082.1	Pro_5
	ABR17689.1	Pla_1
	XP_006648248.1	Pla_2
	XP_010090722.1	Pla_3
	XP_004144903.1	Pla_4
	Q43768.1	Pla_5
	WP_016358804.1	Arc_1
	WP_013466491.1	Arc_2
	WP_013867239.1	Arc_3
	WP_011849820.1	Arc_4
	WP_012955740.1	Arc_5
	WP_018627148.1	Eub_1
	WP_038094260.1	Eub_2
	AHF16500.1	Eub_3
	WP_018617247.1	Eub_4
	WP_028787825.1	Eub_5
	WP_039138237.1	Eub_6
	WP_026772903.1	Eub_7
	WP_014221767.1	Eub_8

	WP_026764122.1	Eub_9
	WP_014682200.1	Eub_10
snap_masked-scaffold878_size33947-processed-gene-0.18	XP_002129957.1	Met_1
	XP_003698677.1	Met_2
	EHJ72678.1	Met_3
	XP_006860411.1	Met_4
	XP_008198812.1	Met_5
	CAR94311.1	D_mel
	NP_508282.2	C_ele
	EKC42344.1	C_gig
	NP_001171815.1	S_kow
	NP_990274.1	G_gal
	XP_001635838.1	N_vec
	KDE05724.1	Fun_1
	EMS20429.1	Fun_2
	EJT99034.1	Fun_3
	KDE09740.1	Fun_4
	KDE09741.1	Fun_5
	XP_004338019.1	Pro_1
	XP_005643770.1	Pro_2
	XP_005838806.1	Pro_3
	XP_001699466.1	Pro_4
	XP_005781104.1	Pro_5
	ACG33336.1	Pla_1
	XP_003579583.1	Pla_2
	XP_009392607.1	Pla_3
	XP_002311727.2	Pla_4
	XP_009616064.1	Pla_5
	WP_008604896.1	Arc_1
	KCZ70710.1	Arc_2
	WP_004572392.1	Arc_3
	WP_015589685.1	Arc_4
	WP_014513017.1	Arc_5
	WP_038200730.1	Eub_1
	WP_016848406.1	Eub_2
	WP_011442952.1	Eub_3
	WP_008738951.1	Eub_4
	WP_019573144.1	Eub_5
	WP_011952448.1	Eub_6
	WP_008905418.1	Eub_7
	WP_006575808.1	Eub_8
	WP_013395406.1	Eub_9
	WP_021003504.1	Eub_10
maker-scaffold6104_size12615-augustus-gene-0.9	XP_008313450.1	Met_1
	XP_008701134.1	Met_2

	KFP53927.1	Met_3
	XP_006127784.1	Met_4
	XP_006031586.1	Met_5
	NP_648343.1	D_mel
	NP_001022323.2	C_ele
	EKC43186.1	C_gig
	XP_002740401.1	S_kow
	XP_416454.1	G_gal
	XP_001634094.1	N_vec
	XP_002150272.1	Fun_1
	EYE94461.1	Fun_2
	GAD92769.1	Fun_3
	GAM38162.1	Fun_4
	XP_007783288.1	Fun_5
	EER41860.1	Fun_6
	XP_001820034.2	Fun_7
	XP_002483992.1	Fun_8
	XP_007699789.1	Fun_9
	XP_002837790.1	Fun_10
	XP_001016402.1	Pro_1
	CCA19296.1	Pro_2
	XP_008612667.1	Pro_3
	XP_002905635.1	Pro_4
	CCI11072.1	Pro_5
	EGQ39855.1	Arc_1
	WP_013295280.1	Arc_2
	WP_013267068.1	Arc_3
	WP_018033477.1	Arc_4
	WP_012310243.1	Arc_5
	WP_015353645.1	Eub_1
	WP_002694015.1	Eub_2
	WP_027885864.1	Eub_3
	WP_033094148.1	Eub_4
	AHI31487.1	Eub_5
snap_masked-scaffold2280_size22025-processed-gene-0.10	ACD54692.1	Met_1
	AAH68857.1	Met_2
	XP_008940981.1	Met_3
	KFP27437.1	Met_4
	KFO12952.1	Met_5
	XP_002736730.1	S_kow
	NP_001025816.1	G_gal
	KEQ78741.1	Fun_1
	EWZ29179.1	Fun_2
	CEG03928.1	Fun_3
	CEI86337.1	Fun_4

	XP_002624644.1	Fun_5
	XP_002680137.1	Pro_1
	XP_005850260.1	Pro_2
	XP_003287526.1	Pro_3
	EFA85925.1	Pro_4
	XP_007508961.1	Pro_5
	XP_009348165.1	Pla_1
	EPS64191.1	Pla_2
	XP_010673662.1	Pla_3
	XP_007218282.1	Pla_4
	XP_002536733.1	Pla_5
	WP_006077964.1	Arc_1
	WP_006882253.1	Arc_2
	WP_006091860.1	Arc_3
	WP_004051141.1	Arc_4
	WP_012942676.1	Arc_5
	WP_012166267.1	Eub_1
	KFE72029.1	Eub_2
	WP_032391925.1	Eub_3
	WP_034486151.1	Eub_4
	WP_026630463.1	Eub_5
	AHJ95389.1	Eub_6
	EMF30820.1	Eub_7
	WP_037286586.1	Eub_8
	WP_039545154.1	Eub_9
	WP_006341105.1	Eub_10
maker-scaffold505_size42588-augustus-gene-0.26	CDW58869.1	Met_1
	XP_002412211.1	Met_2
	XP_002429700.1	Met_3
	XP_008557991.1	Met_4
	XP_001600500.3	Met_5
	NP_001097800.1	D_mel
	NP_508784.1	C_ele
	EKC32808.1	C_gig
	XP_006819255.1	S_kow
	NP_989795.1	G_gal
	XP_001633856.1	N_vec
	XP_006675041.1	Fun_1
	KFH72372.1	Fun_2
	XP_003047675.1	Fun_3
	EGU79127.1	Fun_4
	CEG84518.1	Fun_5
	XP_001825252.1	Fun_6
	XP_002585229.1	Fun_7
	KEY64896.1	Fun_8

	KGQ02839.1	Fun_9
	XP_006969358.1	Fun_10
	XP_008604566.1	Pro_1
	CCI10344.1	Pro_2
	XP_009520062.1	Pro_3
	XP_008900549.1	Pro_4
	KDO31096.1	Pro_5
	NP_001130547.1	Pla_1
	XP_006414895.1	Pla_2
	XP_008441797.1	Pla_3
	AEZ06603.1	Pla_4
	NP_176658.1	Pla_5
	WP_015018905.1	Arc_1
	AIC14428.1	Arc_2
	AIF85373.1	Arc_3
	AIG98750.1	Arc_4
	WP_013295862.1	Arc_5
	WP_036760862.1	Eub_1
	WP_013787785.1	Eub_2
	WP_039746122.1	Eub_3
	WP_014759056.1	Eub_4
	WP_034122822.1	Eub_5
augustus_masked-scaffold9576_size9323-processed-gene-0.1	XP_006679675.1	Fun_1
	KFH70558.1	Fun_2
	KGQ13027.1	Fun_3
	XP_006683186.1	Fun_4
	GAA99771.1	Fun_5
	XP_009534325.1	Pro_1
	XP_644484.1	Pro_2
	ETK91235.1	Pro_3
	XP_008605341.1	Pro_4
	XP_008876749.1	Pro_5
	XP_001760648.1	Pla_1
	EMS63829.1	Pla_2
	WP_006078928.1	Arc_1
	WP_023394045.1	Arc_2
	KDE60150.1	Arc_3
	WP_021055597.1	Arc_4
	WP_012942239.1	Arc_5
	WP_014704038.1	Eub_1
	WP_020593968.1	Eub_2
	WP_037256093.1	Eub_3
	KGM11498.1	Eub_4
	WP_019645166.1	Eub_5
maker-scaffold1407_size27578-augustus-gene-0.17	XP_001601958.2	Met_1

	XP_009017213.1	Met_2
	NP_001087172.1	Met_3
	XP_011064524.1	Met_4
	EFN63332.1	Met_5
	4INE_A	C_ele
	EKC35398.1	C_gig
	XP_002739709.1	S_kow
	XP_001232694.1	G_gal
	XP_001634000.1	N_vec
	XP_007596830.1	Fun_1
	XP_002569186.1	Fun_2
	EWG54069.1	Fun_3
	XP_001593795.1	Fun_4
	XP_459613.2	Fun_5
	XP_001580573.1	Pro_1
	XP_005713374.1	Pro_2
	XP_005773499.1	Pro_3
	EWM24131.1	Pro_4
	CBN78409.1	Pro_5
	XP_002968407.1	Pla_1
	XP_009348175.1	Pla_2
	XP_003579980.1	Pla_3
	AIU50555.1	Pla_4
	EMT16365.1	Pla_5
	WP_012186229.1	Arc_1
	WP_012617787.1	Arc_2
	WP_013775078.1	Arc_3
	WP_007983554.1	Arc_4
	WP_008296858.1	Arc_5
	WP_019215882.1	Eub_1
	WP_010298206.1	Eub_2
	WP_008347973.1	Eub_3
	WP_031498896.1	Eub_4
	ABM63527.1	Eub_5
	WP_022585625.1	Eub_6
	WP_016641614.1	Eub_7
	WP_029057614.1	Eub_8
	BAP56505.1	Eub_9
augustus_masked-scaffold9669_size9263-processed-gene-0.3	ELT97960.1	Met_1
	KDR09741.1	Met_2
	KFM68371.1	Met_3
	KFB43555.1	Met_4
	XP_002118651.1	Met_5
	AAN71524.1	D_mel
	NP_001021098.1	C_ele

	EKC26712.1	C_gig
	XP_002731411.1	S_kow
	XP_418755.2	G_gal
	XP_001618992.1	N_vec
	2CDH_A	Fun_1
	KGQ11405.1	Fun_2
	CDS08812.1	Fun_3
	CDH56624.1	Fun_4
	EPB82703.1	Fun_5
	XP_005823341.1	Pro_1
	XP_002295282.1	Pro_2
	XP_002184832.1	Pro_3
	XP_005757743.1	Pro_4
	XP_009035098.1	Pro_5
	XP_004154138.1	Pla_1
	EPS57968.1	Pla_2
	XP_009609922.1	Pla_3
	XP_010247079.1	Pla_4
	XP_010099482.1	Pla_5
	WP_004557741.1	Arc_1
	KHO46614.1	Arc_2
	KHO44920.1	Arc_3
	ACD50086.1	Arc_4
	ABZ10239.1	Arc_5
	WP_019402450.1	Eub_1
	WP_026380570.1	Eub_2
	WP_038035251.1	Eub_3
	WP_029006643.1	Eub_4
	WP_013650826.1	Eub_5
	WP_037019720.1	Eub_6
	WP_026363019.1	Eub_7
	WP_002717667.1	Eub_7
	WP_013420191.1	Eub_8
	WP_026599453.1	Eub_9
	WP_037234575.1	Eub_10
snap_masked-scaffold9056_size9691-processed-gene-0.3	XP_006531193.1	Met_1
	XP_008985607.1	Met_2
	XP_003148136.1	Met_3
	XP_007488547.1	Met_4
	XP_003915030.1	Met_5
	NP_648188.2	D_mel
	NP_496557.1	C_ele
	EKC21635.1	C_gig
	XP_006812871.1	S_kow
	XP_001626743.1	N_vec

	EJT51597.1	Fun_1
	EPZ35788.1	Fun_2
	XP_006460072.1	Fun_3
	CEG63676.1	Fun_4
	XP_003851660.1	Fun_5
	XP_002260871.1	Pro_1
	XP_005702511.1	Pro_2
	XP_005535085.1	Pro_3
	XP_002142822.1	Pro_4
	XP_009690068.1	Pro_5
	EEE69722.1	Pla_1
	XP_010090007.1	Pla_2
	NP_001063201.2	Pla_3
	XP_007008769.1	Pla_4
	KHG22370.1	Pla_5
	WP_019176442.1	Arc_1
	WP_020448503.1	Arc_2
	AIF01059.1	Arc_3
	AIF20386.1	Arc_4
	WP_013304288.1	Arc_5
	WP_014559534.1	Eub_1
	WP_012475834.1	Eub_2
	WP_012909357.1	Eub_3
	WP_024124480.1	Eub_4
	WP_008274272.1	Eub_5
	WP_014787305.1	Eub_6
	WP_035404323.1	Eub_7
	WP_035359167.1	Eub_8
	WP_012509487.1	Eub_9
	WP_026386373.1	Eub_10
snap_masked-scaffold3_size1208507-processed-gene-1.67	KGQ11486.1	Fun_1
	XP_003342548.1	Fun_2
	WP_006301239.1	Eub_1
	WP_011689073.1	Eub_2
	WP_021169337.1	Eub_3
	WP_038673988.1	Eub_4
	WP_009438161.1	Eub_5
	WP_029890012.1	Eub_6
	WP_007289605.1	Eub_7
	EFC91998.1	Eub_8
	WP_009851450.1	Eub_9
	WP_033297033.1	Eub_10
snap_masked-scaffold1340_size28252-processed-gene-0.28	ACD54626.1	Met_1
	ACD54645.1	Met_2
	XP_001893058.1	Met_3

	CDQ03277.1	Met_4
	EJD74412.1	Met_5
	NP_730974.1	D_mel
	NP_497031.1	C_ele
	EKC38462.1	C_gig
	XP_002734132.1	S_kow
	XP_420669.1	G_gal
	XP_001636143.1	N_vec
	KIH93225.1	Fun_1
	XP_001226343.1	Fun_2
	KFY39086.1	Fun_3
	CDK25302.1	Fun_4
	XP_007791962.1	Fun_5
	XP_004343968.1	Pro_1
	CBN74948.1	Pro_2
	GAM16829.1	Pro_3
	XP_001700799.1	Pro_4
	XP_008619723.1	Pro_5
	NP_001291332.1	Pla_1
	XP_010674766.1	Pla_2
	EYU34848.1	Pla_3
	XP_009769381.1	Pla_4
	XP_002517192.1	Pla_5
	WP_006077499.1	Arc_1
	WP_007997796.1	Arc_2
	WP_006065817.1	Arc_3
	WP_007551724.1	Arc_4
	WP_021058435.1	Arc_5
	WP_007910273.1	Eub_1
	WP_007915149.1	Eub_2
	GAM09081.1	Eub_3
	WP_013795904.1	Eub_4
	WP_013659948.1	Eub_5
	WP_015830888.1	Eub_6
	WP_027075673.1	Eub_7
	WP_015023955.1	Eub_8
	WP_014219737.1	Eub_9
	WP_007092866.1	Eub_10
snap_masked-scaffold962_size32525-processed-gene-0.12	XP_007833246.1	Fun_1
	XP_007761072.1	Fun_2
	EGE08625.1	Fun_3
	KEF52212.1	Fun_4
	XP_003013217.1	Fun_5
	XP_001580573.1	Pro_1
	XP_007833246.1	Pro_2

	XP_004991255.1	Pro_3
	XP_007761072.1	Pro_4
	EGE08625.1	Pro_5
	XP_004137342.1	Pla_1
	AFW56731.1	Pla_2
	XP_003598143.1	Pla_3
	EMT02962.1	Pla_4
	WP_022532643.1	Arc_1
	WP_015504788.1	Arc_2
	WP_006628133.1	Arc_3
	WP_008386083.1	Arc_4
	WP_011499002.1	Arc_5
	CEG55859.1	Eub_1
	WP_016211643.1	Eub_2
	ABK51300.1	Eub_3
	WP_031415136.1	Eub_4
	WP_030668919.1	Eub_5
	CEG59739.1	Eub_6
	WP_031498896.1	Eub_7
	BAP56505.1	Eub_8
	WP_011134776.1	Eub_9
	WP_029057614.1	Eub_10
	WP_020554441.1	Eub_11
	WP_010298206.1	Eub_12
	WP_019350309.1	Eub_13
	WP_020519747.1	Eub_14
	CDR33214.1	Eub_15
	WP_008347973.1	Eub_16
	WP_024807775.1	Eub_17
	WP_014397962.1	Eub_18
	WP_019903222.1	Eub_19
	AIG81138.1	Eub_20
augustus_masked-scaffold1821_size45607-processed-gene-0.1	XP_003728116.1	Met_1
	ELT95020.1	Met_2
	XP_011059306.1	Met_3
	XP_394075.2	Met_4
	EFN66599.1	Met_5
	NP_650955.1	D_mel
	NP_509306.2	C_ele
	EKC34455.1	C_gig
	XP_002740933.1	S_kow
	NP_001012912.1	G_gal
	XP_001634142.1	N_vec
	KDN68924.1	Fun_1
	XP_002472258.1	Fun_2

	XP_008024997.1	Fun_3
	CDO73769.1	Fun_4
	EMD40491.1	Fun_5
	EHK40673.1	Fun_6
	XP_007365091.1	Fun_7
	XP_009851670.1	Fun_8
	XP_007675050.1	Fun_9
	XP_003351183.1	Fun_10
	XP_004335502.1	Pro_1
	XP_001701010.1	Pro_2
	XP_003294847.1	Pro_3
	XP_005838680.1	Pro_4
	ETP33338.1	Pro_5
	XP_002522468.1	Pla_1
	XP_008389453.1	Pla_2
	XP_006827316.1	Pla_3
	XP_010108696.1	Pla_4
	XP_009356318.1	Pla_5
	EET89913.1	Arc_1
	AIF16351.1	Arc_2
	WP_028833180.1	Eub_1
	AHF17277.1	Eub_2
	WP_036351736.1	Eub_3
	EIM93886.1	Eub_4
	WP_036353620.1	Eub_5
maker-scaffold962_size32525-snap-gene-0.37	XP_002619069.1	Fun_1
	XP_003851796.1	Fun_2
	XP_007375689.1	Fun_3
	CDK29424.1	Fun_4
	XP_003869357.1	Fun_5
	XP_004334482.1	Pro_1
	WP_011163281.1	Eub_1
	EQC48417.1	Eub_2
	WP_013965635.1	Eub_3
	WP_025223565.1	Eub_4
	WP_035939087.1	Eub_5
	WP_009386051.1	Eub_6
	WP_020183501.1	Eub_7
	WP_010508354.1	Eub_8
	WP_035152282.1	Eub_9
	WP_035120695.1	Eub_10
snap_masked-scaffold4287_size15745-processed-gene-0.5	no hits	
snap_masked-scaffold4718_size14934-processed-gene-0.15	CDW59746.1	Met_1
	XP_002119052.1	Met_2
	3DKN_A	Met_3

	XP_009681318.1	Met_4
	XP_009881313.1	Met_5
	NP_609034.1	D_mel
	NP_001255838.1	C_ele
	EKC26790.1	C_gig
	XP_006816377.1	S_kow
	XP_424024.4	G_gal
	XP_001628073.1	N_vec
	KGQ02389.1	Fun_1
	EXX53139.1	Fun_2
	CDO68422.1	Fun_3
	EJT48324.1	Fun_4
	ESW99430.1	Fun_5
	YP_009027579.1	Pro_1
	NP_050786.1	Pro_2
	YP_001293597.1	Pro_3
	P38397.1	Pro_4
	NP_053907.1	Pro_5
	XP_009350065.1	Pla_1
	CDP02922.1	Pla_2
	KDP34242.1	Pla_3
	XP_007138413.1	Pla_4
	XP_010048699.1	Pla_5
	WP_012310215.1	Arc_1
	WP_012965661.1	Arc_2
	WP_011012942.1	Arc_3
	WP_011832482.1	Arc_4
	WP_040681599.1	Arc_5
	WP_014438266.1	Eub_1
	WP_015244086.1	Eub_2
	WP_013628404.1	Eub_3
	CAJ73737.1	Eub_4
	WP_007221923.1	Eub_5
	WP_013564967.1	Eub_6
	WP_002649732.1	Eub_7
	WP_002655454.1	Eub_8
	WP_010587091.1	Eub_9
	WP_020476317.1	Eub_10
snap_masked-scaffold10640_size8688-processed-gene-0.5	ELU11586.1	Met_1
	XP_002609272.1	Met_2
	XP_007766017.1	Fun_1
	XP_008032395.1	Fun_2
	XP_011102440.1	Fun_3
	XP_001396961.1	Fun_4
	XP_007838045.1	Fun_5

	XP_007513564.1	Pro_1
	XP_005784428.1	Pro_2
	XP_009035520.1	Pro_3
	XP_007508281.1	Pro_4
	CDY68131.1	Pla_1
	CDP02924.1	Pla_2
	XP_006657848.1	Pla_3
	XP_009387336.1	Pla_4
	XP_007014012.1	Pla_5
	WP_020863576.1	Arc_1
	WP_010866657.1	Arc_2
	WP_013481327.1	Arc_3
	AIC15656.1	Arc_4
	WP_022541922.1	Arc_5
	BAL53572.1	Eub_1
	WP_014559711.1	Eub_2
	WP_015896494.1	Eub_3
	WP_014203411.1	Eub_4
	WP_001026493.1	Eub_5
	WP_013764674.1	Eub_6
	WP_014781258.1	Eub_7
	WP_015845731.1	Eub_8
	BAL58415.1	Eub_9
	WP_027421227.1	Eub_10
maker-scaffold10066_size9005-snap-gene-0.15	XP_003087098.1	Met_1
	YP_002048979.1	Pro_1
	XP_002536861.1	Pla_1
	WP_011830907.1	Eub_1
	WP_019559810.1	Eub_2
	WP_029000600.1	Eub_3
	WP_035035329.1	Eub_4
	WP_009552958.1	Eub_5
	WP_022981865.1	Eub_6
	WP_012348488.1	Eub_7
	WP_019375169.1	Eub_8
	WP_037485812.1	Eub_9
	WP_015012782.1	Eub_10
maker-scaffold642_size38736-augustus-gene-0.18	XP_001943310.1	Met_1
	EHJ63886.1	Met_2
	XP_007345748.1	Fun_1
	XP_003031610.1	Fun_2
	XP_007347991.1	Fun_3
	KDD75720.1	Pro_1
	EJY78055.1	Pro_2
	CDW90346.1	Pro_3

	XP_009530917.1	Pro_4
	XP_001579287.1	Pro_5
	XP_004151369.1	Pla_1
	XP_002537984.1	Pla_2
	XP_001786589.1	Pla_3
	XP_006663972.1	Pla_4
	XP_008660435.1	Pla_5
	AHF99242.1	Arc_1
	WP_015789150.1	Arc_2
	WP_006883391.1	Arc_3
	WP_004971927.1	Arc_4
	WP_009367567.1	Arc_5
	WP_039451872.1	Eub_1
	WP_013073700.1	Eub_2
	WP_036725502.1	Eub_3
	WP_020531984.1	Eub_4
	WP_035684664.1	Eub_5
	WP_015027914.1	Eub_6
	WP_015311875.1	Eub_7
	WP_036676929.1	Eub_8
	WP_027125087.1	Eub_9
	WP_034862220.1	Eub_10
maker-scaffold6505_size12078-augustus-gene-0.8	XP_009052269.1	Met_1
	XP_009052268.1	Met_2
	XP_005111403.1	Met_3
	EHJ77786.1	Met_4
	XP_001655874.1	Met_5
	ADG57801.1	D_mel
	NP_510594.1	C_ele
	EKC41751.1	C_gig
	XP_002740991.1	S_kow
	NP_001026459.1	G_gal
	XP_001636998.1	N_vec
	KDQ07936.1	Fun_1
	KIJ63201.1	Fun_2
	EPE10440.1	Fun_3
	XP_001222477.1	Fun_4
	CCO36641.1	Fun_5
	KFA60784.1	Fun_6
	XP_001823632.1	Fun_7
	CEL55975.1	Fun_8
	XP_002379056.1	Fun_9
	KIK55609.1	Fun_10
	XP_005774063.1	Pro_1
	EFA85653.1	Pro_2

	XP_002672231.1	Pro_3
	XP_002946174.1	Pro_4
	GAM22201.1	Pro_5
	XP_001753121.1	Pla_1
	XP_001774865.1	Pla_2
	XP_002986513.1	Pla_3
	NP_001142298.1	Pla_4
	XP_002994600.1	Pla_5
	WP_013898607.1	Arc_1
	AHG02284.1	Arc_2
	WP_006089530.1	Arc_3
	WP_008422764.1	Arc_4
	WP_008012272.1	Arc_5
	WP_028378880.1	Eub_1
	WP_027221611.1	Eub_2
	WP_019232553.1	Eub_3
	KFJ64412.1	Eub_4
	WP_038216498.1	Eub_5
snap_masked-scaffold7608_size10871-processed-gene-0.11	CDW58870.1	Met_1
	ELT91826.1	Met_2
	XP_003693465.1	Met_3
	GAA58058.1	Met_4
	XP_001620267.1	N_vec
	YP_002049422.1	Pro_1
	AIF15384.1	Arc_1
	WP_014433065.1	Eub_1
	BAL58009.1	Eub_2
	WP_012874254.1	Eub_3
	WP_025748671.1	Eub_4
	WP_003869947.1	Eub_5
	WP_003867375.1	Eub_6
	WP_017815717.1	Eub_7
	WP_008476413.1	Eub_8
	WP_039043167.1	Eub_9
	WP_021619697.1	Eub_10
snap_masked-scaffold10_size447749-processed-gene-1.21	XP_010081449.1	Met_1
	KFQ87123.1	Met_2
	KFV62490.1	Met_3
	XP_009908243.1	Met_4
	XP_008049841.1	Met_5
	NP_730250.1	D_mel
	NP_491165.2	C_ele
	EKC25512.1	C_gig
	XP_002741203.1	S_kow
	XP_004939779.1	G_gal

	XP_001632616.1	N_vec
	EIE80123.1	Fun_1
	EPB90189.1	Fun_2
	KFH68520.1	Fun_3
	KIJ38474.1	Fun_4
	XP_003038563.1	Fun_5
	XP_004340807.1	Pro_1
	XP_005822221.1	Pro_2
	XP_002505472.1	Pro_3
	XP_003082962.1	Pro_4
	XP_003292084.1	Pro_5
	XP_010931245.1	Pla_1
	XP_008777200.1	Pla_2
	EPS71434.1	Pla_3
	EMT04659.1	Pla_4
	EEC79350.1	Pla_5
	WP_018035257.1	Arc_1
	AIF20054.1	Arc_2
	WP_018035131.1	Arc_3
	WP_011019246.1	Arc_4
	WP_015491691.1	Arc_5
	WP_037360570.1	Eub_1
	WP_037369803.1	Eub_2
	WP_037352617.1	Eub_3
	WP_033411345.1	Eub_4
	WP_035465307.1	Eub_5
	WP_039137089.1	Eub_6
	WP_014221908.1	Eub_7
	WP_028787176.1	Eub_8
	AHF16047.1	Eub_9
	WP_026902710.1	Eub_10
snap_masked-scaffold10028_size9034-processed-gene-0.14	XP_005774972.1	Pro_1
	ABI13173.1	Pro_2
	XP_004334991.1	Pro_3
	XP_008611830.1	Pro_4
	XP_008228548.1	Pla_1
	ABK35747.1	Pla_2
	XP_007217721.1	Pla_3
	XP_008228546.1	Pla_4
	XP_008228549.1	Pla_5
	AJF62674.1	Arc_1
	WP_015283288.1	Arc_2
	WP_015019187.1	Arc_3
	WP_013467005.1	Arc_4
	AIY90136.1	Arc_5

	WP_038663484.1	Eub_1
	WP_037534949.1	Eub_2
	WP_017977922.1	Eub_3
	GAM01630.1	Eub_4
	WP_007403352.1	Eub_5
	WP_039096965.1	Eub_6
	WP_019371167.1	Eub_7
	WP_023837964.1	Eub_8
	WP_033926094.1	Eub_9
	WP_026090772.1	Eub_10
snap_masked-scaffold10032_size9031-processed-gene-0.5	XP_006572683.1	Met_1
	XP_003384413.1	Met_2
	XP_008177878.1	Met_3
	ELU16414.1	Met_4
	XP_006129701.1	Met_5
	NP_788477.1	D_mel
	EKC20330.1	C_gig
	XP_006813535.1	S_kow
	XP_001640548.1	N_vec
	XP_002616817.1	Fun_1
	XP_008038010.1	Fun_2
	CCG82215.1	Fun_3
	CDH53741.1	Fun_4
	CDS02868.1	Fun_5
	XP_004258806.1	Pro_1
	XP_001429450.1	Pro_2
	XP_637469.1	Pro_3
	XP_001432773.1	Pro_4
	CCI48117.1	Pro_5
	XP_001776978.1	Pla_1
	XP_010264162.1	Pla_2
	XP_004506491.1	Pla_3
	XP_002319326.2	Pla_4
	XP_010518148.1	Pla_5
	WP_011009538.1	Arc_1
	WP_011900532.1	Arc_2
	WP_021062030.1	Arc_3
	WP_009376705.1	Arc_4
	WP_020445114.1	Arc_5
	WP_008504811.1	Eub_1
	WP_014166640.1	Eub_2
	WP_019988798.1	Eub_3
	WP_021191018.1	Eub_4
	WP_011585908.1	Eub_5
	WP_020594901.1	Eub_6

	WP_028978473.1	Eub_7
	WP_013927919.1	Eub_8
	GAL86272.1	Eub_9
	WP_022831195.1	Eub_10
snap_masked-scaffold10_size447749-processed-gene-3.47	XP_312302.3	Met_1
	XP_001865713.1	Met_2
	XP_011197091.1	Met_3
	CEF66560.1	Met_4
	ENN77452.1	Met_5
	NP_732486.2	D_mel
	NP_493371.1	C_ele
	EKC36313.1	C_gig
	NP_001264720.1	G_gal
	XP_001633029.1	N_vec
	XP_006683531.1	Fun_1
	GAA84667.1	Fun_2
	XP_003719896.1	Fun_3
	AAF70241.1	Fun_4
	XP_001905685.1	Fun_5
	EMH76643.1	Pro_1
	EPY29093.1	Pro_2
	XP_005794540.1	Pro_3
	XP_003875179.1	Pro_4
	XP_002960024.1	Pro_5
	BAJ96758.1	Pla_1
	XP_002540035.1	Pla_2
	XP_002539462.1	Pla_3
	KEH15495.1	Pla_4
	WP_016358292.1	Arc_1
	WP_040681982.1	Arc_2
	WP_012021384.1	Arc_3
	WP_013775700.1	Arc_4
	WP_015581549.1	Arc_5
	WP_022830972.1	Eub_1
	WP_015028079.1	Eub_2
	WP_028667651.1	Eub_3
	WP_034257606.1	Eub_4
	WP_025864949.1	Eub_5
	WP_020601462.1	Eub_6
	WP_013444421.1	Eub_7
	WP_015329810.1	Eub_8
	WP_018620330.1	Eub_9
	WP_028730375.1	Eub_10
augustus_masked-scaffold15023_size6066-processed-gene-0.3	ELT98248.1	Met_1
	XP_009288522.1	Met_2

	CDW59419.1	Met_3
	KII74601.1	Met_4
	XP_003390337.1	Met_5
	XP_001620472.1	N_vec
	KGQ13221.1	Fun_1
	KGQ13835.1	Fun_2
	XP_007406412.1	Fun_3
	XP_003334153.2	Fun_4
	KFY99255.1	Fun_5
	EMH77043.1	Pro_1
	GAM19526.1	Pro_2
	NP_045215.1	Pro_3
	EAR81937.2	Pro_4
	XP_001460950.1	Pro_5
	XP_002539997.1	Pla_1
	XP_002536709.1	Pla_2
	XP_001786863.1	Pla_3
	XP_002536685.1	Pla_4
	XP_001786672.1	Pla_5
	AIA86359.1	Arc_1
	WP_008321096.1	Arc_2
	WP_013906266.1	Arc_3
	AHZ21692.1	Arc_4
	AIU70933.1	Arc_5
	WP_009855471.1	Eub_1
	WP_014426505.1	Eub_2
	WP_009549535.1	Eub_3
	WP_026096412.1	Eub_4
	WP_026354497.1	Eub_5
	WP_038494969.1	Eub_6
	WP_036214541.1	Eub_7
	WP_009667571.1	Eub_8
	WP_036237415.1	Eub_9
	WP_038487188.1	Eub_10
maker-scaffold3763_size17107-snap-gene-0.14	EHA22259.1	Fun_1
	EMD32372.1	Fun_2
	KEP51556.1	Fun_3
	KEP51555.1	Fun_4
	KIK36698.1	Fun_5
	XP_001261871.1	Fun_6
	KDR79180.1	Fun_7
	XP_009551738.1	Fun_8
	EPS99280.1	Fun_9
	XP_005651358.1	Pro_1
	XP_002894880.1	Pro_2

	XP_001778913.1	Pla_1
	XP_002536324.1	Pla_2
	EMT11668.1	Pla_3
	WP_014763218.1	Eub_1
	WP_008878470.1	Eub_2
	KIG17217.1	Eub_3
	WP_006727887.1	Eub_4
	WP_035072033.1	Eub_5
snap_masked-scaffold8578_size10052-processed-gene-0.10	ETN86856.1	Met_1
	XP_003390865.1	Met_2
	XP_010724977.1	Met_3
	XP_007244265.1	Met_4
	XP_010884639.1	Met_5
	NP_612044.1	D_mel
	NP_001021052.1	C_ele
	EKC25730.1	C_gig
	XP_002741389.1	S_kow
	XP_416988.1	G_gal
	XP_001618871.1	N_vec
	XP_006683287.1	Fun_1
	XP_006683290.1	Fun_2
	XP_002650527.1	Fun_3
	CDH53780.1	Fun_4
	ERZ94801.1	Fun_5
	XP_004184621.1	Pro_1
	XP_641641.1	Pro_2
	CBK22816.2	Pro_3
	GAM23706.1	Pro_4
	XP_002293037.1	Pro_5
	XP_002540080.1	Pla_1
	XP_002539007.1	Pla_2
	XP_010109352.1	Pla_3
	XP_006484833.1	Pla_4
	XP_007215006.1	Pla_5
	AIF05098.1	Arc_1
	BAP60490.1	Arc_2
	WP_011972221.1	Arc_3
	WP_010870574.1	Arc_4
	WP_007043598.1	Arc_5
	WP_040546614.1	Eub_1
	WP_020035461.1	Eub_2
	ADI22501.1	Eub_3
	ADE54680.1	Eub_4
	WP_040900913.1	Eub_5
	WP_015049434.1	Eub_6

	WP_009851810.1	Eub_7
	WP_018294071.1	Eub_8
	WP_027985653.1	Eub_9
	WP_008516497.1	Eub_10
maker-scaffold749_size36498-snap-gene-0.17	AGR65713.1	Met_1
	XP_002435205.1	Met_2
	XP_002118601.1	Met_3
	XP_008486101.1	Met_4
	ELT91828.1	Met_5
	NP_649139.1	D_mel
	NP_741194.1	C_ele
	EKC25219.1	C_gig
	XP_006819552.1	S_kow
	NP_001006567.1	G_gal
	XP_001640743.1	N_vec
	EPY49588.1	Fun_1
	EPX75052.1	Fun_2
	KGK38776.1	Fun_3
	XP_002553905.1	Fun_4
	XP_002777738.1	Fun_5
	XP_002140155.1	Pro_1
	XP_002179030.1	Pro_2
	XP_002285941.1	Pro_3
	XP_001293713.1	Pro_4
	XP_009034222.1	Pro_5
	XP_002540194.1	Pla_1
	KHG27573.1	Pla_2
	XP_004146302.1	Pla_3
	XP_009120277.1	Pla_4
	XP_004163726.1	Pla_5
	WP_012956882.1	Arc_1
	AIF83870.1	Arc_2
	AIC14683.1	Arc_3
	WP_014963178.1	Arc_4
	WP_017981048.1	Arc_5
	WP_009577742.1	Eub_1
	WP_039751929.1	Eub_2
	WP_013453160.1	Eub_3
	WP_038033009.1	Eub_4
	WP_017731758.1	Eub_5
	WP_035726303.1	Eub_6
	WP_026898535.1	Eub_7
	GAL84230.1	Eub_8
	WP_037576558.1	Eub_9
	WP_040006875.1	Eub_10

Genomic PCR – associated information

Genl. reference	Gene 1	Gene 1 best hit	Gene 1 HGT index score	Gene 1 Putative annotation	Gene 1 BLAST % ID	Gene 1 product length (AA)	Gene 1 top hit length (AA)	Gene 1 domain	Gene 1 domain link	Gene 2	Gene 2 best hit
41	maker-scalfold1034_size31628-processed-gene-0.19	g51446019refWP_021044668.1	25	ABC-type branched-chain amino acid transport system, ATPase component	53.04	482	252	ABC	g0262346refWP_025090671.1	maker-scalfold1034_size31628-processed-gene-0.19	g51446019refWP_021044668.1
42	maker-scalfold4690_size14997-processed-gene-0.16	g50486567refWP_010352778.1	108	exonuclease III	69.69	499	261	Archaeb	g0262346refWP_025090671.1	maker-scalfold4690_size14997-processed-gene-0.16	g50486567refWP_010352778.1
43	maker-scalfold6957_size11554-processed-gene-0.14	g503032157refWP_013666617.1	142	hypothetical protein	43.37	211	219	Archaeb	g0262346refWP_025090671.1	maker-scalfold6957_size11554-processed-gene-0.14	g503032157refWP_013666617.1
44	maker-scalfold7284_size11211-processed-gene-0.10	g549917441refWP_018740981.1	74	hypothetical protein	28.87	412	216	Archaeb	g0262346refWP_025090671.1	maker-scalfold7284_size11211-processed-gene-0.10	g549917441refWP_018740981.1
45	maker-scalfold1047_size2086347-processed-gene-0.78	g526853047refWP_020663177.1	108	hydroxylase	55.27	511	248	Archaeb	g0262346refWP_025090671.1	maker-scalfold1047_size2086347-processed-gene-0.78	g526853047refWP_020663177.1
46	maker-scalfold1000_size20066-processed-gene-0.59	g5095484122gEXX71234.1	189	hypothetical protein Ref: 080310	28.59	869	737	Fungi	g0262346refWP_025090671.1	maker-scalfold1000_size20066-processed-gene-0.59	g5095484122gEXX71234.1
47	augustus masked-scalfold1002_size2014-processed-gene-0.4	g57547149refWP_006657044.1	211	hypothetical protein BAT1EDRAFT_8747	42.86	511	445	Fungi	g0262346refWP_025090671.1	augustus masked-scalfold1002_size2014-processed-gene-0.4	g57547149refWP_006657044.1
48	maker-scalfold1011_size89954-processed-gene-0.1	g5499103713gEXX79024.1	199	hypothetical protein Ref: 090241	28.21	599	219	Fungi	g0262346refWP_025090671.1	maker-scalfold1011_size89954-processed-gene-0.1	g5499103713gEXX79024.1
49	maker-scalfold104_size4685-augustus-gene-0.25	g50954760refWP_006657044.1	242	hypothetical protein Ref: 114100	33.27	824	500	Fungi	g0262346refWP_025090671.1	maker-scalfold104_size4685-augustus-gene-0.25	g50954760refWP_006657044.1
50	maker-scalfold1055_size34456-augustus-gene-0.19	g5170107261refWP_001848441.1	381	delta 9-fatty acid desaturase protein	65.8421	432	465	Fungi	g0262346refWP_025090671.1	maker-scalfold1055_size34456-augustus-gene-0.19	g5170107261refWP_001848441.1
51	maker-scalfold10741_size634-augustus-gene-0.6	g534097461gEXX18088.1	44	COPII coat assembly protein SEC16	33.12	943	199	Fungi	g0262346refWP_025090671.1	maker-scalfold10741_size634-augustus-gene-0.6	g534097461gEXX18088.1
52	maker-scalfold1092_size39006-processed-gene-0.25	g514697461gEXX18088.1	44	COPII coat assembly protein SEC16	33.33	940	199	Fungi	g0262346refWP_025090671.1	maker-scalfold1092_size39006-processed-gene-0.25	g514697461gEXX18088.1
53	maker-scalfold1218_size29458-augustus-gene-0.15	g5296411889refWP_002835661.1	605	hypothetical protein	56.21	1143	571	Fungi	g0262346refWP_025090671.1	maker-scalfold1218_size29458-augustus-gene-0.15	g5296411889refWP_002835661.1
54	map maker-scalfold1229_size2934-processed-gene-0.12	g52059139gEXX05599.1	130	including n-acylase of ribosomal protein	37.13	1472	211	Fungi	g0262346refWP_025090671.1	map maker-scalfold1229_size2934-processed-gene-0.12	g52059139gEXX05599.1
55	augustus masked-scalfold1669_size2541-processed-gene-0.3	g52194522gEXX05602.1	303	hypothetical protein mv_R860	39.92	567	558	Viruses	g0262346refWP_025090671.1	augustus masked-scalfold1669_size2541-processed-gene-0.3	g52194522gEXX05602.1
56	map maker-scalfold2358_size21708-processed-gene-0.4	g537194522gEXX05602.1	326	hypothetical protein mv_R860	39.75	1462	554	Viruses	g0262346refWP_025090671.1	map maker-scalfold2358_size21708-processed-gene-0.4	g537194522gEXX05602.1
57	maker-scalfold301_size53378-augustus-gene-0.31	g537194522gEXX05602.1	326	hypothetical protein mv_R860	38.4	548	554	Viruses	g0262346refWP_025090671.1	maker-scalfold301_size53378-augustus-gene-0.31	g537194522gEXX05602.1
58	maker-scalfold3259_size18493-processed-gene-0.15	g537194522gEXX05602.1	326	hypothetical protein mv_R860	38.26	557	554	Viruses	g0262346refWP_025090671.1	maker-scalfold3259_size18493-processed-gene-0.15	g537194522gEXX05602.1
59	maker-scalfold5591_size22279-augustus-gene-0.10	g537194522gEXX05602.1	326	hypothetical protein mv_R860	36.98	620	554	Viruses	g0262346refWP_025090671.1	maker-scalfold5591_size22279-augustus-gene-0.10	g537194522gEXX05602.1
60	maker-scalfold5737_size10937-processed-gene-0.9	g538259944refWP_009001021.1	66	collagen triple helix repeat protein	64.46	349	709	Viruses	g0262346refWP_025090671.1	maker-scalfold5737_size10937-processed-gene-0.9	g538259944refWP_009001021.1
61	augustus masked-scalfold847_size3439-processed-gene-0.4	g537194522gEXX05602.1	349	hypothetical protein mv_R860	38.86	567	554	Viruses	g0262346refWP_025090671.1	augustus masked-scalfold847_size3439-processed-gene-0.4	g537194522gEXX05602.1
62	maker-scalfold10_size47749-processed-gene-0.25	g53043359refWP_013688259.1	66	hydroxylase	65.31	188	98	Bacteroidetes	g0262346refWP_025090671.1	maker-scalfold10_size47749-processed-gene-0.25	g53043359refWP_013688259.1
63	maker-scalfold10072_size9001-processed-gene-0.11	g5389614179gEXX185499.1	910	hypothetical protein	64.17	982	735	Bacteria	g0262346refWP_025090671.1	maker-scalfold10072_size9001-processed-gene-0.11	g5389614179gEXX185499.1
64	maker-scalfold16610_size5253-processed-gene-0.7	g550462602refWP_028292962.1	491	hypothetical protein	88.11	1020	285	Bacteria	g0262346refWP_025090671.1	maker-scalfold16610_size5253-processed-gene-0.7	g550462602refWP_028292962.1
65	map maker-scalfold161703_size521-processed-gene-0.5	g50540911refWP_015962333.1	845	chromosomal replication initiator protein DnaA	68.05	511	506	Bacteria	g0262346refWP_025090671.1	map maker-scalfold161703_size521-processed-gene-0.5	g50540911refWP_015962333.1
66	augustus masked-scalfold16703_size2513-processed-gene-0.3	g51821362refWP_019403833.1	53	enoyl-CoA hydratase	80.65	125	257	Bacteria	g0262346refWP_025090671.1	augustus masked-scalfold16703_size2513-processed-gene-0.3	g51821362refWP_019403833.1
67	maker-scalfold10066_size9005-processed-gene-0.15	g55001362refWP_011830907.1	520	HncA family transcriptional regulator	71.87	449	342	Bacteria	g0262346refWP_025090671.1	maker-scalfold10066_size9005-processed-gene-0.15	g55001362refWP_011830907.1
68	maker-scalfold714_size1728-augustus-gene-0.12	g529334553refWP_001169713.1	207	acylglycerolcholine transferase	37.83	388	388	Fungi	g0262346refWP_025090671.1	maker-scalfold714_size1728-augustus-gene-0.12	g529334553refWP_001169713.1
69	maker-scalfold5591_size22279-augustus-gene-0.10	g529334553refWP_001169713.1	207	acylglycerolcholine transferase	37.83	388	388	Fungi	g0262346refWP_025090671.1	maker-scalfold5591_size22279-augustus-gene-0.10	g529334553refWP_001169713.1
70	map maker-scalfold10029_size9013-processed-gene-0.14	g501209330gEXXZP5172.1	362	hypothetical protein SEL_MORAFAT_96185	76.17	219	288	Bacteria	g0262346refWP_025090671.1	map maker-scalfold10029_size9013-processed-gene-0.14	g501209330gEXXZP5172.1
71	maker-scalfold505_size12078-augustus-gene-0.8	g51880083refWP_001753211.1	319	predicted protein	40.61	573	581	Fungi	g0262346refWP_025090671.1	maker-scalfold505_size12078-augustus-gene-0.8	g51880083refWP_001753211.1
72	maker-scalfold1003_size47749-processed-gene-0.5	g53043359refWP_013688259.1	66	hydroxylase	65.31	188	98	Bacteroidetes	g0262346refWP_025090671.1	maker-scalfold1003_size47749-processed-gene-0.5	g53043359refWP_013688259.1
73	map maker-scalfold10_size47749-processed-gene-0.25	g53120292refWP_028300749.1	359	endo-1,4-beta-xylosylase	71.04	205	295	Bacteria	g0262346refWP_025090671.1	map maker-scalfold10_size47749-processed-gene-0.25	g53120292refWP_028300749.1
74	map maker-scalfold878_size37947-processed-gene-0.18	g51531077refWP_016848406.1	235	omega-ACP reductase	67.77	273	275	Bacteria	g0262346refWP_025090671.1	map maker-scalfold878_size37947-processed-gene-0.18	g51531077refWP_016848406.1
75	map maker-scalfold40102_size903-processed-gene-0.12	g54986986refWP_010403119.1	478	YnfL family transcriptional regulator	84.8	299	299	Bacteria	g0262346refWP_025090671.1	map maker-scalfold40102_size903-processed-gene-0.12	g54986986refWP_010403119.1
76	maker-scalfold12066_size780-processed-gene-0.3	g5189252refWP_020848179.1	232	lysine aminopeptidase	69.12	274	274	Bacteria	g0262346refWP_025090671.1	maker-scalfold12066_size780-processed-gene-0.3	g5189252refWP_020848179.1
77	maker-scalfold2326_size18566-augustus-gene-0.24	g530276252refWP_002866650.1	265	hypothetical protein SEL_MORAFAT_266960	45.95	382	418	Fungi	g0262346refWP_025090671.1	maker-scalfold2326_size18566-augustus-gene-0.24	g530276252refWP_002866650.1
78	maker-scalfold1707_size25220-processed-gene-0.10	g512555456gEXXZ001251.1	409	hypothetical protein Df_2158	39.32	844	384	Fungi	g0262346refWP_025090671.1	maker-scalfold1707_size25220-processed-gene-0.10	g512555456gEXXZ001251.1
79	maker-scalfold1372_size27931-augustus-gene-0.18	g514594753refWP_018499212.1	167	Trf family transcriptional regulator	49.67	318	285	Bacteria	g0262346refWP_025090671.1	maker-scalfold1372_size27931-augustus-gene-0.18	g514594753refWP_018499212.1
80	map maker-scalfold21250_size389-processed-gene-0.4	g50114352refWP_012191727.1	147	Ynf family transcriptional regulator	46.07	318	195	Bacteria	g0262346refWP_025090671.1	map maker-scalfold21250_size389-processed-gene-0.4	g50114352refWP_012191727.1
81	maker-scalfold12726_size10414-processed-gene-0.15	g527718123refWP_014482632.1	277	MuL1/TSXP_C15_mnase ABC transporter ATP-binding protein	68.59	511	506	Bacteria	g0262346refWP_025090671.1	maker-scalfold12726_size10414-processed-gene-0.15	g527718123refWP_014482632.1
82	map maker-scalfold48578_size10052-processed-gene-0.10	g549465502refWP_007412967.1	583	polyaccharide biosynthesis protein CapD	51.27	626	674	Bacteria	g0262346refWP_025090671.1	map maker-scalfold48578_size10052-processed-gene-0.10	g549465502refWP_007412967.1
83	maker-scalfold22270_size2748-processed-gene-0.5	g544671101refWP_000808275.1	522	salI/ate ABC transporter ATP-binding protein	60.32	608	636	Bacteria	g0262346refWP_025090671.1	maker-scalfold22270_size2748-processed-gene-0.5	g544671101refWP_000808275.1
84	maker-scalfold486_size12099-processed-gene-0.18	g549287551refWP_006018912.1	296	MuL1/TSXP_C15_hypothetical protein	71.83	520	338	Bacteria	g0262346refWP_025090671.1	maker-scalfold486_size12099-processed-gene-0.18	g549287551refWP_006018912.1
85	maker-scalfold1216_size27123-processed-gene-0.15	g51821362refWP_019403833.1	53	enoyl-CoA hydratase	81.48	125	125	Bacteria	g0262346refWP_025090671.1	maker-scalfold1216_size27123-processed-gene-0.15	g51821362refWP_019403833.1
86	map maker-scalfold1455_size271423-processed-gene-0.8	g51745637refWP_018627148.1	458	glutamy-tRNA synthetase	66.52	529	509	Bacteria	g0262346refWP_025090671.1	map maker-scalfold1455_size271423-processed-gene-0.8	g51745637refWP_018627148.1
87	map maker-scalfold126_size1740-processed-gene-0.47	g50267567refWP_012191419.1	199	phosco-6-phosphate 1-dehydrogenase	53.93	567	486	Bacteria	g0262346refWP_025090671.1	map maker-scalfold126_size1740-processed-gene-0.47	g50267567refWP_012191419.1
88	maker-scalfold1068_size10433-processed-gene-0.1	g529334553refWP_001169713.1	207	acylglycerolcholine transferase	37.83	388	388	Fungi	g0262346refWP_025090671.1	maker-scalfold1068_size10433-processed-gene-0.1	g529334553refWP_001169713.1
89	augustus masked-scalfold10029_size9013-processed-gene-0.14	g501209330gEXXZP5172.1	362	hypothetical protein SEL_MORAFAT_96185	76.17	219	288	Bacteria	g0262346refWP_025090671.1	augustus masked-scalfold10029_size9013-processed-gene-0.14	g501209330gEXXZP5172.1
90	maker-scalfold49976_size29233-processed-gene-0.1	g517548072refWP_006679675.1	115	myosin heavy chain variant 1	49.08	469	565	Fungi	g0262346refWP_025090671.1	maker-scalfold49976_size29233-processed-gene-0.1	g517548072refWP_006679675.1
91	maker-scalfold1970_size20333-augustus-gene-0.15	g517548072refWP_006679675.1	115	myosin heavy chain variant 1	49.08	469	565	Fungi	g0262346refWP_025090671.1	maker-scalfold1970_size20333-augustus-gene-0.15	g517548072refWP_006679675.1
92	maker-scalfold1455_size271423-processed-gene-0.60	g51745637refWP_018627148.1	458	glutamy-tRNA synthetase	66.52	529	509	Bacteria	g0262346refWP_025090671.1	maker-scalfold1455_size271423-processed-gene-0.60	g51745637refWP_018627148.1
93	maker-scalfold74_size15697-processed-gene-0.80	g517191819gEXXZT4744.1	116	alpha/beta hydrolase	53.85	286	286	Bacteria	g0262346refWP_025090671.1	maker-scalfold74_size15697-processed-gene-0.80	g517191819gEXXZT4744.1
94	maker-scalfold3315_size18230-processed-gene-0.10	g5159401581refWP_012134317.1	183	cytine hydratase	65.38	267	156	Bacteria	g0262346refWP_025090671.1	maker-scalfold3315_size18230-processed-gene-0.10	g5159401581refWP_012134317.1
95	maker-scalfold5060_size27859-augustus-gene-0.17	g53043359refWP_013688259.1	66	hydroxylase	65.31	188	98	Bacteroidetes	g0262346refWP_025090671.1	maker-scalfold5060_size27859-augustus-gene-0.17	g53043359refWP_013688259.1
96	maker-scalfold2709_size20194-processed-gene-0.9	g53043359refWP_013688259.1	66	hydroxylase	65.31	188	98	Bacteroidetes	g0262346refWP_025090671.1	maker-scalfold2709_size20194-processed-gene-0.9	g53043359refWP_013688259.1

Gene 2 product length (AA)	Gene 2 best hit length (AA)	Gene 2 domain	Gene 2 kingdom	Gene 2 Phylum	Gene 1 START	Gene 1 END	Gene 2 Start	Gene 2 END	Forward Primer Sequence	Reverse Primer Sequence	Reverse Primer Start	Reverse Primer End	Predicted amplicon length	Gene 1 Intron Count
407	394	#N/A	#N/A	#N/A	979	979	979	2202	ATGGGAAAGAC	ATGGGAAAGAC	2002	2002	3163	1
242	242	Bacteria	#N/A	#N/A	6885	6952	6885	8820	ATGGCACTCCGGTGAAC	ATGGCACTCCGGTGAAC	5884	5884	6269	2
185	139	Bacteria	#N/A	#N/A	5863	3871	5863	4599	ACCGACCAAAAGTCAAC	ACCGACCAAAAGTCAAC	4404	4404	5633	1
250	250	Eukaryota	Metazoa	Chordata	71	2666	3388	8533	CCACCATTCGACACTCTT	CCACCATTCGACACTCTT	2472	2472	3490	10
281	262	Bacteria	#N/A	#N/A	2538	2538	2538	878	ATGCGTCAAGCC	ATGCGTCAAGCC	802	802	1098	0
685	750	Eukaryota	Metazoa	Chordata	695231	77997	62373	67402	GATCTTACGGTACGGCTGAG	GATCTTACGGTACGGCTGAG	67307	67307	69658	2452
685	513	Eukaryota	Metazoa	Chordata	20996	24776	13432	18629	ATGCCAAACCTACCTAGAC	ATGCCAAACCTACCTAGAC	1862	1862	5333	9
701	970	Eukaryota	Metazoa	Chordata	700423	700423	700423	178	ATGAGCACTGACGATATTG	ATGAGCACTGACGATATTG	5028	5028	4379	1168
694	663	Eukaryota	Metazoa	Chordata	55904	61118	50678	54487	TCCATATCCGGTAAAGTGTTC	TCCATATCCGGTAAAGTGTTC	54300	54300	56041	1742
638	406	Eukaryota	Metazoa	Arthropoda	5378	8390	480	5914	CTTGGAGGAGCGTAGAGAAG	CTTGGAGGAGCGTAGAGAAG	3830	3830	4741	3
186	883	Eukaryota	Metazoa	Platyhelminthes	381	6605	2778	8112	AAATACTTGAGAGGCTAATC	AAATACTTGAGAGGCTAATC	6410	6410	7477	1088
145	169	Eukaryota	Metazoa	Tardigrada	111	5841	6761	1830	AGTCCAAATACTCGATGC	AGTCCAAATACTCGATGC	564	564	6791	1151
530	128	Eukaryota	Chordata	6366	22424	30	4639	AACCAACAGTGTGACCAAAGAC	AACCAACAGTGTGACCAAAGAC	4660	4660	6736	1677	
364	359	Bacteria	#N/A	#N/A	9128	17403	4178	7351	AGCTGATGGTAAAGGCAATC	AGCTGATGGTAAAGGCAATC	7208	7208	9308	2104
954	434	Eukaryota	Metazoa	Mollusca	17379	24176	10380	17308	TGATGCTCCCAAGTGGTGG	TGATGCTCCCAAGTGGTGG	1747	1747	1794	504
687	544	Eukaryota	Metazoa	Arthropoda	18906	21636	8357	17906	CGGACCGACTGAGGTGG	CGGACCGACTGAGGTGG	17786	17786	19061	1356
823	1091	Eukaryota	Metazoa	Arthropoda	47538	51889	38411	47115	TCACTACAGTCTCTGGGTGAG	TCACTACAGTCTCTGGGTGAG	46976	46976	47712	737
61	1007	Eukaryota	Metazoa	Chordata	4251	7843	1315	2250	ACGGGCGTATCATCTTC	ACGGGCGTATCATCTTC	2186	2186	4417	252
192	141	Eukaryota	Metazoa	Cnidaria	496	8823	1573	4081	CGGACCAACAGTGAAT	CGGACCAACAGTGAAT	398	398	800	3
186	187	Eukaryota	Metazoa	Cnidaria	9299	10669	6551	9014	GGCAAGACTTGTACTTACTCG	GGCAAGACTTGTACTTACTCG	8754	8754	9425	852
576	531	Eukaryota	Metazoa	Amniota	6229	12881	14329	18974	CGATGCTATGAGGCTATG	CGATGCTATGAGGCTATG	12881	12881	14428	1748
361	360	Bacteria	#N/A	#N/A	284667	285116	281530	28285	CGCCAGCATCTCATATA	CGCCAGCATCTCATATA	28248	28248	28457	210
694	625	Bacteria	#N/A	#N/A	256	3216	4761	8845	CTTGTATCTTCTCCAGAG	CTTGTATCTTCTCCAGAG	3047	3047	3411	1795
329	329	Bacteria	#N/A	#N/A	3222	4429	4	2889	ACCAATAAAGAGATCGAAG	ACCAATAAAGAGATCGAAG	2578	2578	4841	841
115	90	Bacteria	#N/A	#N/A	1488	2991	4377	4724	TTGATCCCTGCTGCTTATC	TTGATCCCTGCTGCTTATC	2977	2977	3451	1515
115	90	Bacteria	#N/A	#N/A	4836	5213	4377	4724	CTTCCAGGCGCAACT	CTTCCAGGCGCAACT	4553	4553	4856	304
333	251	Bacteria	#N/A	#N/A	193	1771	3051	4071	TGAGAGCGGCAAAAGTAT	TGAGAGCGGCAAAAGTAT	1616	1616	3152	1537
502	1233	Eukaryota	Metazoa	Chordata	5087	9251	4	3623	TCTTCGGCAATATGATCAAC	TCTTCGGCAATATGATCAAC	342	342	6748	2337
91	140	Eukaryota	Metazoa	Arthropoda	6993	6993	4407	4773	TCAAGTCTCTCTTCAAGAG	TCAAGTCTCTCTTCAAGAG	3818	3818	4537	643
226	226	Bacteria	#N/A	#N/A	5008	5787	5938	6618	CAGAGAAACCTCCGTGTATG	CAGAGAAACCTCCGTGTATG	5237	5237	6178	70
136	415	Bacteria	#N/A	#N/A	6165	11938	4066	5921	CGATCTCTAATAGCTGAAG	CGATCTCTAATAGCTGAAG	5800	5800	6354	515
1188	457	Bacteria	#N/A	#N/A	1338	1383	3538	4399	TGCTGATGATGAGGATG	TGCTGATGATGAGGATG	3648	3648	3988	0
446	445	Bacteria	#N/A	#N/A	430215	431403	426327	429238	TAGAAGCGTGAACAGAAGAC	TAGAAGCGTGAACAGAAGAC	429047	429047	430321	1275
439	437	Bacteria	#N/A	#N/A	1552	2373	2377	3896	AGTGTCTGCTGTGGGAG	AGTGTCTGCTGTGGGAG	2231	2231	2545	313
291	187	Bacteria	#N/A	#N/A	2079	2084	726	2628	CTGATGCTGCTGCTGCTGAC	CTGATGCTGCTGCTGCTGAC	192	192	2262	262
259	259	Bacteria	#N/A	#N/A	3748	3748	5337	6316	AGTCTCTGCTGCTGCTGAC	AGTCTCTGCTGCTGCTGAC	3580	3580	3838	309
292	292	Eukaryota	Metazoa	Chordata	39	2652	4569	6015	GGATCTATATACCCTAAGC	GGATCTATATACCCTAAGC	2652	2652	3183	625
186	188	Eukaryota	Metazoa	Arthropoda	4439	9842	519	3119	TTGAGCATGCAATCAGGATG	TTGAGCATGCAATCAGGATG	2953	2953	4607	1673
277	328	Eukaryota	Metazoa	Arthropoda	284667	285116	281530	28285	CGCCAGCATCTCATATA	CGCCAGCATCTCATATA	28248	28248	28457	210
151	147	Bacteria	#N/A	#N/A	14873	17814	19720	21637	AGGCGCATACAGACAAG	AGGCGCATACAGACAAG	17603	17603	19825	2223
95	90	Bacteria	#N/A	#N/A	1311	2350	127	582	CAGAAGTACATCTGCCTTC	CAGAAGTACATCTGCCTTC	487	487	968	1
204	200	Bacteria	#N/A	#N/A	7984	9949	7098	7712	TCAAGCTGATGCTTGGTATG	TCAAGCTGATGCTTGGTATG	7557	7557	8102	546
215	279	Bacteria	#N/A	#N/A	653	2501	2	649	ATGGCTGCTGCTGCTGCTGAC	ATGGCTGCTGCTGCTGCTGAC	450	450	616	166
943	514	Bacteria	#N/A	#N/A	6439	8123	690	3885	CGGACCTCTCAAGGAGAG	CGGACCTCTCAAGGAGAG	3798	3798	4678	2781
338	333	Bacteria	#N/A	#N/A	653	3314	314	7703	CAGAAGCAAGACTACAGCTTAC	CAGAAGCAAGACTACAGCTTAC	3112	3112	3619	1917
428	259	Bacteria	#N/A	#N/A	18170	23140	15619	17678	ACCTGTGTAGCTTCTCTG	ACCTGTGTAGCTTCTCTG	17598	17598	18120	523
369	303	Bacteria	#N/A	#N/A	73510	75213	72265	74492	CTAGTCCGGCTATCGCTTCTC	CTAGTCCGGCTATCGCTTCTC	73388	73388	73661	276
1188	1246	Bacteria	#N/A	#N/A	4008	5086	6978	10345	TGCTGATGATGAGGATG	TGCTGATGATGAGGATG	6848	6848	7137	2155
154	154	Bacteria	#N/A	#N/A	2730	4429	5602	6096	CATCCAGCAGGAAAGTACAC	CATCCAGCAGGAAAGTACAC	4299	4299	4798	1
723	918	Eukaryota	Metazoa	Arthropoda	2	4272	5981	9223	GAGAGCGTACAGCTATATATCC	GAGAGCGTACAGCTATATATCC	4190	4190	6124	1966
608	290	Eukaryota	Metazoa	Nemertea	101	2261	6488	6503	CAATCAAGTCAAGAGAGCAATC	CAATCAAGTCAAGAGAGCAATC	286	286	2664	604
191	127	Eukaryota	Metazoa	Chordata	19209	36658	7272	17474	GTACATCTTCAAGTATTAG	GTACATCTTCAAGTATTAG	17295	17295	19379	2085
613	397	Eukaryota	Metazoa	Chordata	73151	72462	62171	68540	ACGTTGGACTCAACATTTGATG	ACGTTGGACTCAACATTTGATG	68357	68357	71482	3126
190	249	Eukaryota	Metazoa	Chordata	1788	9384	123	9007	ATGGAGCGGGTGGTAAATCTG	ATGGAGCGGGTGGTAAATCTG	9041	9041	1068	20
692	757	Eukaryota	Metazoa	Chordata	10682	12862	6211	2217	TGAGCGTCAAGTATTGAG	TGAGCGTCAAGTATTGAG	1807	1807	1807	1
398	505	Eukaryota	Metazoa	Arthropoda	2136	13918	13068	20194	CGGGGAGGTGGTGGTGG	CGGGGAGGTGGTGGTGG	12590	12590	13555	966
281	276	Eukaryota	Metazoa	Arthropoda	7353	10295	11775	16430	TTATTTTGGTGGTGGTGG	TTATTTTGGTGGTGGTGG	10122	10122	11212	3
1004	342	Eukaryota	Metazoa	Arthropoda	19970	22825	9888	14906	ATAGCGAGCTTCAAGCTGTGTC	ATAGCGAGCTTCAAGCTGTGTC	17466	17466	21088	3613
823	1091	Eukaryota	Metazoa	Arthropoda	27928	34426	36411	47115	GACTGATTTGCTGACTGATG	GACTGATTTGCTGACTGATG	34377	34377	36512	2136
340	1440	Eukaryota	Metazoa	Porifera	26919	28940	29409	31084	AATAAGAGCGCTGAGAG	AATAAGAGCGCTGAGAG	28903	28903	29565	663
664	391	Bacteria	#N/A	#N/A	21603	27066	27079	29078	CTCATCCCTCAACGATTCAG	CTCATCCCTCAACGATTCAG	2666	2666	3100	2
407	363	Eukaryota	Metazoa	Amniota	5027	7656	5670	8406	CTGATGCTGCTGCTGCTGAC	CTGATGCTGCTGCTGCTGAC	496	496	527	2
357	473	Eukaryota	Metazoa	Chordata	8978	12590	3819	8043	AACGAGTACATGCTGAC	AACGAGTACATGCTGAC	7953	7953	8264	1204
263	427	Eukaryota	Metazoa	Chordata	37405	40559	43783	45629	TCTAGCTTCAACCTGCTTC	TCTAGCTTCAACCTGCTTC	4046	4046	43871	3426
481	361	Eukaryota	Metazoa	Arthropoda	7623	9099	12355	10937	GTAGAGCGAGTAAAGTGTGAC	GTAGAGCGAGTAAAGTGTGAC	9547	9547	12524	2984
746	736	Eukaryota	Metazoa	Chordata	6518	8376	3384	5722	CXAAGGCAAGCTTGG	CXAAGGCAAGCTTGG	5542	5542	6657	1116
1016	764	Eukaryota	Metazoa	Chordata	46771	60653	37314	45936	TCAATCAAGTCAATCAACC	TCAATCAAGTCAATCAACC	45743	45743	46902	1160
183	205	Eukaryota	Metazoa	Amniota	2440	6116	7528	8718	CGATGATCAAGTCAAGAGCAATC	CGATGATCAAGTCAAGAGCAATC	5923	5923	7794	3
796	683	Eukaryota	Metazoa	Arthropoda	11253	14250	13461	19178	GTAGCTTCAAGGCAAAATAAG	GTAGCTTCAAGGCAAAATAAG	17278	17278	18456	1159
886	870	Eukaryota	Metazoa	Chordata	33613	41061	28449	34105	TCTTCAACTGATCCTCAACC	TCTTCAACTGATCCTCAACC	33454	33454	34278	20
133	108	Eukaryota	Metazoa	Arthropoda	1913	4735	5695	7800	TGCTTCTTAAAGTCTCTC	TGCTTCTTAAAGTCTCTC	456	456	5876	1312
187	524	Bacteria	#N/A	#N/A	78241	78241	78863	79123	ATCCGAGTCAAGATTTGAG	ATCCGAGTCAAGATTTGAG	79263	79263	79864	1337
707	797	Eukaryota	Protist	n	29403	30347	27056	29387	GGCTACGACTTCTTCTTGTC	GGCTACGACTTCTTCTTGTC	28602	28602	30073	1472
951	686	Bacteria	#N/A	#N/A	2464	4455	6885	11599	CTTGGAGCGAGAAAGCAC	CTTGGAGCGAGAAAGCAC	4401	4401	4662	2562
100	713	Eukaryota	Metazoa	Hemichordata	4868	8302								