

Determination of blood glucose using an oxidase-peroxidase system with a non-carcinogenic chromogen

P. TRINDER

Biochemistry Department, Central Laboratory, Royal Infirmary, Sunderland

SYNOPSIS Manual and automated methods for the determination of blood glucose have been devised using an oxidase/peroxidase system, with dl adrenaline, a non-carcinogen, as oxygen acceptor. The manual technique employs a stable single solution protein precipitant and the other reagents used are also stable. The automated methods are operated at 40/hr sample speed and washover between samples, over a very wide concentration range, is negligible.

The Chester Beatty Institute for Cancer Research have recently issued a pamphlet (1966) recommending that where possible o-tolidine and related compounds should not be used. The most widely used oxidase methods for the determination of blood glucose employ the reactions: glucose + glucose oxidase + oxygen = gluconic acid + H₂O₂ and H₂O₂ + peroxidase + chromogen = coloured product.

The chromogens most often used are o-tolidine and o-dianisidine, and an automated method using these had been performed in this laboratory for some time. A suitable non-carcinogenic chromogen was sought as a possible substitute for o-tolidine, and adrenaline which oxidizes to the red compound adrenochrome was examined.

Methods have been worked out for macro and micro automatic analysis and for manual use.

MANUAL METHOD

REAGENTS These are as follows

1 *Protein precipitant* Sodium tungstate Na₂WO₄·2H₂O, 10 g, 10 g of Na₂HPO₄, and 9 g of NaCl are dissolved in 800 ml of water. About 125 ml of N HCl is added to bring the pH to 3.0 (narrow range paper).

The mixture is made up to 1 litre with water. It keeps for at least six months at room temperature.

2 *0.5% w/v dl adrenaline in 0.5 N HCl* Keeps for at least six months at 4°C.

3 *0.1% w/v peroxidase R.Z. 0.6* Keeps for at least 14 days at 4°C.

4 *Colour reagent* One hundred ml of 40% w/v sodium acetate CH₃COONa·3H₂O + 10 ml of Fermcozyme 653

AM + 10 ml of 0.1% peroxidase. Keeps for at least six months at 4°C.

5 *Glucose standards* These are made up as 0.1, 100 mg/100 ml in 0.2% w/v benzoic acid.

PROCEDURE Blood, 0.1 ml, is added to 2.9 ml of protein precipitant contained in a $\frac{3}{8}$ in. cylindrical centrifuge tube. After centrifugation at 2,000 g for five minutes, 2.5 ml of clear supernatant fluid is transferred to a $\frac{3}{8}$ in. tube labelled U. In two $\frac{3}{8}$ in. tubes labelled S and B, 2.9 ml of protein precipitant is placed. To tube B, 0.1 ml of water is added; to tube S, 0.1 ml of a standard containing 200 mg of glucose/100 ml is added. Then 0.5 ml of 0.5% adrenaline and 0.5 ml of colour reagent are added to tube U and 0.6 ml quantities of these solutions are added to tubes S and B. The three tubes are mechanically shaken for 40 minutes. A Unicam SP 500 spectrophotometer is set with B and the optical densities of U and S are read at 500 m μ , using 10 mm cells.

$$\text{Blood glucose (mg/100 ml)} = \frac{\text{O.D. U}}{\text{O.D. S}} \times 200$$

Beer's law is strictly obeyed up to an optical density of 1.0, and there is only a slight deviation up to O.D. 1.5 (Table I).

If greater sensitivity is required, 0.2 ml of the sam-

TABLE I

DATA FOR CALIBRATION GRAPH¹

Glucose (mg/100 ml)	Optical Density
0	0.000
50	0.105
100	0.209
200	0.412
400	0.825
1000	1.980

¹Final volume of sample 4.2 ml.

ple is used with 2.8 ml of the protein precipitant and the appropriate factor is used in the calculation. Occasionally a slight turbidity appears in the solutions. This has very little effect on the results but for very accurate work it is advisable to centrifuge the tubes before taking readings.

Sodium fluoride, 5 mg/ml of blood, has no effect on the readings.

AUTOMATED METHODS

REAGENTS For the macro method use venous blood containing 1 mg NaF, 2 mg (COOK)₂. H₂O/ml.

6 *Diluent* 3% w/v CH₃COONa.3H₂O; 0.5% w/v MgSO₄.7H₂O. 0.5 ml of Brij 35 (Technicon formula) is added per litre.

7 0.05% w/v dl adrenaline in 0.2% w/v benzoic acid Keeps for 14 days at room temperature.

8 *Colour reagent* Five hundred ml of reagent 7 + 5 ml of Fermcozyme 653 AM + 5 ml of reagent 3. Keeps for 24 hours at room temperature.

In the micro method for 1/10 dilutions of blood in 0.1% w/v NaF: 0.2% w/v (COOK)₂. H₂O; 0.9% w/v NaCl.

9 *Diluent* As for the macro method.

10 0.1% w/v dl adrenaline in 0.2% w/v benzoic acid Keeps for 14 days at room temperature.

11 *Colour reagent* Of reagent 10, 100 ml, + 3 ml of Fermcozyme 653 AM + 3 ml of reagent 3. Keeps for 24 hours at room temperature.

12 *Standards* 5 diluted 1/10 in 0.1% w/v NaF: 0.9% w/v NaCl, 0.2% w/v (COOK)₂. H₂O.

PROCEDURES Use the macro and micro manifolds shown in Figures 1 and 2. A.R. chemicals were used where available. The Fermcozyme 653 AM and peroxidase RZ 0.6 were obtained from Hughes and Hughes Limited, 12a High Street Brentwood, Essex. Only dl adrenaline,

obtainable from the Sigma Chemical Co. Limited, 12 Lettice Street, London, SW6, will give a colour which obeys Beer's law strictly up to an OD of 1.0 in the manual method. (dl Adrenaline is now available from Hughes and Hughes Ltd.) L Adrenalines from other sources give some deviation from the law at optical densities over 0.5. The use of a calibration graph will eliminate any errors due to such behaviour but L adrenaline has been preferred for convenience.

RESULTS AND COMMENTS

MANUAL METHOD Recovery of glucose added to EDTA blood which had stood for 48 hours to allow of decomposition of preformed glucose is shown in Table II. The initial glucose level was nil

TABLE II
RECOVERY OF GLUCOSE ADDED TO BLOOD BY
MANUAL METHOD

Glucose Added (mg/100 ml)	Glucose Found (mg/100 ml)	Recovery (%)
0	0	—
50	50.5	101
100	101	101
200	197	98.5
400	400	100
1000	1020	102

and recoveries were almost quantitative. Sodium fluoride, 5 mg/ml of blood, had no effect on the results. It has been reported that uric acid interferes with glucose oxidase methods (Henry, 1964), but the addition of 1 mg uric acid/ml of blood had no effect on the recoveries.

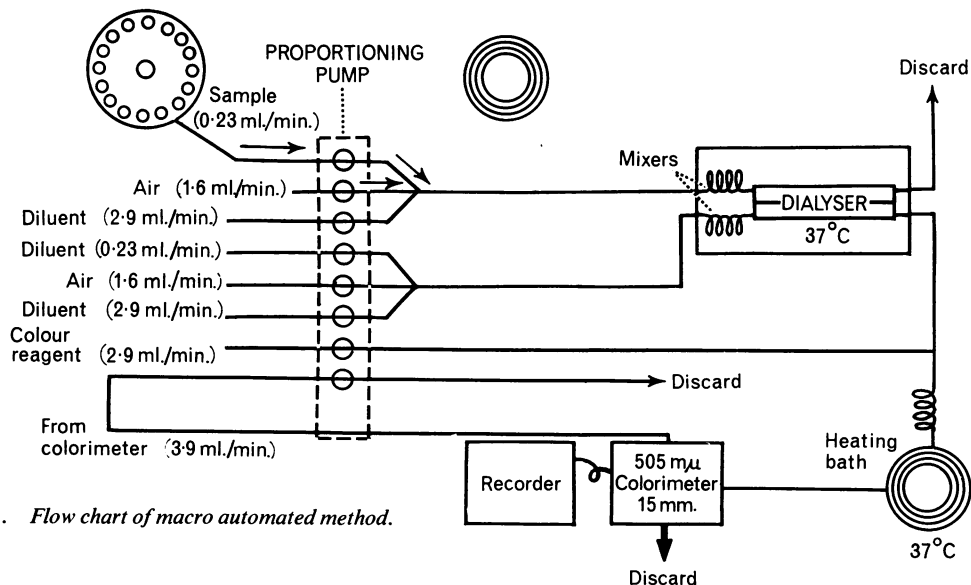

FIG. 1. Flow chart of macro automated method.

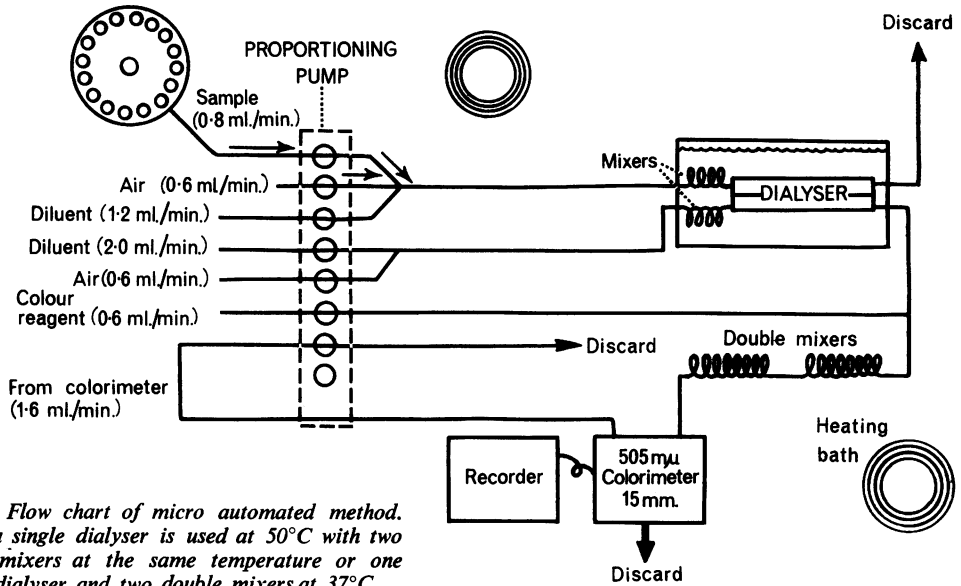

FIG. 2. Flow chart of micro automated method. Either a single dialyser is used at 50°C with two double mixers at the same temperature or one double dialyser and two double mixers at 37°C.

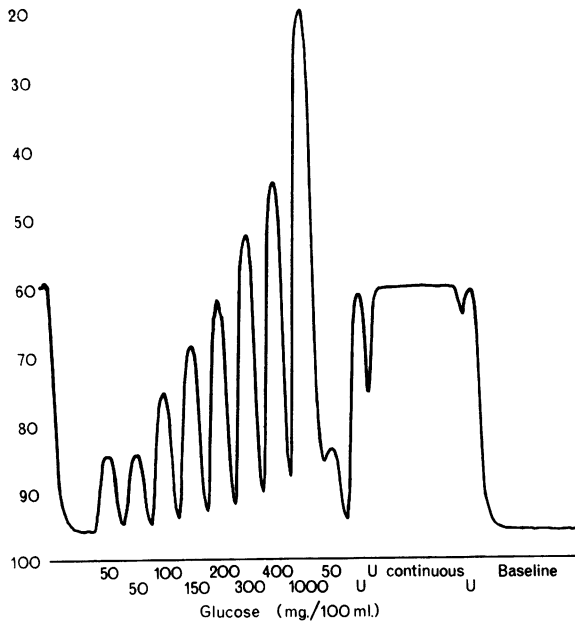

FIG. 3. Typical recording of macro automated method.

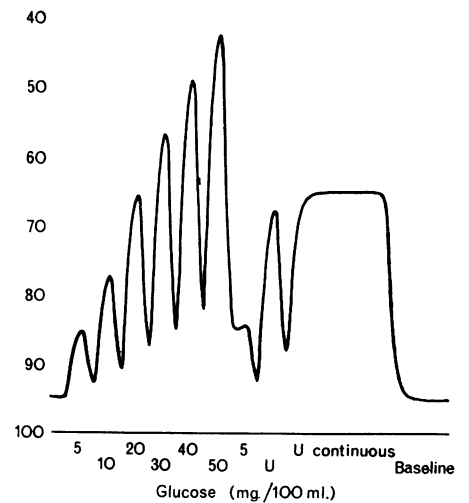

FIG. 4. Typical recording of micro automated method (using single dialysis at 50°C).

AUTOANALYZER METHODS At the 40/hour sampling rate, 1:1 wash ratio using a Pecker attachment to a sampler I, the washover on analysing a sample containing 50 mg glucose/100 ml following one containing 1,000 mg/100 ml was negligible. The micro method is similarly insensitive to washover. Continuous samples on both macro and micro methods gave a horizontal straight line tracing which was only about one transmission line higher than a normal peak from the sample (Figs. 3 and 4). Recoveries of added glucose were similar to those obtained in the manual procedure.

The macro automated technique has been in continuous use for eight months and has proved very satisfactory. The micro automated procedure has been included here for workers who use a 1/10 blood dilution as a routine, but it has not been in continuous use here.

The dl adrenaline reaction was originally worked out for the AutoAnalyzer. The manual method was later included to give a method useful to all laboratories. Initially a two-solution technique was employed using trichloacetic acid/dl adrenaline to precipitate the proteins and sodium acetate/peroxidase/glucose oxidase to develop the colour. This method appeared to be satisfactory and recovery figures were excellent. However, when the method was being tried out in another laboratory, it was found that it gave consistently higher results than a copper reduction/phosphomolybdate method (Asatoor and King, 1954). This was due to the presence of a substance in erythrocytes which gave

TABLE III

COMPARISON OF RESULTS USING THREE METHODS¹

No. of Blood Specimens	Proposed Methods		Arsenomolybdate Method of King and Garner (1947)
	Auto-Analyzer	Manual	
22	111.5	111.1	109.3
44		161.2	162.3

¹Results are values expressed as mg glucose per 100 ml.

a colour with dl adrenaline/sodium acetate/peroxidase in the absence of glucose oxidase. The technique given here eliminates this error but it is not so convenient as the original technique, which required the use of only two solutions and colour development was complete in 20 minutes. Further work is required to develop a more sensitive manual method.

I should like to thank Dr P. N. Coleman, consultant pathologist, Friarage Hospital, Northallerton, for pointing out the error in the original manual method. Thanks are also due to Dr R. A. M. Case, Professor of Social Medicine, Chester Beatty Research Institute, London, for guidance on the non-carcinogenic nature of adrenaline.

REFERENCES

Asatoor, A. M., and King, E. J. (1954). *Biochem J.*, **56**, xlv.
 Chester Beatty Research Institute (1966). *Precautions for Laboratory Workers Who Handle Carcinogenic Aromatic Amines*. Institute of Cancer Research, London.
 Henry, R. J. (1964). *Clinical Chemistry, Principles and Technics*, p. 634. Hoeber, New York. (or repr., 1966).
 King, E. J., and Garner, R. J. (1947). *J. clin. Path.*, **1**, 30.