

## GONIOSCOPY AND ARTEFACTS\*

BY

K. E. SCHIRMER

*From the Glaucoma Clinic, Queen Mary Veterans Hospital, and the Eye Clinic, St Mary's Hospital, Montreal, Canada*

IN gonioscopy, the Koeppelens renders an image that is upright, virtual, and enlarged. This is loupe-type magnification and imagery, and the accompanying distortions must be considered (Fig. 1). The observed object becomes increasingly magnified with the increase of distance between lens and object. Thus an iris detail at the "angle entrance" will be magnified in width and breadth out of proportion to details of the iris closer to the observer. As visual judgment is influenced by the context and the surroundings within which the viewed object appears, it is easy to overestimate a slight iris protrusion opposite Schwalbe's line at the "entrance" of the angle, especially when projected over other details of the angle (trabeculum). A paradoxically increased parallax shift of distant objects with magnification makes it difficult to retain visual judgment. When the angle of gonioscopic observation is flattened, an iris protrusion opposite Schwalbe's line will increase out of proportion to actual change of position of the observer. Different positions of the gonioscope give vastly different impressions of the angle.

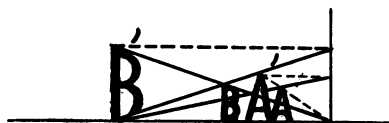

FIG. 1.—Loupe magnification increases with distance between lens and object. Letter "A" is slightly enlarged (A'), while "B" is considerably more magnified (B'). The corresponding details on the iris for "A" (black plaque) and for "B" (iris hump) are similarly magnified.



The magnification of an object when viewed through a loupe depends not only on the curve of the lens, but also on its tilt, *i.e.* the angle of observation.

When the line of observation passes through one side of the gonio lens, prismatic

\* Read before the Montreal Ophthalmological Society in March, 1965. Received for publication July 27, 1965.

distortion is added, including the compression of details and the warping of flat surfaces. With contact between cornea and lens and little difference in refractive indices, this effect is greatly lessened.

These optical effects influence the final image of the angle, although some of them act in opposite directions and so cancel each other partially. A normal angle appears narrower when a convex surface of a Troncoso gonio lens is used than when the angle is viewed through a plano surface with relative freedom from distortion, the only artefact being a shift of the virtual image closer to the observer. The field of observation is large. More than one-third of the circumference can be viewed from one position of the gonioscope. A shift to the convex surface of the lens gives higher magnification of a smaller field.

A plano surface is utilized with the gonio-mirror of Goldmann, the gonio lens of Worst and Otter (1961), and a plano-faceted Troncoso lens (Schirmer, 1964). With the gonio-mirror lens, the area of angle surveyed is limited by the size of the single mirror. Bell's phenomenon, which is almost inevitable as a defence mechanism, causes a change in ocular position and contributes to corneal compression. This aids in the observation of the angle at the 6 o'clock position, but impedes it at the 12 o'clock position (Fig. 2). From this it is obvious that not only optical distortions must be considered in gonioscopy, but actual mechanical distortion of the angle as indicated by the diagram (Figs 2 and 3). Depending on the position of the lens, pressure over Schwalbe's line may narrow the angle. Pressure upon the cornea will force aqueous into the opposite segment of the angle and cause effective local widening. This must be considered when pressure is unintentionally applied at the top of the lens or if the patient closes his lids forcefully over the flange of a tilted contact lens. Pressure over the limbal area is considered mainly when using contact lenses for examining purposes, with a diameter of the contact area of about 15 mm. A Troncoso lens of 20 mm. diameter will hardly become tilted to the extent that an edge will press upon the limbus. By pressing at the top of the lens, however, it is possible to deepen the angle, providing contact fluid escapes from the space between

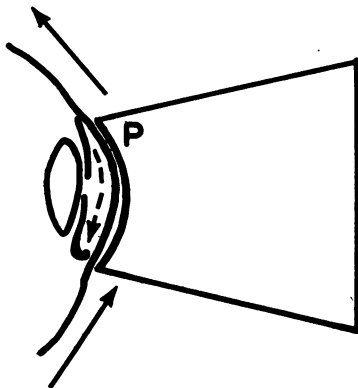

FIG. 2.—Pressure by the lens upon the cornea (P) flattens the angle where pressure is applied. Aqueous is pushed into the opposite segment of the angle. The solid arrows indicate the upward torsion of the eye with Bell's phenomenon which is responsible for the pressure applied on the cornea.

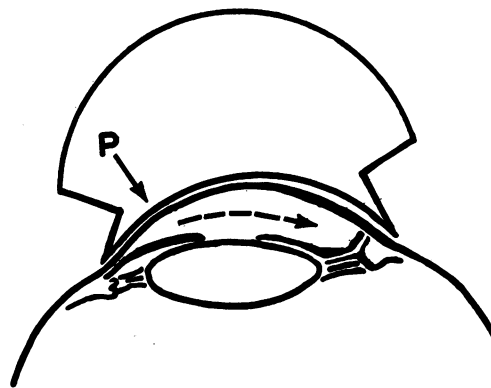

FIG. 3.—Pressure of the Koeppel lens over Schwalbe's line decreases depth of angle locally and increases depth in the opposite area of the angle by shift of aqueous (interrupted arrow).

a steeply based lens and the cornea, which allows the cornea to bulge. In some cases, a valve mechanism is set up that permits fluid to escape on pressure from the contact area without air becoming aspirated, so that after the release of pressure, a low "vacuum" suction is created. This depends also on the base curve of the contact lens. A flat based lens, on the contrary, will compress the cornea and press aqueous into the angle.

The best method of gonioscopy must therefore be one that eliminates "optical" and "mechanical" artefacts. However, mechanical angle distortion has been experimentally induced in normal and pathological angles to assess the extent of possible artefact, to eliminate error and to gain information on normal and glaucomatous angles.

#### Method of Examination and Results

Viewing through a flat surface permits observation of a large part of the circumference of the angle. This plano surface may be either ground into a Troncoso lens as a facet or obtained by a mobile "piggy-back" concave-plano lens (Schirmer, 1965) that fits over the convex lens (Fig. 4). A mobile gonioscope (Fig. 5, opposite), preferably with independent suspension and adjustable slit illumination, assures freedom of positioning and ease of focusing.

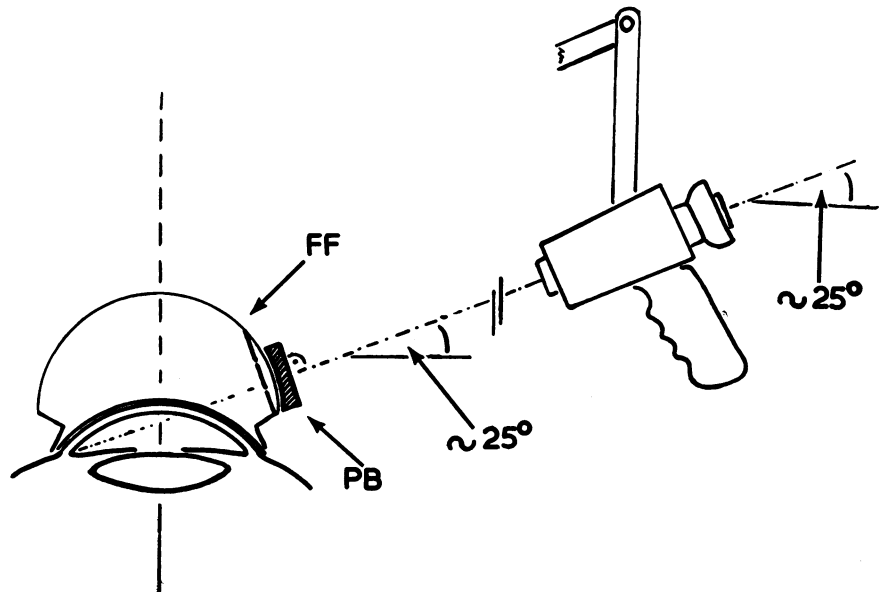

FIG. 4.—Gonioscopy with accurately reproducible conditions. FF: Line of fixed facet. PB: Mobile plano facet ("piggy-back" lens).

An inclination of the gonioscope of about 25 to 30° permits good vision into the angle recess (Fig. 4), with the surface of the facet at right angles. This gives comparable conditions in examining the same angle on different occasions or comparing different angles and attempting goniometry with a millimetre grid in the ocular.

The angle may be mechanically closed or opened, depending on the point of pressure that the contact lens exerts. This resulting shift of fluid (Fig. 3) may open a narrow angle just as well as the injection of Ringer's solution into the anterior

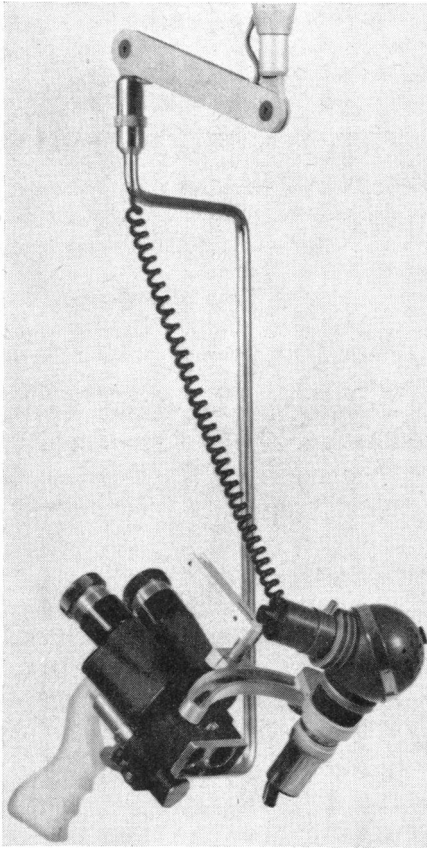

FIG. 5.—Independently suspended gonioscope may be released at any desired angle of observation. The position of the instrument is exactly retained.

chamber by a cannula. Depending on the exerted pressure, the angle not only opens but the iris becomes moulded against the lens and the zonular fibres, deepening the angle further (Fig. 3) by reducing the volume of the posterior chamber. Localized angle closure (synechiae) can be tested as to actual adherence by applying the mentioned stresses of corneal flattening and aqueous shift. If the angle opens, it is obvious that this is not a goniosynechia. Many apparently closed angles may be opened in this manner and open angles closed by edge pressure of the lens over Schwalbe's line. This may account for the common experience that apparent cases of closed-angle glaucoma still respond to miotic treatment. Those that do not open even slightly with fluid shift fail to respond and the choice of glaucoma surgery can be influenced by this finding.

In normal eyes the filling of the canal of Schlemm with blood by compression of the anterior emissary veins is frequently noticed, especially with the larger diameter lenses, but in cases of uncontrolled wide-angle glaucoma, this phenomenon is rarely obtained with this technique (Kronfeld, McGarry, and Smith, 1942; François, 1948; Smith, 1956).

It is hoped that careful measurement of the applied stresses will show differences in narrow angles and separate those that are prone to closure and those that are not. Measurement of stresses that lead to the filling of the canal of Schlemm with blood should also be attempted.

### Summary

Artefacts of the angle in gonioscopy are caused by mechanical distortion with the contact lens and optical distortion of the image. By changing the depth of angle with pressure, adherence of synechiae can be tested.

This project was supported by M.R.C. Grant MA-1558, Ottawa. Mr. G. Weiss of "Medical Instruments Sales and Service", Montreal, constructed the gonioscope-slit lamp to specifications.

### REFERENCES

- FRANÇOIS, J. (1948). "La gonioscopie", p. 218. Fonteyn, Louvain.  
 KRONFELD, P. C., MCGARRY, H. I., and SMITH, H. E. (1942). *Amer. J. Ophthalm.*, **25**, 1163.  
 SCHIRMER, K. E. (1964). *Arch. Ophthalm. (Chicago)*, **71**, 475.  
 ——— (1965). *Ibid.*, **74**, 465.  
 SMITH, R. (1956). *Brit. J. Ophthalm.*, **40**, 358.  
 WORST, J. G. F., and OTTER, K. (1961). *Amer. J. Ophthalm.*, **51**, 410.