

## Purification of the active C5a receptor from human polymorphonuclear leukocytes as a receptor-G<sub>i</sub> complex

(complement component C5/affinity chromatography/reversible modification/guanine nucleotide-binding protein)

THOMAS E. ROLLINS, SALVATORE SICILIANO, SUMIRE KOBAYASHI, DANA N. CIANCIARULO, VICTORIA BONILLA-ARGUDO, KENNETH COLLIER, AND MARTIN S. SPRINGER\*

Department of Immunology Research, Merck Sharp & Dohme Research Laboratories, Rahway, NJ 07065

Communicated by Edward M. Scolnick, November 14, 1990

**ABSTRACT** We have isolated, in an active state, the C5a receptor from human polymorphonuclear leukocytes. The purification was achieved in a single step using a C5a affinity column in which the C5a molecule was coupled to the resin through its N terminus. The purified receptor, like the crude solubilized molecule, exhibited a single class of high-affinity binding sites with a  $K_d$  of 30 pM. Further, the binding of C5a retained its sensitivity to guanine nucleotides, implying that the purified receptor contained a guanine nucleotide-binding protein (G protein). SDS/PAGE revealed the presence of three polypeptides with molecular masses of 42, 40, and 36 kDa, which were determined to be the C5a-binding subunit and the  $\alpha$  and  $\beta$  subunits of G<sub>i</sub>, respectively. The 36- and 40-kDa polypeptides were identified by immunoblotting and by the ability of pertussis toxin to ADP-ribosylate the 40-kDa molecule. These results confirm our earlier hypothesis that the receptor exists as a complex with a G protein in the presence or absence of C5a. The tight coupling between the receptor and G protein should make possible the identification of the G protein(s) involved in the transduction pathways used by C5a to produce its many biological effects.

C5a is a 74-amino acid glycopeptide generated by cleavage of complement component C5 upon activation of the complement system. The numerous responses elicited by the molecule imply that it is an important mediator of inflammatory processes (see refs. 1-3 for reviews). The peptide stimulates the contraction of smooth muscle, induces increases in vascular permeability, and promotes the synthesis and release of other mediators, including histamine, leukotrienes, and platelet activating factor. C5a is also a potent chemotaxin and secretagogue for phagocytic cells such as polymorphonuclear leukocytes (PMNs) and macrophages. The molecule activates the respiratory burst in these cells and alters their surface properties, leading to enhanced adhesion and aggregation.

These responses are triggered by the binding of C5a to a high-affinity receptor on the cell surface. As for other chemoattractants, such as the formyl peptides and leukotriene B<sub>4</sub>, the signal-transduction mechanism for C5a involves one or more pertussis toxin-sensitive guanine nucleotide-binding proteins (G proteins) (4-9). While the evidence for this coupling is compelling, the details of the interactions between the receptor and the G proteins are not understood, nor have the identities of the transducing G proteins been established. This latter question is of particular interest because of the number of responses initiated by C5a, and the disparity in their concentration dependencies.

The C5a receptor on PMNs has been identified by crosslinking <sup>125</sup>I-labeled C5a to intact cells and cell mem-

branes (10-12). The results imply that the receptor has a molecular mass of 40-50 kDa. In contrast, gel filtration experiments with active, detergent-solubilized receptor indicate that the functional molecule is substantially larger, suggesting that the receptor itself is oligomeric or is associated with another protein (13). Crosslinking studies with the solubilized receptor revealed the existence of 90-kDa species, as well as the previously reported smaller form, providing additional evidence supporting the latter conclusion (13). These data, as well as the GTP sensitivity of the solubilized receptor, led to the hypothesis that the C5a receptor consisted of 40- to 50-kDa binding subunit that was coupled, in the absence of ligand, to a G protein (13, 14).

In the present study we report the purification of the C5a receptor from human PMN membranes. The isolation was achieved in a single step using a C5a affinity column in which the ligand was attached to Affi-Gel 10 through its N terminus. The isolated protein consists of three polypeptide chains with molecular masses of 42, 40, and 36 kDa, which are the receptor proper and the  $\alpha$  and  $\beta$  subunits of the inhibitory G protein G<sub>i</sub>, respectively.

### MATERIALS AND METHODS

**Materials.** Na<sup>125</sup>I (carrier-free) and [<sup>32</sup>P]NAD were obtained from Amersham. Chloramine T and 3,4,5,6-tetrahydrophthalic anhydride were from Aldrich. Guanosine 5'-[ $\gamma$ -thio]triphosphate (GTP[ $\gamma$ S]) was purchased from Boehringer Mannheim, digitonin from Gallard Schlesinger, Affi-Gel 10 from Bio-Rad, and pertussis and cholera toxins from List Biological Laboratories (Campbell, CA). The polyclonal anti-G  $\alpha$ -subunit (GA/1) and G  $\beta$ -subunit (MS/1) antibodies were from NEN, the biotinylated goat anti-rabbit antibody from Pierce, and the phosphatase-labeled streptavidin from KPL Laboratories (Gaithersburg, MD). Purified G<sub>i</sub>/G<sub>o</sub> from bovine brain, was the gift of M. Graziano (Merck Sharp & Dohme). The leukocyte concentrates were obtained from the New York Blood Center. Natural human C5a was purified and iodinated to a specific activity of 200  $\mu$ Ci/ $\mu$ g (1  $\mu$ Ci = 37 kBq) according to Rollins *et al.* (13). Membranes from human PMNs were prepared as described (13). Recombinant C5a was generated and isolated as described by Bonilla-Argudo *et al.* (15).

**Solubilization of Membranes.** One volume of membrane suspension (protein concentration, 2-3 mg/ml) was added to 1 volume of 50 mM Hepes, pH 7.2, containing 2% (wt/vol) digitonin, 0.1 mM phenylmethylsulfonyl fluoride, and aprotinin, chymostatin, and leupeptin at 10  $\mu$ g/ml each, mixed for 10 sec, and then incubated for 60 min on ice. The insoluble material was removed by centrifugation for 7 min at 200,000

The publication costs of this article were defrayed in part by page charge payment. This article must therefore be hereby marked "advertisement" in accordance with 18 U.S.C. §1734 solely to indicate this fact.

Abbreviations: PMN, polymorphonuclear leukocyte; GTP[ $\gamma$ S], guanosine 5'-[ $\gamma$ -thio]triphosphate; G protein, guanine nucleotide-binding protein.

\*To whom reprint requests should be addressed.

$\times g$  in a Beckman TL-100 centrifuge. The solubilized extract, which is stable for >24 hr, was stored on ice until use.

**Binding Assays.** Assay buffer (50 mM Hepes, pH 7.2/1 mM  $\text{CaCl}_2$ /5 mM  $\text{MgCl}_2$ /0.5% bovine serum albumin with the protease inhibitors aprotinin, chymostatin, leupeptin, and phenylmethylsulfonyl fluoride as described above),  $^{125}\text{I}$ -C5a (typically 20 pM), the desired concentration of unlabeled C5a, and solubilized receptor were added sequentially to a polypropylene tube to a final volume of 250  $\mu\text{l}$ . After 40 min of incubation, 1 ml of 0.1 M Hepes, pH 7.2/9.6% (wt/vol) polyethylene glycol 8000 was added; the solution was mixed and, after an additional 5 min, filtered over a Whatman GF/C membrane previously soaked in 0.33% polyethylenimine. Another 2 ml of buffer was added to the tube and used to wash the filter. Nonspecific backgrounds were determined by inclusion of a 100-fold excess of unlabeled C5a. Unless otherwise stated all procedures were performed at 0°C. In experiments designed to test the effects of GTP[ $\gamma\text{S}$ ], the solubilized receptor was preincubated with the nucleotide for 30 min at 22°C (14). Natural human C5a was used in all of the binding assays.

**Preparation of the C5a Affinity Resin.** One hundred twenty microliters of tetrahydrophthalic anhydride (3.65 mg/ml in dioxane) was added to 12 ml of recombinant C5a (1 mg/ml in 0.1 M Hepes, pH 8.0) and incubated for 5 hr at room temperature. This procedure resulted in the acylation of 15% of the amino groups on the molecule. At this time 86  $\mu\text{l}$  of maleic anhydride (78.4 mg/ml in dioxane) was added and the incubation was continued overnight to derivatize the remainder of the amino groups. The pH was then adjusted to 5.7, and the sample was incubated overnight to remove the tetrahydrophthaloyl groups. The sample was titrated to pH 8, dialyzed against 0.1 M Hepes, pH 8, and concentrated using an Amicon YM5 membrane to achieve a C5a concentration of 4 mg/ml. The 3 ml of derivatized C5a was added to 2 ml of Affi-Gel 10 and incubated overnight on a rotator at 4°C. The gel was washed with 0.1 M Hepes, pH 8, and the unreacted ester groups were blocked by the addition of 1 M glycine. After an additional 4 hr of incubation the gel was washed twice with 0.1 M Hepes, pH 3.2, and incubated for 72 hr at 37°C to remove the maleoyl groups. The resin was washed and stored in 50 mM Hepes, pH 7.2.

**Affinity Chromatography.** The affinity resin was washed and equilibrated with buffer A (0.2 M Hepes, pH 7.2/0.1% digitonin/5 mM  $\text{MgCl}_2$ ). The solubilized membrane was batch-absorbed by incubation with the affinity resin for 48 hr on a rotator. The mixture was poured into a 1  $\times$  15-cm column and the resin was washed sequentially with 40 ml of buffer A, 90 ml of buffer B (0.1 M Hepes, pH 7.2/0.1% digitonin/5 mM  $\text{MgCl}_2$ /1 M NaCl), and 13 ml of buffer C (0.1 M Hepes, pH 7.2/0.1% digitonin). The receptor was eluted with buffer D (50 mM formic acid, pH 4.0/0.2 M KSCN/0.1% digitonin). The fractions containing the receptor were immediately desalted on a 10-ml Bio-Rad P-10 column using 0.1 M Hepes, pH 7.2/0.1% digitonin/5 mM  $\text{MgCl}_2$ .

**ADP-Ribosylation.** Pertussis toxin was activated as described by Nomura *et al.* (16). Ribosylations were performed by adding 35  $\mu\text{l}$  of purified receptor, 50  $\mu\text{l}$  of activated pertussis toxin, 320  $\mu\text{l}$  of 50 mM Tris Cl, pH 7.4/5 mM  $\text{MgCl}_2$ /2 mM EDTA/10 mM thymidine to tubes together with 10  $\mu\text{l}$  of 50  $\mu\text{M}$  ATP and 10  $\mu\text{l}$  of [ $^{32}\text{P}$ ]NAD (500  $\mu\text{M}$ , 1 Ci/mmol). The tubes were mixed with a Vortex and incubated for 20 min at 22°C, at which time additional 10- $\mu\text{l}$  aliquots of ATP and NAD were added and the incubations were continued for another 20 min. The samples were ethanol-precipitated and subjected to SDS/PAGE (17). Controls for the pertussis toxin specificity of the ribosylation were performed as described above except that activation buffer without toxin was substituted for the activated pertussis toxin in the incubations.

**Electrophoresis and Immunoblotting.** After SDS/PAGE the purified receptor was electrophoretically transferred to nitrocellulose and the free binding sites on the paper were blocked with 5% milk. The blots were sequentially probed with the common anti-G  $\beta$ -subunit antibody MS/1, and then with the common anti-G  $\alpha$ -subunit antibody GA/1. Visualization was carried out after each probe by treating the blots with a biotinylated goat anti-rabbit antibody, followed by phosphatase-labeled streptavidin.

## RESULTS

**Construction of a C5a Affinity Resin.** Our initial attempts to prepare a functional resin by using a variety of commercially available matrices and linkage chemistries were, in large measure, unsuccessful. The one exception was the coupling of C5a through its primary amino groups to the *N*-hydroxy-succinimide ester moieties of Affi-Gel 10. Unfortunately, these columns were extremely inefficient, could not be reproducibly prepared, and were unsuitable for the isolation of the needed quantities of receptor. Given the very high density of ester groups on Affi-Gel 10, and the presence of nine amino groups on C5a, we suspected that nearly all of the attached molecules were linked at multiple sites to the column, rendering them incapable of binding receptor, and that the very limited activity of the columns was due to a small number of molecules singly linked in the correct orientation. Since experiments designed to lower the density of ester groups on Affi-Gel 10 by prereacting the resin with primary amines were unsuccessful, we turned to the alternative strategy of using a reversible blocking agent to derivatize all but one of the amino groups on C5a prior to coupling the protein to the matrix.

Maleic anhydride and analogs react with primary amines to form amides which, while stable at basic and neutral pH, readily decompose at acidic pH to regenerate the original amino groups (18, 19). Moreover, the kinetics and pH dependence of the decomposition are highly dependent on the structure of the anhydride employed, a property we have exploited in preparing the affinity column. Our experience with C5a has been that the only amino group through which it can be coupled and retain activity is the N terminus. Since

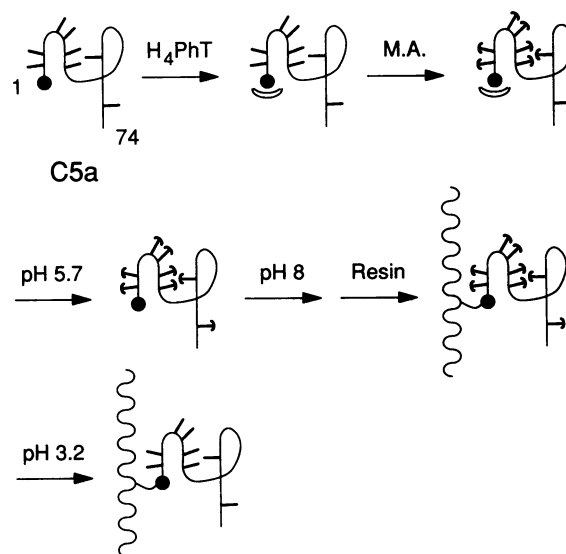

FIG. 1. Preparation of the C5a affinity resin. The single uncapped lines represent unblocked  $\epsilon$ -amino groups. The black circle represents the  $\alpha$ -amino group at the N terminus. M.A., maleic anhydride;  $\text{H}_4\text{PhT}$ , 3,4,5,6-tetrahydrophthalic anhydride. For details see *Materials and Methods*.

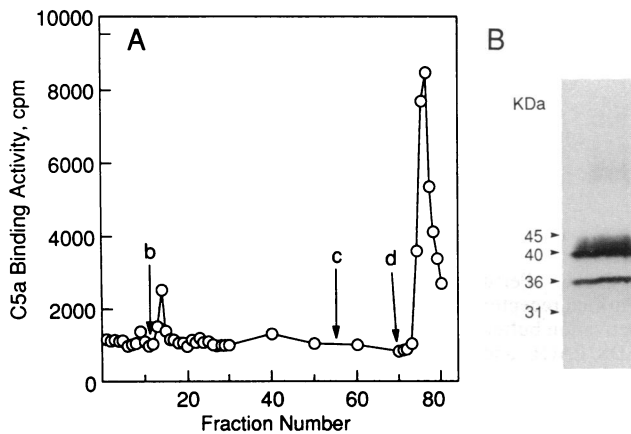

FIG. 2. Affinity purification of the C5a receptor. Six milliliters of PMN membrane (from  $6 \times 10^9$  cells) was solubilized and incubated with 2 ml of affinity resin for 48 hr and the chromatography was performed as described in *Materials and Methods*. (A) Aliquots of each fraction were assayed for their ability to bind  $^{125}\text{I}$ -C5a. Arrows b, c, and d indicate the times at which buffers B, C, and D were introduced to the column. Fraction sizes: 1–10, 4 ml; 11–55, 2 ml; 56–80, 1 ml. (B) Fractions 74–79 were pooled and desalted, and one-sixth of the material was subjected to SDS/10% PAGE. Protein was visualized with a silver stain.

the pK of the  $\alpha$ -amino group of the N terminus is lower than that of the  $\epsilon$ -amino group of lysine, simply reacting C5a with an anhydride will preferentially derivatize the N terminus and prevent coupling to the resin through the desired group. To circumvent this difficulty, and to create a derivative of C5a in which the N terminus is free and the lysine residues are blocked we have employed the paradigm shown in Fig. 1. C5a is reacted with enough tetrahydrophthalic anhydride (20, 21) to derivatize 1.5 mol of amino groups per mol of protein, effectively blocking the N terminus. Sufficient maleic anhydride is now added to derivatize the remainder of the amino groups. The tetrahydrophthaloyl groups are removed using conditions that will not result in removal of the maleoyl groups, producing a derivative that has a free N terminus. The modified C5a is then coupled to Affi-Gel 10 through the free N terminus, and the maleoyl groups are removed.

**Affinity Chromatography.** Preliminary experiments indicated that a lengthy incubation was necessary to efficiently adsorb the receptor to the affinity resin, a procedure most conveniently performed in a batch mode. After incubation for 48 hr, a small column was poured, the resin was subjected to a high-salt wash, and the receptor was eluted with a mildly acidic buffer containing a chaotrope (Fig. 2A). Since the receptor is unstable in the elution buffer, the fractions that contained the C5a binding activity, as determined in a prior

experiment, were pooled and chromatographed over a small desalting column without waiting for the results of the activity measurements. The recovery of C5a binding activity for the experiment shown in Fig. 2A was 84% and represents 3000 receptors per cell (membrane from  $6 \times 10^9$  cells was used in the experiment). Since the efficiency of the solubilization step is 30–35% (13), this number is equivalent to 10,000 receptors per cell in intact membranes and is similar to the 10,000–20,000 receptors per cell we typically find in whole PMNs. Over the course of many experiments the yield of binding activity from the affinity column has varied from 30% to 90%.

The pooled and desalted fractions contained three polypeptides, two of which migrated during SDS/PAGE as sharply defined bands with molecular masses of 36 and 40 kDa, and a third which migrated as a broad and somewhat indistinct band with an average molecular mass of 42 kDa (Fig. 2B). While the nearly 1:1:1 ratio of the three proteins shown in Fig. 2 was typical, some variation in the relative quantity of the 36-kDa protein has been observed (for example, see Fig. 6).

To explore whether all three polypeptides bind to the column through specific interactions with C5a, solubilized membrane was incubated with a saturating concentration of C5a prior to addition to the affinity resin. Such preincubation should block the adherence of any protein that binds specifically to C5a, but should have no effect on proteins that adhere to the column by means of nonspecific interactions. No C5a binding activity was eluted from the column when the extract was pretreated with C5a (Fig. 3A), demonstrating that under these conditions, the C5a receptor does not bind to the resin. The SDS/PAGE profile for the control sample, which was not preincubated with C5a (Fig. 3B, lane 1) is similar to that observed in Fig. 2, except for the presence of a 44-kDa band, which was not visible in the previous experiment (this additional band has been observed in about half of the chromatography experiments). Preincubation with C5a resulted in the disappearance of the 36-, 40-, and 42-kDa polypeptides, demonstrating that all three bind specifically to the column. In contrast, the 44-kDa band binds nonspecifically to the column, since its presence was not affected by preincubation with C5a. The 36-, 40-, and 42-kDa polypeptides appear to form part of a single complex, since they are not separated, nor is their stoichiometry altered, by anion-exchange chromatography following elution from the affinity column (data not shown).

**Binding Properties of the Purified Receptor.** The equilibrium binding properties of the receptor, in both its unfractionated and purified states, were determined from competition experiments. As described previously (13, 14), the crude solubilized receptor exhibits a single class of high-affinity binding sites that have a  $K_d$  for C5a of 30 pM (Fig. 4).

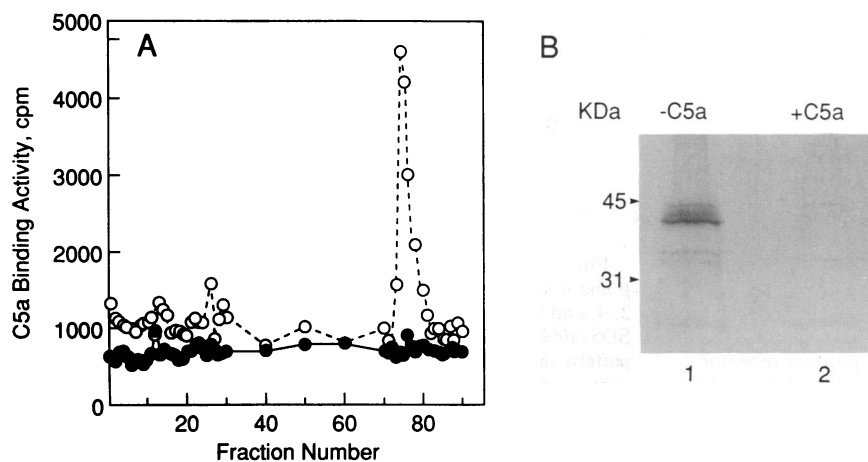

FIG. 3. Effect of preincubation with C5a on the affinity purification of the C5a receptor. Eight milliliters of PMN membrane was solubilized in digitonin and divided into two aliquots. One aliquot was incubated with 50  $\mu\text{M}$  C5a for 30 min before addition to the affinity resin, while the second aliquot was preincubated with buffer. Affinity chromatography was performed as described in Fig. 2. (A) Activity profiles for the samples preincubated with C5a (●) or buffer (○). (B) Fractions 74–82 of each chromatogram were pooled, desalted, and subjected to SDS/10% PAGE. Protein was visualized with a silver stain. Lane 1, preincubated without C5a; lane 2, preincubated with C5a.

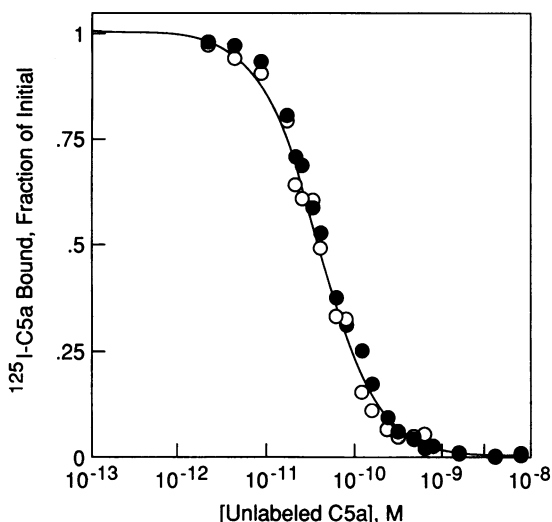

FIG. 4. Equilibrium binding properties of crude soluble receptor (○) and the purified receptor (●). These assays were carried out by adding various concentrations of unlabeled C5a to a constant amount of  $^{125}\text{I}$ -C5a. Nonspecific backgrounds of 710 cpm have been subtracted from both curves. The total  $^{125}\text{I}$ -C5a added and bound were 12,400 and 2979 cpm for the purified receptor and 12,400 and 2854 cpm for the crude solubilized receptor. All values are averages of duplicate determinations. This experiment has been replicated three times with similar results.

The binding curve for the purified receptor is indistinguishable from that of the unfractionated receptor (Fig. 4), demonstrating that the isolated molecule contains all of the components necessary to form the high-affinity state. Since we have previously shown that the high-affinity state of the receptor requires the presence of a G protein (14), the active species isolated from the affinity column should, minimally, consist of the binding subunit of the receptor and a G protein. This conclusion is supported by the observation that the GTP analog GTP[ $\gamma$ S] inhibits C5a binding to the purified receptor (Fig. 5). Further, the molecular masses of the 40- and 36-kDa polypeptides are identical with those of the  $\alpha$  and  $\beta$  subunits of  $G_{12}$ , the major pertussis toxin substrate of the PMN (22, 23).

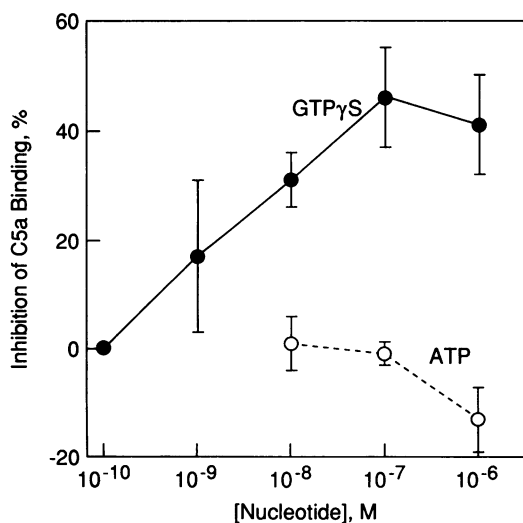

FIG. 5. GTP[ $\gamma$ S] inhibits C5a binding to the purified receptor. The receptor was preincubated with either GTP[ $\gamma$ S] or ATP at the indicated concentrations, and the binding assays were performed as described in *Materials and Methods*. These data show the results of one of three similar experiments.

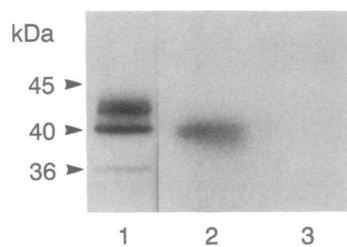

FIG. 6. Pertussis toxin ADP-ribosylates the 40-kDa polypeptide. Purified receptor was treated with pertussis toxin or pertussis toxin activation buffer in the presence of  $^{32}\text{P}$ NAD and then subjected to SDS/PAGE and autoradiography. Lane 1, silver-stain pattern of untreated receptor; lane 2, autoradiograph of pertussis toxin-treated receptor; lane 3, autoradiograph of receptor treated with pertussis toxin activation buffer without toxin.

**Identification of the 40- and 36-kDa Polypeptides as the  $\alpha$  and  $\beta$  Subunits of  $G_i$ .** If the 40-kDa polypeptide is the  $\alpha$  subunit of a  $G_i$  protein, then treatment with pertussis toxin should result in its ADP-ribosylation. Accordingly, the affinity-purified receptor was divided into aliquots, which were incubated with  $^{32}\text{P}$ NAD in the presence or absence of pertussis toxin and then subjected to SDS/PAGE. The protein pattern again revealed three bands at 36, 40, and 42 kDa (Fig. 6, lane 1). The 40-kDa polypeptide was ADP-ribosylated by pertussis toxin (lanes 2 and 3), providing direct evidence that this polypeptide is the  $\alpha$  subunit of  $G_i$ .

To establish the identity of the 36-kDa polypeptide, we examined the ability of MS/1, a rabbit polyclonal antibody raised against the N terminus of the G-protein  $\beta$  subunit, to interact with this protein. As shown in a Western blot of the purified receptor, the antibody specifically recognized the 36-kDa polypeptide (Fig. 7A), demonstrating that it is the  $\beta$  subunit of a G protein. The same blot was then re-probed with GA/1, an antibody to the GTP binding site on the  $\alpha$  subunit. This antibody specifically bound to the 40-kDa polypeptide (Fig. 7B), providing confirmatory evidence that it is a G-protein  $\alpha$  subunit.

## DISCUSSION

In this communication we report the purification of the C5a receptor from human PMN membranes by means of affinity chromatography. The protein isolated by this procedure is a noncovalent complex of three polypeptides with molecular masses of 42, 40, and 36 kDa, which represent the binding subunit of the receptor and the  $\alpha$  and  $\beta$  subunits of a G

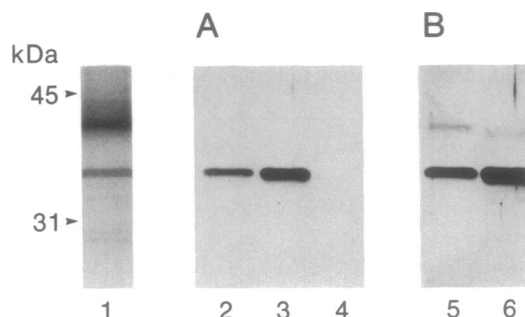

FIG. 7. Identification of the 36- and 40-kDa polypeptides as the  $\beta$  and  $\alpha$  subunits of a G protein. Affinity-purified receptor (lanes 1, 2, 4, and 5) and purified G protein (lanes 3 and 6) were subjected to SDS/10% PAGE gels and immunoblotting. Lane 1, silver-stain pattern of purified receptor. (A) Immunoblot probed with anti- $\beta$ -subunit antibody MS/1. Lane 2, purified receptor; lane 3, purified G protein; lane 4, irrelevant rabbit polyclonal antibody probe of purified receptor. (B) Re-probe of the blot in A with the anti- $\alpha$ -subunit antibody GA/1. Lane 5, purified receptor; lane 6, purified G protein.

protein, respectively. The identifications of the latter two polypeptides as G-protein subunits are based on five lines of evidence. (i) The affinity of the purified receptor for C5a is identical to that found in detergent extracts of PMN membranes. Since we have shown (14) that the high-affinity state of the receptor requires the presence of a G protein, the purified receptor must contain one. (ii) GTP[ $\gamma$ S] inhibits the binding of C5a to the purified receptor. The negative heterotropic effect of guanine nucleotides on ligand binding is one of the distinguishing characteristics of a G-protein-receptor complex (24). (iii) Pertussis toxin catalyzes the ADP-ribosylation of the  $\alpha$  subunit of G<sub>i</sub> (24), and, as shown in Fig. 6, the toxin causes the ADP-ribosylation of the 40-kDa polypeptide. (iv) Specific anti- $\alpha$ - and anti- $\beta$ -subunit antibodies react with the 40- and 36-kDa polypeptides, respectively. (v) The molecular masses of the 40- and 36-kDa polypeptides are identical to those of the  $\alpha$  and  $\beta$  subunits of G<sub>i2</sub>, which is the major pertussis toxin substrate in PMNs.

The 42-kDa polypeptide is the C5a receptor itself. This result verifies earlier crosslinking studies which implied that the binding subunit of the receptor has a molecular mass of 40–50 kDa (10–12). Moreover, the 42-kDa polypeptide migrates as a rather diffuse band on SDS/PAGE, a property often associated with glycoproteins. Like many other cell surface receptors, the C5a receptor is glycosylated as shown by its strong adherence to a variety of lectins (unpublished observations).

We previously concluded from gel filtration and crosslinking studies that the detergent-solubilized, unliganded, C5a receptor exists largely as a heterooligomer that contains the binding subunit of the receptor complexed to another protein (13). We further speculated that the additional component was a G protein. However, this latter hypothesis rested on the assumption that the liganded receptor was itself physically coupled to a G protein. Since agonists are known to promote the association of receptors with G proteins (24), this assumption was plausible, although not supported by direct evidence. The results in the present communication provide that direct evidence and demonstrate that the C5a receptor is coupled to its G protein(s) in the presence or absence of C5a.

Which G protein(s) interact with the receptor and therefore mediate the numerous responses elicited by C5a? Many G proteins have been identified by molecular cloning, with dozens of potential  $\alpha\beta\gamma$  combinations (see ref. 25 for a review). Until now, reconstitution studies have been the primary experimental approach to identifying the G protein that acts as the transducer in a particular system. However, interpretations of the results of these studies have been complicated by the apparent promiscuity of the receptor-G-protein interactions and by the logistical problems of trying more than a few of the possible combinations. The tight coupling between the C5a receptor and its G protein(s) provides an avenue to directly identify the transducing G

protein(s). Finally, the ability to isolate the C5a receptor should allow detailed molecular studies of the receptor itself.

We thank Alan Powell for his help in preparing the recombinant C5a and Dr. M. Graziano for his gift of purified G<sub>i</sub>/G<sub>o</sub>. We are grateful to Dr. N. Sigal for his support and for comments on the manuscript and to Drs. C. Strader, L. Peterson, and P. Davies for critical reading of the manuscript.

- Hugli, T. E. (1981) *Crit. Rev. Immunol.* **1**, 321–366.
- Hugli, T. E. (1984) *Springer Semin. Immunopathol.* **7**, 193–219.
- Goldstein, I. M. (1988) in *Inflammation: Basic Principles and Clinical Correlates*, eds. Gallin, J. I., Goldstein, I. M. & Snyderman, R. (Raven, New York), pp. 55–74.
- Becker, E. L., Kermude, J. L., Naccache, P. H., Yassin, R., Marsh, M. L., Munoz, I. J. & Sha'afi, R. I. (1985) *J. Cell Biol.* **100**, 1640–1646.
- Goldman, D. W., Chang, F.-H., Gifford, L. A., Goetzl, E. J. & Bourne, H. R. (1985) *J. Exp. Med.* **162**, 145–156.
- Lad, P. M., Olson, C. V. & Smiley, P. A. (1985) *Proc. Natl. Acad. Sci. USA* **82**, 869–873.
- Shirato, M., Takahashi, K., Nagasawa, S. & Koyama, J. (1988) *FEBS Lett.* **234**, 231–234.
- Feltner, D. E., Smith, R. H. & Marasco, W. A. (1986) *J. Immunol.* **137**, 1961–1970.
- Wilde, M. W., Carlson, K. E., Manning, D. R. & Zigmond, S. H. (1988) *J. Biol. Chem.* **264**, 190–196.
- Rollins, T. E. & Springer, M. S. (1985) *J. Biol. Chem.* **260**, 7157–7160.
- Johnson, R. J. & Chenoweth, D. E. (1985) *J. Biol. Chem.* **260**, 7161–7164.
- Huey, R. & Hugli, T. E. (1985) *J. Immunol.* **135**, 2063–2068.
- Rollins, T. E., Siciliano, S. J. & Springer, M. S. (1988) *J. Biol. Chem.* **264**, 520–526.
- Siciliano, S. J., Rollins, T. E. & Springer, M. S. (1990) *J. Biol. Chem.* **265**, 19568–19574.
- Bonilla-Argudo, V., Fieldhouse, J., Gimenez-Gallego, G., Springer, M. S. & Collier, K. (1987) *Fed. Proc. Fed. Am. Soc. Exp. Biol.* **46**, 786.
- Nomura, Y., Kitamura, Y. & Segawa, T. (1985) *J. Neurochem.* **44**, 364–369.
- Laemmli, U. K. (1970) *Nature (London)* **227**, 680–685.
- Leach, S. J. & Lindley, H. (1953) *Trans. Faraday Soc.* **49**, 915–920.
- Butler, P. J. G., Harris, J. I., Hartley, B. S. & Liberman, R. (1969) *Biochem. J.* **112**, 679–689.
- Kirby, A. J. & Lancaster, P. W. (1972) *J. Chem. Soc. Perkin Trans. 2*, 1206–1214.
- Gibbons, I. & Schachman, H. K. (1976) *Biochemistry* **15**, 52–60.
- Gierschik, P., Fallon, J., Milligan, G., Pines, M., Gallin, J. I. & Spiegel, A. (1986) *J. Biol. Chem.* **261**, 8058–8062.
- Goldsmith, P., Gierschik, P., Milligan, G., Unson, C. G., Vinitzky, R., Malech, H. L. & Spiegel, A. (1987) *J. Biol. Chem.* **262**, 14683–14688.
- Gilman, A. G. (1987) *Annu. Rev. Biochem.* **56**, 615–649.
- Kaziro, Y., Itoh, H., Kozaso, R., Toyma, R., Tsukamoto, T., Matsuoka, M., Nakafuku, M., Obara, T., Takagi, T. & Hernandez, R. (1988) *Cold Spring Harbor Symp. Quant. Biol.* **53**, 209–220.