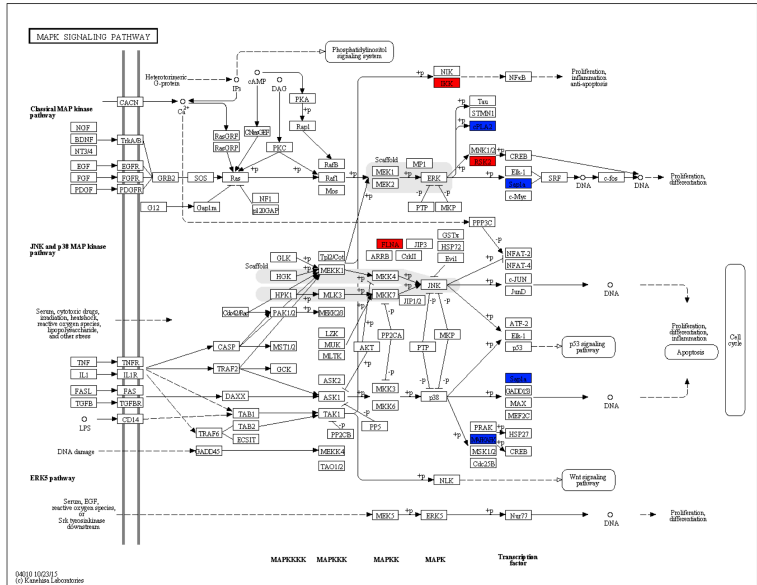

Figure S1

MAPK signaling pathway (map04010)

IH5D



IH28D

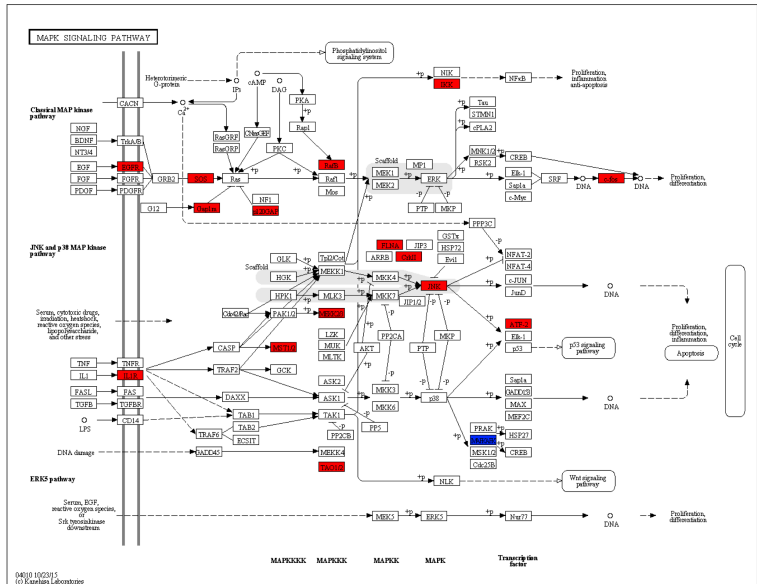

12m

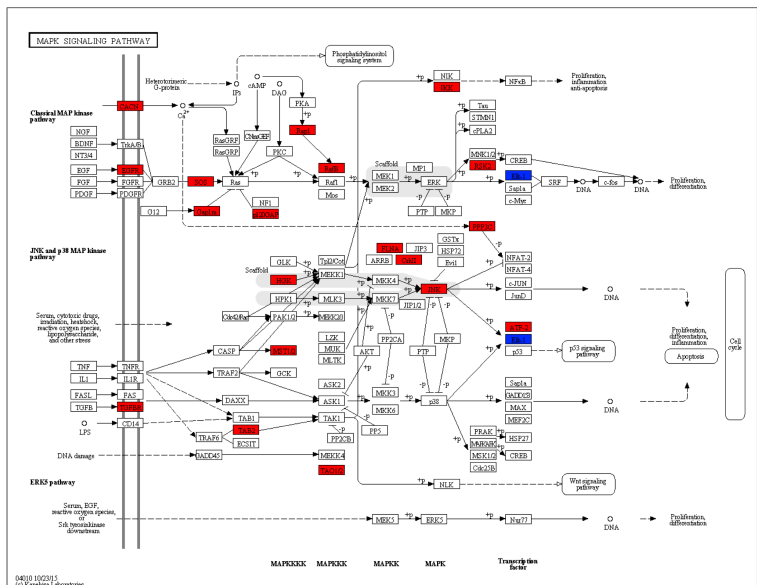
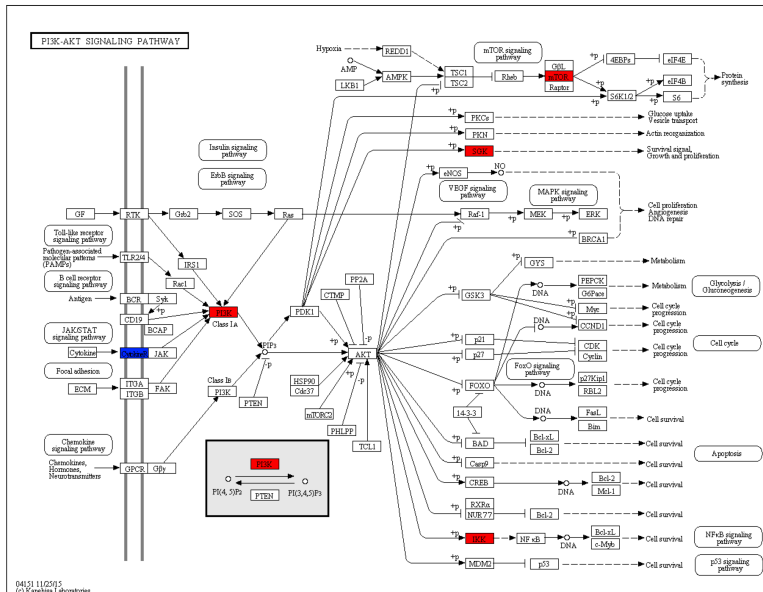

Figure S2

PI3K-Akt signaling pathway (map04151)

IH5D



IH28D

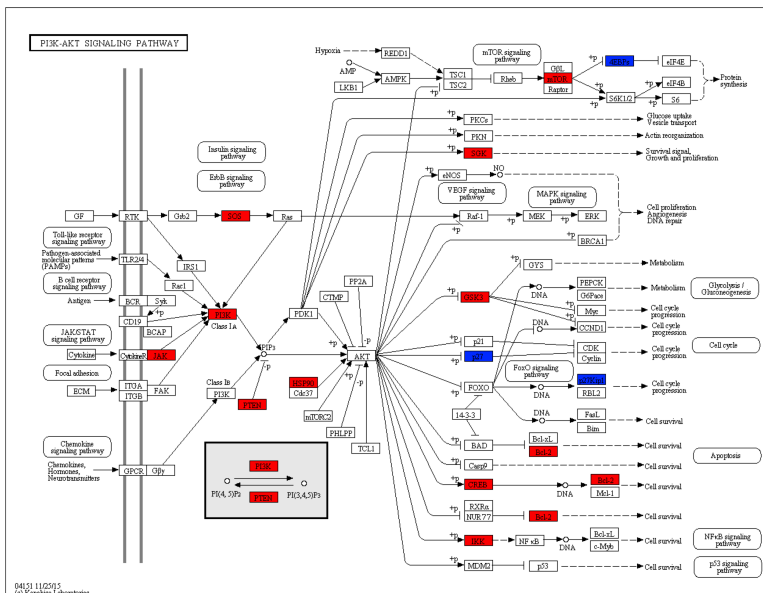

12m

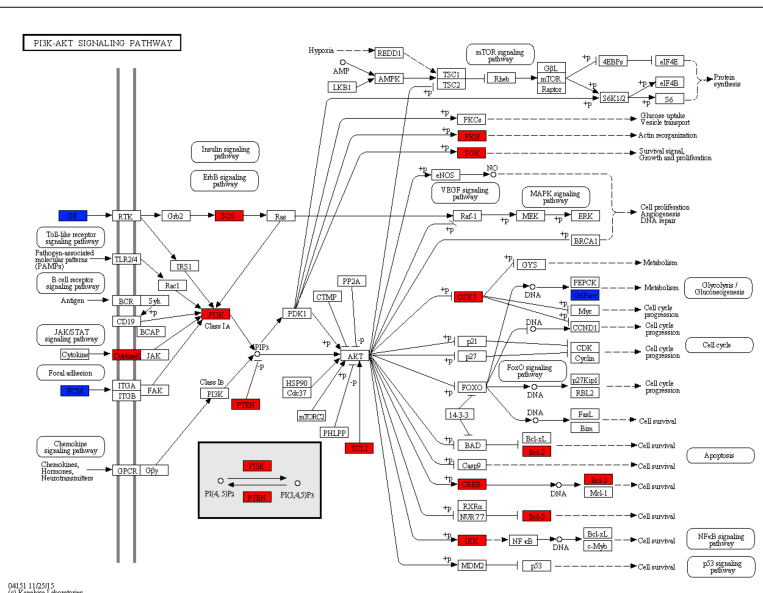

Figure S3

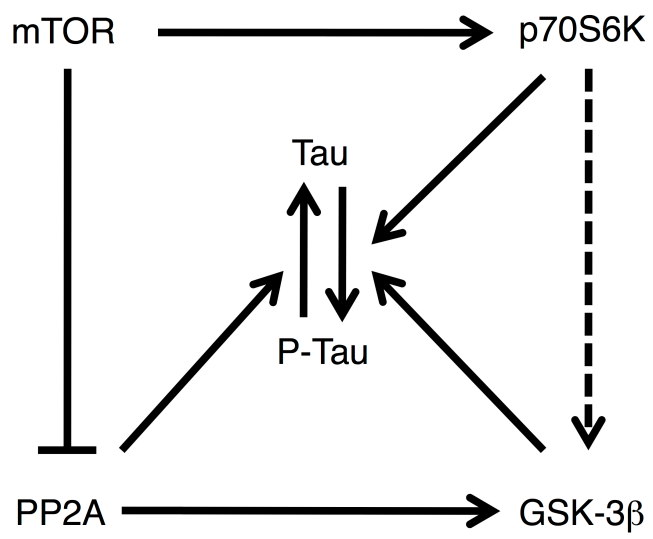
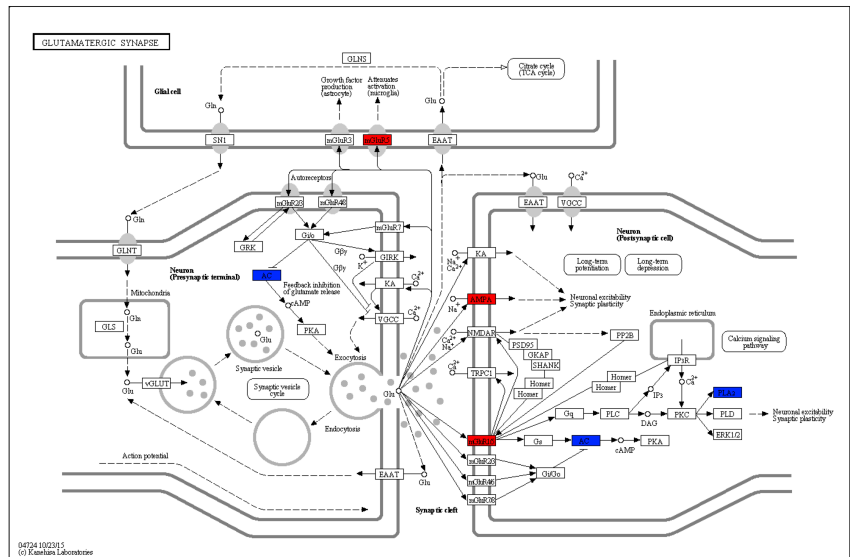

Figure S4

Glutamatergic Synapse (map04724)

IH5D



IH28D

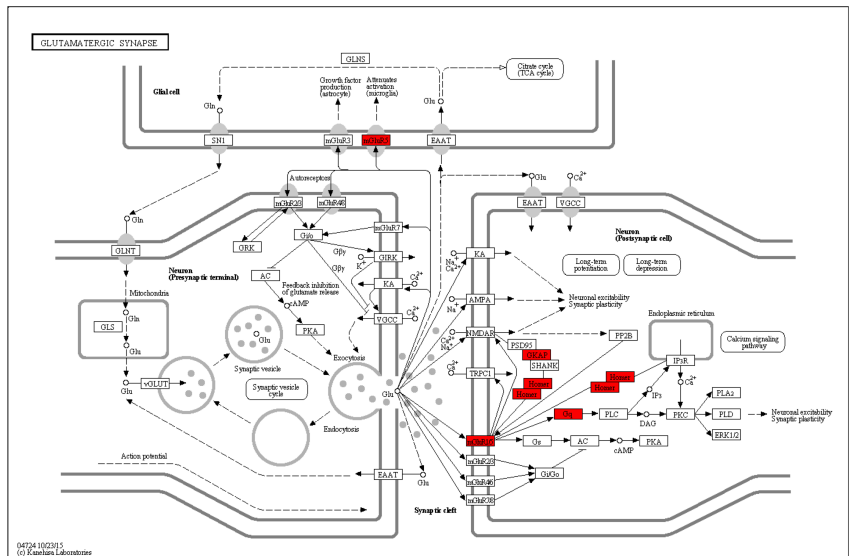

12m

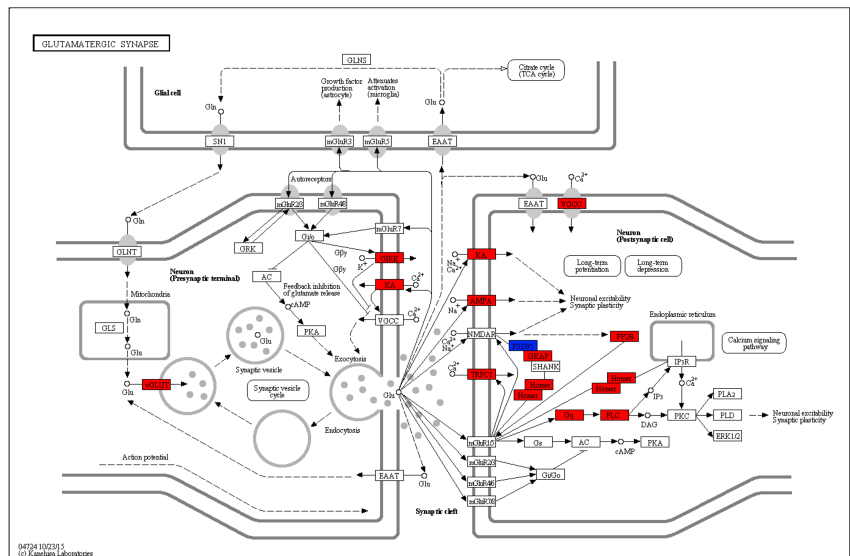

Figure S5