

Direction of transneuronal transport of herpes simplex virus 1 in the primate motor system is strain-dependent

(motor cortex/basal ganglia/cerebellum/axonal transport/*Cebus apella*)

MARK C. ZEMANICK*, PETER L. STRICK*[†], AND RICHARD D. DIX[‡]

*Research Service (151), Veterans Administration Medical Center, Departments of Neurosurgery and Physiology, State University of New York Health Science Center, Syracuse, NY 13210; and [‡]Departments of Ophthalmology, Microbiology and Immunology, and Neurology, University of Miami School of Medicine, Bascom Palmer Eye Institute, Miami, FL 33101

Communicated by Ann M. Graybiel, June 14, 1991 (received for review March 26, 1991)

ABSTRACT We examined the axonal transport of two strains of herpes simplex virus 1 (HSV-1) within the central nervous system of cebus monkeys. Each strain was injected into the “arm area” of the primary motor cortex. One strain, HSV-1(McIntyre-B), was transported transneuronally in the retrograde direction. It infected neurons at sites known to project to the arm area of the primary motor cortex (e.g., ventrolateral thalamus). In addition, “second-order” neurons were labeled in the deep cerebellar nuclei (dentate and interpositus) and in the globus pallidus (internal segment). This result supports the concept that the arm area of the primary motor cortex is a target of both cerebellar and basal ganglia output. In contrast, the other strain, HSV-1(H129), was transported transneuronally in the anterograde direction. It infected neurons at sites known to receive input from the arm area of the primary motor cortex (e.g., putamen, pontine nuclei). In addition, “third-order” neurons were labeled in the cerebellar cortex (granule and Golgi cells) and in the globus pallidus (largely the external segment). Our observations suggest that strain differences have an important impact on the direction of transneuronal transport of HSV-1. Furthermore, it should be possible to examine the organization of cerebellar and basal ganglia loops with cerebral cortex by exploiting transneuronal transport of HSV-1 and virus strain differences.

Part of the neural substrate for the central control of movement in primates is formed by multiple “loops” between the cerebral cortex and two subcortical centers, the basal ganglia and the cerebellum. These circuits are thought to be involved in many aspects of motor behavior, including the programming, initiation, and regulation of limb movement (e.g., refs. 1–4). In recent experiments, we have begun to explore the structure of these loops by using transneuronal transport of herpes simplex virus 1 (HSV-1). In the course of these studies, we made the surprising observation that the direction of transneuronal transport within these circuits depends on the specific strain of HSV-1 inoculated into the animal. To illustrate this result, in this report we describe some of the patterns of transneuronal transport of two strains of HSV-1 within the pathways that link the “arm area” of the primary motor cortex with the basal ganglia and cerebellum.

MATERIALS AND METHODS

Either the H129 strain (5) (1.5×10^{12} plaque-forming units (pfu)/ml, $n = 2$; 8.0×10^{10} pfu/ml, $n = 1$) or the McIntyre-B strain (6) (6.1×10^8 pfu/ml, $n = 2$) of HSV-1 was injected into the left arm area of the primary motor cortex (7) of cebus monkeys (*Cebus apella*). Each animal was anesthetized with ketamine (10 mg/kg, i.m.) and Nembutal (sodium pentobar-

bital, 25 mg/kg, i.p.), and 0.05 μ l of virus was injected at each of six cortical sites. The surgical procedures used have been described in detail (8, 9). The injection sites included both the crest of the precentral gyrus and the anterior bank of the central sulcus. Two to three days after inoculation, animals demonstrated motor symptoms of infection (i.e., myoclonic jerks involving the hand, arm, and shoulder contralateral to the injection site). Approximately 4 days after inoculation, animals were deeply anesthetized and perfused transcardially with 0.1 M phosphate buffer (pH 7.4), followed by 4% (wt/vol) paraformaldehyde in 0.1 M phosphate buffer and 4% paraformaldehyde in 0.1 M phosphate buffer with 10% (vol/vol) glycerol. Serial coronal sections through the brain and spinal cord were cut at 50 μ m with a freezing microtome. Free-floating tissue sections were reacted immunohistochemically to demonstrate the presence of virus-specific antigens (10, 11) by the avidin-biotin-peroxidase method (ABC, Vectastain; Vector). Immunoreactivity was developed by incubation in a solution prepared by mixing equal volumes of 0.1% 3,3'-diaminobenzidine tetrahydrochloride and 0.02% hydrogen peroxide. At least every fourth section was treated in this manner.

The procedures and care provided experimental animals conformed to the regulations detailed in the *National Institutes of Health Guide for the Care and Use of Laboratory Animals*. All experimental protocols were reviewed and approved by the appropriate institutional Animal Care and Use Committees. In addition, the conduct of our experiments conformed to BSL-2+ regulations detailed in Health and Human Services Publication 88-8395 (*Biosafety in Microbiological and Biomedical Laboratories*).

RESULTS

Regions of the primary motor cortex that surrounded each of the virus injection sites were completely filled with virus-specific antigen. Since multiple injection sites were placed in each animal, it was difficult to determine the exact amount of spread from any single site. However, virus-specific antigen was present at injection sites in the arm area of the primary motor cortex (i.e., on the crest of the precentral gyrus and in the anterior bank of the central sulcus) and did not spread into the adjacent face or leg representation. No differences were observed in the extent of spread of the two strains of HSV-1 from their injection sites.

After injections of HSV-1(McIntyre-B), densely labeled neurons were found in all the cortical and subcortical regions known to project to the arm area of the primary motor cortex (e.g., refs. 8, 9, 12–18). For example, the two subdivisions of the ventrolateral thalamus that innervate the primary motor cortex—

The publication costs of this article were defrayed in part by page charge payment. This article must therefore be hereby marked “advertisement” in accordance with 18 U.S.C. §1734 solely to indicate this fact.

Abbreviations: HSV-1, herpes simplex virus 1; VLo, ventralis lateralis pars oralis; VPLO, ventralis posterior lateralis pars oralis.
[†]To whom reprint requests should be addressed.

ventralis lateralis pars oralis (VLo) and ventralis posterior lateralis pars oralis (VPLo)—contained large numbers of labeled neurons (Fig. 1A). In contrast, those subcortical regions known to receive input from, but not project to, the primary motor cortex (e.g., putamen, red nucleus, pontine nuclei, spinal cord) did not contain labeled neurons. These observations suggest that the McIntyre-B strain was transported preferentially in the retrograde direction by “first-order” neurons that innervate the cortical injection site.

The cortical injections of the McIntyre-B strain also resulted in labeled neurons at subcortical sites known to project to VLo and VPLo (for review, see refs. 8, 9, 12, and 13). For example, densely labeled neurons were present within specific portions of the thalamic reticular nucleus (Fig. 1A), the globus pallidus (Figs. 1B and 2 Upper), and the contralateral deep cerebellar nuclei (Fig. 1C and D). The labeled neurons within the globus pallidus were confined almost exclusively to mid-rostrorocaudal levels of the internal segment of this nucleus. Within the internal segment, labeled neurons formed two distinct clusters (Fig. 2 Upper), one ventrally in the outer portion of the internal segment and the other ventrally in its inner portion. At the survival time employed, the ratio of labeled neurons in the outer portion to those in the inner portion was 4:1. The labeled neurons within the deep cerebellar nuclei were confined to caudal portions of the anterior interpositus nucleus and to dorsal portions of mid-rostrorocaudal levels of the dentate nucleus. In prior studies, the same region of dentate contained labeled neurons after transneuronal transport of wheat germ agglutinin-horseradish peroxidase conjugate from the arm area of the primary motor cortex (8, 19). Furthermore, the locations of labeled neurons in the deep cerebellar nuclei and in the internal segment of the globus pallidus correspond to the regions of these nuclei where electrophysiological studies have found neuron activity related to arm movements (e.g., refs. 20–24). Thus, the subcortical distribution of labeled neurons is consistent with retrograde transneuronal transport of the McIntyre-B strain from the arm area of the primary motor cortex through pallidothalamocortical and cerebellothalamocortical circuits to “second-order” neurons in arm areas of the internal segment of the globus pallidus and the deep cerebellar nuclei (Fig. 3 Left).

A strikingly different pattern of transport was observed with HSV-1(H129). Cortical injections of this virus strain resulted in densely labeled neurons at all the cortical, subcortical, and spinal cord regions known to receive input from the primary motor cortex (for review, see ref. 15). For example, large numbers of labeled neurons were found within the putamen (Fig. 2 Lower) and the pontine nuclei (Fig. 4). Furthermore, these labeled neurons were confined to those parts of the putamen and pontine nuclei that are known to receive input from the arm area of the primary motor cortex (25–29). These observations suggest that the H129 strain was transported in the anterograde direction by first-order neurons in the primary motor cortex and was then transported transneuronally to label second-order neurons that are the targets of motor cortex efferents.

Labeled neurons also were found at sites known to project to the primary motor cortex (e.g., ventrolateral thalamus, cortical areas in the frontal and parietal lobes) (Fig. 4D). However, most sites that innervate the primary motor cortex also receive projections from it. Therefore, it is unclear whether these neurons were labeled by retrograde or anterograde transport of HSV-1(H129).

Perhaps of greater importance, the cortical injections of the H129 strain also resulted in labeled neurons at subcortical sites known to receive input from the putamen and pontine nuclei (1, 3, 4, 30–32). For example, densely labeled neurons were present within specific regions of the globus pallidus (Fig. 2 Lower) and the contralateral cerebellar cortex (Fig. 4 B and C). The labeled neurons in the globus pallidus were confined largely to ventral regions of the caudal third of the external segment of this nucleus (Fig. 2 Lower). The ratio of labeled neurons in the external segment to those in the internal segment was 10:1. The small number of neurons that were labeled in the internal segment were located largely within ventral regions of its outer portion (i.e., the same part of the outer portion that contained labeled neurons after cortical injections of the McIntyre-B strain). The location of labeled neurons in the external segment corresponds to the region of this segment where prior electrophysiological studies have found neuron activity related to arm movements (20–24). Thus, the distribution of labeled neurons in the basal ganglia is consistent with anterograde transneuronal trans-

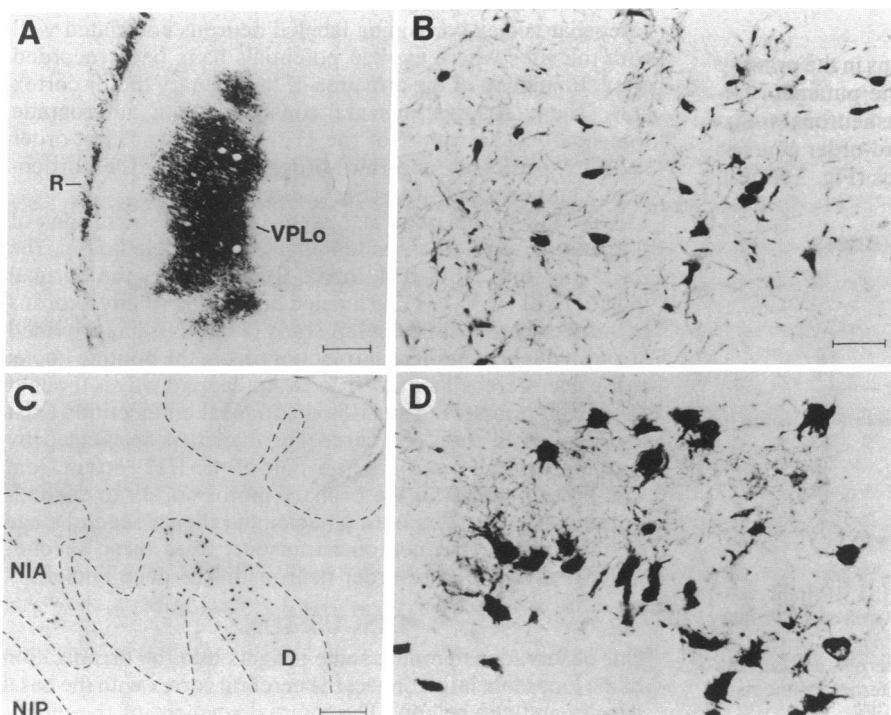

FIG. 1. Neurons labeled by transport of HSV-1(McIntyre-B) from the primary motor cortex. (A) Labeled neurons in the ventrolateral thalamus (VPLo) and in the reticular nucleus (R). (Bar = 1 mm.) (B) Labeled neurons in the internal segment of the globus pallidus. (Bar = 100 μ m.) (C) Labeled neurons in the deep cerebellar nuclei. Dashed lines outline the dentate (D), anterior interpositus (NIA) and posterior interpositus (NIP) nuclei (lower left) and a portion of cerebellar cortex (upper right). No labeled neurons were found in the NIP. (Bar = 500 μ m.) (D) Labeled neurons in the dentate nucleus. Note the differences in cell size and dendritic branching between cerebellar and pallidal neurons. (Scale is in B.)

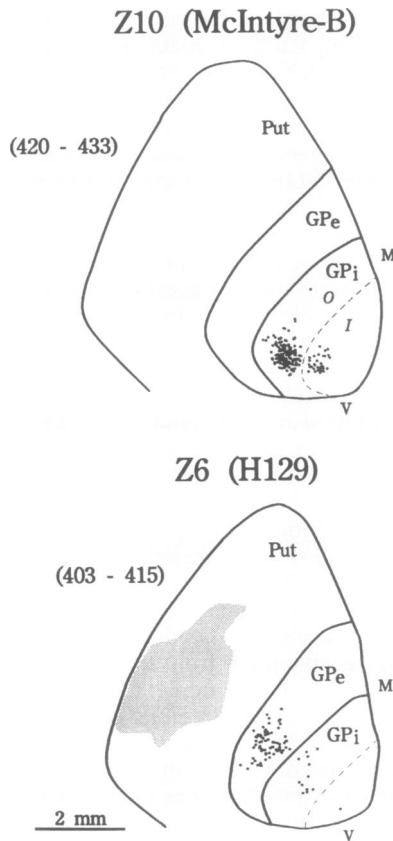

FIG. 2. Distribution of labeled neurons in the putamen and globus pallidus after injections of HSV-1 into the arm area of the primary motor cortex. (Upper) HSV-1(McIntyre-B), animal Z10. (Lower) HSV-1(H129), animal Z6. Shown are outlines of cross sections through the putamen (PUT) and globus pallidus external (GPe) and internal (GPi) segments. A dashed line indicates the border between the outer (O) and inner (I) portions of GPi. Six sections, 100–150 μ m apart, were overlapped to produce each diagram. Numbers in parentheses next to each outline represent the range of the sections. Small dots indicate the location of labeled neurons in GPe and GPi. Shading indicates the location of large numbers of labeled neurons in PUT. M, medial; V, ventral.

port of the H129 strain from first-order neurons in the primary motor cortex to second-order neurons in the putamen, followed by a second stage of anterograde transneuronal transport from these second-order neurons to third-order neurons in the external segment of the globus pallidus (Fig. 3 Right).

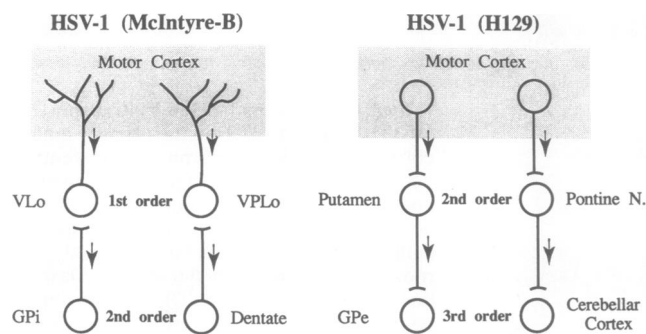

FIG. 3. Patterns of transport observed with HSV-1(McIntyre-B) or HSV-1(H129). Virus was injected into the arm area of the primary motor cortex. Arrows indicate the direction of virus transport. (Left) Retrograde transneuronal transport. (Right) Anterograde transneuronal transport. GPI and GPe, internal and external segments of globus pallidus; N., nuclei. See the text for details.

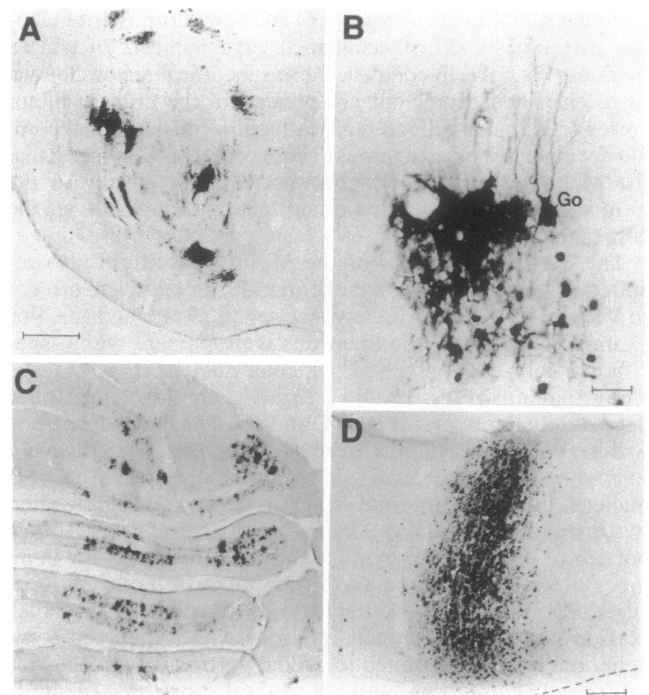

FIG. 4. Neurons labeled by transport of HSV-1(H129) from the primary motor cortex. (A) Labeled neurons in the pontine nuclei. (Bar = 1 mm.) (B) A patch of labeled granule cells and a Golgi cell (Go) in cerebellar cortex. (Bar = 30 μ m.) (C) Multiple patches of labeled neurons in the granular layer of cerebellar cortex. (Scale is in A.) (D) A "column" of labeled neurons in cerebral cortex buried within the dorsal bank of the cingulate sulcus. The dashed line indicates the border between white and gray matter. (Bar = 300 μ m.)

In the cerebellum, multiple patches of labeled neurons were found contralaterally in vermal, paravermal, and lateral portions of the anterior and posterior lobes of cerebellar cortex (Fig. 4C). The patches of labeled neurons were located in the granular cell layer, where two types of cerebellar neurons, granule and Golgi cells, were labeled (Fig. 4B). Both cell types are known to be contacted by the (mossy fiber) afferents from the pontine nuclei (1, 2, 30, 31). The regions of cerebellar cortex containing labeled neurons correlated well with the sites where evoked potentials have been recorded after stimulation of the arm area of the primary motor cortex (33). These observations are consistent with anterograde transneuronal transport of the H129 strain from first-order neurons to second- and third-order neurons in the cortico-pontocerebellar pathway (Fig. 3 Right).

Some labeled neurons also were found in the portions of the dentate and interpositus that were labeled after the injections with HSV-1(McIntyre-B). However, the cortical injections of HSV-1(H129) labeled only half as many neurons in the deep cerebellar nuclei. A study (34) in cats has provided strong evidence for direct projections from the pontine nuclei to the deep cerebellar nuclei, and a similar pathway is thought to exist in primates. Thus, the anatomical connections exist for neurons in the deep cerebellar nuclei to be labeled by anterograde transneuronal transport of the H129 strain from first-order neurons in the primary motor cortex to second-order neurons in the pontine nuclei and then a second stage of anterograde transneuronal transport from these second-order neurons to third-order neurons in the deep nuclei.

DISCUSSION

Our observations provide some insights into the organization of the loops that interconnect the cerebral cortex with the basal ganglia and cerebellum. The internal segment of the globus

pallidus and the deep cerebellar nuclei are the major sources of efferent signals from the basal ganglia and cerebellum. Retrograde transneuronal transport of the McIntyre-B strain from the arm area of the primary motor cortex labeled neurons in the internal segment of the globus pallidus and in two deep cerebellar nuclei, dentate and interpositus. This result supports suggestions that the arm area of the primary motor cortex is a target of outputs from both the basal ganglia and cerebellum (9, 35). Another interesting finding of the present study is that the majority of the pallidal neurons labeled after anterograde transneuronal transport of the H129 strain from the arm area of the primary motor cortex were located in the external segment of the globus pallidus. There is evidence from other studies that separate populations of putamen neurons project to the external and internal segments of the globus pallidus (36). Thus, one interpretation of our result is that the primary motor cortex terminates primarily on those putamen neurons which innervate the external segment. One wonders whether efferents from other cortical areas might more directly influence pallidal output by terminating on putamen neurons that innervate the internal segment. Our results suggest that transneuronal transport of different strains of HSV-1 can be used to generate and test hypotheses about information flow in basal ganglia and cerebellar circuitry. Indeed, virus transport may prove to be an important tool for exploring the complex systems of interconnections that characterize the central nervous system of primates.

Our findings may have some important clinical relevance. HSV-1 is the cause of cold sores. Approximately 90% of the adult population has antibody to this virus. Yet, in some individuals, HSV-1 invades the brain or retina to produce life-threatening encephalitis or sight-threatening acute retinal necrosis (37, 38). Why some strains of HSV-1 succeed and others fail to invade neural tissues and produce clinical disease has remained an enigma. Previous work in mice has shown that individual strains of HSV-1 differ dramatically with respect to pathogenicity and exhibit distinct patterns of neurovirulence and retinotransmission (5, 39, 40). The results of the present study in primates suggest that strain-dependent differences in the direction and extent of transneuronal transport may represent important factors that contribute to the ability of a particular HSV-1 strain to produce neurological disease.

The two strains of HSV-1 used in our study are known to differ with respect to their pattern of polypeptide synthesis (41) and the location of restriction endonuclease cleavage sites within the virus genome (42). Thompson and coworkers (43–46) explored the genetic basis for the neurovirulence of HSV-1 but did not specifically examine patterns of axonal transport. Thus, the precise genetic bases for the differences in axonal transport we observed between the McIntyre-B and H129 strains remain to be fully elucidated. Similarly, the properties of neurons that enable different strains of HSV-1 to be transported transneurally in either the retrograde or the anterograde direction are unknown. Nevertheless, our findings suggest that differences among HSV-1 strains might be exploited experimentally to probe the underlying mechanisms of transneuronal transport and to examine the contribution of these mechanisms to clinical disease.

We thank Dr. D. I. Bernstein of the Gamble Institute of Medical Research (Cincinnati) for HSV-1(McIntyre-B), Ms. Sarah Fitzpatrick for histological assistance, and Ms. Renee Stewart for assistance with the preparation of HSV-1(H129). This work was supported by grants from the Veterans Affairs Medical Research Service (P.L.S.), the National Institutes of Health (RO1 NS24328 to P.L.S.; PO1 NS25569 to R.D.D.), and the Joe and Emily Lowe Foundation, Palm Beach, FL (R.D.D.).

1. Allen, G. I. & Tsukahara, N. (1974) *Physiol. Rev.* **54**, 957–1006.
2. Brooks, V. B. & Thach, W. T. (1981) in *Handbook of Physiology. Section I: The Nervous System. Vol. II: Motor Control*, ed. Brooks, V. B. (Am. Physiol. Soc., Bethesda, MD), pp. 877–946.
3. DeLong, M. R. & Georgopoulos, A. P. (1981) in *Handbook of Physiology. Section I: The Nervous System. Vol. II: Motor Control*, ed. Brooks, V. B. (Am. Physiol. Soc., Bethesda, MD), pp. 1017–1061.
4. Alexander, G. E., DeLong, M. R. & Strick, P. L. (1986) *Annu. Rev. Neurosci.* **9**, 357–381.
5. Dix, R. D., McKendall, R. R. & Baringer, J. R. (1983) *Infect. Immun.* **40**, 103–112.
6. McLean, J. H., Shipley, M. T. & Bernstein, D. I. (1989) *Brain Res. Bull.* **22**, 867–881.
7. Asanuma, H. & Rosen, I. (1972) *Exp. Brain Res.* **14**, 243–256.
8. Orioli, P. J. & Strick, P. L. (1989) *J. Comp. Neurol.* **288**, 612–626.
9. Holsapple, J. W., Preston, J. B. & Strick, P. L. (1991) *J. Neurosci.*, in press.
10. Ugolini, G., Kuypers, H. G. J. M. & Simmons, A. (1987) *Brain Res.* **422**, 242–256.
11. Ugolini, G., Kuypers, H. G. J. M. & Strick, P. L. (1989) *Science* **243**, 89–91.
12. Schell, G. R. & Strick, P. L. (1984) *J. Neurosci.* **4**, 539–560.
13. Jones, E. G. (1985) *Thalamus* (Plenum, New York).
14. Wiesendanger, R. & Wiesendanger, M. (1985) *Exp. Brain Res.* **59**, 91–104.
15. Leichnetz, G. R. (1986) *J. Comp. Neurol.* **254**, 460–492.
16. Ghosh, S., Brinkman, C. & Porter, R. (1987) *J. Comp. Neurol.* **259**, 424–444.
17. Matelli, M., Luppino, G., Fogassi, L. & Rizzolatti, G. (1989) *J. Comp. Neurol.* **280**, 468–488.
18. Darian-Smith, C., Darian-Smith, I. & Cheema, S. S. (1990) *J. Comp. Neurol.* **299**, 17–46.
19. Wiesendanger, R. & Wiesendanger, M. (1985) *Exp. Brain Res.* **59**, 105–117.
20. DeLong, M. R., Crutcher, M. D. & Georgopoulos, A. P. (1985) *J. Neurophysiol.* **53**, 530–543.
21. Anderson, M. E. & Horak, F. B. (1985) *J. Neurophysiol.* **54**, 433–448.
22. Thach, W. T., Perry, J. G. & Schieber, M. H. (1982) *Exp. Brain Res. Suppl.* **6**, 440–454.
23. Hamada, I., DeLong, M. R. & Mano, N. (1990) *J. Neurophysiol.* **64**, 1892–1906.
24. Mink, J. W. & Thach, W. T. (1991) *J. Neurophysiol.* **65**, 273–300.
25. Kunzle, H. (1975) *Brain Res.* **88**, 195–209.
26. Jones, E. G., Coulter, J. D., Burton, H. & Porter, R. (1977) *J. Comp. Neurol.* **173**, 53–80.
27. Brodal, P. (1978) *Brain* **101**, 251–283.
28. Wiesendanger, R., Wiesendanger, M. & Ruegg, D. G. (1979) *Neuroscience* **4**, 747–765.
29. Liles, S. L. & Updyke, B. (1985) *Brain Res.* **339**, 245–255.
30. Bloedel, J. R. & Courville, J. (1981) in *Handbook of Physiology. Section I: The Nervous System. Vol. II: Motor Control*, ed. Brooks, V. B. (Am. Physiol. Soc., Bethesda, MD), pp. 735–829.
31. Ito, M. (1984) *The Cerebellum and Neural Control* (Raven, New York).
32. Hedreen, J. C. & DeLong, M. R. (1991) *J. Comp. Neurol.* **304**, 569–595.
33. Sasaki, K., Oka, H., Kawaguchi, S., Jinnai, K. & Yasuda, T. (1977) *Exp. Brain Res.* **29**, 419–428.
34. Shinoda, Y., Sugiuchi, Y. & Futami, T. (1987) *Exp. Brain Res.* **67**, 299–315.
35. Nambu, A., Yoshida, S. & Jinnai, K. (1988) *Exp. Brain Res.* **71**, 658–662.
36. Parent, A., Smith, Y., Filion, M. & Dumas, J. (1989) *Neurosci. Lett.* **96**, 140–144.
37. Johnson, R. T. (1982) *Viral Infections of the Nervous System* (Raven, New York).
38. Lewis, M. L., Culbertson, W. W., Post, J. D., Miller, D., Kokame, G. T. & Dix, R. D. (1989) *Ophthalmology* **96**, 875–878.
39. Richards, J. T., Kern, E. R., Overall, J. C., Jr., & Glasgow, L. A. (1981) *J. Infect. Dis.* **144**, 464–471.
40. Dix, R. D., Hamasaki, D. I., Hurst, L., Stewart, R. V., Culbertson, W. W. & Lewis, M. L. (1990) *Invest. Ophthalmol. Visual Sci. Suppl.* **31**, 314.
41. Pereira, L., Cassai, E., Honess, R. W., Roizman, B., Terni, M. & Nahmias, A. (1976) *Infect. Immun.* **13**, 211–220.
42. Buchman, T. G., Simpson, T., Nosal, C. & Roizman, B. (1980) *Ann. N.Y. Acad. Sci.* **354**, 279–290.
43. Thompson, R. L. & Stevens, J. G. (1983) *Virology* **131**, 171–179.
44. Thompson, R. L., Wagner, E. K. & Stevens, J. G. (1983) *Virology* **131**, 180–192.
45. Thompson, R. L., Devi-Rao, G. V., Stevens, J. G. & Wagner, E. K. (1985) *J. Virol.* **55**, 504–508.
46. Thompson, R. L., Cook, M. L., Devi-Rao, G. B., Wagner, E. K. & Stevens, J. G. (1986) *J. Virol.* **58**, 203–211.