

Stable DNA heteroduplex formation catalyzed by the *Escherichia coli* RecA protein in the absence of ATP hydrolysis

(genetic recombination/DNA strand exchange/homologous DNA pairing/three-stranded DNA intermediate)

JOSEPH P. MENETSKI*[†], DAVID G. BEAR[‡], AND STEPHEN C. KOWALCZYKOWSKI*[§]

*Department of Molecular Biology, Northwestern University Medical School, Chicago, IL 60611; and [‡]Department of Cell Biology, University of New Mexico School of Medicine, Albuquerque, NM 87131

Communicated by Laszlo Lorand, September 18, 1989 (received for review May 24, 1989)

ABSTRACT A question remaining to be answered about RecA protein function concerns the role of ATP hydrolysis during the DNA-strand-exchange reaction. In this paper we describe the formation of joint molecules in the absence of ATP hydrolysis, using adenosine 5'-[γ -thio]triphosphate (ATP[γ S]) as nucleotide cofactor. Upon the addition of double-stranded DNA, the ATP[γ S]-RecA protein-single-stranded DNA pre-synaptic complexes can form homologously paired molecules that are stable after deproteinization. Formation of these joint molecules requires both homology and a free homologous end, suggesting that they are plectonemic in nature. This reaction is very sensitive to magnesium ion concentration, with a maximum rate and extent observed at 4–5 mM magnesium acetate. Under these conditions, the average length of heteroduplex DNA within the joint molecules is 2.4–3.4 kilobase pairs. Thus, RecA protein can form extensive regions of heteroduplex DNA in the presence of ATP[γ S], suggesting that homologous pairing and the exchange of the DNA molecules can occur without ATP hydrolysis. A model for the RecA protein-catalyzed DNA-strand-exchange reaction that incorporates these results and its relevance to the mechanisms of eukaryotic recombinases are presented.

The RecA protein-catalyzed DNA-strand-exchange reaction has been divided into at least three distinct phases (1, 2). In the first phase of this reaction, RecA protein binds to single-stranded DNA (ssDNA) in the presence of ATP (pre-synapsis). During the second phase, synapsis, the ssDNA and double-stranded DNA (dsDNA) are brought together by RecA protein. Homologous pairing of the two DNA molecules and joint molecule formation occur within the synaptic complex. The initial heteroduplex joint is extended throughout the DNA molecule in the final phase of the DNA-strand-exchange reaction, termed branch migration. Early experiments suggested that RecA protein must bind and hydrolyze ATP to ADP and inorganic phosphate to form stable heteroduplex DNA (3, 4); however, the mechanistic requirement for ATP hydrolysis is unknown.

Experiments using the nonhydrolyzable ATP analogue, adenosine 5'-[γ -thio]triphosphate (ATP[γ S]), were performed to examine the need for ATP hydrolysis during the DNA-strand-exchange reaction. It was shown that the first two phases of this reaction can occur using this ATP analogue (4, 5). However, the joint molecules formed in the presence of ATP[γ S] were reported to require bound RecA protein for stability [i.e., they were paranemic in nature (4)]. Since plectonemic, as well as paranemic, joint molecules can be formed in the presence of ATP, it was suggested that conversion of paranemic to plectonemic joint molecules requires ATP hydrolysis (4). In related studies, addition of ATP[γ S] to an ongoing DNA-strand-exchange reaction was shown to

immediately stop formation of heteroduplex DNA (3). The data were interpreted to suggest that ATP hydrolysis was also required for the formation of extensive regions of heteroduplex DNA (after joint molecules are formed). Thus, homologous pairing and the formation of protein-stabilized paranemic joint molecules are thought to occur in the absence of ATP hydrolysis, whereas the formation of plectonemic joint molecules and extensive regions of heteroduplex DNA requires hydrolysis of ATP.

We now report the catalysis of DNA strand exchange in the presence of ATP[γ S]. Our data demonstrate that the joint molecules formed in the presence of ATP[γ S] are stable in the absence of RecA protein and are, therefore, plectonemic in nature. The average length of heteroduplex DNA in these joint molecules can be as much as 3.4 kilobase pairs (kb) with no detectable hydrolysis of ATP[γ S]. The relevance of these results to the role of ATP hydrolysis in the mechanism of the DNA strand exchange catalyzed by the *Escherichia coli* RecA protein and by other recombinases is discussed.

MATERIALS AND METHODS

Reagents. All chemicals used were reagent grade and solutions were made in glass-distilled H₂O. ATP and ATP[γ S] were purchased from Boehringer Mannheim; both were dissolved as concentrated stock solutions at pH 7.5. The concentrations of ATP and ATP[γ S] were determined spectrophotometrically using an extinction coefficient of $1.54 \times 10^4 \text{ cm}^{-1}\text{M}^{-1}$ at 260 nm.

RecA protein was purified from *E. coli* strain JC12772 (6) using a preparative protocol (S.C.K., unpublished protocol) based on spermidine acetate precipitation (7). Protein concentration was determined using an extinction coefficient of $2.7 \times 10^4 \text{ cm}^{-1}\text{M}^{-1}$ at 280 nm. Single-stranded DNA binding (SSB) protein was purified from strain RLM727 using a preparative protocol provided by Roger McMacken (The Johns Hopkins University). The concentration of SSB protein was determined using an extinction coefficient of $3 \times 10^4 \text{ cm}^{-1}\text{M}^{-1}$ at 280 nm. S1 nuclease was purchased from Pharmacia.

Phage M13 ssDNA and replicative form dsDNA were isolated as described (8). The replicative form was linearized using *EcoRI* restriction endonuclease. The concentration of M13 ssDNA and dsDNA was determined using extinction coefficients of 8784 and $6500 \text{ cm}^{-1}\text{M}^{-1}$ at 260 nm, respectively.

Nucleotide Hydrolysis. ATP[γ S] hydrolysis was determined using the method of Lanzetta *et al.* (9). Hydrolysis of ATP[γ S] was examined in a solution containing 1 mM ATP[γ S], 6 μM RecA protein, and 10 μM M13 ssDNA by using

standard DNA-strand-exchange buffer for as long as 8 hr. The background rate of ATP[γ S] hydrolysis under these conditions, in the absence of RecA protein, is 32 ± 1.9 nM ATP[γ S] per min (data not shown). No hydrolysis above background was observed in the presence of RecA protein, in either the absence or presence of ssDNA. Thus, the rate of ATP[γ S] hydrolysis by RecA protein must be less than 1.9 nM/min (or $k_{cat} < 0.3$ nM per min per μ M RecA protein). This value is in good agreement with that determined previously [0.7 nM per min per μ M RecA protein (10)].

DNA-Strand-Exchange Assay. The DNA-strand-exchange reaction was carried out in a solution of 6 μ M RecA protein, 0.9 μ M SSB protein, 10 μ M M13 ssDNA, 10 μ M M13 dsDNA, and 1 mM ATP[γ S] in standard reaction buffer (25 mM Tris acetate, pH 7.5/4 mM magnesium acetate/1 mM dithiothreitol), unless stated otherwise. The procedure used to form active presynaptic complexes in the presence of ATP[γ S] is essentially the same as described (5). The M13 ssDNA was preincubated with SSB protein for 10 min; RecA protein and ATP[γ S] were then added and the mixture was incubated for another 10 min. Finally, the reaction was initiated by the addition of M13 dsDNA. DNA samples were removed at various times, and the reaction was stopped with 1% SDS/50 mM EDTA at 37°C for 10 min to ensure deproteinization (4).

The agarose gel assay for measuring DNA-strand-exchange activity was conducted essentially as described (3). However, DNA samples were subjected to electrophoresis in the absence of ethidium bromide for 7 hr at 0.88 V/cm on 0.8% agarose gels in TAE (40 mM Tris acetate, pH 8.0/2 mM EDTA). These gels were later stained with ethidium bromide (1 μ g/ml) to visualize the DNA bands. Intermediate formation was quantified by scanning a photographic negative with a Zeineh soft laser scanning densitometer.

S1 Nuclease Assay. DNA heteroduplex formation was determined by S1 nuclease assay as described (3) with the following changes. Reactions were conducted exactly as described for the DNA-strand-exchange reaction, except that tritiated M13 dsDNA was used. Part of a single-reaction time-point sample was subjected to electrophoresis and a second portion was subjected to S1 nuclease digestion. Samples were incubated at 37°C with 1% SDS for 10 min prior to the addition of S1 nuclease to disrupt ATP[γ S]-RecA protein-DNA complexes (4). After S1 nuclease treatment, 10% (wt/vol) trichloroacetic acid was added and acid-insoluble labeled DNA was pelleted by centrifugation in an Eppendorf centrifuge for 10 min. The total radioactivity (cpm₁₀₀) in the supernatant was determined as total cpm of an untreated sample before centrifugation. Background radioactivity (cpm₀) was determined as total cpm of an untreated sample after centrifugation. The fraction of nuclease-sensitive DNA was calculated as [(cpm_{supernatant} - cpm₀)/(cpm₁₀₀ - cpm₀)]. Since complete heteroduplex DNA formation would render only 50% of the DNA sensitive to nuclease treatment, the percent DNA heteroduplex was determined as the fraction of nuclease-sensitive DNA \times 200.

Electron Microscopy. The DNA-strand-exchange reaction was carried out as described above. After agarose gel electrophoresis, the bands corresponding to the various intermediate species were excised and electroeluted from the gel. Subsequent gel electrophoresis of the eluted DNA bands verified that their mobility was unaltered by this procedure.

All samples were applied to the grid without prior fixation. A 5- μ l drop of sample in 10 mM Tris-HCl, pH 7.5/1 mM EDTA was applied to the film side of a freshly glow-discharged 400-mesh grid containing an 8-nm carbon film. The sample was allowed to adsorb for 5 min at ambient temperature. The grid was then placed in a spermidine solution and processed as described (11). The grids were rotary shadowed with tungsten in an Edwards 306A vacuum coater and imaged at 50 kV in a Hitachi H600-3 transmission

electron microscope. The size of the DNA heteroduplex joint was estimated by measuring the length of the looped dsDNA that terminates in a condensed ssDNA region and by relating it to the size of full-length M13 dsDNA; only intermediates 1 and 2 were analyzed due to the difficulty in unambiguously estimating the lengths of the heteroduplex DNA joints for intermediates 3 and 4.

RESULTS

DNA-Strand-Exchange Intermediates Are Formed in the Absence of ATP Hydrolysis. After addition of linear M13 dsDNA, stable joint molecules that did not require RecA protein for stability were observed using the modified agarose gel assay (Fig. 1). Within 10 min, approximately 80% of the input M13 dsDNA was incorporated into DNA species that comigrated with intermediates formed in the ATP-dependent reaction[†]; there was no consistent detectable formation of the final reaction product, gapped dsDNA. In the absence of SSB

[†]For simplicity, all of the intermediate species (Fig. 1 *Inset*) have been added together and are reported as total intermediate formed.

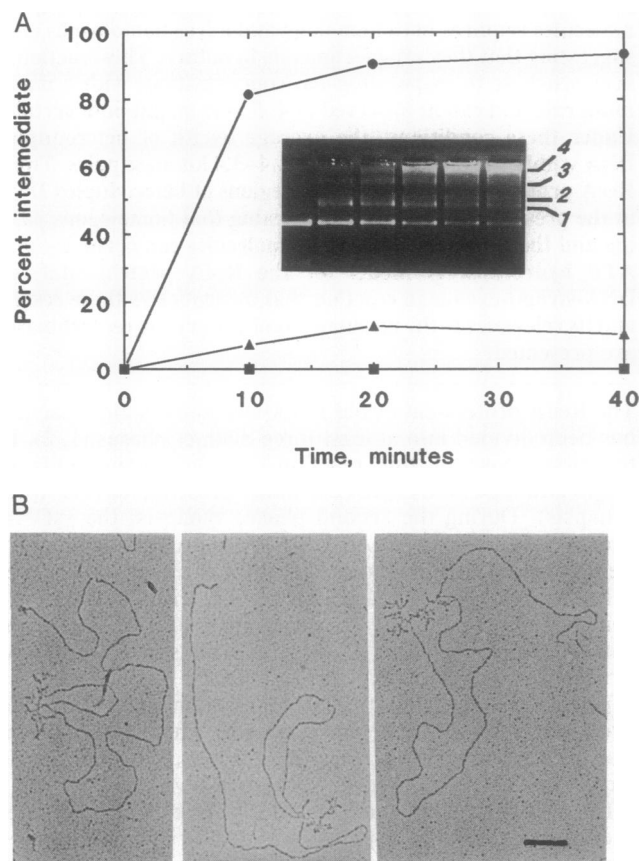

FIG. 1. Formation of DNA-strand-exchange intermediates in the presence of ATP[γ S]. (A) Time course of DNA-strand-exchange intermediate formation reported as the sum of all the intermediate DNA species observed. Reaction mixtures contained linear M13 dsDNA and circular M13 ssDNA (\bullet); supercoiled M13 dsDNA and circular M13 ssDNA (\blacktriangle); linear pBR322 and circular M13 ssDNA (\blacksquare). (*Inset*) Agarose gel containing reaction products formed between linear M13 dsDNA and circular M13 ssDNA. The lanes (left to right) contain 0-, 2.5-, 5-, 10-, 20-, and 40-min reaction time points. Bands 1-4 are explained in the text. (B) Electron micrographs of intermediates 1 and 2. The linear dsDNA is easily discernible whereas the ssDNA is condensed; heteroduplex DNA is visible as a loop of dsDNA that is terminated by a condensed region of ssDNA. Shown are representative joint molecules containing (from left to right) 1.3, 3.5, and 5.1 kb of heteroduplex DNA. (Bar = 1000 Å.)

protein, the yield of intermediates was 5–10% of that obtained in the presence of SSB protein. The structure of the joint molecules was established by electron microscopy. The intermediates labeled 1 and 2 are joint molecules consisting of one linear dsDNA molecule and one ssDNA molecule (Fig. 1B), intermediate 3 consists of from two to four dsDNA molecules and at least one ssDNA molecule (data not shown), and intermediate 4 is a highly entwined structure consisting of an indeterminate number of DNA molecules (data not shown).

Very little intermediate was formed when supercoiled M13 dsDNA was used as the dsDNA substrate (Fig. 1A). Supercoiled M13 dsDNA could form only paranemic joint molecules with circular M13 ssDNA, suggesting that the DNA species formed with linear M13 dsDNA were plectonemic in nature. (The small amount of joint molecules formed with supercoiled dsDNA was probably due to a trace of nicked dsDNA in the DNA preparation.) No intermediate species were observed when heterologous linear pBR322 dsDNA was used as a substrate, showing that formation of intermediates required DNA sequence homology.

Effect of RecA Protein Concentration on ATP[γ S]-Dependent Joint Molecule Formation. The rate of joint molecule formation, in the presence of ATP[γ S], was determined as a function of RecA protein concentration (Fig. 2). Both the observed rate and extent of the ATP[γ S]-dependent reaction increased with increasing RecA protein concentration to approximately 4 μ M. This increase was not linear at low protein concentrations and appeared to be slightly sigmoidal. Saturation at 4 μ M RecA protein yielded an apparent stoichiometry of 2.5 ± 0.5 nucleotides of ssDNA per RecA protein monomer. This stoichiometry is similar to the value observed for the ATP-dependent reaction [2–4 nucleotides of ssDNA per RecA protein monomer (12)], showing that the amount of RecA protein required for either reaction is similar.

Formation of DNA-Strand-Exchange Intermediates in the Presence of ATP[γ S] Is Very Sensitive to Magnesium Ion Concentration. Honigberg *et al.* (5) showed that the formation of paranemic joint molecules occurs at a lower magnesium ion concentration (4 mM) than required for branch migration (10 mM). Thus, we were interested in the effect of magnesium ion concentration on the formation of plectonemic joint molecules in the presence of ATP[γ S]. As shown in Fig. 3, the rate of joint molecule formation was very sensitive to magnesium concentration and exhibited a maximum between 4 and 5 mM magnesium acetate. The maximum percent of intermediate species formed under these conditions followed the same trend (Fig. 3).

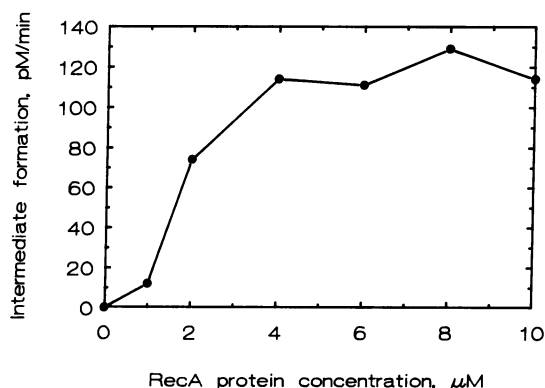

FIG. 2. Effect of RecA protein concentration on the formation of intermediates in the presence of ATP[γ S]. The relative error for each point is approximately 20%.

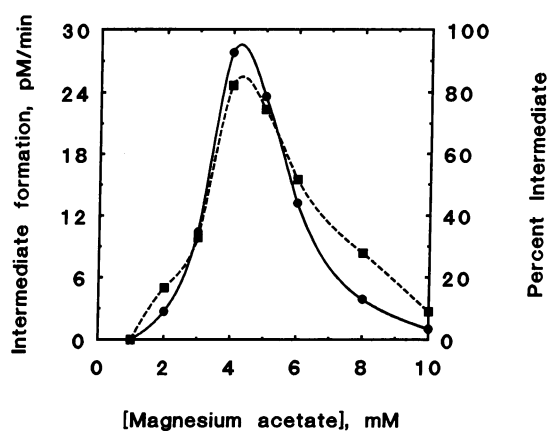

FIG. 3. Effect of magnesium acetate concentration on the formation of DNA-strand-exchange intermediates in the presence of ATP[γ S]. The magnesium acetate concentration in the DNA-strand-exchange reaction is indicated. Results are shown for the rate of intermediate formation (●) and the maximum extent of intermediate formation (■).

Extensive Heteroduplex DNA Can Be Formed in the Absence of ATP Hydrolysis. The average length of the heteroduplex DNA joint can be determined by comparing the results from the gel assay with those from an assay that determines the total percent of heteroduplex DNA formed (i.e., the S1 nuclease assay). Fig. 4 shows that the increase in amount of intermediates formed (gel assay) was paralleled by an increase in the total percent of DNA heteroduplex formed (S1 nuclease assay). Comparison of these data gave an average length for the DNA heteroduplex region of 2.4–3.4 kb per dsDNA molecule. The results also demonstrate that within 2.5 min the average length of a plectonemic joint molecule was at least 2400 base pairs. Interestingly, the length of the heteroduplex region increased from 2.4 kb to 3.4 kb over a 20-min period (Fig. 4). This observation suggests that the size of the nascent plectonemic joint molecule can grow an additional 1 kb in the absence of detectable ATP[γ S] hydrolysis.

The average size of the DNA heteroduplex region was also derived from the structures seen in the electron micrographs (Fig. 1B). The size of the DNA heteroduplex joint in intermediates 1 and 2 (formed after 10 min of reaction) ranged from 0.3 to 5.1 kb, with the mean size being 2.3 kb. This is

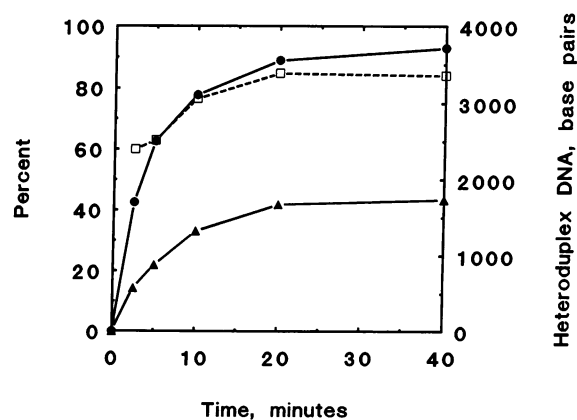

FIG. 4. Average length of heteroduplex DNA formed in the ATP[γ S]-dependent reaction. The DNA-strand-exchange reaction and S1 nuclease assay were conducted by using 20 μ M M13 dsDNA. The percent intermediate as determined by the agarose gel assay (●), percent heteroduplex as determined by the S1 nuclease assay (▲), and the average length of heteroduplex DNA (■) determined from the above two assays are shown.

in good agreement with the S1 nuclease data that show an average length of 3.0 kb.

Under the experimental conditions used for DNA strand exchange, ATP[γ S] hydrolysis was not observed. The maximum rate of ATP[γ S] hydrolysis by RecA protein under these conditions was 1.9 nM ATP[γ S] per min. The rate of heteroduplex DNA formation determined from the data in Fig. 4 was 0.58 μ M base pairs per min. Comparing this approximate rate of heteroduplex DNA formation with the maximum rate of ATP[γ S] hydrolysis gave a maximum of 0.003 ATP[γ S] molecules hydrolyzed per base pair formed. Thus these results show that extensive regions of heteroduplex DNA can be formed in the absence of significant ATP hydrolysis.

DISCUSSION

We examined the ability of RecA protein to promote DNA strand exchange in the presence of ATP[γ S]. Under optimal conditions, presynaptic complexes formed in the presence of ATP[γ S] can form joint molecules efficiently. Joint molecule formation requires homology and a free end, suggesting that these intermediates are plectonemic in nature. The formation of joint molecules in the presence of ATP[γ S] is very sensitive to magnesium ion concentration and shows a maximum rate and extent at 4–5 mM magnesium acetate. The rate of joint molecule formation at 4 mM magnesium acetate, in the presence of ATP[γ S], is similar to the rate observed in the presence of ATP (at optimal conditions, 8–10 mM magnesium acetate). Surprisingly, the average length of heteroduplex DNA produced by RecA protein in the ATP[γ S]-dependent reaction is 2.4–3.4 kb. Formation of this heteroduplex DNA occurs in the absence of observable ATP[γ S] hydrolysis.

These results may appear to contradict previous studies that show that very little heteroduplex DNA is formed in the presence of ATP[γ S] (4, 12). However, the reactions were typically carried out in buffer containing 8–12 mM magnesium ion. This magnesium ion concentration greatly inhibits the ATP[γ S]-dependent formation of heteroduplex DNA (Fig. 3). Therefore, our results actually support those obtained in previous studies. The reason for this optimum in magnesium acetate concentration is unclear. Low magnesium ion concentrations are probably insufficient to stimulate the formation of an essential RecA protein-dependent structure (e.g., an active presynaptic filament); the requirement for at least 2–4 mM magnesium ion is also observed in the

ATP-dependent DNA-strand-exchange reaction (12, 13). The decrease in ATP[γ S]-dependent activity above 5 mM magnesium ion is not observed in the ATP-dependent reaction until the magnesium ion concentration exceeds 15 mM (12); the reason for this inhibition is also unknown but may be related to extensive aggregation of RecA protein resulting in nonproductive structures (7).

The formation of extensive heteroduplex DNA in the absence of ATP hydrolysis is important with regard to the kinetic mechanism of the RecA protein-catalyzed DNA-strand-exchange reaction. DNA strand exchange proceeds through, at least, three phases (1, 2), presynapsis, synapsis (conjunction and joint molecule formation), and branch migration. In the presence of ATP, joint molecules form rapidly (<5 min) and contain about 300–500 base pairs of heteroduplex DNA (3); extension of these joint molecules through branch migration then proceeds slowly and can take as long as 20 min. Here we show that RecA protein can form as much as 2.4 kb of heteroduplex DNA in less than 2.5 min in the absence of ATP hydrolysis (Fig. 4). Thus, either 2.4 kb of heteroduplex DNA can be formed during the synaptic phase of this reaction or branch migration to 2.4 kb can occur rapidly and in the absence of nucleotide hydrolysis.

An important conclusion is that the pathway for RecA protein-catalyzed DNA heteroduplex formation can proceed by a mechanism that does not require ATP hydrolysis as an obligatory step [e.g., the rotation model proposed (14)]. The mechanism by which we envision DNA heteroduplex formation occurring in the presence of ATP[γ S] is depicted in Fig. 5. In Fig. 5 *Left*, homologous pairing is shown to occur along the length of the two DNA molecules. This is consistent with electron microscopic studies that show the dsDNA molecule is completely taken up into the presynaptic filament before a displaced tail is observed (16, 17). Enzymatic studies also suggest that homologous pairing occurs over the entire length of DNA homology within 2–5 min (18). In addition, our data demonstrate that within several minutes the ATP[γ S]-RecA protein-ssDNA filament is in homologous alignment with the dsDNA molecule over at least 2.4 kb. This suggests that homologous contacts are formed over large regions of the DNA molecule within several minutes and that the formation of these contacts does not require ATP hydrolysis (only ATP binding).

The formation of this paired complex results in an intermediate complex containing RecA protein and three strands of DNA that are homologously aligned (Fig. 5 *A* and *B*). The

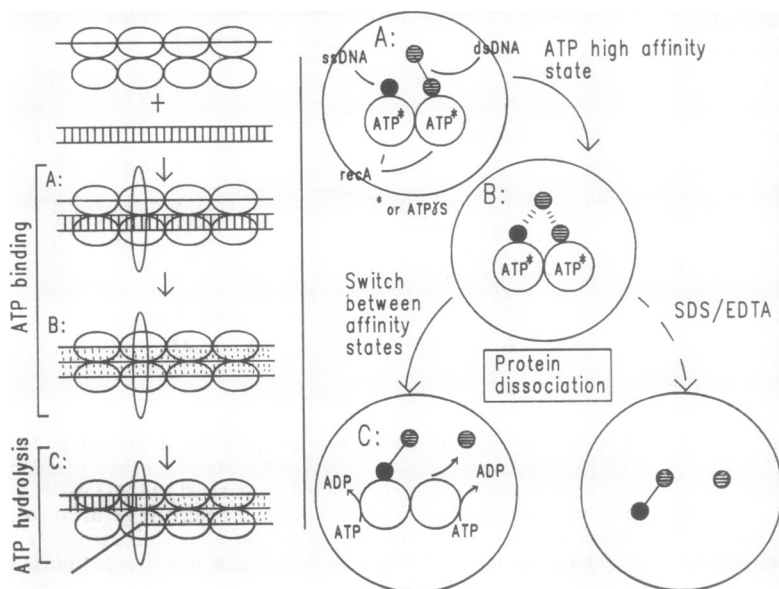

FIG. 5. Molecular model for the role of ATP hydrolysis during the DNA-strand-exchange assay. The presynaptic filament is formed in the presence of ATP (or ATP[γ S]). RecA protein bound to ssDNA is shown as a dimer based on evidence described elsewhere (ref. 15; S. D. Lauder and S.C.K., unpublished results). The cross-section of each intermediate step is shown on the right. (A) dsDNA is bound to the presynaptic filament. (B) Homologous contacts are formed in a triple-stranded intermediate. The formation of this intermediate does not require ATP hydrolysis and can be formed with ATP[γ S]. (C) Protein dissociation is accomplished by one of two mechanisms: normally, in the presence of ATP, the formation of the low-affinity ADP-RecA protein complex allows the orderly dissociation of RecA from the displaced homologous strand; in the presence of ATP[γ S], addition of deproteinizing agents removes the RecA protein and the complementary strand can anneal with either homologous strand.

DNA in this three-stranded intermediate must be poised for DNA strand exchange, and we envision this intermediate as a kinetic transition state. In this protein-DNA transition state complex, the conformation of the dsDNA is such that the complementary strand is no longer stably paired with its original homologous strand while the incoming ssDNA is positioned so as to base pair with its complement. In Fig. 5B, this intermediate transition state is depicted as symmetrical with regard to the three DNA strands, but any degree of asymmetry could be accommodated. Resolution of this structure requires only protein dissociation (Fig. 5C). This occurs either by deproteinization (i.e., SDS/EDTA treatment) when ATP[γ S] is present or by ATP hydrolysis when ATP is present. In either case, upon protein dissociation, the freed DNA can reassociate to form either heteroduplex DNA or parental DNA.

What then is the role of ATP hydrolysis during the ATP-dependent DNA-strand-exchange reaction? The answer may be simply to induce dissociation of the RecA protein-DNA complex through the conversion of ATP to ADP and to provide directionality by doing so. The product of ATP hydrolysis, ADP, decreases the affinity of RecA protein for DNA and increases the rate of transfer (i.e., dissociation) from one DNA molecule to another (19, 20). This suggests that production of an ADP-RecA protein complex allows the DNA to be released from the protein-DNA complex (Fig. 5). This dissociation event is likely to occur at the end of a cooperative cluster of bound RecA protein (19). It is reasonable to suggest that this dissociation from the end of a filament could provide the polarity observed in DNA-strand-exchange reaction. This proposal differs mechanistically from those proposed previously in which the polarity of the DNA-strand-exchange reaction derives from a polar association of RecA protein with DNA. These results may suggest that the essential role of ATP hydrolysis in postsynaptic steps is solely to generate the release factor, ADP.

ATP hydrolysis may also serve a function at the presynaptic step; it may permit RecA protein to cycle on and off the ssDNA molecule to produce a continuous presynaptic filament. The presynaptic filaments formed in the presence of ATP[γ S] appear to have kinks and acute bends as visualized by electron microscopy (5). It is likely that any flaw in the formation of the ATP[γ S]-dependent presynaptic complex will be maintained during the time course of the DNA-strand-exchange reaction, due to the stability of the ATP[γ S]-RecA protein-ssDNA complex (19). It is possible that these discontinuities in the presynaptic filament impede complete extension of heteroduplex DNA joints. In this regard, we feel that a function of SSB protein in the ATP[γ S]-dependent reaction is to permit formation of a contiguous RecA protein filament by limiting nucleation sites (5); in the absence of SSB protein, the binding of RecA protein-ATP[γ S] complex to ssDNA should be stochastic and necessarily discontinuous due to the essentially irreversible binding of this highly stable complex. In contrast, in the presence of ATP, hydrolysis of ATP allows RecA protein to dissociate from the ssDNA and to repair such imperfections by reassembly.

Finally, it is possible that the ATP[γ S]-dependent reaction occurs by a different mechanism and is not related to the ATP-dependent reaction. This possibility is unlikely because many of the characteristics of the ATP[γ S]-RecA protein complex are very similar (if not identical) to the ATP-RecA protein complex: (i) from electron microscopy, the structure of the ATP[γ S]-RecA protein-ssDNA complex is morphologically very similar to the ATP-RecA protein-ssDNA complex (21); (ii) the high-affinity ssDNA binding state of RecA protein possesses similar properties in the presence of either ATP or ATP[γ S] (19, 22); and (iii) the intermediate species produced in the ATP[γ S]-dependent and ATP-dependent reaction have identical structures as determined by

electron microscopy (unpublished data). Since there are great similarities between the ATP-RecA protein and ATP[γ S]-RecA protein complexes, we believe that the ATP[γ S]-dependent DNA-strand-exchange reaction follows the same mechanistic pathway to joint molecule formation as the ATP-dependent reaction, although the rate-limiting step may have changed.

These data are interesting in light of reports on DNA-strand-transfer activities isolated from organisms other than *E. coli*. The proteins purified from human cells (23) and from *Saccharomyces cerevisiae* (24, 25) have no nucleoside triphosphate requirement. The human protein promotes formation of approximately 200 base pairs of heteroduplex DNA (23) whereas the yeast protein forms approximately 4.1 kb (24). The latter is similar to the amount formed by RecA protein in the presence of ATP[γ S]. Thus the apparent paradox that eukaryotic proteins can promote DNA heteroduplex formation in the absence of a nucleoside triphosphate can be reconciled by suggesting that the eukaryotic proteins are functionally equivalent to the ATP-bound form of RecA protein. It is possible that in higher organisms, DNA-strand-transfer (ATP not required) and catalytic-turnover (ATP required) activities are physically separated into different polypeptides. Thus, for the human and yeast recombination systems, other protein factors (presumably energy requiring) may be necessary to promote catalytic turnover (dissociation) of the transferase activity, thereby permitting elongation of the DNA heteroduplex regions formed initially. It will be interesting to see if such activities can be isolated in the future.

We thank Drs. Dan Camerini-Otero and Peggy Hsieh for their many interesting and helpful discussions about these results and Linda Roman, Polly Lavery, Angela Eggeston, Bill Rehrauer, and Dan Dixon for their critical reading of this manuscript. This research was funded by grants from the National Institutes of Health to S.C.K. (AI-18987) and D.G.B. (RR-05583).

- Gonda, D. K. & Radding, C. M. (1983) *Cell* **34**, 647-654.
- Kowalczykowski, S. C. (1987) *Trends Biochem. Sci.* **12**, 141-145.
- Cox, M. M. & Lehman, I. R. (1981) *Proc. Natl. Acad. Sci. USA* **78**, 3433-3437.
- Riddles, P. W. & Lehman, I. R. (1985) *J. Biol. Chem.* **260**, 170-173.
- Honigberg, S. M., Gonda, D. K., Flory, J. & Radding, C. M. (1985) *J. Biol. Chem.* **260**, 11845-11851.
- Uhlen, B. E. & Clark, A. J. (1981) *J. Bacteriol.* **148**, 386-390.
- Griffith, J. & Shores, C. G. (1985) *Biochemistry* **24**, 158-162.
- Messing, J. (1983) *Methods Enzymol.* **101**, 20-78.
- Lanzetta, P. A., Alvarez, L. J., Reinach, P. S. & Candia, O. A. (1979) *Anal. Biochem.* **100**, 95-97.
- Weinstock, G. M., McEntee, K. & Lehman, I. R. (1981) *J. Biol. Chem.* **256**, 8850-8855.
- Griffith, J. D. & Formosa, T. (1985) *J. Biol. Chem.* **260**, 4484-4491.
- Cox, M. M. & Lehman, I. R. (1982) *J. Biol. Chem.* **257**, 8523-8532.
- Roman, L. J. & Kowalczykowski, S. C. (1986) *Biochemistry* **25**, 7375-7385.
- Cox, M. M., Pugh, B. F., Schutte, B. C., Lindsley, J. E., Lee, J. & Morrical, S. W. (1987) *DNA Replication and Recombination*, eds. McMacken, R. & Kelly, T. J. (Liss, New York), pp. 595-607.
- Menetski, J. P. & Kowalczykowski, S. C. (1989) *Biochemistry* **28**, 5871-5881.
- Stasiak, A., Stasiak, A. Z. & Koller, T. (1984) *Cold Spring Harbor Symp. Quant. Biol.* **49**, 561-570.
- Register, J. C., III, Christiansen, G. & Griffith, J. (1987) *J. Biol. Chem.* **262**, 12812-12820.
- Schutte, B. C. & Cox, M. M. (1987) *Biochemistry* **26**, 5616-5625.
- Menetski, J. P. & Kowalczykowski, S. C. (1985) *J. Mol. Biol.* **181**, 281-295.
- Menetski, J. P. & Kowalczykowski, S. C. (1987) *J. Biol. Chem.* **262**, 2085-2092.
- Egelman, E. H. & Stasiak, A. (1986) *J. Mol. Biol.* **191**, 677-697.
- Menetski, J. P., Varghese, A. & Kowalczykowski, S. C. (1988) *Biochemistry* **27**, 1205-1212.
- Hsieh, P., Meyn, M. S. & Camerini-Otero, R. D. (1986) *Cell* **44**, 885-894.
- Kolodner, R., Evans, D. H. & Morrison, P. T. (1987) *Proc. Natl. Acad. Sci. USA* **84**, 5560-5564.
- Sugino, A., Nitiss, J. & Resnick, A. M. (1988) *Proc. Natl. Acad. Sci. USA* **85**, 3683-3687.