

# Cell-permeable iron inhibits vascular endothelial growth factor receptor-2 signaling and tumor angiogenesis

## Supplementary Materials

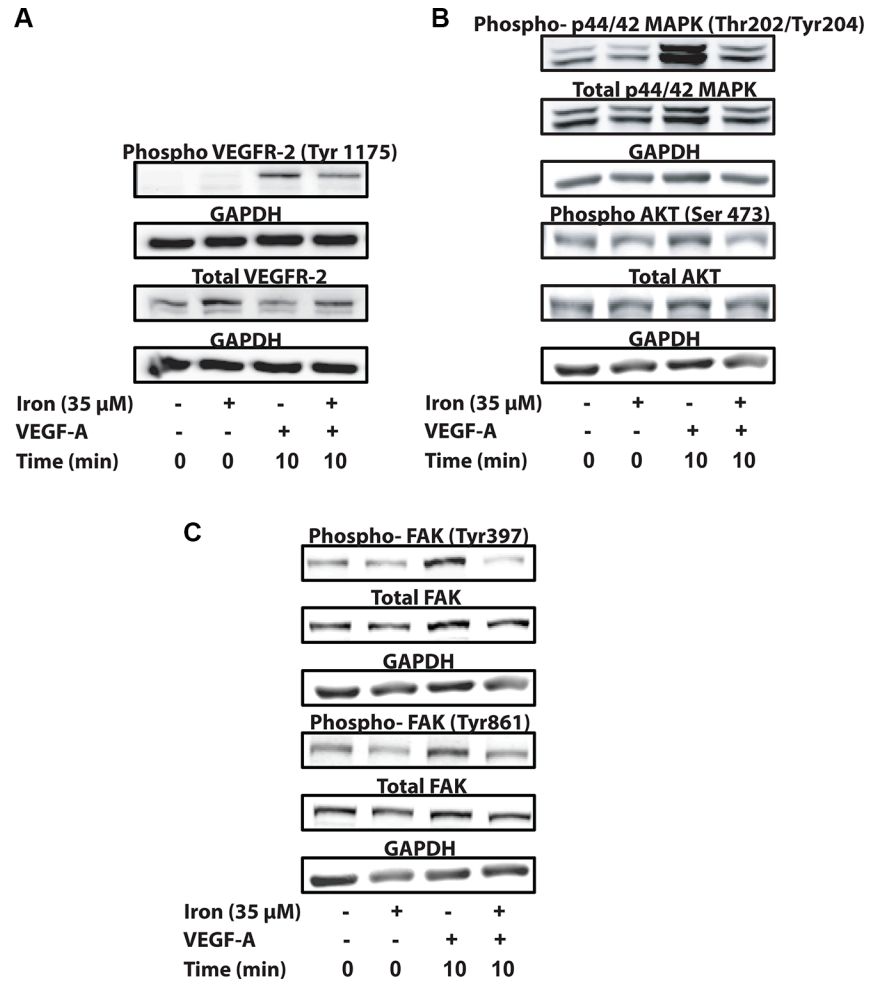

Supplementary Figure S1: Representative immunoblots of HUVEC stimulated with VEGF-A (100 ng/ml) for 10 min in the presence of 35 μM iron are shown.

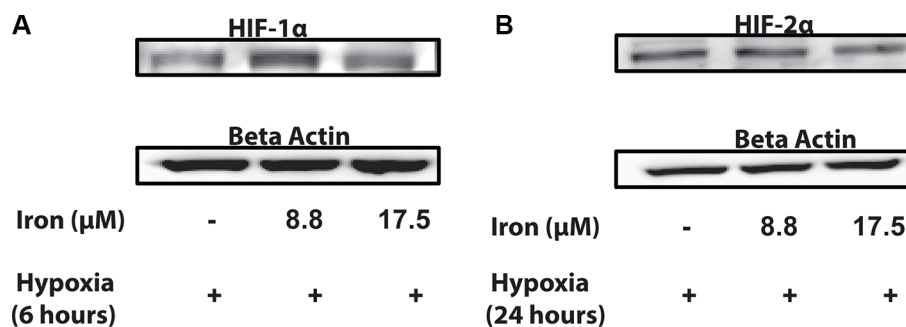

Supplementary Figure S2: Representative HIF-1α and HIF-2α immunoblots of HUVEC exposed to hypoxia in the presence of 8.8 μM and 17.5 μM iron for 6 and 24 hours respectively are shown.