

(A) Reactome pathway
 "Negative regulators of
 RIG I and MDA5 signaling"

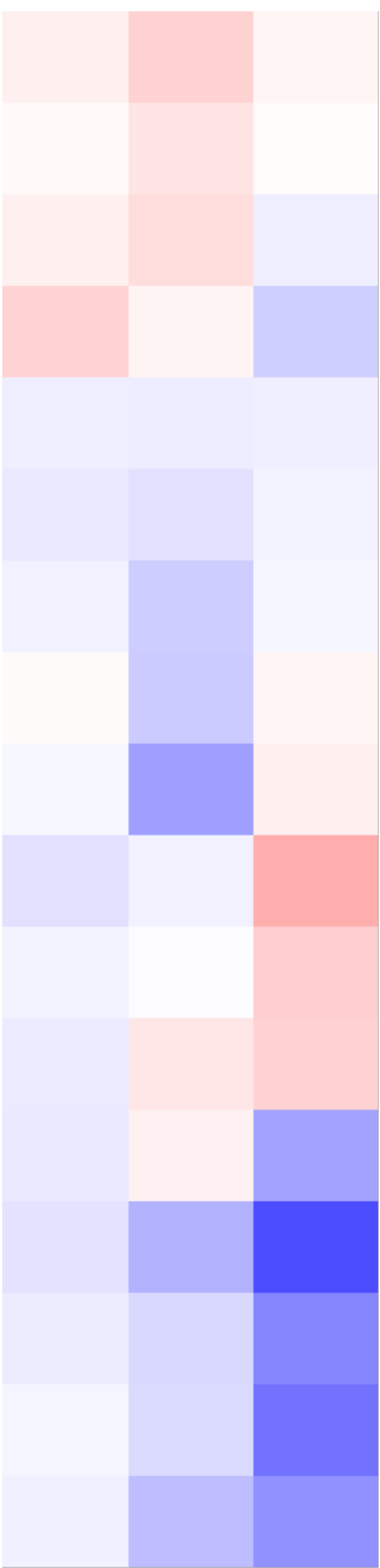

(B) Reactome pathway
 "Antiviral mechanism by
 IFN stimulated genes"

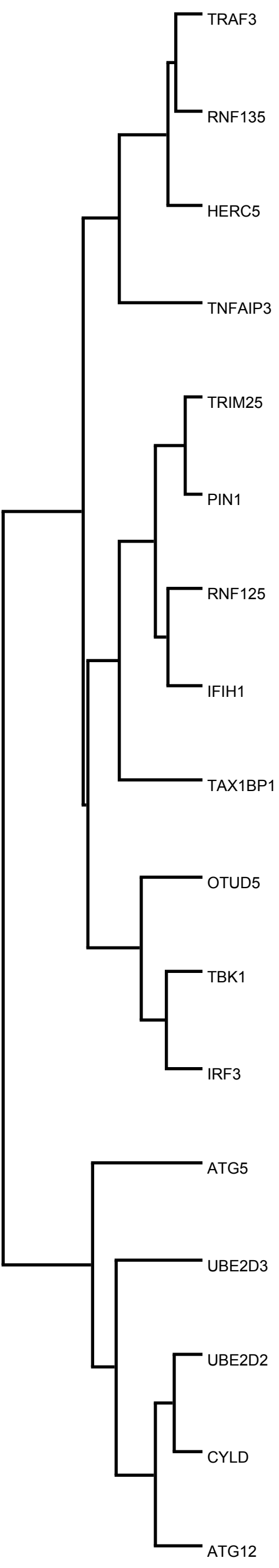
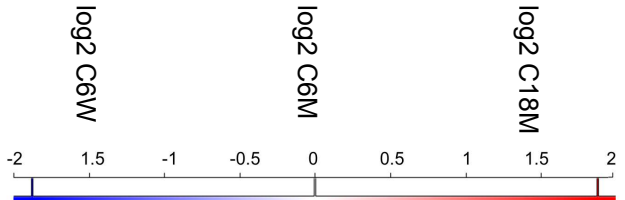
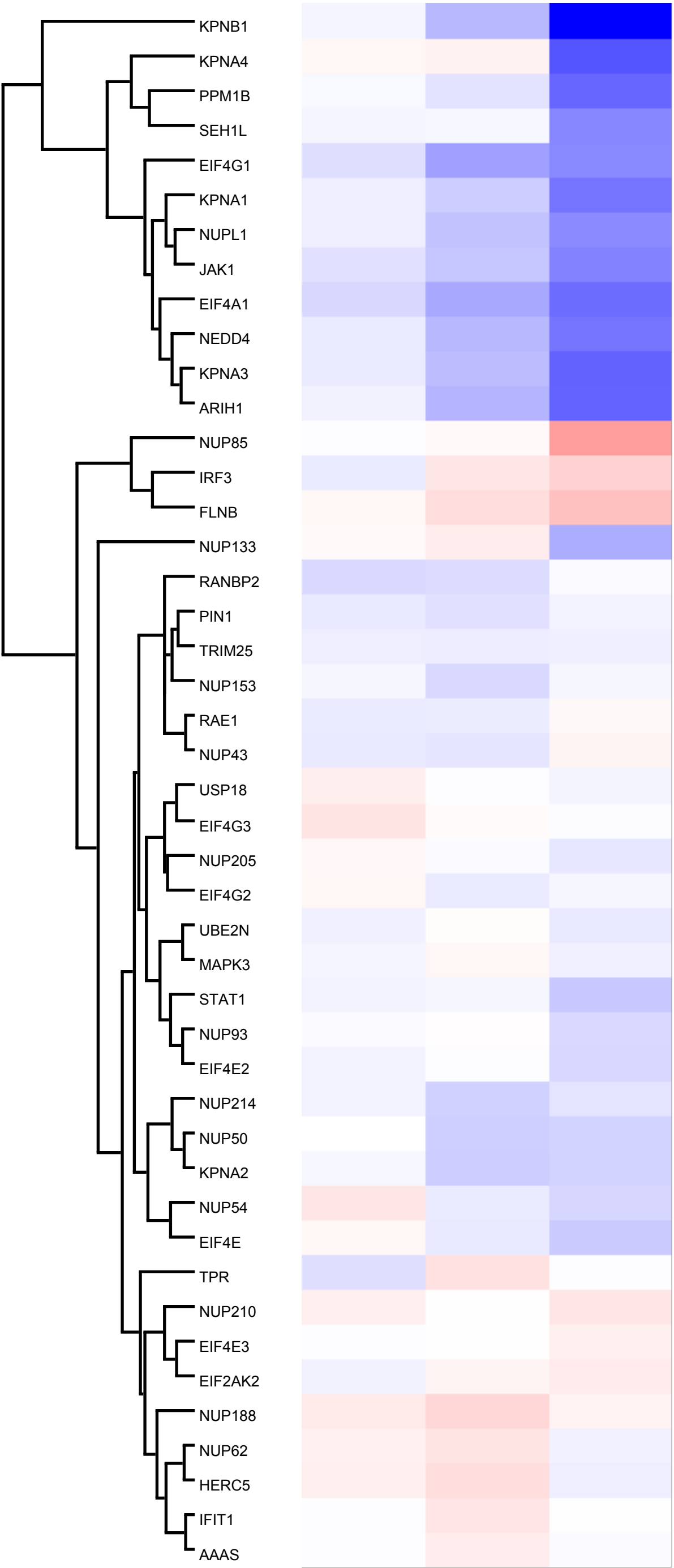
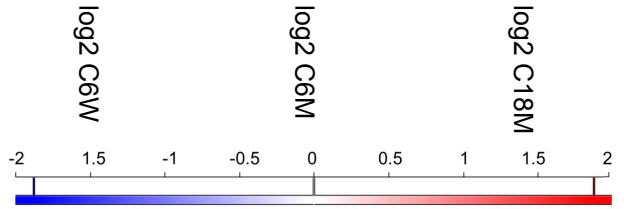

(C) Reactome pathway
 "Antigen processing
 ubiquitination
 proteasome degradation"

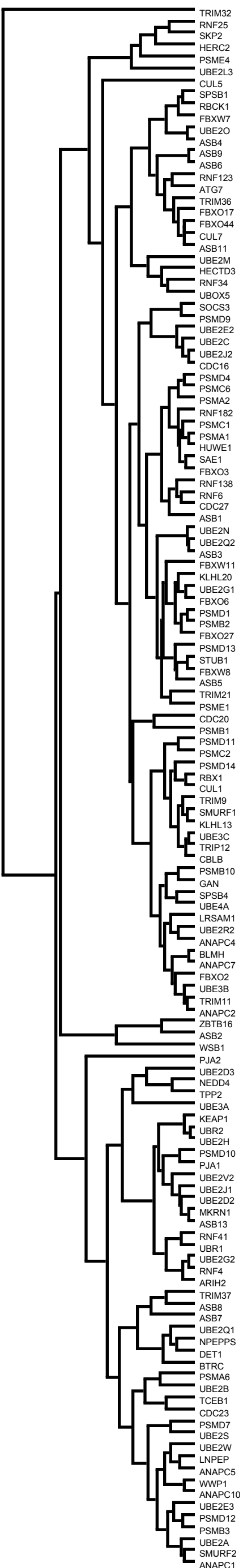
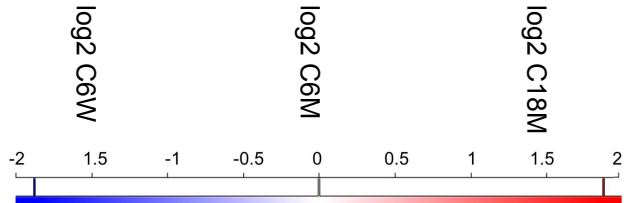

(D) Reactome pathway
 "Activation of chaperone genes
 by Xbp1s"

