

## SPECTRAL DIAGNOSTICS

SDI-PMX-NA001

### **EUPHRATES TRIAL**

**E**valuating the **U**se of **P**olymyxin B **H**emoperfusion

in a **R**andomized Controlled Trial of **A**dults

**T**reated for **E**ndotoxemia and **S**eptic Shock

This confidential document is the property of Spectral Diagnostics and it is provided for the use of the investigator and other designated personnel solely in connection with the conduct of the study described herein. No information contained herein may be disclosed, except as necessary to obtain consent from persons who are considering participation in the study, without prior written approval of Spectral Diagnostics.

**Current Version: 9.1**

**Date: 11Aug2015**

Evaluating the Use of Polymyxin B Hemoperfusion in a Randomized controlled trial of Adults Treated for Endotoxemia and Septic shock

**Protocol Number:** SDI-PMX-NA001

**Protocol Version:** Version 9.1

**Date:** 11August2015

**Medical Monitor:** Shide Badri, MD  
Amarex, LLC  
20201 Century Boulevard  
Germantown, MD USA 20874  
Phone: 240-454-6825  
Fax: 240-813-2868  
Email: shideb@amarexcro.com

**Sponsor:** Spectral Diagnostics (US), Inc.  
20201 Century Boulevard, Ste 450  
Germantown, MD USA 20874  
Phone: 301-528-7000  
Fax: 301-528-2300

**Previous Protocol Versions:** **Version 1, July 30, 2009**  
**Version 2, October 30, 2009**  
**Version 3, December 30, 2009**  
**Version 4, January 30, 2010**  
**Version 5, July 1, 2011**  
**Version 6, January 1, 2012**  
**Version 7, April 27, 2012(not distributed to sites)**  
**Version 7.1, June 26, 2012**  
**Version 8, August 8, 2012**  
**Version 9, April 28, 2014**

## 1 Protocol Synopsis

<p><b>Study Title:</b></p> <p>Evaluating the Use of Polymyxin B Hemoperfusion in a Randomized Controlled Trial of Adults Treated for Endotoxemia and Septic Shock.</p>
<p><b>Study Number and Acronym:</b></p> <p>SDI-PMX-NA001</p> <p>EUPHRATES</p>
<p><b>Primary Objectives:</b></p> <p>To compare the safety and efficacy of the PMX cartridge based on mortality at 28-days in subjects with septic shock who have high levels of endotoxin and are treated with standard medical care plus use of the PMX cartridge, versus subjects who receive standard medical care alone.</p>
<p><b>Secondary Objectives:</b></p> <ol style="list-style-type: none"> <li>1. To compare mortality between the two groups at 90 days, 6 months and 12 months post-start of treatment</li> <li>2. To compare the change in endotoxin levels between the PMX cartridge treated group and the control group at 12 hours after completion of a second PMX cartridge, with a treatment target of a <math>\geq 15\%</math> reduction of EAA levels with PMX cartridge treatment</li> <li>3. To compare the changes in vasopressor doses for the two groups from Day 0 to Day 3</li> <li>4. To compare the number of days of need for vasopressors in each group from Day 0 to Day 28 (days alive and off vasopressors)</li> <li>5. To compare changes in mean arterial blood pressure (MAP) for the two groups from Day 0 to Day 3</li> <li>6. Comparison of the changes in renal function from day 0 to Day 3:             <ol style="list-style-type: none"> <li>i. Urine output</li> <li>ii. Serum creatinine</li> </ol> </li> <li>7. To compare the effects of two uses of the PMX cartridge on progression of, and recovery from, organ dysfunction using the Multiple Organ Dysfunction Score (MODS) from Day 0 to Day 3</li> <li>8. To compare the number of days of need for renal replacement therapy (RRT) in each group from Day 0 to Day 28 (days alive and off RRT)</li> <li>9. To compare the number of days of need for mechanical ventilation (MV) in each group from Day 0 to Day 28 (days alive and off MV)</li> </ol>

<p>10. To compare the mean number of days spent in the hospital by subjects in each group for survivors to Day 28</p> <p>11. To compare survival time from baseline to death within 28 days and compare the risk of death between the two study arms</p> <p>12. To compare survival time from baseline to death within 90 days and compare the risk of death between the two study arms</p>
<p><b>Study Phase:</b></p> <p>Phase III</p>
<p><b>Number of Centers:</b></p> <p>Approximately 60 in the USA and Canada</p>
<p><b>Number of Subjects:</b></p> <p>Approximately 478 (239 per treatment arm)</p>
<p><b>Study Design:</b></p> <p>Double-blinded, randomized, controlled trial of standard care plus the PMX cartridge versus standard of care alone.</p>
<p><b>Investigational Device:</b></p> <p>The TORAYMYXIN PMX-20R (PMX cartridge) is a single use extracorporeal hemoperfusion device to remove endotoxin from patients' blood through direct hemoperfusion (DHP).</p> <p>The PMX cartridge was approved for use in Japan in 1993, in the EU in 1998 and in Canada in 2003.</p>
<p><b>Treatment Intervention:</b></p> <p>Two (2) PMX cartridges will be administered approximately 24 hours apart. Each treatment will target 2 hours with a minimum of 1 ½ hours, at a flow rate of approximately 100 ml/minute, (range of 80 to 120 ml/minute).</p> <p>The treatment and control arm of the study will include standard medical care for septic shock which will include fluid replacement, vasopressor infusion, antimicrobials and ventilator support or renal replacement therapy if necessary.</p>
<p><b>Patient Population:</b></p> <p>Intensive Care Unit subjects with septic shock and endotoxemia.</p>

**Inclusion Criteria:**

Subjects who meet the following criteria (and have a signed informed consent) will be allowed into the study:

1. Age  $\geq 18$  years of age
2. Hypotension requiring vasopressor support: Requirement for at least one of the vasopressors listed below, at the dose shown below, for *at least* 2 continuous hours and no more than 30 hours\*
  - a. Norepinephrine  $> 0.05$  mcg/kg/min
  - b. Dopamine  $> 10$  mcg/kg/min
  - c. Phenylephrine  $> 0.4$  mcg/kg/min
  - d. Epinephrine  $> 0.05$  mcg/kg/min
  - e. Vasopressin  $> 0.03$  units/min
  - f. Vasopressin (any dose) in combination with another vasopressor listed above
3. The subject must have received intravenous fluid resuscitation of a minimum of 30mL/kg administered within 24 hours of eligibility
4. Documented or suspected infection defined as definitive or empiric intravenous antibiotic administration
5. Endotoxin Activity Assay  $\geq 0.60$  EAA units
6. Evidence of at least 1 of the following criteria for new onset organ dysfunction that is considered to be due to the acute illness
  - a. Requirement for positive pressure ventilation via an endotracheal tube or tracheostomy tube
  - b. Thrombocytopenia defined as acute onset of platelet count  $< 150,000$   $\mu$ /L or a reduction of 50% from prior known levels
  - c. Acute oliguria defined as urine output  $< 0.5$  ml/kg/hr for at least 6 hours despite adequate fluid resuscitation

**Exclusion Criteria:**

1. Inability to obtain an informed consent from the subject, family member or an authorized surrogate

\* When determining the eligible dose of vasopressors for a subject whose measured body weight is  $>100$  kg, the maximum weight of 100 kg (220 lbs) will be used. This maximum weight applies to both males and females.

2. Lack of commitment for full medical support
3. Inability to achieve or maintain a minimum mean arterial pressure (MAP) of  $\geq 65$ mmHg despite vasopressor therapy and fluid resuscitation
4. Subject has end stage renal disease and requires chronic dialysis
5. There is clinical support for non-septic shock such as
  - a. Acute pulmonary embolus
  - b. Transfusion reaction
  - c. Severe congestive heart failure (e.g. NYHA Class IV, ejection fraction  $< 35\%$ ) \*
6. Subject has had chest compressions as part of CPR this hospitalization without immediate return to communicative state
7. Subject has had an acute myocardial infarction (AMI) within the past 4 weeks
8. Subject has uncontrolled hemorrhage (acute blood loss requiring  $> 3$  UPC in the past 24 hours)
9. Major trauma within 36 hours of screening
10. Subject has severe granulocytopenia (leukocyte count less than 500 cells/mm<sup>3</sup>) or severe thrombocytopenia (platelet count less than 30,000 cells/mm<sup>3</sup>)
11. HIV infection in association with a last known or suspected CD4 count of  $< 50$ /mm<sup>3</sup>
12. Subject's baseline state is non-communicative
13. Subject has sustained extensive third-degree burns within the past 7 days
14. Body weight  $< 35$  kg (77 pounds)
15. Known hypersensitivity to Polymyxin B
16. Subject has known sensitivity or allergy to heparin or has a history of heparin associated thrombocytopenia (H.I.T.)
17. Subject is currently enrolled in an investigational drug or device trial
18. Subject has been previously enrolled in the current trial
19. Any other condition, that in the opinion of the investigator, would preclude the subject from being a suitable candidate for enrollment, such as end stage chronic illness with no reasonable expectation of survival to hospital discharge
20. Subject has a screening MOD score  $\leq 9$

---

\* Please note that an ejection fraction of  $< 35\%$  does not automatically exclude the subject. This ejection fraction example is intended to describe chronic severe congestive heart failure NYHA Class IV only.

**Study Procedures:**

This is a double-blind, randomized, controlled trial of standard medical care plus the PMX cartridge versus standard medical care alone in subjects with endotoxemia and septic shock. Subjects in ICUs will be assessed for septic shock using known or suspected infection and hypotension requiring vasopressor support as primary criteria. Subjects will meet all entry criteria for study except EAA activity  $\geq 0.60$ . Subjects (or surrogate decision maker) will then be consented to a blood draw to determine the presence of an elevated endotoxin level ( $\geq 0.60$  EAA units) using the Endotoxin Activity Assay (EAA™).

If the EAA is elevated ( $\geq 0.60$  EAA units), the subjects or their surrogate will be approached for consent, the full inclusion/exclusion criteria will continue to be met, as determined in conjunction with the Clinical Coordination Center, and enrollment in the trial and, if achieved, randomized to receive either standard medical care for septic shock or standard medical care plus the PMX cartridge (administered twice for 1½ to 2 hours per cartridge approximately 24 hours apart). The status of all subjects will be followed by clinicians using standard procedures with EAA measurements performed during the first 72 hours. After 72 hours, subjects will have detailed assessments on Day 7, and then at weekly intervals through Day 28 (+1/- 6 days) while in the hospital for efficacy and safety clinical assessments. If subjects are discharged from the hospital prior to Day 28, the End of Study/Early Termination (Day 28) assessments will take place at discharge with telephone assignment at Day 28. For all subjects, a follow-up visit or telephone call to determine their mortality status will take place approximately three months (i.e., Day 90) and at 6 months and 12 months after the subject is randomized.

To maintain the trial's blind, the ICU physician investigators, those health care professionals involved in recording blinded data, and those who are involved in data analysis (except an independent statistician), will remain blinded to allocation of treatment.

A nephrology staff member, the ICU bedside nurse, and a pharmacist will know the treatment allocation and be trained to record allocation and treatment records (timing of device use) and concomitant anti-coagulant medication administered (e.g. heparin), onto CRFs that will be kept blinded from the remaining study personnel.

Nephrology staff will be trained to use the PMX cartridge on those subjects randomized to the PMX cartridge group and to maintain the blind for the subjects that are randomized to standard of care by the performing of a sham perfusion. Study staff (PI and other ICU personnel involved in the subjects care) and the subject (and/or the subjects surrogate) will remain blinded to the treatment arm. Pre-study EAA results will be made available to the treating physician, but all subsequent EAA results from Day 0 through Day 28 are to be blinded.

**Study Duration:**

The duration of treatment and active follow-up will be from the time of randomization until 28 days post-randomization. A 90 day, 6 month and 12 month follow-up assessment will be used to determine mortality status. Subjects that are discharged from the hospital prior to

Day 28 will be requested to have End of Study/Early Termination (assessments scheduled for Day 28) assessments at discharge with telephone contact at Day 28.

Study enrollment is expected to be complete in approximately 2016.

**Number of Assessments:**

There are 13 assessments including a primary and secondary screen, Baseline (Day 0), Days 1, 2 and 3, then weekly assessments on Days 7, 14, 21, 28, and follow-up assessments at 90 days, 6 months and 12 months.

**Efficacy Assessments:**

The primary clinical efficacy assessment is mortality at 28 days post-start of treatment.

Other efficacy measures to assess the secondary objectives include assessing in each group of subjects:

- Changes in EAA values
- Changes in the type and dosing of vasopressors used (delta ( $\Delta$ ) cumulative vasopressor index (CVI))
- Changes in renal function (urine volume (ml/hr) and creatinine levels from Baseline to 72 hours)
- Changes in organ status using elements of the MODS (Multiple Organ Dysfunction) score from Baseline to 72 hours
- Number of days the subject is alive and free of the need for:
  - Renal replacement therapy (discontinuation defined as order in chart)
  - Mechanical Ventilation
  - Vasopressors
- Mortality at 90 days, 6 months and 12 months post start of treatment
- To compare the mean number of days spent in the hospital by subjects in each group for survivors to Day 28
- To compare the survival time from baseline to death within 28 days
- To compare the survival time from baseline to death within 90 days



**Safety Assessments:**

- Changes in vital signs
- Changes in blood chemistry and hematology
- Changes in coagulation parameters
- Changes in urinalysis
- Changes in ECGs
- Overall morbidity, plus mortality
- Incidence and severity of adverse events (defined as those categorized into USADEs, SADEs ADEs, SAEs, and AEs)

**Statistics:**

The primary efficacy endpoint is the 28-day mortality rate in subjects with septic shock who have high levels of endotoxin.

Primary safety endpoints are the adverse events, laboratory chemistry, urinalysis and hematology parameters, vital signs, and ECGs. Baseline and longitudinal summary statistics will be provided for both efficacy and safety endpoints at each time point overall as well as by treatment groups (i.e., standard medical care alone or standard medical care plus the PMX cartridge). Continuous variables will be summarized using the number of observations, mean, standard deviation, minimum, lower quartile, median, upper quartile, and the maximum. These statistics will be provided by PROC UNIVARIATE/SAS. Categorical variables will be summarized using the number and percentage in each category.

## 2 Schedule of Assessments

Assessment	Screen <sup>1</sup>		Baseline <sup>2</sup>	Treatment			Post Treatment				Long Term Follow -Up		
	Primary	Secondary	Day 0	Day 1 <sup>10</sup>	Day 2 <sup>11</sup>	Day 3 <sup>12</sup>	Day 7(±1)	Day 14(±1)	Day 21(±1)	Day 28 <sup>6</sup>	Month 3 (±1 Day)	Month 6 (± 7 Days)	Month 12 (± 7 days)
Admission to ICU (date/time)	X												
Informed Consent for EAA	X												
EAA		X		X <sup>3</sup>	X	X <sup>4</sup>	X	X	X	X			
Informed Consent for Randomization		X											
Inclusion/Exclusion Criteria	X	X	X										
Pregnancy Test <sup>8</sup>			X <sup>2</sup>										
Demographics			X										
Medical/Surgical History			X										
Physical Exam			X <sup>2</sup>							X			
Vital Signs <sup>14</sup>			X	X	X	X	X	X	X	X			
12 Lead ECG			X <sup>2</sup>							X			
Microbiology Culture <sup>5</sup>			X	Record any other results collected as part of Standard of Care									
Laboratory Assessments <sup>7</sup>	X		X <sup>2</sup>	X	X	X	X <sup>15</sup>	X <sup>15</sup>	X <sup>15</sup>	X			
Urinalysis			X <sup>2</sup>							X			
Renal function (urine output)			X <sup>2</sup>	X	X	X							
APACHE II Scoring			X <sup>2</sup>										
Organ Function	X			X	X	X							

Assessment	Screen <sup>1</sup>		Baseline <sup>2</sup>	Treatment			Post Treatment				Long Term Follow -Up		
	Primary	Secondary	Day 0	Day 1 <sup>10</sup>	Day 2 <sup>11</sup>	Day 3 <sup>12</sup>	Day 7(±1)	Day 14(±1)	Day 21(±1)	Day 28 <sup>6</sup>	Month 3 (±1 Day)	Month 6 (± 7 Days)	Month 12 (± 7 days)
(MODS) Scoring													
Mechanical Ventilation Use	X		X <sup>2</sup>	X	X	X	X	X	X	X			
Assess RRT Use			X <sup>2</sup>	X	X	X	X	X	X	X			
Vasopressor Use	X	X	X <sup>2</sup>	X	X	X	X	X	X	X			
CVI score			X	X	X	X							
Randomization <sup>9</sup>			X										
PMX Cartridge or Sham				XX									
Mortality Status <sup>13</sup>									X	X	X	X	X
Concomitant Medications	X	X	X	X	X	X	X	X	X	X			
Adverse Events <sup>2</sup>			X	X	X	X	X	X	X	X	X	X	X

- The screening period is defined as the interval of time from 2 hours after onset of vasopressor therapy to the time of randomization
- Baseline is defined as starting at the time of randomization to the initiation of the study perfusion. Assessments for baseline recording can be performed during the primary and secondary screening period, i.e. -12h to initiation of treatment at the exception of the following:
  - Blood cultures may be drawn up to 24 hr prior to randomization, or anytime during baseline
  - Urine output may be collected over a maximum of 24 hr prior to the first treatment
  - Vital signs may be measured within 4hr of randomization.
  - All adverse and safety events begin at dialysis line or SHAM line insertion.
- EAA performed 10 hours (+/- 30 minutes) after the completion of each PMX cartridge administration or sham perfusion
- Blood sample for EAA to be obtained on scheduled days as long as subject remains in hospital. Results after the screening sample are to remain blinded
- Two sets of blood cultures (aerobic and anaerobic for each set) must be drawn for baseline assessment and results recorded in the CRF for baseline (day 0) assessments. Results are not required prior to randomization. Any other microbiology cultures collected as part of Standard of Care from Day 1 to Day 28 will be recorded on the Microbiology Culture results page in the CRF, including those with a report of “no growth”.

6. There is a window of (-6/+1 days) for Assessments for patients alive on Day 28. However, the mortality determination should be done at least 28 days post first treatment or later.
7. Lab assessments include hematology, chemistry and coagulation
8. To be performed on females of childbearing potential
9. Eligibility confirmation conducted through the Cooper Clinical Coordinating Center (C4); randomization is generated through a central source and is conducted through local pharmacies
10. Day 1 will be designated as the 24 hour period from the start of the first treatment to the end of the second treatment (PMX cartridge/sham perfusion)
11. Day 2 is designated as the 24 hours after the second PMX cartridge/sham perfusion has been completed. The Day 2 assessments will take place approximately 10 hours ( $\pm$  2 hours) after the completion of the 2nd PMX cartridge/sham perfusion
12. Day 3 will correspond to the 24 hour interval after Day 2. The Day 3 assessments will be made no earlier than 24 hours after the Day 2 assessments were performed, and no later than the end of Day 3.
13. Mortality status confirmation on day 28 (or later), day 90 ( $\pm$ 1 day) and at 6 month (+/- 7 days and 12 months (+/- 7days) via telephone contact or visit, if subject remains in study hospital
14. O<sub>2</sub> saturation may be obtained from electronic monitor
15. These lab tests are required only if they are the study site/s standard of care and collected within the protocol-specified window (i.e., these labs are not required if they are not the site's standard of care; additionally, these labs are not required if they are standard of care for the site but collected outside the protocol-specified window)

**3 Principal Investigator Signature Page**

PROTOCOL ID: SDI-PMX-NA001

SPONSOR: Spectral Diagnostics, Inc.

STUDY TITLE: Evaluating the Use of Polymyxin B Hemoperfusion in a Randomized Controlled Trial of Adults Treated for Endotoxemia and Septic shock

I have read the protocol and the appendices and agree that it contains all necessary details for carrying out the study as described. I understand the contents and intend to comply fully with all requirements and the applicable current local regulations and guidelines. I will conduct this study as outlined herein, including all statements regarding confidentiality. No changes will be made without formal authorization by Spectral Diagnostics in the form of a protocol amendment. I understand that approval from coordinating center must be obtained prior to patient enrollment.

I will make a reasonable effort to complete the study within the time designated. I will provide copies of the protocol and access to all information furnished by the Sponsor to study personnel under my supervision. I will discuss this material with them to ensure that they are fully informed about the device (PMX cartridge) and the study. I understand that the study may be terminated or enrollment suspended at any time by the Sponsor, with or without cause, or by me if it becomes necessary to protect the best interests of the subjects in the study. I, my co-investigators and the unit directors/ICU physicians where the subjects are enrolled support and where possible, follow the basic tenets of the 2012 Surviving Sepsis Campaign Guidelines on the Management of Severe Sepsis and Septic Shock.

I agree to conduct this study in full accordance with all applicable regulations and ICH/Good Clinical Practice (GCP).

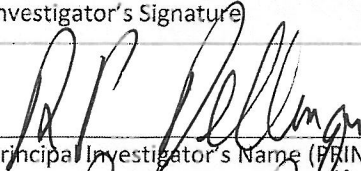
Investigator's Signature	Date
	8/13/15
Principal Investigator's Name (PRINT)	
RP Dellinger	

**4 Investigator Signature Page****PROTOCOL ID:** SDI-PMX-NA001**SPONSOR:** Spectral Diagnostics, Inc.**STUDY TITLE:** Evaluating the Use of Polymyxin B Hemoperfusion in a Randomized Controlled Trial of Adults Treated for Endotoxemia and Septic shock

I have read the protocol and the appendices and agree that it contains all necessary details for carrying out the study as described. I understand the contents and intend to comply fully with all requirements and the applicable current local regulations and guidelines. I will conduct this study as outlined herein, including all statements regarding confidentiality. No changes will be made without formal authorization by Spectral Diagnostics in the form of a protocol amendment. I understand that approval from coordinating center must be obtained prior to patient enrollment.

I will make a reasonable effort to complete the study within the time designated. I will provide copies of the protocol and access to all information furnished by the Sponsor to study personnel under my supervision. I will discuss this material with them to ensure that they are fully informed about the device and the study. I understand that the study may be terminated or enrollment suspended at any time by the Sponsor, with or without cause, or by me if it becomes necessary to protect the best interests of the subjects in the study.

I agree to conduct this study in full accordance with all applicable regulations and ICH/Good Clinical Practice (GCP).

Investigator's Signature	Date
Investigator's Name (PRINT)	

## 5 Medical Monitor Signature Page

**PROTOCOL ID:** SDI-PMX-NA001

**SPONSOR:** Spectral Diagnostics, Inc.

**STUDY TITLE:** Evaluating the Use of Polymyxin B Hemoperfusion in a Randomized Controlled Trial of Adults Treated for Endotoxemia and Septic shock

I have read the protocol and the appendices and agree that it contains all necessary details for carrying out the study as described. I understand the contents and intend to comply fully with all requirements and the applicable current local regulations and guidelines. I will conduct this study as outlined herein, including all statements regarding confidentiality. No changes will be made without formal authorization by Spectral Diagnostics in the form of a protocol amendment.

Medical Monitor's Signature	Date
	12 Aug 2015
Medical Monitor's Name (PRINT)	
Shide Badri, MD	

**6 Sponsor Signature Page****PROTOCOL ID:** SDI-PMX-NA001**SPONSOR:** Spectral Diagnostics, Inc.**STUDY TITLE:** Evaluating the Use of Polymyxin B Hemoperfusion in a Randomized Controlled Trial of Adults Treated for Endotoxemia and Septic shock

I have read the protocol and the appendices and agree that it contains all necessary details for carrying out the study as described. I understand the contents and intend to have Spectral Diagnostics, Inc. comply fully with all requirements and the applicable current local regulations and guidelines. Any changes in the protocol will only be implemented after with formal authorization and approval of appropriate ethic committees and by Spectral Diagnostics in the form of a protocol amendment.

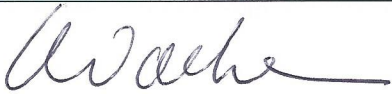
Sponsor's Signature	Date
	Aug 11/2015
Sponsor's Name (PRINT)	
PAUL WANKER	



## **7 Table of Contents**

<b>1</b>	<b>Protocol Synopsis .....</b>	<b>3</b>
<b>2</b>	<b>Schedule of Assessments .....</b>	<b>10</b>
<b>3</b>	<b>Principal Investigator Signature Page .....</b>	<b>13</b>
<b>4</b>	<b>Investigator Signature Page .....</b>	<b>14</b>
<b>5</b>	<b>Medical Monitor Signature Page .....</b>	<b>15</b>
<b>6</b>	<b>Sponsor Signature Page .....</b>	<b>16</b>
<b>7</b>	<b>Table of Contents .....</b>	<b>17</b>
7.1	Table of Figures:.....	22
<b>8</b>	<b>Contact Details .....</b>	<b>23</b>
<b>9</b>	<b>List of Abbreviations and Definition of Terms.....</b>	<b>24</b>
<b>10</b>	<b>Introduction .....</b>	<b>26</b>
10.1	Background .....	26
10.2	Disease Background/Diagnosis .....	27
10.2.1	<i>Mortality .....</i>	<i>27</i>
10.2.2	<i>Septic Shock.....</i>	<i>27</i>
10.3	Preclinical and Toxicology Studies .....	28
10.4	Human Clinical Studies.....	28
10.4.1	<i>Contraindications.....</i>	<i>30</i>
10.4.2	<i>Precautions Relating To Heparin Administration During PMX Treatment.....</i>	<i>30</i>
10.4.3	<i>Potential Adverse Events Identified in Clinical Studies.....</i>	<i>31</i>
10.4.4	<i>Potential Adverse Reactions with Polymyxin B.....</i>	<i>31</i>
10.4.4.1	<b>Drug to Drug Interactions with Polymyxin B:.....</b>	<b>32</b>
10.4.4.2	<b>Adverse Drug Reactions with intravenous Polymyxin B:.....</b>	<b>32</b>
10.4.4.3	<b>Precautions related to dialysis catheter line insertion and presence during PMX treatment.....</b>	<b>32</b>
<b>11</b>	<b>Study Objectives.....</b>	<b>32</b>
11.1	Primary Objective .....	32
11.2	Secondary Trial Objectives:.....	32
<b>12</b>	<b>Investigational Plan .....</b>	<b>33</b>

12.1 Overview of Study Procedures.....	33
12.2 Number of Subjects .....	34
12.3 Study Centers.....	34
12.3.1 Cooper Clinical Coordinating Center (C4).....	34
12.4 Study Population and Selection Criteria .....	34
12.4.1 Study Population .....	34
12.4.2 Inclusion Criteria .....	35
12.4.3 Exclusion Criteria.....	36
12.5 Study Treatments.....	37
12.5.1 Standard of Care Treatment .....	37
12.5.2 Prohibited Medications.....	37
12.6 Treatment Randomization .....	37
12.6.1 Methods of Assigning Subjects to Treatment Groups.....	37
12.6.2 Randomization Schedule.....	37
12.6.3 Blinding .....	38
<b>13 Investigational Device (PMX Cartridge) Overview.....</b>	<b>40</b>
13.1 Investigational Device (PMX Cartridge) Names .....	40
13.1.1 Generic name: PMX cartridge .....	40
13.1.2 Trade name: TORAYMYXIN PMX-20R Extracorporeal Hemoperfusion Cartridge 40	
13.2 Investigational Device (PMX Cartridge) Physical and Chemical Characteristics .....	40
13.3 Labeling and Packaging of PMX Cartridges.....	41
13.4 Sham Carton.....	43
13.5 Required Documents Prior to 1st PMX Cartridge and Sham Carton Shipment:.....	43
13.6 Summary of Investigational Device Use (Perfusion).....	43
13.7 PMX Cartridge and Sham Carton Shipping, Storage, Preparation, and Handling Instructions .....	44
13.7.1 Investigational Device, Accountability and Reconciliation.....	44
<b>14 Study Outline and Visit Assessments.....</b>	<b>45</b>
14.1 Informed Consent Processes .....	45
14.2 Subject Identification .....	46
14.3 Subject Screening Overview .....	46

14.3.1	<i>Overview of Screening</i> .....	46
14.3.2	<i>Screening Process</i> .....	47
14.3.3	<i>Screen Failures (eligible subjects with EAA consent and/or known EAA value)</i> .....	48
14.3.4	<i>Standardizing essential treatments of sepsis</i> .....	48
14.3.5	<i>Baseline Assessments</i> .....	49
14.4	<b>Day 1 Processes and Assessments</b> .....	50
14.4.1	<i>Schematic Day 1 Processes and Assessments</i> .....	50
14.4.2	<i>First PMX Cartridge (or Sham) Treatment</i> .....	50
14.4.3	<i>Day 1 Safety and Efficacy Assessments</i> .....	51
14.4.4	<i>Second PMX Cartridge (or Sham) Treatment</i> .....	52
14.5	<b>Day 2: Procedures and Assessments</b> .....	52
14.5.1	<i>Day 2 Safety and Efficacy Assessments:</i> .....	53
14.6	<b>Day 3 Procedures and Assessments</b> .....	54
14.6.1	<i>Day 3 Safety and Efficacy Assessments</i> .....	54
14.7	<b>Day 7, Day 14 and Day 21 Assessments</b> .....	54
14.8	<b>End of Study/Early Termination (Day 28) Assessments</b> .....	55
14.9	<b>Follow-Up Visit Assessments – 90 days (<math>\pm 1</math> day), 6 Months (<math>\pm 7</math> days) and 12 Months (<math>\pm 7</math> days)</b> .....	56
14.10	<b>Follow-Up - Hospitalization/Discharge Beyond 12 months</b> .....	56
<b>15</b>	<b>Overview of Visit Assessments</b> .....	<b>56</b>
15.1	<b>Endotoxin Activity Assay (EAA)</b> .....	56
15.2	<b>Microbiology Culture Reports</b> .....	56
15.3	<b>Acute Physiology and Chronic Health Evaluation (APACHE II) score</b> .....	57
15.4	<b>Multiple Organ Dysfunction Syndrome (MODS)</b> .....	57
15.5	<b>Acute Kidney Injury Network (AKIN) scoring system</b> .....	58
15.6	<b>Mechanical Ventilation (MV)</b> .....	58
15.7	<b>Renal Replacement Therapy (RRT)</b> .....	59
15.8	<b>Vasopressor and Cumulative Vasopressor Index (CVI)</b> .....	59
15.9	<b>Medical History</b> .....	60
15.9.1	<i>Concurrent Medical Conditions and Past Medical History</i> .....	60
15.9.2	<i>Documentation of Septic Shock</i> .....	60
15.9.3	<i>Documentation of Infection</i> .....	60

15.10	Physical Examination.....	61
15.11	Vital Signs .....	61
15.12	Electrocardiograms (ECG) .....	61
15.13	Laboratory Assessments .....	61
15.13.1	<i>Hematology/Chemistry/Coagulation</i> .....	62
15.13.2	<i>Urinalysis</i> .....	62
15.13.3	<i>Pregnancy Test</i> .....	62
15.13.4	<i>Biohazard Containment</i> .....	62
15.14	Mortality Status and Disposition .....	63
<b>16</b>	<b>Efficacy and Safety Outcomes .....</b>	<b>63</b>
<b>17</b>	<b>Safety Information.....</b>	<b>64</b>
17.1	Warnings and Precautions .....	64
17.2	Pre-treatment Conditions .....	64
17.3	Definitions Adverse Events (AE) and Serious Adverse Events (SAE):.....	64
17.3.1	<i>Definition of an Adverse Event (AE)</i> .....	64
17.3.2	<i>Definition of a Serious Adverse Event (SAE)</i> .....	64
17.3.3	<i>Definition of Serious Adverse Device Effects (SADE)</i> .....	65
17.3.4	<i>Definition of Unanticipated Serious Adverse Device Event (USADE)</i> .....	65
17.4	Collection of Safety Events .....	65
17.5	Documenting Safety Events .....	66
17.6	Follow-Up of Safety Events .....	67
17.7	Prompt Reporting of Safety Events to Sponsor .....	67
17.7.1	<i>Regulatory Reporting Requirements for Sponsors</i> .....	68
<b>17.7.1.1</b>	<b>Unanticipated Serious Adverse Device Effects</b> .....	<b>68</b>
<b>17.7.1.2</b>	<b>Withdrawal of IRB Approval</b> .....	<b>68</b>
<b>17.7.1.3</b>	<b>Withdrawal of FDA Approval</b> .....	<b>68</b>
<b>17.7.1.4</b>	<b>Current List of Investigators</b> .....	<b>68</b>
<b>17.7.1.5</b>	<b>Progress Reports (or Annual Reports)</b> .....	<b>68</b>
<b>17.7.1.6</b>	<b>Recalls and Device Disposition</b> .....	<b>68</b>
<b>17.7.1.7</b>	<b>Final Report</b> .....	<b>69</b>

<b>17.7.1.8</b>	<b>Informed consent</b> .....	69
<b>17.7.1.9</b>	<b>IRB Significant Risk Device Determination</b> .....	69
17.8	Emergency Procedures .....	69
17.8.1	<i>Emergency Unblinding</i> .....	69
<b>18</b>	<b>Premature Termination of Treatment</b> .....	<b>69</b>
18.1	Study Discontinuation.....	69
18.2	Withdrawn for Safety.....	70
18.3	Sponsor’s Actions.....	70
<b>19</b>	<b>Statistical Considerations</b> .....	<b>70</b>
19.1	Data Collection and Management .....	70
19.2	Sample Size Determination.....	71
19.3	Definition of Study Population for Analysis .....	71
19.4	Comparability of Subjects at Baseline .....	72
19.5	Efficacy Variables and Analysis .....	72
19.6	Safety Data .....	75
19.6.1	<i>Routine Monitoring of the Trial’s Status:</i> .....	75
19.7	Missing data .....	75
19.8	Sequence of Planned Analyses .....	76
19.8.1	<i>Interim Analyses</i> .....	76
19.8.2	<i>Final Analysis and Reporting</i> .....	76
<b>20</b>	<b>Administrative Aspects</b> .....	<b>77</b>
20.1	Data Quality Assurance.....	77
20.2	Institutional Review Board (IRB) Approval.....	77
20.3	Independent Ethics Committee or Institutional Review Board .....	78
20.4	Ethical Conduct of the Study.....	78
20.5	Subject Information and Informed Consent .....	78
20.6	Removal of subjects from treatment or assessment.....	79
20.7	Case Report Forms.....	80
20.8	Adverse Event Reporting .....	80
20.9	Monitoring of the Study.....	80
20.10	Review of Source Records.....	81

20.11	Protocol Amendments .....	81
20.12	Change in Investigator .....	82
20.13	Confidentiality.....	82
20.14	Disclosure Statement.....	82
20.15	Records Retention.....	83
20.15.1	<i>Sample Retention</i> .....	83
20.16	Publications.....	83
20.17	Subject Injury .....	83
<b>21</b>	<b>References.....</b>	<b>84</b>
<b>22</b>	<b>Appendices.....</b>	<b>86</b>

#### 7.1 Table of Figures:

Figure 1.	Diagram of PMX Cartridge .....	40
Figure 2.	PMX Cartridge Label.....	42
Figure 3:	Perfusion Schematic for the PMX Cartridge .....	44
Figure 4.	Schematic Day 1 .....	50
Figure 5.	Schematic of Day 2.....	53

## 8 Contact Details

SPONSOR	COOPER CLINICAL COORDINATING CENTER (C4)	CONTRACT RESEARCH ORGANIZATION (CRO)	LEAD INVESTIGATOR
<p><b>Spectral Diagnostics, Inc.</b></p> <p>CANADIAN OFFICE: 135 The West Mall Toronto, Ontario M9C1C2, Canada Phone: 416-626-3233 Fax: 416-626-7383</p> <p>US OFFICE: Spectral Diagnostics (US) Inc. 20201 Century BoulevardSte 450 Germantown, MD 20874 Phone: 301-528-7000 Fax: 301-528-2300</p> <p><a href="http://www.spectraldx.com">www.spectraldx.com</a></p>	<p><b>Cooper Health System</b></p> <p>One Cooper Plaza Camden, NJ 08103</p>	<p><b>Amarex</b></p> <p>20201 Century Boulevard Ste 450 Germantown, MD, 20874</p> <p>Phone: 301-528-7000 FAX: 301-528-2300</p> <p><a href="http://www.amarexcro.com">www.amarexcro.com</a></p>	<p><b>R. Phillip Dellinger, MD</b></p> <p>Cooper Health System One Cooper Plaza Camden, NJ 08103</p> <p>Phone: 856-342-2632</p>

### Responsible Spectral Diagnostics, Inc. Personnel:

Name	Title	Contact information
Paul M Walker, MD, PhD	President and CEO	<a href="mailto:pwalker@spectraldx.com">pwalker@spectraldx.com</a> office: 416-626-3233 x 2100
Debra Foster	V.P. Clinical Development	<a href="mailto:dfoster@spectraldx.com">dfoster@spectraldx.com</a> office: 416-626-3233 x 2001 mobile: 647-205-5314
Andrew Kruspe	Technical Support	<a href="mailto:akruspe@spectraldx.com">akruspe@spectraldx.com</a> office: 416-626-3233 x 2002 mobile: 647-205-5326
Lisa Sauve	Controller/contracts	<a href="mailto:lsauve@spectraldx.com">lsauve@spectraldx.com</a> office: 416-626-3233 x 2007

## 9 List of Abbreviations and Definition of Terms

AE	Adverse Event
ACT	Activated Coagulation Time
ADE	Adverse Device Effect
AKIN	Acute Kidney Injury Network
ALT	Alanine Aminotransferase (Serum Glutamate-pyruvate Transaminase)
APACHE II	Acute Physiology and Chronic Health Evaluation Score (version II)
AST	Aspartate aminotransferase (Serum Glutamic Oxaloacetic Transaminase)
EAA	Endotoxin Activity Assay
C4	Cooper Clinical Coordinating Center
CPR	Cardio Pulmonary Resuscitation
CRF	Case Report Form
CRRT	Continuous Renal Replacement Therapy
CTCAE	Common Terminology Criteria for Adverse Events
CTC	Common Terminology Criteria for AEs
CVI	Cumulative Vasopressor Index
DIC	Disseminated intravascular Coagulation
DHP	Direct Hemoperfusion
ECG	Electrocardiogram
HIPAA	Health Insurance Portability and Accountability Act
HIV	Human Immunodeficiency Virus
ICF	Informed Consent Form
ICH	International Conference on Harmonization
ICU	Intensive Care Unit
IDE	Investigational Device Exemption
IRRT	Intermittent Renal Replacement Therapy
ITT	Intent to Treat
IRB	Institutional Review Board
LPS	Lipopolysaccharide (also known as endotoxin)



MAP	Mean Arterial Pressure
MI	Myocardial Infarction
MODS	Multiple Organ Dysfunction Score
MV	Mechanical Ventilation
RIFLE	Risk, Injury, Failure, Loss, and End-stage Kidney Classification
PMX	Polymyxin B cartridge (TORAYMYXIN PMX-20R column)
PMX-DHP	Polymyxin B Direct Hemoperfusion
PTT	Partial Thromboplastin Time
RRT	Renal Replacement Therapy
SADE	Serious Adverse Device Effect
SAE	Serious Adverse Event
SCr	Serum creatinine
VP	Vasopressors
U	Units
U/ml	Units per milliliter
UO	Urinary output
UPC	Units of packed cells
USADE	Unanticipated Serious Adverse Device Effect
WBC	White Blood Cell

## 10 Introduction

### 10.1 Background

Endotoxin (lipopolysaccharide) is a component of the outer wall of Gram negative bacteria. An increase in endotoxin in the bloodstream can result from an invasive infection with Gram negative bacterial species or when the gastrointestinal barrier is compromised, allowing translocation of Gram negative bacterial products including endotoxin into the bloodstream. The resulting endotoxemia triggers the release of numerous inflammatory mediators including IL-6 and TNF-alpha. Thus, endotoxin acts as a primary trigger in the initiation and propagation of sepsis and multiple organ failure (Hotchkiss and Karl 2003). It has been reported that 60-80% of patients with sepsis have elevated levels of endotoxin (Marshall, Foster et al. 2004). Mortality from sepsis is reported to range from 30-50% and more than 250,000 Americans die from sepsis each year (Angus, Linde-Zwirble et al. 2001; Levy, Fink et al. 2003).

Several clinical trials have targeted endotoxemia in patients with sepsis but have failed to show a significant mortality benefit (Opal and Cross 1999; Beutler and Rietschel 2003). This may have been due to the failure of clinical criteria alone to be able to accurately identify patients with sepsis who also had a high level of endotoxin. In 2003, the FDA cleared the Endotoxin Activity Assay (EAA) as a means of diagnosing the level of endotoxin in patients. Prior to this there was no FDA-approved method of measuring endotoxin for clinical use. This assay can now be used to identify those patients with high levels of endotoxin in patients with sepsis. This assay for endotoxin is currently used for this purpose in the United States, Canada, throughout Europe, and in Japan.

Polymyxin B, an antibiotic, is known to be highly effective in binding endotoxin (Shoji 2003; Fiore, Soncini et al. 2006; Vesentini, Soncini et al. 2006). Endotoxin binds to Polymyxin B through ionic and hydrophobic bonds with a very high affinity constant. However, if Polymyxin B is given intravenously to humans it may have serious nephrotoxic and neurotoxic effects. Toray Industries has developed a method of covalently bonding Polymyxin B to polystyrene hollow fibers. The product, to be studied in the proposed clinical trial, is referred to as the PMX cartridge and refers to the combination of Polymyxin B bound to polystyrene fibers and packed within a cartridge. In the PMX cartridge these strong covalent bonds prevent Polymyxin B from leaking into the blood that passes through tightly packed fibers within the cartridge. A design feature of the cartridge allows for blood to pass through in a radial manner, thereby maximizing the surface area for endotoxin within the patient's blood to bind with a molecule of Polymyxin B.

An accumulation of medical evidence in animals and humans has demonstrated a high degree of safety of the PMX cartridge as well as its efficacy in removing endotoxin and improving hemodynamic function. In April 2007, Cruz et al (Cruz, Perazella et al. 2007) published a systematic review of the literature on the effects of PMX on patients with sepsis. PMX therapy was associated with a significantly lower mortality risk, and increase in mean arterial pressure, decrease vasopressor use and improved oxygenation as measured by  $PO_2/FiO_2$  ratio.

A randomized controlled trial supported the findings of the systematic review. The Early Use of Polymyxin B Hemoperfusion in Abdominal Surgery trial (EUPHAS) showed that the 28 day mortality for patients with septic shock patients randomized to treatment with the PMX cartridge was 32% compared to 53% mortality in the group that received best supportive medical care, including treatment with available anti-sepsis drugs (Cruz, Antonelli et al. 2009).

More than 70,000 patients have been treated with the PMX cartridge in Japan, Italy, France, Spain, Belgium, The Netherlands and the UK over the last 15 years. The ability to remove endotoxin from patients with sepsis who have high levels of endotoxin has the potential to have a substantial impact on reducing mortality in this severely ill patient population in the United States, as observed in at least two recent clinical trials from Italy and numerous clinical investigations in Japan.

## 10.2 Disease Background/Diagnosis

Sepsis is a complex syndrome that is difficult to define, diagnose and treat. It is a range of clinical conditions caused by the body's systemic response to an infection, which if it develops into severe sepsis is accompanied by single or multiple organ dysfunction or failure leading to death. Sepsis and septic shock remain important causes of morbidity and mortality even with the availability of effective antibiotics and therapeutic advances proposed by the Surviving Sepsis Campaign (Dellinger, Carlet et al. 2004; Dellinger and Vincent 2005; Dellinger, Levy et al. 2008).

Only recently have intensive care professionals begun to understand the mechanism of sepsis. Diagnosis can be difficult as some of the symptoms of sepsis, such as fever, rapid pulse and respiratory difficulty, are very general and can be found in many other disorders. In a recent survey conducted among physicians, 87% felt that the symptoms of sepsis can easily be attributed to other conditions, creating problems of late or misdiagnosis (Dellinger, Carlet et al. 2004).

### 10.2.1 Mortality

Sepsis is a major cause of mortality throughout the world, killing approximately 1,400 people worldwide every day (Angus, Linde-Zwirble et al. 2001). The real figure may, however, be as high as an additional 50% as deaths are often attributed to complications from cancer or pneumonia, and not from sepsis. Death is common among sepsis patients, with 30–50% of patients dying within the first month of diagnosis (Girard, Opal et al. 2005; Dellinger, Levy et al. 2008).

### 10.2.2 Septic Shock

Septic shock occurs when sepsis is complicated by low blood pressure that does not respond to standard treatment (fluid administration) and leads to problems in one or more of the vital organs. The condition means that the body does not receive enough oxygen to properly function and drugs called vasopressors are used to raise the blood pressure. Septic shock patients are very ill and need rapid emergency admission to the hospital intensive care unit (ICU). Despite active treatment in the ICU, the death rate is around 35%.

### 10.3 Preclinical and Toxicology Studies

In order to meet the requirements regarding biological properties, numerous tests have been carried out according to regulatory standards. The following list gives an overview:

**TABLE 1. SUMMARY OF PRECLINICAL AND TOXICOLOGY TEST**

Name of Test <sup>A</sup>	Test Category	Results overview
Cytotoxicity	In Vitro Tests PMX Fibers with Murine Fibroblasts	Negative
Sensitization	Animal Tests PMX Fibers With Guinea Pigs	Negative reaction at 24 and 48 hours
Irritation/Intracutaneous reactivity	Animal Tests PMX fibers and PMX-B Column Extracts with Rabbits	Passed: No Irritation
Acute systemic toxicity	Animal Tests PMX-B Column Extracts With Mice	Passed:
Pyrogenicity	Animal Tests PMX-B Column Extracts With Rabbits	Passed: 3/9 rabbits had mild reaction
Implantation	Animal Tests PMX-B Column Fibers With Rabbits	Passed:
Hemolysis	Tests PMX-B Column Extracts With Rabbit Whole Blood	Passed: 3.5% reaction rate
Mutagenesis	Ames Test	Passed
Polymyxin B Concentration	In Vitro Elution Test	Passed: 0.1 to 0.96 U/ml elution <sup>B</sup>
Polymyxin B Concentration	Animal Test Plasma conc. PMX in dogs after hemoperfusion	Passed: < 2.5 U/ml (LLD)
Bactericidal activity	Batch And Circulation Test	Passed

- A. Extracted from Assessments and performance of the Toraymyxin Blood Purification Device. By Medical Technology Consultants, Ltd 1999
- B. Polymyxin B has no toxicity effect at approximately 20 U/ml

The PMX columns have passed all preclinical and clinical testing required to obtain a CE rating for safety.

### 10.4 Human Clinical Studies

The medical device used in this study is the TORAYMYXIN PMX-20R (PMX cartridge), which is an extracorporeal hemoperfusion cartridge intended for the selective removal of endotoxin from circulating blood through direct hemoperfusion (DHP). The PMX cartridge was approved for use in Japan in 1993, in the EU in 1998 and in Canada in 2003. To date, there have been more than 70,000 patients treated with the PMX cartridge. The first human trials using the PMX cartridge were performed in Japan in 1989.

Two recently reported trials provide strong evidence of the efficacy of the PMX cartridge. The first is the EUPHAS trial (The Early Use of Polymyxin Hemoperfusion in Abdominal Sepsis). This was a randomized prospective multicenter trial which has shown a statistically

significant reduction in 28-day mortality in patients treated with the PMX cartridge in addition to standard care (PMX patients) compared to patients who were treated with standard care alone (control group) in 10 hospitals in Italy. All patients had a diagnosis of severe sepsis with hypotension or septic shock following intra-abdominal surgery. Patients randomized to receive PMX hemoperfusion underwent extracorporeal circulation with the PMX cartridge for 2-3 hours twice over a 24 hour period. The 28 day mortality rate was 11/34 (32%) for the PMX group and 16/30 in the conventional group (53%). Following adjustment for SOFA score the PMX group had a significant reduction in 28 day mortality (adjusted HR 0.36, 95% CI 0.16-0.80,  $p=0.012$ ). The mortality benefit continued beyond 28 days through to hospital discharge (Dinna N. Cruz 2009).

A second prospective trial was carried out in Italy, which was conducted at the Niguarda Hospital in Milan. This trial showed a 60% relative reduction in in-hospital mortality in patients with refractory septic shock and confirmed endotoxemia who were treated with the PMX cartridge in addition to standard medical care ( $n=7$ ) compared to patients with severe sepsis with hypotension or septic shock and endotoxemia who received standard medical care alone ( $n=14$ ).

The EAA assay was used in this trial to measure the level of endotoxin in patients with severe sepsis and hypotension or septic shock (total 43 patients). Only patients with high levels of endotoxin ( $\geq 0.60$  EAA units) were enrolled into the trial ( $n=21$ ).

Of the 21 patients with high EAA who were enrolled, only patients with refractory shock were treated with the PMX cartridge. Refractory shock was defined as patients who had received full treatment according to the Surviving Sepsis Guidelines (Dellinger, Levy et al. 2008), were receiving norepinephrine  $>0.3$   $\mu\text{g}/\text{kg}/\text{min}$ , and had 3 or more organs failing. The 14 remaining patients with septic shock or severe sepsis with hypotension and high EAA were the comparison group. While both groups fulfilled the criteria of septic shock, the PMX group represented patients with a greater severity of illness, and therefore a higher likelihood of mortality.

Of the 21 patients that had severe sepsis with hypotension or septic shock and high EAA levels ( $\geq 0.60$ ), fourteen (14) subjects received standard medical care and 7 received standard medical care plus the PMX cartridge for 2-3 hours, twice over a 24 hour period. Despite greater severity of illness in the PMX cartridge treated group the mortality was compared to in the non-PMX treatment group.

The data of this trial using PMX has not been published but was presented at the Società Italiana di Anestesia, Analgesia, Rianimazione e Terapia Intensiva (SIAARTI) Conference, Palermo, Italy, in October 2008 and supports the potential utility of measuring endotoxin in patients who will receive anti-endotoxin therapies.

Cruz et al published a systematic review of the literature on the effects of the PMX cartridge in patients with sepsis (Cruz, Perazella et al. 2007). The meta-analysis included 28 publications between 1998 and 2006 with a pooled sample size of 1425 patients, 978 of

whom received the PMX cartridge and 447 received standard medical care alone. The major finding was that PMX therapy was associated with significantly lower mortality risk (Relative Risk 0.53, 95% CI, 0.43–0.65,  $p < 0.001$ ) based on the pooled data for hospital mortality (61.5% in the standard medical care group and 33.5% in the PMX cartridge group). This dramatic reduction in mortality was accompanied by an increase in mean arterial pressure of 19 mmHg (95% CI, 15-22 mmHg,  $p < 0.001$ ) representing a 26% mean increase in MAP (range 14-42%). Concomitantly, there was a decrease in vasopressor dose by 1.8  $\mu\text{g}/\text{kg}/\text{min}$  (95% CI, 0.4-3.3,  $p = 0.01$  after PMX use. The mean  $\text{PO}_2/\text{FiO}_2$  ratio increased by 32 units (95% CI 23-41,  $p < 0.001$ ). For patients who received PMX, endotoxin levels decreased by 21.2 pg/ml (95% CI, 17.5-24.9 pg/ml  $p < 0.001$ ) compared to endotoxin levels in patients receiving standard medical care. This represents a decrease in endotoxin of between 33% and 80% from pre-PMX treatment levels. The conclusion reached was that based on this critical review of the published literature, PMX appears to have favorable effects on critical physiological outcomes and mortality. No endotoxin measurements by EAA were included in any of these studies, either as inclusion or monitoring criteria, as the assay was not available in those countries at the time these studies were conducted.

#### 10.4.1 Contraindications

Treatment with PMX is contraindicated in the following subjects:

- Subjects in whom the use of heparin would put them at risk for uncontrolled or life-threatening bleeding, such as recent gastrointestinal hemorrhage, risk for visceral or intracranial bleeding or for whom adequate anticoagulant therapy cannot be safely achieved, such as subjects with hemophilia;
- Subjects with known hypersensitivity to heparin or Polymyxin B.

Appendix 4 includes the Package Insert and Instructions for use of Toraymyxin PMX-20R

#### 10.4.2 Precautions Relating To Heparin Administration During PMX Treatment

The recommended heparin doses for PMX are as follows:

Priming (circuit)	4 Units (U)/ml *
Bolus	3,000 U
Maintenance (per hemoperfusion line)	20 U/kg body weight/hr**

\* The maximum maintenance dose allowed for any subject is 2,000 U/hr.

\*\*The heparin doses described above and the Activated Coagulation Time (ACT) value described below are intended as general recommendations.

The heparin dose can be adjusted during PMX treatment on the basis of clinical observation; ACT and/or partial thromboplastin time (PTT) (i.e. prothrombin) values.

(Some subjects, in particular subjects who have undergone surgery, may not be able to tolerate the above recommended levels of heparin. This may be due to: (1) presence of a continuous heparin infusion or regular administration of heparin prior to treatment with PMX and/or, (2) high ACT or PTT value prior to treatment with PMX.)

Closely monitor subject clotting time at intervals during the procedure to ensure that an adequate level of anticoagulant is maintained. Adjust the continuous infusion of heparin based on the ACT or PTT measurement. Maintain ACT or PTT within the range of 150 –180 sec or 50 – 60 sec respectively with a maximum of 240 sec or 100 sec, respectively. Blood for ACT or PTT measurement must be taken from the first sampling port on the inlet line (before the heparin line joins the inlet line).

#### 10.4.3 **Potential Adverse Events Identified in Clinical Studies**

Subjects with septic shock usually have severe underlying diseases, including, but not limited to cancer, trauma, and cardiovascular disease. These underlying diseases, deterioration in the subject's state of health and/or death due to the progression of sepsis may be reported as adverse events (AEs) during or after PMX treatment. The following AEs have occurred in subjects being treated with the PMX cartridge and are listed in the Package Insert (Instructions for Use) provided with the TORAYMYXIN PMX-20R (PMX Cartridge):

- Thrombocytopenia, Decreased blood pressure, Allergy (Erythema, etc.), Shock (Decreased blood pressure), Dyspnea, Tachycardia, Hypothermia, Chest pain, Vomiting, Cyanosis, Anaphylactic shock, Ventricular tachycardia, Ventricular fibrillation, Hypoxemia.

These events are also listed as possibly related to use of the PMX cartridge:

- Air embolism, Infection of entry site of hemoperfusion catheter, Puncture site bleeding, Abnormal bleeding (due to heparin),

In addition, there are events that pertain to the disruption of blood flow through the hemoperfusion cartridge are described in the Package Insert that may be related to the dosage and administration of anticoagulants, or to the pathological condition of the subject:

- Increased inlet pressure (pressure at the entrance of the cartridge)
- Blood clotting within the hemoperfusion system

#### 10.4.4 **Potential Adverse Reactions with Polymyxin B**

Polymyxin B is not released in clinically significant amounts from the normal use of the PMX cartridges. Information in regards to systemic or topical exposure to Polymyxin B is provided in the Package Insert for the TORAYMYXIN PMX-20R (PMX Cartridge).

**10.4.4.1 Drug to Drug Interactions with Polymyxin B:**

When Polymyxin B is administered intravenously concomitantly with anesthetics, muscle relaxants or aminoglycoside antibiotics, respiratory depression due to a curare-like stabilization effect (neuromuscular blocking action) may occur as a result of drug to drug interactions.

**10.4.4.2 Adverse Drug Reactions with intravenous Polymyxin B:**

Serious adverse drug reactions: Shock, Deafness, and Respiratory Depression due to neuromuscular blocking action.

Other adverse drug reactions: Renal disorder, Parasthesia, Dizziness, Headache, Pyrexia, Lethargy, Ataxia, Visual disturbance, Rash, Pruritus, Nausea, Vomiting, Anorexia, Diarrhea, Formication, Numbness of tongue, and Numbness of lips.

**10.4.4.3 Precautions related to dialysis catheter line insertion and presence during PMX treatment**

Risks associated with dialysis include air in the bloodstream, infection of entry site of dialysis catheter, puncture site bleeding, and clot formation in the vein around the catheter with chance of dislodgment of the clot to the lung.

**11 Study Objectives****11.1 Primary Objective**

The primary objective is to assess the safety and efficacy based on mortality at 28-days in the two (2) groups of subjects with septic shock who have high levels of endotoxin and are treated with standard medical care plus use of the PMX cartridge (twice within 24 hours), versus subjects who receive standard medical care alone.

**11.2 Secondary Trial Objectives:**

The following secondary objectives of the trial are as follows:

1. To compare mortality between the two groups at 90 days, 6 months and 12 months post start of treatment
2. To compare the change in endotoxin levels between the PMX cartridge treated group and the control group at 12 hours after completion of a second PMX cartridge, with a treatment target of a  $\geq 15\%$  reduction of EAA levels with PMX cartridge treatment
3. To compare the changes in vasopressor doses using the cumulative vasopressor index (CVI) for the two groups from Day 0 to Day 3
4. To compare the number of days of need for vasopressors in each group from Day 0 to Day 28 (days alive and off vasopressors)



5. To compare changes in mean arterial blood pressure (MAP) for the two groups from Day 0 to Day 3
6. Comparison of the changes in renal function from day 0 to Day 3:
  - i. Urine output
  - ii. Serum creatinine
7. To compare the effects of two uses of the PMX cartridge on progression of, and recovery from, organ dysfunction using the Multiple Organ Dysfunction Score (MODS) from Day 0 to Day 3
8. To compare the number of days of need for renal replacement therapy (RRT) in each group from Day 0 to Day 28 (days alive and off RRT)
9. To compare the number of days of need for mechanical ventilation (MV) in each group from Day 0 to Day 28 (days alive and off MV)
10. To compare the mean number of days spent in the hospital by subjects in each group for survivors to Day 28
11. To compare the survival time from baseline to death within 28 days
12. To compare the survival time from baseline to death within 90 days.

## **12 Investigational Plan**

### **12.1 Overview of Study Procedures**

This is a double-blind, randomized, controlled trial of standard medical care plus the PMX cartridge versus standard medical care alone in subjects with endotoxemia and septic shock.

Subjects in ICUs will be assessed for septic shock using suspicion of infection and hypotension requiring vasopressor support as primary criteria. Subjects (or surrogate decision maker) will then be consented to determine the presence of an elevated endotoxin level ( $\geq 0.60$  EAA units) using the Endotoxin Activity Assay (EAA).

If the EAA is elevated ( $\geq 0.60$  EAA units) and the full inclusion/exclusion criteria are met, as confirmed by the Clinical Coordinating Center, the consented subjects will be enrolled in the trial and randomized to receive either standard medical care for septic shock, or standard medical care plus the PMX cartridge (administered twice approximately 24 hours apart). The status of all subjects will be followed by clinicians using standard procedures as well as measures of the endotoxin levels by the EAA. Subjects will be followed daily to Day 3 (approximately 72 hours after randomization) then at Day 7 and at weekly intervals through Day 28 (-6, +1 days) while in the hospital. If subjects are discharged prior to Day 28, End of Study/Early Termination assessments (Day 28) will take place. For all subjects, a follow-up visit or telephone call will take place approximately 90 days ( $\pm 1$  day), 6 months and 12 months ( $\pm 7$  days) post start of treatment.

The study subjects, ICU physician investigators, and all ICU health care professionals except for the bedside ICU nurse, will remain blinded to allocation of treatment. Nephrologists and the ICU bedside nurses will know the allocation and be trained to record unblinded data. Nephrology staff will be trained to use the PMX cartridge on those subjects randomized to the PMX cartridge group and to maintain the blind for the subjects that are randomized to standard of care by following the procedure for a Sham perfusion. Study staff (PI and other ICU personnel involved in the subjects care) and the subject (and/or the subjects surrogate) will remain blinded to the treatment arm. Pre-study EAA results will be made available to the treating physician, but all subsequent EAA results from Day 0 through Day 28 are to be blinded.

Analysis of the primary efficacy outcome will occur at the completion of the 28 day assessment. The data will be unblinded at that time however, subjects will remain in the study for completion of the 90 day, 6 month and 12 month follow up.

## 12.2 Number of Subjects

Approximately 478 subjects (239 per arm) will be randomized. The subjects who were randomized after 9 April 2014 approximately 208 (104 per arm) will be used for analysis of the primary study objective. All the subjects will be included in secondary and safety analyses.

## 12.3 Study Centers

Approximately 60 study centers in the United States and Canada will be used.

The study sites will be initiated in a phase approach with 1-2 sites being selected to initiate and evaluate protocol procedures and assessments. The subsequent sites will be added in one or two phases after approximately 3-4 months.

A Clinical Coordinating Center will be listed as an adjunctive investigational site.

### 12.3.1 Cooper Clinical Coordinating Center (C4)

The study will utilize the Cooper Clinical Coordinating Center (C4). This center will act as a resource center for the study sites. They will be utilized for reviewing the individual criteria for eligibility for each subject before randomization. They will also provide guidance, advice, and recommendations on device related interventions. In addition, the C4 will provide guidance and advice on the use of the PMX cartridge and associated standard dialysis equipment. Health care professionals at the C4 will be listed as investigators and sub-investigators for this study and appropriate regulatory documents will be provided. Communication and advice between the sites will be documented according to GCP guidelines.

## 12.4 Study Population and Selection Criteria

### 12.4.1 Study Population

Subjects in the ICU who have septic shock and elevated endotoxin levels (EAA values  $\geq 0.60$  EAA units).

#### 12.4.2 Inclusion Criteria

The subject, or an acceptable surrogate health related decision maker, will be asked to sign an informed consent form. The subject (or surrogate) must understand, sign, and date the written voluntary informed consent form at the screening visit prior to any protocol-specific procedures being performed.

Subjects who meet the following criteria (and have a signed informed consent) will be allowed into the study:

1. Age  $\geq 18$  years of age
2. Hypotension requiring vasopressor support: Requirement for at least one of the vasopressors listed below, at the dose shown below, for *at least 2* continuous hours and no more than 30 hours \*
  - a. Norepinephrine  $> 0.05$  mcg/kg/min
  - b. Dopamine  $> 10$  mcg/kg/min
  - c. Phenylephrine  $> 0.4$  mcg/kg/min
  - d. Epinephrine  $> 0.05$  mcg/kg/min
  - e. Vasopressin  $> 0.03$  units/min
  - f. Vasopressin (any dose) in combination with another vasopressor listed above
3. The subject must have received intravenous fluid resuscitation of a minimum of 30mL/kg administered within 24 hours of eligibility
4. Documented or suspected infection defined as definitive or empiric intravenous antibiotic administration
5. Endotoxin Activity Assay  $\geq 0.60$  EAA units
6. Evidence of at least 1 of the following criteria for new onset organ dysfunction that is considered to be due to the acute illness
  - a. Requirement for positive pressure ventilation via an endotracheal tube or tracheostomy tube
  - b. Thrombocytopenia defined as acute onset of platelet count  $< 150,000$   $\mu$ /L or a reduction of 50% from prior known levels
  - c. Acute oliguria defined as urine output  $< 0.5$  mL/kg/hr for at least 6 hours despite adequate fluid resuscitation

---

\* When determining the eligible dose of vasopressors for a subject whose measured body weight is  $>100$  kg, the maximum weight of 100 kg (220 lbs) will be used. This maximum weight applies to both males and females.

### 12.4.3 Exclusion Criteria

Subjects who meet the following criteria will NOT be allowed into the study:

1. Inability to obtain an informed consent from the subject, family member or an authorized surrogate
2. Lack of commitment for full medical support
3. Inability to achieve or maintain a minimum mean arterial pressure (MAP) of  $\geq 65$ mmHg despite vasopressor therapy and fluid resuscitation
4. Subject has end stage renal disease and requires chronic dialysis
5. Subject is receiving clinical support for non-septic shock which includes the following examples
  - a. Acute pulmonary embolus
  - b. Transfusion reaction
  - c. Severe congestive heart failure (e.g. NYHA Class IV, ejection fraction  $< 35\%$ \*)
6. Subject has had chest compressions as part of CPR this hospitalization without immediate return to communicative state
7. Subject has had an acute myocardial infarction (MI) in the past 4 weeks
8. Subject has uncontrolled hemorrhage (acute blood loss requiring  $> 3$  UPC in the past 24 hours)
9. Major trauma within 36 hours of screening
10. Subject has severe granulocytopenia (leukocyte count less than  $500$  cells/mm<sup>3</sup>) or severe thrombocytopenia (platelet count less than  $30,000$  cells/mm<sup>3</sup>)
11. HIV infection in association with a last known or suspected CD4 count of  $< 50$ /mm<sup>3</sup>
12. Subject's baseline state is non-communicative
13. Subject has sustained extensive third-degree burns within the past 7 days
14. Body weight  $< 35$  kg (77 pounds)
15. Known hypersensitivity to Polymyxin B
16. Subject has known sensitivity or allergy to heparin or has a history of heparin associated thrombocytopenia (H.I.T.)
17. Subject is currently enrolled in an investigational drug or device trial

---

\* Please note that an ejection fraction of  $< 35\%$  does not automatically exclude the subject. This ejection fraction example is only intended to describe chronic severe congestive heart failure NYHA Class IV.

18. Subject has been previously enrolled in this trial
19. Any other condition, that in the opinion of the investigator, would preclude the subject from being a suitable candidate for enrollment, such as end stage chronic illness with no reasonable expectation of survival to hospital discharge
20. Subject has a screening MOD score  $\leq 9$

## 12.5 Study Treatments

### 12.5.1 Standard of Care Treatment

Subjects enrolled in this study have sepsis and therefore are likely to have infections. Antibiotic therapy should be administered as appropriate before enrollment and continued for an appropriate period during the study.

In addition to appropriate antibiotic therapy, it is expected that all subjects will receive evidence-based appropriate treatment of their severe sepsis according to International guidelines (Dellinger, Carlet et al. 2004; Dellinger, Levy et al. 2008). (See section 14.3.4 for an explanation of standardizing best practices for patients with septic shock).

Site selection and qualification will include sites that are currently utilizing and agree to continue to follow the basic tenets of the treatments outlined in the 2008 Surviving Sepsis Campaign.

### 12.5.2 Prohibited Medications

Experimental anti-endotoxin therapies.

## 12.6 Treatment Randomization

Subjects will be randomized to one of the following two treatment regimens:

- Standard medical care for septic shock plus the PMX cartridge
- Standard medical care for septic shock

### 12.6.1 Methods of Assigning Subjects to Treatment Groups

Initial subject eligibility will be determined by qualified study personnel at the clinical study site. Confirmation of subject eligibility will be determined by the Cooper Clinical Coordinating Center (C4) following a telephone interview with the enrolling site. If the subject is eligible, a system of subject randomization assigned by the CRO, based on a predetermined randomization schedule, will be accessed through an internet based system by the investigative site.

### 12.6.2 Randomization Schedule

For each study site, the pharmacy will dispense the 'treatment packages.' An independent statistician will generate the randomization schemes for the entire study. For each study site, subjects will be randomized in a 1:1 ratio to the two treatment groups (PMX cartridge plus standard of care or standard of care alone). A blocked randomization scheme with

mixed randomized block sizes of 2 and 4 will be used to provide approximately balanced allocation to the two treatment groups for each investigative site during the study.

### 12.6.3 Blinding

A “Randomization Certification” form will be generated via an internet based system. This form will be accessed via the WebView software module using a unique site ID. The form, once accessed by appropriate personnel, will have the randomization sequence for the site and will have the information to determine if the subject will receive a PMX cartridge or will not receive a PMX cartridge. This internet based form will be printed by the assigned study pharmacist who will record the Investigational Product (Device) kit serial numbers when the IP is dispensed. Since this form contains blinded information for the individual subjects, it will be retained securely at the pharmacy department.

The study subjects, ICU physician investigators, and all ICU health care professionals except for the bedside ICU nurse, and those who are involved in data analysis (except an independent statistician), will remain blinded to allocation of treatment.

Nephrologists involved in the hemoperfusion, the ICU bedside nurse and assigned pharmacist will know the treatment allocation and will be trained to record the following data onto CRFs that are kept blinded from remaining study personnel. They will record the treatment allocation by recording only the serial number of the carton, timing of device/sham use, adverse events (noted during the course of treatment) and concomitant anticoagulation administered (e.g. heparin). The nephrology staff will be trained to use the PMX cartridge on those subjects randomized to the PMX cartridge group and will be trained to perform a sham perfusion event to maintain the blind for the subjects that are randomized to standard of care.

All subjects will receive the treatment behind a closed curtain in order to remain shielded from the ICU staff that will be blinded to the treatment arm. Study staff (PI and other ICU personnel involved in the subjects care) and the subject (and/or the subjects surrogate) will remain blinded to the treatment arm.

The treatment allocation will be revealed following access to the WebView form by the Pharmacist or designated pharmacy personnel. An “investigational product carton”, which will contain either a PMX cartridge or sham materials, will be delivered from the pharmacy to the unblinded nephrologist who is assigned to perform the study perfusion.

Most of the processes involved in the PMX and sham perfusion treatments will be initiated by the unblinded nephrologist. For the subjects randomized to the sham perfusion group, no catheter will be inserted and no dialysis will occur. However there will be a sham dialysis catheter connected to the appropriate perfusion tubing which will be concealed from the ICU treating staff. The dialysis catheter will be placed over the skin with occlusive dressing with the access ports remaining visible. During the 2 hour period of hemoperfusion, a blood pump and associated tubing will be wheeled to the subject’s bedside. The machine

will be running in a **recirculation** mode wherein the return line is connected to the withdrawal line and the subject is out of the circuit.

After the 24 hour intervention period wherein two, 2 hour sessions of sham perfusion is scheduled to occur, the sham access site will be made similar to the access site of the PMX treatment group by removing the line from the skin surface and covering the area with the same dressing for the usual period of time.

For the subjects randomized to the PMX cartridge group, the same precautions of blinding will remain and the dialysis catheter and perfusion tubing used will be concealed from the blinded ICU-treating staff. A member of the nephrology team or critical care team will be responsible for the insertion of a femoral or internal jugular venous access catheter that must be dedicated to hemoperfusion only, with the appropriate occlusive dressing with access ports remaining visible. After the 24 hour intervention period wherein two, 2 hour hemoperfusion interventions are scheduled to occur, the central venous access site will be made similar again by removing the line and covering the area with the same dressing as the sham group for the usual period of time.

A set of unblinded CRFs for recording perfusion start and stop times and dose of anticoagulant (e.g., heparin) given, if necessary, as well as any device related events, will be stored and monitored separately. The unblinded CRFs will be filled out by the nephrology staff and will be signed by the site's unblinded sub-investigator.

It is imperative that ICU subjects are overseen by an ICU nurse at all times and it is unsafe to do otherwise. Therefore, the ICU bedside nurse will be unblinded to the treatment allocation of the subject in order to address medical conditions that might arise during or after the sham or PMX hemoperfusion.

An unblinded sub-investigator, typically part of the nephrology team, will be assigned to record on the CRF adverse events that occur during the following time points: while the subject is being prepared for use of the investigational device, when the device is being administered and throughout the treatment phase (Days 1 through 3). The sub-investigator will be responsible for reporting the applicable events to the Sponsor (or the designee, Amarex) during this time to maintain the blind. However, if the blind has been broken, it will be recorded on the CRFs. If the event occurs during the 1<sup>st</sup> hemoperfusion event, and it is deemed safe for the subject to continue in the study, every effort will be made to maintain the procedures for the blind for the second hemoperfusion with the active or sham treatment.

### 13 Investigational Device (PMX Cartridge) Overview

#### 13.1 Investigational Device (PMX Cartridge) Names

##### 13.1.1 Generic name: PMX cartridge

##### 13.1.2 Trade name: TORAYMYXIN PMX-20R Extracorporeal Hemoperfusion Cartridge

#### 13.2 Investigational Device (PMX Cartridge) Physical and Chemical Characteristics

TORAYMYXIN PMX-20R (PMX) is an extracorporeal hemoperfusion cartridge intended for the selective removal of endotoxin from circulating blood through direct hemoperfusion (DHP).

The PMX cartridge (cartridge) contains fibers made of polystyrene derivatives (alpha-chloro-aceto-amidomethylated polystyrene). Polymyxin B is immobilized on the surface of these fibers (see Figure 1). This fixed Polymyxin B adsorbs and removes endotoxin from the patient's circulating blood.

**Figure 1. Diagram of PMX Cartridge**

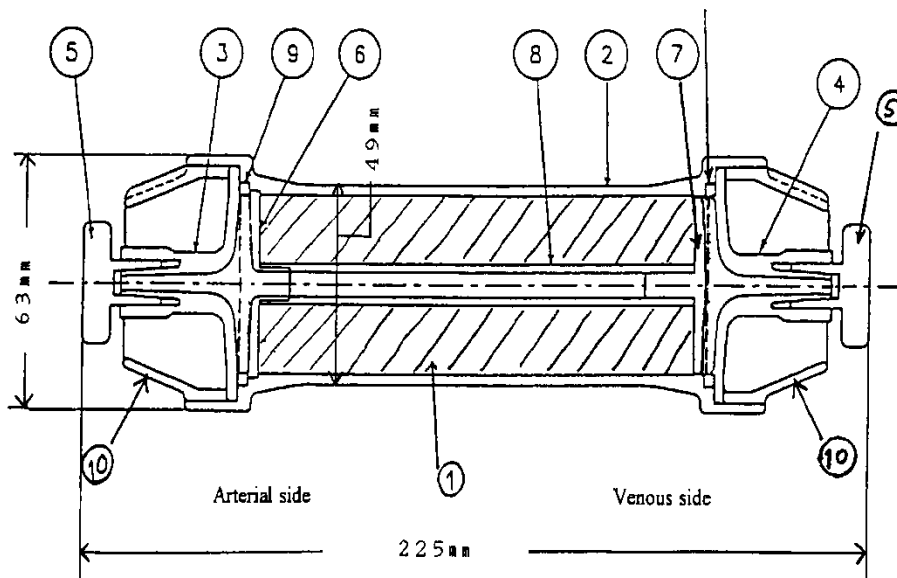

- |                                  |                       |            |
|----------------------------------|-----------------------|------------|
| 1 Polymyxin B immobilized fibers | 2 Case                | 3 Header A |
| 4 Header B                       | 5 Luer Lock Connector | 6 Plate A  |
| 7 Plate B                        | 8 Pipe                | 9 Filter A |
| 10 Header Cover                  |                       |            |

Each cartridge contains  $56 \pm 3$  g fibers (dry weight) and has a blood volume capacity of  $135 \pm 5$  ml. The dimensions and structure of the cartridge are as follows:

- Length: 225 mm
- Diameter (max): 63 mm



- Housing diameter: 49 mm
- Connection between the cartridge and blood tubing: Luer-lock type connectors

The following additional equipment is needed to carry out treatment with PMX:

- A blood pump for extracorporeal circulation capable of a blood flow rate of 20 – 200 mL/min, monitors for inlet (Pi) and outlet (Po) pressures and an infusion pump and port for the administration of anticoagulants,
- Hemoperfusion blood tubing suitable for use with the hemoperfusion pump,
- For extracorporeal circulation by venovenous access, insert a 12F or 14F double lumen catheter into the femoral vein.

### 13.3 Labeling and Packaging of PMX Cartridges

PMX cartridges are manufactured by Toray Industries, Tokyo, Japan. Spectral Diagnostics has the exclusive license to develop, market, and distribute PMX cartridges in the US and Canada.

PMX Cartridges will be distributed to the sites by a regulatory compliant pharmaceutical packaging and distribution service using the current GMP and FDA regulations for labeling and shipment of investigational devices.

PMX cartridges will be shipped in appropriate cartons in an overbox for protection and each study site pharmacy will have up to 8 cartons available.

The individual PMX cartridges have a CE label (Figure 2a). The PMX cartridges used in this study will also be labeled as “Investigational Device”. The overbox label is Figure 2b.

Figure 2a. PMX Cartridge Label



Figure 2b. Overbox Label

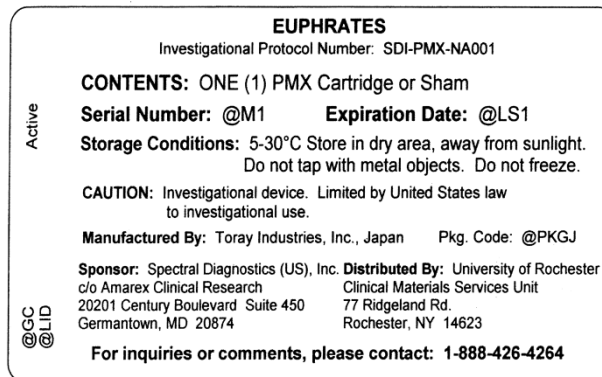

#### 13.4 Sham Carton

There will be no sham cartridge. However, a sham carton with similar size and weight and general appearance of the PMX cartridge carton will be sent to the study site pharmacy.

The sham carton will not contain any investigational device. Each study site pharmacy will have up to 8 sham cartons available.

#### 13.5 Required Documents Prior to 1st PMX Cartridge and Sham Carton Shipment:

Supplies needed for the PMX cartridge will not be sent to the Investigator's clinical site until Spectral has received the following documentation:

- Signed confidentiality agreement
- A copy of the signature page from the final protocol and amendments if applicable, signed and dated by both Spectral Diagnostics, Inc. and the Investigator
- Written approval of the protocol from the Institutional Review Board (IRB) of the institution where the study is to be conducted, its consent form, and any study-related documents distributed to subjects
- A copy of the IRB approved subject information and consent form to be used in the study and any study-related documents given to subjects
- A signed and dated Investigator Agreement Form with the Principal Investigator's (PI) signed and dated Curriculum Vitae
- FDA Financial Disclosure Form(s) for the Principal Investigator and Nephrologist
- Current CVs and Medical licenses for the Principal Investigator and Nephrologist
- A signed, fully executed Clinical Trial Agreement (CTA) and budget
- Regulatory approval for the country in which the study is being conducted

#### 13.6 Summary of Investigational Device Use (Perfusion)

The subject will have a central venous access line inserted into a femoral or internal jugular vein, and then the access line is attached to a blood pump capable of a flow rate of 80 to 120 mL/minute. The blood passes through a PMX cartridge then is returned to the subject. The subject undergoes this extracorporeal blood circulation for approximately 1½ to 2 hours per cartridge at a flow rate of approximately 100 ml/minute, but will be used within the range of 80 to 120 ml/minute. A double lumen hemodialysis catheter will be used for PMX cartridge administration. Subjects will receive 2 cartridges approximately 24 hours apart.

There will be no re-treatments with the PMX cartridge after the completion of the 2<sup>nd</sup> cartridge.

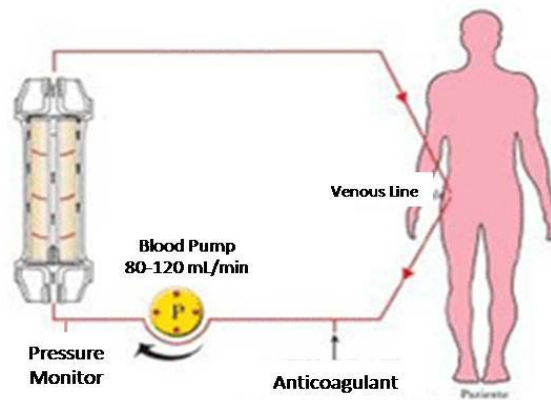
**Figure 3: Perfusion Schematic for the PMX Cartridge**

### 13.7 PMX Cartridge and Sham Carton Shipping, Storage, Preparation, and Handling Instructions

Detailed instructions for storage, preparation, handling and administration of the PMX cartridge and sham cartons are provided to the clinical sites within the Study Operations Manual. Kits containing the PMX cartridges and shams may be stored at room temperature at the clinical site's pharmacy.

Shipment of the devices will be conducted from a central device dispensing center that will maintain a shipment and dispersion log. On arrival at the clinical sites, the log and additional documentation of the storage and handling of the cartons will be recorded with appropriate information as indicated in the Study Operations Manual. Study cartons must be kept in a secure area at the investigator's site until it is utilized by a subject.

#### 13.7.1 Investigational Device, Accountability and Reconciliation

Records must be maintained that document the shipment, receipt, disposition, return and/or destruction of the investigational device. The investigator (or delegated representative, i.e. unblinded pharmacist) is responsible for accounting for all unused and used PMX cartridges. All IP cartridges dispensed from the pharmacy (whether used or unused) will be destroyed according to the investigative site's biohazardous waste disposal procedures. They cannot be returned to inventory. Refer to the Study Operations Manual and Pharmacy Manual for further instructions. The PMX cartridge and Sham cartons dispensing logs maintained at the clinical site must be available for monitoring, auditing or inspection.

At the completion or termination of the study, a final accountability review and reconciliation must be completed; any discrepancies must be investigated and their resolution documented. Unused PMX cartridges are to be returned to the assigned vendor, or destroyed on-site, as instructed in the Study Operations Manual.

As the transmission of HIV and other blood-borne pathogens can occur through contact with contaminated needles, blood, and blood products; appropriate blood and secretion precautions will be employed by all personnel in the use and handling of the investigational device or sham carton materials after use.

## **14 Study Outline and Visit Assessments**

### **14.1 Informed Consent Processes**

Informed consent will be attempted to be obtained from each eligible subject. However, it is recognized that critically ill subjects may not have adequate decision-making capacity. It is necessary for the investigator to carefully assess the subject's competence and decision-making capacity and, if necessary, empower a suitable surrogate to act on his or her behalf. Due to the entry criteria for this study, surrogate consent will be the usual consent process. There will be two (2) informed consent processes. The first is to obtain permission for a blood sample to be taken to assess endotoxin levels using the EAA in subjects who meet all other entry criteria. In addition, a minimal data set including age, gender and 28 day mortality status will be kept for this group of subjects.

The EAA is an FDA approved diagnostic test (K021885). However, it is not a routine standard of care for septic shock and in this case will be obtained for research purposes, thus the subject (or surrogate decision maker) will be asked to sign an informed consent form prior to obtaining the blood sample.

The second informed consent will be obtained at the end of screening, following the determination that the subject is still eligible for the treatment part of the protocol and has an EAA  $\geq 0.60$ . This process will take place after the result of the EAA test has been completed but before randomization and treatment may begin. This consent will detail the nature and purpose of the main study, the possibility of venous access and PMX cartridge treatment, and all risks/benefits.

Individual site consent processes for the 1<sup>st</sup> (EAA) and 2<sup>nd</sup> (Treatment) consents may be combined into a single informed consent form. Alternatively, both informed consents may be obtained at the same time.

Each subject (or surrogate decision maker) will sign the informed consent form(s) after having been informed of the nature, aims, and methods of the clinical trial. The original signed consent form(s) will remain in the investigator's file; a copy of the fully executed consent form will be given to the subject.

If the initial written informed consent form is obtained from a surrogate decision maker, the subject must also give consent as soon as she/he is able.

A copy of the informed consent will be placed on the chart and a copy given to the consentor. The informed consent process will be written on the chart by a member of the investigative team that documents enrolment and a brief one/two sentence description of the trial.

Health Insurance Portability and Accountability Act (HIPAA) authorization will also be obtained from participating subjects.

## 14.2 Subject Identification

Each subject will be assigned a unique identification number just prior to randomization. The screening number will be composed of a two-digit site number assigned by the Sponsor, followed by three letters of the person's initials, and a sequential three digit number starting with 001 (example "01-XYZ-003"). If the subject does not have a middle initial, a dash is to be used as a place holder (example "01-D-A-004"). All subjects with septic shock who are screened for the study are to be documented on a cumulative Screening Log, including the reason(s) for not qualifying. A Screening Log template is provided in the Study Operations Manual, along with instructions for completion. If the subject has an EAA <0.60, this does not qualify the subject for the randomized treatment protocol, but this information will be documented along with a minimal data set of age, gender and assessment of mortality at Day 28.

If EAA is  $\geq 0.60$ , an attempt will be made to enroll the subject in the randomized treatment protocol.

All subjects who consent into the study are to be documented on a cumulative Enrollment Log. An Enrollment Log template is provided in the Study Operations Manual, along with instructions for completion. The investigator must also maintain a list of subject names and identifying information on a confidential Subject Master Log.

## 14.3 Subject Screening Overview

### 14.3.1 Overview of Screening

The screening process begins at study defined vasopressor infusion of at least 2 continuous hours and ends at randomization. It includes the following assessments:

1. Patient is receiving antibiotics
2. Fluid resuscitation of  $\geq 30$  ml/kg
3. Requiring vasopressor per inclusion criteria
4. Presence of 1 new organ dysfunction per inclusion criteria
5. No exclusion criteria present
6. EAA Consent
7. Perform EAA

If EAA result is  $\geq 0.60$  EAA units:

- Consent for randomization (if not already done)
- Contact C4

If the EAA result is  $< 0.60$  units:

- Screen failure
- Document 28 day mortality status

#### 14.3.2 Screening Process

Subjects in Intensive Care Units (ICU) will be assessed for initiation of intravenous antibiotics and vasopressor therapy for hypotension.

When identified, the subject will be further screened for:

1. Hypotension requiring vasopressor support (requirement for at least one of the vasopressors listed below, at the dose shown below, for *at least* 2 continuous hours and no more than 30 hours). When determining the eligible dose of vasopressors for a subject whose measured body weight is >100 kg, the maximum weight of 100 kg (220 lbs) will be used. This maximum weight applies to both males and females.
  - a. Norepinephrine > 0.05mcg/kg/min
  - b. Dopamine > 10 mcg/kg/min
  - c. Phenylephrine > 0.4 mcg/kg/min
  - d. Epinephrine > 0.05 mcg/kg/min
  - e. Vasopressin > 0.03 units/min
  - f. Vasopressin (any dose) in combination with another vasopressor listed above
2. Documented or suspected infection
3. The subject must have received intravenous fluid resuscitation of a minimum of 30mL/kg administered within 24 hours of eligibility
4. Subject meets none of the exclusion criteria

Once the primary screening criteria above have been reviewed, the subject (or the surrogate decision maker) will be asked to sign an Informed Consent to permit the endotoxin levels to be determined using the EAA. This consent form will mention that if the EAA is high ( $\geq 0.60$  EAA) they will be approached for potential consent for a treatment study.

Since it is critical for the validity of the EAA test, the EAA sample testing must start within 3 hours of sample collection.

The subject must be on any dose of vasopressor at the time the EAA sample is collected. Subjects are not required to be on vasopressors at randomization or treatment.

If subjects have an EAA assay result that is below 0.60 EAA units, the assay may be repeated one time 4-6 hours later as long as the test results are completed within 24 hours from time of informed consent and the subject would still meet entry criteria. If the second EAA test is negative, the subject will be classified as a screen failure for the treatment phase of the study, however there will be an assessment for mortality status at day 28.

If the EAA test result is  $\geq 0.60$  EAA units, the subject, or an acceptable surrogate decision maker, will be asked to sign another Informed Consent form to permit randomization into the treatment phase of this study. Once the subject meets the eligibility criteria, including the endotoxin level and a signed informed consent have been obtained, the Clinical Coordinating Center (C4) is to be contacted for eligibility confirmation. The C4 will confirm to the site that randomization of eligible subjects can occur.

#### 14.3.3 Screen Failures (eligible subjects with EAA consent and/or known EAA value)

Screen failures will be documented in the following manner:

- All inclusion and none of exclusion criteria are met and the EAA is performed but the level is  $< 0.60$  EAA units
- Baseline assessments reveal that the subject has met an exclusion criteria prior to randomization
- All inclusion and none of exclusion criteria are met, EAA performed is  $\geq 0.60$  EAA units but informed consent for treatment phase of the study is not signed, or is withdrawn prior to randomization.

Screen failures are not eligible for randomization and therefore will not be included in the efficacy or safety analyses. However, their mortality status at 28 days will be documented.

#### 14.3.4 Standardizing essential treatments of sepsis

The Surviving Sepsis Campaign (SSC) International Guidelines for Management of Severe Sepsis and Septic Shock were published in 2004 (Dellinger, Carlet, et al. Intensive Care Med and Critical Care Med, 2004). The guidelines revision was published in 2008 and further revised in 2012 (Dellinger, Levy et al Crit. Care Med). These evidenced-based guidelines set forward “best practice” in the management of severe sepsis and septic shock. (Appendix 5)

In 2005 the SSC initiated a performance improvement (PI) program in collaboration with the Institute for Healthcare Improvement (IHI). This included the development of a management plan for severe sepsis and septic shock whereby key recommendations from the SSC guidelines were grouped into a “bundle” with treatment goals to be accomplished during a pre-defined period of time. The 6 hour bundle (sepsis resuscitation bundle) is applicable to the patient population for this study. Some of the SSC quality indicators within the 6 hour bundle are built into the study protocol and accompanying CRF’s, for example the fluid challenge (minimum of 30 ml/kg crystalloid or colloid), use of vasopressors and antibiotic therapy.

However, it must be made clear, that there may be circumstances where guidelines recommendations, cannot or should not be followed for an individual patient. For example



if there is limited intravenous access in a patient that allows infusion of antibiotics but not the drawing of blood cultures. This may be due to clinical characteristics of that patient which alter the conditions for use of the bundle component or a patient or patient's family preferences override its implementation.

As a show of commitment to the SSC guidelines, all site principal investigators will have signed the Investigator Signature page indicating that they, their co-investigators and the unit directors/ICU physicians where the subjects are enrolled support and where possible, follow the basic tenets of the Surviving Sepsis Campaign Guidelines on the Management of Severe Sepsis and Septic Shock.

#### 14.3.5 Baseline Assessments

After the subject has been randomized, the following assessments and procedures to determine baseline values will be recorded in the subject's record (source document and CRF). The time period for capturing the baseline assessments includes the period from primary and secondary screen to the time of initiation of PMX cartridge or sham treatment.

1. Inclusion/Exclusion criteria review
2. Demographics
3. Medical History
4. Physical exam, including height and weight
5. Blood samples (approximately 8 ml) for Laboratory assessments (hematology, coagulation and chemistry)
6. Serum or urine pregnancy test (for females of childbearing potential)
7. Two sets of blood cultures (aerobic and anaerobic for each set) must be drawn for baseline assessment and results recorded in the CRF for baseline (day 0) assessments. Results are not required prior to randomization. Any other microbiology cultures collected as part of Standard of Care from Day 1 to Day 28 will be recorded on the Microbiology Culture results page in the CRF, including those with a report of "no growth". \*
8. Vital signs (core temperature, heart rate, systolic and diastolic blood pressure, MAP, CVP, respiratory rate, FiO<sub>2</sub>, PO<sub>2</sub>, O<sub>2</sub> saturation)\*
9. 12-lead ECG
10. Renal function (urine output)\*
11. APACHE II score
12. Document use of Mechanical Ventilation (MV)
13. Document use of Renal Replacement Therapy (RRT)
14. Document Vasopressor use (medication type, dose range etc.) for CVI

15. Concomitant medications

16. Urinalysis

Standard medical care of the subject will continue during the study-related assessments. See schematic for timeline of assessments.

\*Note: Assessments for baseline recording can be performed during the primary and secondary screening period, i.e. -12h to initiation of treatment at the exception of the following:

- Blood cultures may be drawn up to 24 hr prior to randomization, or anytime during baseline
- Urine output may be collected over a maximum of 24 hr prior to the first treatment
- Vital signs may be measured within 4hr of randomization.

#### 14.4 Day 1 Processes and Assessments

Day 1 will be designated as the 24 hour period from the start of the first treatment to the end of the second treatment.

##### 14.4.1 Schematic Day 1 Processes and Assessments

Figure 4. Schematic Day 1

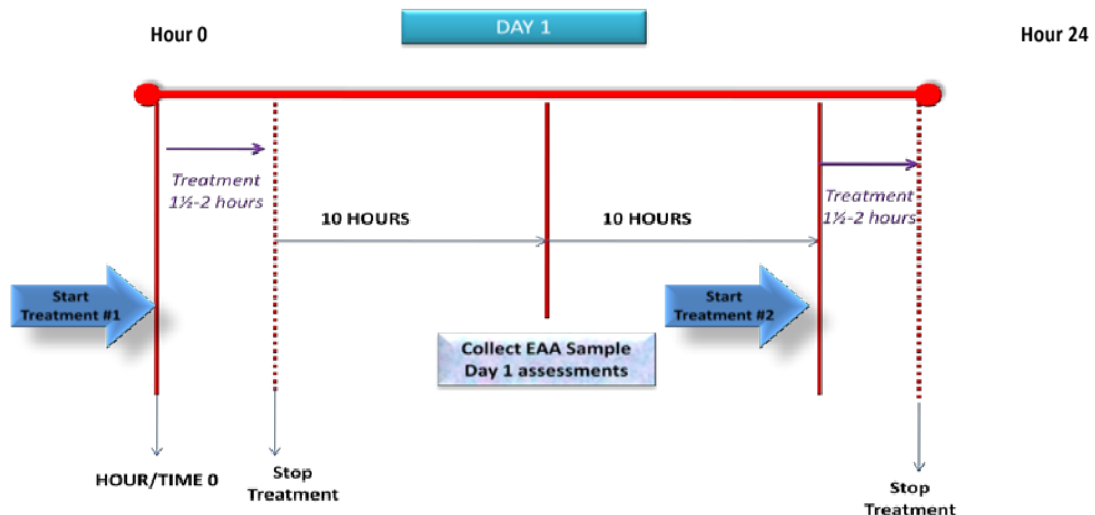

##### 14.4.2 First PMX Cartridge (or Sham) Treatment

After the study-related screening and baseline assessments have been completed and the subject is randomized, the subject will be prepared for the 1<sup>st</sup> treatment.

Neither the subjects (nor responsible representatives) are to be informed of the treatment assignment. The trained, unblinded nephrology staff will administer and supervise the subjects during the treatment phase of the study. Subjects will be randomized to receive one of the two treatment groups:

- Administration of 1<sup>st</sup> PMX Study cartridge (for 1½ to 2 hour interval) or,
- Sham perfusion : Non functional/non-invasive dialysis catheter and associated perfusion tubing set (Note: The sham will not be attached and no perfusion procedures will be performed)

The nephrology staff will record on unblinded CRFs the start time and stop time of the perfusion, concomitant device related anticoagulation medications, investigational device codes and serial number, any device malfunctions and any reported AEs for each subject.

First PMX Cartridge (or Sham) completed treatment is defined as a minimum of 1.5 hours with the subject's blood in contact with the filter or time elapsed while on sham. Treatment start is defined as when the cartridge is exposed to the subject's blood. Sham treatment starts upon hemoperfusion machine recirculation.

Note: Blood sample for EAA to be obtained 10 hours (+/- 30 minutes) after the completion of the PMX Cartridge /sham perfusion on Day 1.

#### 14.4.3 Day 1 Safety and Efficacy Assessments

##### **EAA test:**

At 10 hours ( $\pm$  30 minutes) after completion of the 1<sup>st</sup> treatment with the PMX column (or sham administration), a 3ml whole blood sample will be obtained for the EAA test.

##### **Assessments:**

At approximately 10 hours ( $\pm$  2 hours) after the completion of the 1<sup>st</sup> treatment safety and efficacy assessments are to be completed

1. Vital signs
2. Urine output
3. Data elements for MOD score
4. Document use of Mechanical Ventilation
5. Document use of Renal Replacement Therapy (RRT)
6. Document vasopressor use (medication type, dose range, etc ) for CVI
7. Blood samples (8 ml) for laboratory assessments (hematology, coagulation and chemistry)
8. Concomitant medications

#### 9. Adverse event and adverse device effect

Date and time of assessments will be noted on the source documents and CRF.

The trained, unblinded ICU bedside nurse will be responsible for changing bandages and maintaining site of dialysis (if present).

#### 14.4.4 Second PMX Cartridge (or Sham) Treatment

After the Day 1 study-related assessments are completed, the subject is to be prepared for the 2<sup>nd</sup> treatment of the PMX cartridge or sham treatment (within 20-22 hours after start of the 1<sup>st</sup> PMX cartridge treatment or sham treatment).

The trained, unblinded nephrology staff will supervise and administer the treatment groups. Neither the subjects (nor responsible representatives) are to be informed of the treatment assignment.

- Administration of 2<sup>nd</sup> PMX Study cartridge (for 1½ to 2 hour interval) or,
- Sham perfusion: Sham dialysis catheter and associated tubing (Note: The sham will not be attached and no invasive perfusion procedures will be performed)

The nephrology staff will record on unblinded CRFs the start time of perfusion, the stop time off perfusion, concomitant device related medications, investigational device codes and serial number, any device malfunctions and any AEs and ADEs, including serious and unanticipated AE (USADEs, SADEs, and SAEs) for each subject.

Second PMX Cartridge (or Sham) completed treatment is defined as a minimum of 1.5 hours with the subject's blood in contact with the filter or time elapsed while on sham. Treatment start is defined as when the cartridge is exposed to the subject's blood. Sham treatment starts upon hemoperfusion machine recirculation.

Note: Blood sample for EAA to be obtained 10hours (+/- 30 minutes) following the completion of the PMX cartridge administration/sham perfusion on Day 2.

#### 14.5 Day 2: Procedures and Assessments

Day 2 is designated as the 24 hour interval after the second PMX cartridge/sham perfusion has been completed. The Day 2 assessments will take place approximately 10 hours after the completion of the 2<sup>nd</sup> PMX cartridge/sham perfusion.

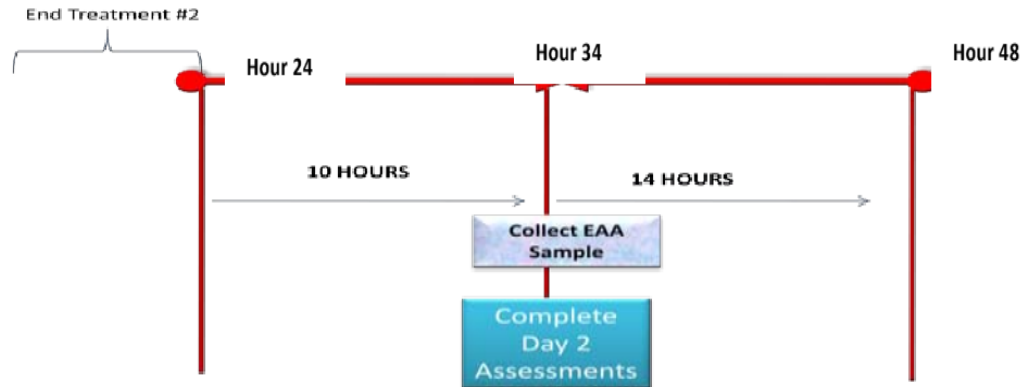
**Figure 5. Schematic of Day 2**

#### 14.5.1 Day 2 Safety and Efficacy Assessments:

##### EAA test

At 10 hours ( $\pm 30$  min.) after the completion of the **2nd treatment** with the PMX column (or sham administration) a 3 ml whole blood sample will be obtained for the EAA test.

##### Assessments

The following assessments are to be completed at 10 h ( $\pm 2$  hours) from the completion of the second PMX cartridge or sham perfusion,

1. Vital signs
2. Urine output
3. Data elements for MOD score
4. Document use of Mechanical Ventilation
5. Document use of Renal Replacement Therapy (RRT)
6. Document vasopressor use (medication type, dose range) for CVI
7. Blood samples (8 ml) for laboratory assessments (hematology, coagulation and chemistry)
8. Concomitant medications
9. Adverse events and adverse device effects review

Date and time of assessments will be noted on the source documents and CRF.

The trained, unblinded ICU bedside nurse will be responsible for changing bandages and maintaining site of dialysis (if present).

#### 14.6 Day 3 Procedures and Assessments

Day 3 will correspond to the 24 hour interval after Day 2

##### 14.6.1 Day 3 Safety and Efficacy Assessments

###### **EAA Test**

To be taken no earlier than 24 hours after completing the Day 2 assessments, but prior to the calculated end of Day 3.

###### **Assessments**

To be taken no earlier than 24 hours after completing the Day 2 assessments, but prior to the calculated end of Day 3

1. 3ml whole blood sample for the EAA test
2. Vital signs
3. Urine output
4. Data elements for MOD score
5. Document use of Mechanical Ventilation
6. Document use of Renal Replacement Therapy (RRT)
7. Document Vasopressor use (medication type, dose range etc) for CVI
8. Blood samples (8 ml) for laboratory assessments (hematology, coagulation and chemistry)
9. Concomitant medications
10. Adverse event review
11. Microbiologic culture report results

Date/ Time of assessments will be noted on the source documents and CRF.

#### 14.7 Day 7, Day 14 and Day 21 Assessments

Assessments on Day 7, 14 and 21 ( $\pm 1$  day) for each, include the following information to be collected from all days in the interim period:

1. Document daily need for Mechanical Ventilation(MV)
2. Document daily need for Renal Replacement Therapy

3. Document daily need for Vasopressors

The following safety and efficacy assessments will take place on the 7<sup>th</sup>, 14<sup>th</sup>, and 21<sup>st</sup> days after randomization:

1. Blood sample (3 ml) for EAA testing
2. Blood samples (8 ml) for laboratory assessments (hematology, coagulation and chemistry); NOTE: these lab tests are required only if they are the study site/s standard of care and collected within the protocol-specified window (i.e., these labs are not required if they are not the site's standard of care; additionally, these labs are not required if they are standard of care for the site, but collected outside the protocol-specified window).
3. Vital signs
4. Concomitant medication
5. Adverse event review
6. Microbiology culture reports (if available)

Date/ Time of assessments will be noted on the source documents and CRF.

#### 14.8 End of Study/Early Termination (Day 28) Assessments

The following assessments are to be performed if a subject terminates the study prematurely, or on the date of discharge (prior to day 28), or when the subject completes the study on Day 28 (-6/+1 day). Every attempt should be made to have subjects complete the Day 28 assessments for safety evaluation. In addition, if a patient has been discharged from the hospital prior to Day 28, a follow-up telephone visit will occur on (or after) Day 28 to ascertain survival status at 28 days following the first treatment.

1. Blood sample (3 ml) for EAA testing
2. Blood samples (8 ml) for laboratory assessments (hematology, coagulation and chemistry)
3. Physical Examination
4. Vital signs
5. 12 Lead ECG
6. Urinalysis
7. Mortality assessment
8. Concomitant medications
9. Adverse events review

Assessments on Day 28 include the following information to be collected and recorded from all days in the interim period (Days 22-27):

1. Document daily need for Mechanical Ventilation (MV)
2. Document daily need for Renal Replacement Therapy
3. Document daily need for Vasopressors

#### 14.9 Follow-Up Visit Assessments – 90 days ( $\pm 1$ day), 6 Months ( $\pm 7$ days) and 12 Months ( $\pm 7$ days)

Subjects or a secondary contact (next of kin or general care doctor) will be contacted via telephone for Follow-Up assessments to review the following:

- Mortality status
- Adverse event follow up if necessary (USADE, UADE, SAE, ADE and AE)

#### 14.10 Follow-Up - Hospitalization/Discharge Beyond 12 months

Subjects with SAEs, SADEs, or USADEs or heparin-related AEs at the last follow-up visit will be followed up by telephone calls, site visits, and /or additional evaluations until the safety events is stable or resolved.

## 15 Overview of Visit Assessments

### 15.1 Endotoxin Activity Assay (EAA)

The Endotoxin Activity Assay (EAA™) is a FDA approved rapid chemiluminescent immunodiagnostic test kit that contains labeled glass tubes of specific reagents and a container of liquid substrate. This assay has very high sensitivity and specificity for endotoxin and has demonstrated a strong clinical signal with a subject's clinical status and future outcome.

Whole blood is collected in a standard 3 ml capacity hematology collection tube containing an EDTA anti-coagulant. The EAA assay required 1.0 ml of whole blood. The remaining whole blood sample will be discarded. A total of 24 ml of whole blood will be collected for the EAA assay over a 28 day period.

The results of this test will remain blinded except for the initial results that are obtained during screening. The results of this test (except the test results necessary to determine eligibility) will be kept in a secure location in the laboratory and will not be accessible by the clinical staff until all subjects in the study have completed 28 days of assessments.

The Study Operations Manual for the protocol will contain the approved instructions for performing the EAA.

### 15.2 Microbiology Culture Reports

Every effort will be made to ensure that there is adequate information to demonstrate the presence of infection, and to document the site of infection, causative organism (coded for the purposes of recording in the case report form(CRF)), sensitivity profile of the causative organism and all anti-infective treatments administered to the subject (recorded on the concomitant medications CRF). In addition to blood cultures, appropriate samples for



cultures may include good quality sputum samples or surgical specimens (obtained by an appropriate technique), CSF, peritoneal fluid, pleural fluid and urine collected by sterile technique. Other FDA approved/cleared diagnostic techniques such as serology and antigen detection can also be used to document infection. Collection of samples will follow standard of care for sepsis patients. The reporting of infections will follow the recommendations of the international sepsis forum consensus conference on definitions of infection in the intensive care unit. A summary is included as Appendix 1 and the full article is included in the bibliography. The CLIA certified laboratory that is to conduct these studies will be identified with a sub-investigator for a site and will be listed on the Investigator Agreement Form.

### 15.3 Acute Physiology and Chronic Health Evaluation (APACHE II) score

APACHE II is a severity of disease classification system (Knaus et al., 1985) based on 12 physiologic measurements, age of the subject and comorbid conditions. A higher score is associated with more severe disease and a higher risk of hospital death.

Physiologic signs and laboratory values used to calculate the APACHE II score must have been obtained within the 24-hour period prior to treatment initiation or since hospital admission if less than 24 hours. The APACHE II severity of disease classification system is included as Appendix 2 and a guide for its use is in the Study Operations Manual.

The physiologic signs and laboratory values used to calculate the APACHE II are obtained from the subject's medical record (source document). The date and final score of the APACHE II assessment will be recorded in the CRF for each subject.

### 15.4 Multiple Organ Dysfunction Syndrome (MODS)

Multiple Organ Dysfunction Syndrome (MODS) is the presence of altered organ function in acutely ill patients. The MOD score is a tool for calculating the severity of injury for six organ systems: respiratory (PO<sub>2</sub>: FIO<sub>2</sub> ratio); renal (measurement of serum creatinine); hepatic (serum bilirubin concentration); cardiovascular (pressure-adjusted heart rate); hematological (platelet count); and central nervous system (Glasgow Coma Score) with weighted scores (0–4) awarded for increasing abnormality of each organ systems. Scoring is performed on a daily basis and so allows a day-by-day prediction for subjects. The ventilation parameters, coma score and laboratory values used to calculate the Multiple Organ Dysfunction Syndrome score (MODS) are obtained from the subject's medical records.

The scores are calculated daily (over a 24h period) using the worst value (most points value for the scoring system). The scores will be used to quantify the severity of illness for each element as well as calculate a composite score which will form the basis of quantifying the severity of organ dysfunction. Each organ system variable is to be recorded in the CRF. The MODS scoring tool is included as Appendix 3 and the method of MOD scoring will be provided to the sites in the Study Operations Manual.

### 15.5 Acute Kidney Injury Network (AKIN) scoring system.

**AKIN stage 1** requires an abrupt reduction in kidney function:

- increase in serum creatinine (SCr)  $\geq 0.3$  mg/dL, OR
- $\geq 1.5$  x baseline, OR
- Urine output (UO)  $< 0.5$  mL/kg per hr for  $\geq 6$  continuous hours.

**AKIN stage 2:**

- increase in SCr  $\geq 2$ x baseline, OR
- UO  $< 0.5$  mL/kg per hr for  $\geq 12$  hr

**AKIN stage 3:**

- increase in SCr  $\geq 3$ x baseline, OR
- SCr  $\geq 4.0$  mg/dL with an acute rise of at least 0.5 mg/dL, OR
- UO  $< 0.3$  mL/kg per hr for  $\geq 24$  hr or anuria  $\geq 12$  hr

The staging is based on determining the **baseline creatinine**. Baseline serum creatinine is defined as the closest outpatient value prior to the current hospitalization that is obtained no more than 180 days before the admission date for the current hospitalization. If such a value is not available, the first serum creatinine obtained during the current hospitalization will be used as the baseline value.

Baseline UO is defined as the total UO (in mL) for the 24 hour period before randomization. If the subject has been in the ICU for less than 24 hours, the total UO since ICU admission will be used as the baseline value.

### 15.6 Mechanical Ventilation (MV)

Mechanical ventilation is defined as any ventilation device that delivers positive pressure ventilation through an endotracheal tube or tracheostomy tube.

A subject is considered to be off of mechanical ventilation when 24 hours have passed without the need for positive pressure ventilation.

The total number of days that the subject received mechanical ventilation will be recorded starting on Day 0 continuously through to Day 28, or hospital discharge if this occurs prior to Day 28.

### 15.7 Renal Replacement Therapy (RRT)

Renal replacement therapy techniques include peritoneal dialysis, continuous veno-venous hemofiltration (CVVH), continuous veno-venous hemodialysis (CVVHD), continuous veno-venous hemodiafiltration (CVVHDF), intermittent hemodialysis (IHD) and hybrid therapies such as slow extended daily dialysis (SLEDD).

The start and end of the RRT, and whether it is IRRT or CRRT, will be recorded each day for all subjects from baseline to Day 28. The subject is considered to be off RRT if there is an order in the subject's medical record to discontinue RRT and each 24 hours alive and off RRT after that will be counted as an RRT free day.

### 15.8 Vasopressor and Cumulative Vasopressor Index (CVI)

The use of vasopressor medications will be scored according to the CVI (below) from day 0 to 3 according to the schedule of assessments and then daily use is assessed and recorded as present or not present from Day 3 through to Day 28. The vasopressor medications are:

- a. Norepinephrine
- b. Dopamine
- c. Phenylephrine
- d. Epinephrine
- e. Vasopressin

This information will be reported for each drug on the subject's medical record.

The information on the vasopressor medications will be used to derive the Cumulative Vasopressor Index (CVI) (Trzeciak, McCoy et al. 2008).

<b>VASOPRESSOR</b>	<b>Dose range 1 Point</b>	<b>Dose range 2 Points</b>	<b>Dose range 3 Points</b>	<b>Dose range 4 Points</b>
Dopamine (mcg/kg/min)	0 < dose ≤ 5	5 < dose ≤ 10	10 < dose ≤ 15	>15
Epinephrine (mcg/kg/min)	---	0 < dose ≤ 0.05	0.05 < dose ≤ 0.1	>0.1
Norepinephrine (mcg/kg/min)	---	0 < dose ≤ 0.05	0.05 < dose ≤ 0.1	>0.1
Phenylephrine (mcg/kg/min)	---	0 < dose ≤ 0.4	0.4 < dose ≤ 0.8	>0.8
Vasopressin (units/min)	---	---	---	any dose

The CVI score (range 0-20) is an aggregate score of number and dose of all vasopressors used. The CVI score will be recorded in the CRFs for each subject on Days 0, 1, 2, 3.

For Day 3 through Day 28, daily use of vasopressors is recorded as present if the subject is receiving any of the above vasopressor medications. The subject is considered off vasopressors and therefore use recorded as not present, when 24 hours has passed without its use.

## 15.9 Medical History

### 15.9.1 Concurrent Medical Conditions and Past Medical History

Date of hospital and ICU admission, admitting diagnosis, and concurrent medical conditions will be recorded. Significant past and concurrent medical conditions including, but not limited to, chronic conditions and past major surgeries, should be recorded in the Medical History CRF page.

### 15.9.2 Documentation of Septic Shock

Signs of septic shock will be documented, including vital signs and signs of organ dysfunction, and dose and duration of vasopressor use as well as fluids administered. Results of all microbiologic cultures and other relevant laboratory tests performed at baseline, as well as the signs of infection (core temperature and WBC), and organ dysfunction, including use of vasopressors, will be recorded in the CRF.

### 15.9.3 Documentation of Infection

Microbiology culture results from all cultures performed for up to 24 hours prior to randomization through Day 28 will be recorded in the CRF.

### 15.10 Physical Examination

A complete physical examination will be performed, including examination of the skin; head, eyes, ears, nose, and throat; lymph nodes; heart, lungs, and abdomen; extremities and joints; neurological and mental status. Whenever possible, the same physician should perform the examination at each study visit. Each physical examination will include weight and height.

The findings of each examination will be recorded on the CRF. If clinically significant changes from baseline are noted, the changes will be documented on the AE CRF page. The Investigator will continue to monitor the subject with additional assessments until (1) findings have reached normal range and/or baseline status, or (2) in the judgment of the Investigator, abnormal findings are not related to the administration of study medication/device or other protocol-specific procedures. This examination will be performed by a licensed physician (or Nurse Practitioner or Physicians Assistant, where allowed by regulation).

### 15.11 Vital Signs

Systolic and diastolic blood pressure, core temperature ( $^{\circ}\text{C}$ ), respiratory rate, and heart rate will be measured by the standardized methods used by the institution.

Recording of oxygenation variables,  $\text{PO}_2$ ,  $\text{FiO}_2$  and  $\text{O}_2$  saturation will be included with the vital signs assessments. Note:  $\text{O}_2$  saturation may be obtained from electronic monitor.

### 15.12 Electrocardiograms (ECG)

A 12-lead ECG will be performed according to the timepoints in the schedule of assessments. At baseline, an ECG will be conducted for each subject, and results will be evaluated by the study site Investigator. A second ECG at Day 28/End of Study will be performed.

All study ECGs will be read by the Investigator at the time they are performed to determine if there are any acute safety concerns. The ECG assessment will include standard comments on Normal/Abnormal, Rhythm, Arrhythmia, Conduction, Morphology, Myocardial Infarction, ST Segment, T Wave, and U Wave observations. Interval measurements for the R-R, PR, QRS and QT for each of the pre-dose ECGs will be determined and the average of the 3 readings for each interval will be considered the "baseline" value for the subjects for which post-dose (Day 28) readings will be compared.

### 15.13 Laboratory Assessments

Scheduled blood collections for routine laboratory evaluation will occur at the times indicated in the Schedule of Assessments. Samples used for clinical laboratory determinations should be collected as per the standard of care routine of each institution. Additional samples may be collected at the investigator's discretion per standard of care.

Each EAA blood collection will require an EDTA anti-coagulated blood collection tube with a 3 ml capacity (standard hematology collection tube). The total blood collection over the 28 day period is expected to be approximately 24 ml for the EAA tests.

The blood collection for the safety laboratory assessments over the 28 day period will total approximately 72 ml. Blood samples will be appropriately processed by the institutions central laboratory facility and laboratory reports will be made available to the investigator in a timely manner to assure appropriate clinical review.

#### 15.13.1 Hematology/Chemistry/Coagulation

The following tests will be performed and results provided in the laboratory reports for the study.

On Days 1, 2, 3 and on Day 28 (or hospital discharge), all of the indicated parameters are required and should be collected within the intervals specified in the Schedule of Assessments and reported in the CRF.

On Days 7, 14, and 21, the parameters indicated below are only required if the parameter is part of the sites' standard of care and if the collection was completed within the interval specified in the Schedule of Assessments.

**Hematology:** Hemoglobin (Hgb), hematocrit (HCT), WBC with differential, RBC, and platelets.

**Chemistry:** Glucose, total protein, blood urea nitrogen (BUN), creatinine, aspartate aminotransferase (AST), alanine aminotransferase (ALT), alkaline phosphatase, total bilirubin, and electrolytes (i.e., sodium, potassium, calcium, chloride, phosphate, bicarbonate).

**Coagulation:** Prothrombin time (PT), activated partial thromboplastin time (APTT)

#### 15.13.2 Urinalysis

An assessment of urine volume (output) is to be made at the scheduled time of the renal assessments on days 1, 2, and 3.

At baseline and on day 28 (day of discharge) urine samples will be tested for glucose, protein, ketones, blood, leukocyte esterase, nitrite bilirubin, and urobilinogen.

#### 15.13.3 Pregnancy Test

Female subjects of child-bearing potential will have a routine urine pregnancy test at baseline. The pregnancy test (blood or urine) for the study must have a sensitivity for human chorionic gonadotropin (hCG) of at least 25 mIU/ml.

#### 15.13.4 Biohazard Containment

As the transmission of HIV and other blood-borne pathogens can occur through contact with contaminated needles, blood, and blood products; appropriate blood and secretion precautions will be employed by all personnel in the drawing of blood and shipping and

handling of all specimens for this study, as currently recommended by the Centers for Disease Control and Prevention and the National Institutes of Health.

#### 15.14 Mortality Status and Disposition

The following information will be collected at discharge, at Day 28 (if discharge is prior to Day 28) and at 90 days, 6 months and 12 months (Follow-Up):

- Mortality status
- AE assessments if ongoing from previous visits.

### 16 **Efficacy and Safety Outcomes**

The following study outcomes will be evaluated to compare the subjects that remained on the standard of care compared to those that received the standard of care plus the PMX cartridge.

- Primary efficacy outcome is the mortality of the subjects at 28 days.
- The primary safety outcome is the overall safety of the patients as assessed by the changes in laboratory chemistry and hematology parameters, and physical examinations including vital signs over 28 days.

Additional secondary outcomes for the assessment of efficacy will include:

- Changes in the endotoxin level as measured by the EAA between the treatment groups as measured from baseline to 12 hours after completion of treatment (defined as 2 administrations of PMX cartridge or sham treatment)
- Change in cumulative vasopressor index (CVI) from baseline to 72 hours (Day 3)
- Comparison of the number of days alive and free of the following from Day 0 through Day 28:
  - Renal Replacement Therapy
  - Mechanical ventilation
  - Vasopressor use
- Comparison of the changes in renal function from Baseline to 72 hours (Day 3) after completion of therapy:
  - Urine output
  - serum creatinine
  - Need for RRT
- Mortality at 90 days, 6 months and 12 months
- Comparison of the mean number of days spent in the hospital by subjects in each group for survivors to Day 28
- Number of subjects with SAEs or USAEs in each treatment group from Day 0 to Day 28
- Survival time from baseline to death within 28 days
- Survival time from baseline to death within 90 days.

## 17 Safety Information

### 17.1 Warnings and Precautions

Refer to Package Insert for PMX Cartridge (**TORAYMYXIN PMX-20R Extracorporeal Hemoperfusion Cartridge**) for guidance regarding the warnings and precautions of PMX cartridge handling, storage and use.

### 17.2 Pre-treatment Conditions

For the purposes of this study, any sign (including an abnormal laboratory result, as determined by the investigator) or medical diagnosis noted by medical personnel, or symptom reported by the subject that occurs prior to the initiation of first treatment is considered to be a pre-dosing sign/symptom.

### 17.3 Definitions Adverse Events (AE) and Serious Adverse Events (SAE):

#### 17.3.1 Definition of an Adverse Event (AE)

An Adverse Event (AE) is any untoward medical occurrence in a subject receiving an investigational product, which does not necessarily imply a causal relationship with treatment. An AE includes any unfavorable and unintended sign that could include a clinically significant abnormal laboratory finding, symptom, or disease temporally associated with the use of the study product, whether or not considered related to the study product.

Note that an equivalent term for an AE suspected to have been caused by an investigational device is *adverse device effect*, or *ADE*.

#### 17.3.2 Definition of a Serious Adverse Event (SAE)

A Serious Adverse Event (SAE) is an adverse event that results in any of the following outcomes:

- Death
- A life-threatening condition (with immediate risk of dying)
- Prolongation of existing hospitalization, or subsequent inpatient hospitalization
- Requiring intervention to prevent permanent impairment/damage
- A persistent or significant disability/incapacity
- A congenital anomaly/birth defect in the offspring of a subject

Important medical events that may not result in death, be life-threatening, or require hospitalization may be considered serious adverse events when, based upon appropriate medical judgment, they may jeopardize the subject and may require medical or surgical intervention to prevent one of the outcomes listed above.

In addition, anaphylactoid reactions and cardiac arrhythmias such as atrial fibrillation, heart block, ventricular tachycardia, and ventricular fibrillation should be considered serious if in



the investigator's opinion, the condition is related to use of the study device and may lead to discontinuation of the hemoperfusion.

### 17.3.3 Definition of Serious Adverse Device Effects (SADE)

A Serious Adverse Device Effect (SADE) is any adverse effect on health and safety or any life-threatening problem or death caused by or associated with a device, but does not meet the criteria of *unanticipated* or *unexpected*.

- The most common anticipated device related events are the following:
  - Elevation of inlet pressure
  - Bubble generation
  - Cartridge leak
  - Cartridge break
  - Cartridge clotting
  - Suspended substance

See also Sections 10, 10.2, and 10.4 and Reports of Prior Investigations Document.

### 17.3.4 Definition of Unanticipated Serious Adverse Device Event (USADE)

An Unanticipated Serious Adverse Device Effect (USADE) is any SADE not previously identified in nature, severity or degree of incidence in the protocol, Instructions for Use, Summary of Previous Studies Document, or other sources of information for the PMX cartridge. (See also Sections 10, 10.2, and 10.4). Additionally, a USADE is any other unanticipated serious problem associated with the investigational device that relates to the rights, safety, or welfare of subjects.

## 17.4 Collection of Safety Events

The safety event collection period begins upon initiation of the first randomized study treatment; i.e., PMX cartridge or sham line insertion (Day 0), and ends after the completion of the End of Study/ Early Termination visit (Day 28). Thereafter, any SAE, SADE, or USADE that may occur is to be collected and reported to the Sponsor up to the follow-up visit at 12 months after treatment.

SAE reporting is NOT required for subjects who have signed an EAA informed consent or combined informed consent (both EAA and Study Specific Informed Consents) and EAA is < 0.6 or that the EAA is  $\geq 0.6$  but the subject does not go on to randomization to study treatment. For subjects whose randomized treatment has been initiated, SAE reporting is required, as indicated in the above paragraph. This refers only to events that are serious and result in death or are serious and are unrelated to the underlying condition.

The following adverse events will be collected:

- Significant AEs that may be heparin-related, in particular:

- Events with signs or symptoms consistent with anaphylactic-type reactions, acute hypotension, and/ or acute gastrointestinal distress
  - Any other serious reaction which may be attributed to the heparin in a medical product, included but not limited to:
    - Unexplained thrombocytopenia
    - Excessive anticoagulation or hemorrhage
    - Inadequate anticoagulation
    - Unexplained or premature thrombosis of a heparin-coated device
    - Spurious results of in-vitro diagnostic tests that utilize heparin either as part of the assay or as part of the specimen collection
- SAEs
  - Anticipated SADEs
  - USADEs
  - Non-serious AEs the investigator deems to be directly related to the use of the investigational device

**Note:** The following are not considered clinical outcomes of severe sepsis but adverse events, and will be collected:

- Arrhythmias, such as atrial fibrillation, heart block, ventricular tachycardia, and ventricular fibrillation

### 17.5 Documenting Safety Events

Any AE, SAE, SADE, or USADE as described above that occurs during the study must be documented in the subject's medical record (source document), in accordance with the investigator's normal clinical practice, and on the appropriate CRFs. The investigator will be asked to define the AE using the Common Terminology Criteria for Adverse Events (CTCAE) and assess the severity of the AE using the following categories: Grade 1, Grade 2, Grade 3, Grade 4 and Grade 5 based on the common terminology criteria (CTCAE available online at <http://safetyprofiler-ctep.nci.nih.gov/ctc/ctc.aspx>).

To maintain the blind, AEs that occur while the subject is being prepared for use of the investigation device and when the device is being administered and qualify for collection will be recorded on the CRF by a designated sub-investigator. These AE pages will also be reviewed and signed by the sub-investigator. The sub-investigator will be a designated health care professional that is listed on the Investigator Agreement Form and has this responsibility designated by the site's principal investigator.

## 17.6 Follow-Up of Safety Events

Please refer to Sections 14.9 and 14.10. The investigator is responsible for ensuring that follow-up includes any necessary supplemental investigations to elucidate the nature and/or causality of the event. This may include additional laboratory tests or investigations, histopathological examinations, or consultation with other health care professionals.

Sponsor requests that each study investigator perform or arrange for the conduct of any necessary supplemental measurements and/or evaluations. If a subject dies during the study or follow-up, Spectral Diagnostics requests a copy of any post-mortem findings, including histopathology will be provided if available.

## 17.7 Prompt Reporting of Safety Events to Sponsor

The following safety events are to be promptly reported to the Amarex Safety Department within 24 hours of the Investigator's first knowledge of the event (or at the latest, on the following working day), even if the event does not appear to be related to the study device:

- SAEs
- USADEs
- Significant AEs that may be heparin-related

These events will be reported on the Safety Event Form provided in the Study Operational Manual. All Adverse Event Report Forms will include a detailed description of the event(s). Copies of medical records other than post-mortem findings or histopathology reports of events that result in death will not be provided with the form, unless specifically requested by Amarex.

**Complete Safety Event Form and fax (or scan and e-mail) to:**

**Fax: 240-454-6602**

**E-mail: [saereporting@amarexcro.com](mailto:saereporting@amarexcro.com)**

The Sponsor is responsible for reporting the following to the FDA and will ensure that all reporting requirements are met:

- All SAEs, including those that are USADEs, that are serious, unanticipated/unexpected and related
- All USADEs that are not AEs but are other unanticipated serious problems associated with the investigational device that relates to the rights, safety, or welfare of subjects
- All significant AEs that may be heparin-related.

The Investigator is responsible for reporting all USADEs to the IRB as soon as possible and within 10 working days after the Investigator first learned of the effect. The Investigator is responsible for reporting SAEs to the IRB according to the IRB's requirements.

### **17.7.1 Regulatory Reporting Requirements for Sponsors**

The following reports are required by the Sponsor under CFR §812.150 and 21 CFR 312.32. All reports to FDA should be identified as IDE Supplements and submitted in triplicate.

#### **17.7.1.1 Unanticipated Serious Adverse Device Effects**

The Sponsor must report the results of an evaluation of an unanticipated adverse device effect to the FDA, all reviewing IRBs, and investigators within 10 working days after the Sponsor first receives notice of the event.

#### **17.7.1.2 Withdrawal of IRB Approval**

The Sponsor must notify the FDA, all reviewing IRBs, and participating investigators of the withdrawal of IRB approval of an investigation (or any part of an investigation) within 5 working days of receipt of the withdrawal of approval.

#### **17.7.1.3 Withdrawal of FDA Approval**

The Sponsor must notify all reviewing IRBs and participating investigators of any withdrawal of FDA approval within 5 working days after receipt of the notice.

#### **17.7.1.4 Current List of Investigators**

Every six months the Sponsor must submit to the FDA a current list of the names and addresses of all investigators participating in a significant risk device investigation.

#### **17.7.1.5 Progress Reports (or Annual Reports)**

At regular intervals (at least yearly) for a significant risk device, the Sponsor must provide progress reports to the FDA and all reviewing IRBs.

#### **17.7.1.6 Recalls and Device Disposition**

The PMX cartridge and sham kits utilized in this study is a one-time use product and will be destroyed at the investigator site after normal use.. Any unused investigation product/device will be returned to the assigned vendor or destroyed on site as instructed in the Study Operations Manual. The Device Disposition will be tracked by the site Pharmacy using an Investigational Product Accountability Log and the IP kits may not be destroyed without written approval from the monitor/CRA, the nephrologists and the pharmacist using an Investigational Product Destruction Log (see section 13.7.1 Investigational Device Accountability and Reconciliation). The Sponsor will notify FDA and all reviewing IRBs of any request from the Sponsor that an investigator return any unit of an investigational device due to malfunction, or results in an adverse event that is both serious and unexpected. The Sponsor will notify FDA and all reviewing IRBs of any request from the manufacture (Toray) of the PMX device or from the Sponsor (Spectral Diagnostics, Inc) of any recall of the PMX cartridge. The notice must be made within 30 working days after the request is made and must state why the request was made.

#### **17.7.1.7 Final Report**

For a USADE, the Sponsor must notify the FDA and all reviewing IRBs within 30 working days of the completion or termination of the investigation. The Sponsor must also submit a final report to FDA and all reviewing IRBs and participating investigators within 6 months after the completion or termination of the investigation. For a non-significant risk device, the Sponsor must submit a final report to all reviewing IRBs within 6 months after completion or termination.

#### **17.7.1.8 Informed consent**

Sponsors must submit a copy of any report by an investigator of the use of a device without first obtaining informed consent. The report must be made to the FDA within 5 working days after receipt of the notice of such use.

#### **17.7.1.9 IRB Significant Risk Device Determination**

If an IRB determines that the device is a significant risk device and not a non-significant risk device as the Sponsor had proposed to the IRB, a report must be submitted to the FDA within 5 working days after the Sponsor learns of the IRB's determination. The PMX cartridge is a significant risk device.

### **17.8 Emergency Procedures**

In the event of an emergency (i.e. an event that requires the Sponsor (or its designee (Amarex) immediate attention regarding the treatment of the subject, operation of the clinical study, and/or use of the investigational device, clinical site personnel will immediately contact the Medical Monitor.

#### **17.8.1 Emergency Unblinding**

To maintain the trial's blind, an unblinded team of nephrology staff, ICU bedside nurse and a pharmacist will be trained to use the PMX cartridge on those subjects randomized to the PMX cartridge group. However, to maintain the blind the unblinded team will not assess any subjects clinically. However for the need for emergency unblinding, members of this staff may be contacted on agreement from the Medical Monitor to disclose the blinding of individuals.

## **18 Premature Termination of Treatment**

### **18.1 Study Discontinuation**

Every effort within the bounds of safety, and subject choice, should be made to have each subject complete the study. The investigator may terminate a subject's participation at any time for reasons such as adverse events, intercurrent illness, noncompliance with study procedures, serious eligibility or on-study protocol violations, or in the best interests of the subject, in the opinion of the investigator. Subjects are also free to withdraw their consent at any time during the study.

The reason for discontinuation from the study (adverse event, worsening of pathology, protocol violation, withdrawal of consent, need for a prohibited treatment, lost to follow-up, or other reason) should be recorded in detail on the final visit CRF.

In case of significant disease or intolerance of study medication, the decision to stop treatment for a given subject can be made by the investigator alone. If such a treatment discontinuation occurs, the investigator will notify Amarex and provide medical justification.

At the time of withdrawal the investigator will complete the End of Study/Early Termination Assessments and CRF (Day 28) including mortality information. Reasonable efforts will be made to collect the data required to assess the mortality outcome at for all subjects who withdraw early as assessed by the assessments normally made on Day 28, with the exception of those who have withdrawn consent. The mortality information attempted to be collected will include information that is on the SAE CRFs including, but not limited to date of death, and cause of death.

Clinical investigators who are faced with an ethical problem during the trial should immediately inform the Sponsor or the Medical Monitor.

## 18.2 Withdrawn for Safety

A subject withdrawn from the study will continue to be followed for safety unless lost to follow-up.

## 18.3 Sponsor's Actions

The Sponsor reserves the right to interrupt the study at any time whatsoever in the event of:

- Inappropriate or slow recruitment of subjects
- On-going problems with data quality
- Major problems with tolerance or efficacy of the investigational device;
- The decision by the Sponsor or investigator that it is not appropriate to permit an individual study site to continue enrollment OR
- At the request of Health Authority or IRB

## **19 Statistical Considerations**

### 19.1 Data Collection and Management

Paper case report forms (CRFs) will be used for this study. Data monitors will verify the data, making queries directly to the sites when necessary. Data will be first reviewed through a check for logical and obvious correction errors. Double data entry will be implemented to reduce the possibility of errors due to human entry. Investigators will respond to queries by updating the CRFs. After all queries have been resolved, the Data Monitor will lock the database according to Amarex's Data Management's SOP. Final audit

reports addressing all queries and their resolution will be generated from the Data Management System and stored at each study site.

At the conclusion of the study, the data will be stored with the Sponsor or a designated party.

## 19.2 Sample Size Determination

Subjects in ICUs will be assessed for septic shock and the presence of an elevated endotoxin level ( $\geq 0.60$  EAA units) using the Endotoxin Activity Assay. For subjects who meet the inclusion criteria and consent to participate in the study, a mixed randomized block design with block sizes of 2 and 4 (stratified by study sites) will be used such that each subject will be equally likely assigned to either the arm of standard medical care alone or the arm of standard medical care plus the PMX cartridge. To maintain the treatment blind, a team of nephrology staff will be trained to use the PMX cartridge on those subjects randomized to the PMX cartridge arm. However, these nephrologists will not assess any subjects clinically and will make every effort to ensure that the integrity of the blind is maintained. The training of the unblinded health care personnel will include avoiding discussions with subjects, colleagues or other study personnel. In addition they will have a set of unblinded CRFs that will be used to record study information. These CRFs will be signed by an unblinded sub-investigator.

The power analysis is based on a two-sided Fisher's exact test (Agresti 1990) to compare the proportions of death within 28 days between the standard medical care plus the PMX cartridge and the standard medical care alone in subjects with endotoxemia and septic shock. The assumptions used for the calculation of sample size are a treated mortality of 37.5 % based on data from the EUPHAS 2 Registry. We assumed that for the control arm of standard medical care alone; approximately 58.5% subjects will die by Day 28 after the baseline visit. It is also hypothesized that there is an approximately 21% improvement in 28-day mortality rate for subjects who receive the standard medical care plus the PMX cartridge, as compared to those receiving the standard medical care alone. The overall significance level for the entire sequence of primary efficacy tests is assumed at 5%.

Assuming a sample size ratio of 1:1 between the two study arms, a sample of 104 subjects per study arm (i.e., a total of 208 subjects for both arms) provides sufficient power to detect the hypothesized effect size from the final primary efficacy test.

## 19.3 Definition of Study Population for Analysis

The Intent-to-treat (ITT) population is defined as all subjects that have been randomized to receive either PMX treatment or the sham treatment. The primary analyses population will be subjects randomized after 9April2014.

The safety population is defined as all subjects who have signed informed consent for treatment randomization and for whom treatment has been initiated. Treatment initiation is defined as the start of placing the central line for treatment.

The Per Protocol (PP) patient population is defined as the subjects that have received both treatments with the PMX cartridge or sham treatments and did not have any major protocol violations.

#### 19.4 Comparability of Subjects at Baseline

Baseline measures are defined as measurements obtained between the screening visits and before the subject has been randomized into the double-blind treatment phase. Baseline demographics and subject characteristics will be summarized by treatment group using descriptive statistics. For categorical variables, counts and proportions of subjects within each study arm will be computed and presented. For continuous variables, the numbers of subjects, means, standard deviations, quartiles, minimums, and maximums will be calculated and presented. Any significant imbalances between the study arms at baseline will be considered in the analysis.

#### 19.5 Efficacy Variables and Analysis

Primary efficacy analyses will be conducted on the intent-to-treat population that contains all subjects randomized after 9Apr2014. The primary efficacy endpoint is the simple mortality rate of the subjects within 28 days after the initiation of the treatment perfusion or the sham perfusion. Let  $P_0$  and  $P_1$  be the proportion of death within 28 days for the arm of standard medical care alone and the arm of standard medical care plus the PMX cartridge, respectively. The primary efficacy analyses will test the null hypothesis of  $H_0 : P_1 = P_0$  against the two-sided alternative hypothesis of  $H_a : P_1 \neq P_0$ . The test of these hypotheses will be carried out through Fisher's exact test (Agresti 1990). A 5% significance level will be assumed for the primary efficacy test. PROC FREQ/SAS (Inc. 1990) will be used to implement the analyses. Similar analyses on the primary efficacy endpoint will also be conducted on the Per Protocol (PP) population.

As a secondary analysis, we will also compute the survival time from the initiation of the treatment perfusion or the sham perfusion to death within 28 days and compare the risk of death between the two study arms. For these subjects who are still alive after Day 28, their survival time will be treated as statistically censored at Day 28. For those subjects who drop out of the study or are lost to follow-up within 28 days of the baseline, their survival time will be treated as statistically censored at the time of their last follow-up visit. Survival distributions from the initiation of the treatment perfusion or the sham perfusion to death within 28 days will be estimated by the Kaplan-Meier product limit estimator (Kalbfleisch 1980). The survival comparison between the arm of standard medical care alone and the arm of standard medical care plus the PMX cartridge will be based on a log-rank test at a significance level of 5% (Kalbfleisch 1980). An asymptotic 95% confidence interval estimate to the difference of 28-day mortality rate between the two study arms will be obtained. Another asymptotic 95% confidence interval to the hazard ratio of death between the two study arms will also be obtained. These analyses will be implemented by PROC LIFETEST/SAS and PROC PHREG/SAS (Inc. 1990). Other secondary efficacy analyses will be conducted similarly to compare the survival distributions between the two study arms



within 90 days of the initiation of the treatment perfusion or the sham perfusion. Similar secondary efficacy analyses will also be conducted on the subject population that contains all randomized subjects with at least one post-treatment efficacy assessment as well as the Per Protocol (PP) population.

More secondary efficacy analyses will compare the time (i.e., the number of days) subjects spend in the hospital between two treatment groups among these who will survive to Day 28. This analysis will be conducted in a similar fashion as the primary efficacy comparison described above (i.e., to analyze the number of days from the initiation of the treatment perfusion or the sham perfusion to the time of hospital release within Day 28 by treating the time of hospitalization for these who either dropped out within Day 28 or stayed in hospital for the entire 28 days as statistically censored). PROC LIFETEST/SAS and PROC PHREG/SAS (Inc. 1990) will be used to implement these analyses. A similar method to determine number of days subjects spend in hospital will be used for the 90 day, 6 month and 12 month assessments.

Additional secondary efficacy analyses will be carried out on several secondary efficacy endpoints. First, to assess if two uses of the PMX cartridge decrease endotoxin levels, as measured by the Endotoxin Activity Assay (EAA) in the treated group compared with the control group, a general linear mixed effects model (Milliken 1992) will be used to analyze the repeatedly measured EAA level (Day 0, Day 1, and Day 2 and Day 3). This model will contain a fixed effect of the treatment groups (standard medical care alone vs. standard medical care plus the PMX cartridge) and another fixed effect of time (Day 0, 1, and 2, treated as a classification variable) as well as their possible interactive effects. The model will also contain a random effect of the study sites. An unstructured covariance structure between repeatedly measured EAA levels within same subjects will be used in the model (Milliken 1992). For this analysis, the primary interest will be the comparison of treatment groups on the mean difference of EAA levels between Day 0 and Day 3. Point estimates, as well as 95% confidence interval (CI) estimates to the mean difference of EAA level between Day 0 and Day 3, will be obtained for each study group through appropriate contrasts. The efficacy comparison between the two study groups will be achieved by statistically testing the interactive effect between the treatment groups and the measurement times (restricted to Day 0 and Day 3) through an appropriate contrast based on the model. A 95% confidence interval (CI) estimate based on the model for the mean difference between the two treatment groups will also be computed to assess the magnitude of the group difference on the change of EAA level from Day 0 to Day 3. All tests and CIs involved in these analyses will be two-sided. These analyses will be performed by PROC GLM/SAS (Inc. 1990) and PROC MIXED/SAS (Little 1996).

As a sensitivity analysis, we will also directly compute the change from Day 0 of EAA level at Day 3 for each subject (Day 2 observation will be carried forward if Day 3 observation is missing) and analyze it through another general linear mixed effects model (Milliken 1992). This model will contain a fixed effect of the treatment groups (standard medical care alone vs. standard medical care plus the PMX cartridge) and another fixed effect of the baseline measurement on the EAA as well as a random effect of the study sites. Point estimates, as

well as 95% confidence interval (CI) estimates to the adjusted mean change from the baseline, will be obtained for each treatment group. The efficacy comparison between the two treatment groups will be achieved by statistically testing the fixed effect of study groups based on the model. A 95% confidence interval (CI) estimate based on the model for the mean difference between the two study groups will also be computed to assess the magnitude of the group difference on the change of EAA level from Day 0 to Day 3. All tests and CIs involved in these analyses will be two-sided. These analyses will be performed by PROC GLM/SAS (Inc. 1990) and PROC MIXED/SAS (Little 1996).

Similar analytic and sensitivity approaches (as described for the analyses of EAA level) will be used to perform the following secondary efficacy analyses:

- To estimate the mean change in vasopressor dosage at Day 3 (over the preceding 72h) from the baseline level, as measured by the Cumulative Vasopressor Index (CVI) for each study group and compare these changes between the two study groups;
- To estimate the mean change in mean arterial pressure (MAP) at Day 3 from the baseline level for each study group and compare these changes between the two study groups;
- To estimate the mean change in the total Multiple Organ Dysfunction Score (MODS) as well as the organ-specific component score of the scale at Day 3 from the baseline level for each study group and compare these changes between the two study groups;

The need for renal replacement therapy (RRT) will be assessed daily in a binary scale (yes or no) from Day 0 to Day 28 for all randomized subjects (ITT population). Days alive and free of RRT (within 28 days) since the initiation of the treatment perfusion or the sham perfusion will be analyzed by a general linear mixed effects model containing the fixed effect of the treatment groups (standard medical care alone vs. standard medical care plus the PMX cartridge) and a random effect of the study sites (Milliken 1992). Point estimates, as well as 95% confidence interval (CI) estimates to the mean number of days alive and free of RRT will be obtained for each treatment group. The efficacy comparison between the two treatment groups will be achieved by statistically testing the fixed effect of study groups based on the model. A 95% confidence interval (CI) estimate based on the model for the mean difference between the two study groups will also be computed to assess the magnitude of the group difference on the mean number of days alive and free of RRT.

Similar analytic approaches will be used to analyze and compare days alive and free of mechanical ventilation and days alive and free of vasopressor use (within 28 days) between treatment groups.

In addition a long term follow up of survival status at 90 days, 6 months and 12 months will be undertaken. This will entail a simple comparison of survival rates for randomized subjects 90 days, 6 months and 12 months after the initiation of the treatment perfusion or the sham perfusion.

## 19.6 Safety Data

Safety data, including adverse events, vital signs, clinical chemistry, hematology, and urinalysis will be summarized descriptively for each treatment group and for the entire safety population. These summaries will be provided for safety measurements at each individual time point as well as longitudinally for the change from the baseline. Descriptive statistics, including mean, standard deviation, median, minimum and maximum values will be presented for continuous variables. Frequencies and percentages will be presented for categorical variables. Listings will summarize safety data as appropriate. Treatment group differences will be assessed with t-test or Wilcoxon test for the continuous variables and Fisher's exact test for categorical variables.

Adverse events will be coded using the current version of the MedDRA dictionary and will be summarized by treatment group, system organ class (SOC) and preferred term for both the number of subjects reporting the AE and the number of AEs reported. A by-patient AE data listing will be presented and include verbatim terms, SOC terms, preferred terms, treatment group, severity, and relationship to treatment.

Adverse events will be summarized by counts and percentages in each body system, overall, as well as, in each coding term by treatment group. AEs, USADEs and SADEs considered at least possibly related to the investigational device will be further tabulated by treatment group. Adverse events leading to the interruption or discontinuation of study or use of the investigational device will be summarized by treatment group in either a listing or summary table. Differences in the occurrences of AEs and USADEs and SAEs between the groups will be tested with the Fisher exact test and those with a p-value <0.05 will be noted. Summary statistics of laboratory parameters (e.g., laboratory chemistry and hematology parameters) will be summarized using the number of observations, mean, standard deviation, minimum, lower quartile, median, upper quartile, and the maximum.

### 19.6.1 Routine Monitoring of the Trial's Status:

Safety including mortality data will be reviewed by the Data Safety and Monitoring Board (DSMB) at intervals of up to 3 months to assess the risk/benefit balance of the trial. The trial will have one safety analysis and one interim efficacy analysis in the primary endpoint (i.e., Day 28 mortality rate), followed by the final primary efficacy analyses after all randomized subjects have completed their Day 28 assessment or discontinued from the study. Further information regarding the two planned interim analyses may be found in Section 19.8.1 Interim Analyses.

A data package will include summary information regarding enrolment, demographics, safety, efficacy, and any additional information the DSMB may request. These tables and analysis will be presented to the DSMB in a manner that identifies treatment groups.

## 19.7 Missing data

The missing data will be analyzed through sensitivity analyses. The proposed primary efficacy analyses on the survival time after baseline will provide valid statistical inferences when the censoring mechanism is independent of the survival time (Inc. 1990). The

proposed general linear mixed effect models on secondary efficacy endpoints will produce valid statistical inferences when the missing data are missing at random (MAR)(Milliken 1992). Sensitivity analysis for the missing data (e.g., through imputation of last observation carried forward (LOCF) for subjects who dropped out or lost to follow-up before the designated time point for the analyses) will be evaluated and analyses results compared among different analytic approaches.

## 19.8 Sequence of Planned Analyses

### 19.8.1 Interim Analyses

Two interim analyses will be performed by a statistician independent of the DSMB and the Sponsor. The first interim will be for safety (after approximately 76 treated subjects; i.e., 20% of the planned population, have completed the 28-day post-treatment observation period or have died, whichever occurs first) and the second will be for efficacy (after approximately 184 treated subjects; i.e., 50% of the planned population have completed the 28-day post-treatment observation period or have died, whichever occurs first). The second interim analysis will have pre-defined stopping rules which will be specified in both the Statistical Analysis Plan and the DSMB charter. Interim analysis reports will be provided to the DSMB, as specified in the Statistical Analysis Plan and the DSMB charter. Alpha for the final analysis will be adjusted as described in the Statistical Analysis Plan.

### 19.8.2 Final Analysis and Reporting

If the trial is terminated by the results of interim analysis or by the recommendations of the DSMB, the final efficacy and safety analyses will be performed using entire data of follow-up to 12 months until the last assessment for all subjects randomized prior to the study termination date.

If the trial is not terminated by the interim analysis, the final analysis will be performed when all randomized subjects have completed their Day 28 assessment or discontinued from the study. The final analysis will evaluate both safety and efficacy variables as described above and will be performed on a locked database that has passed a QA assessment. The safety analysis will be carried out on safety variables using the entire data of follow-up until the last assessment for all subjects randomized. Although a long term follow up of survival status at 90 days, 6 months and 12 months will be undertaken, the final efficacy analyses on Day 28 mortality rate will be considered primary, and those on Day 90 mortality rate and 6 month and 12 month mortality rates as well as on other efficacy endpoints will be considered secondary.

To account for the interim analysis, the nominal significance level used for testing the efficacy of the PMX cartridge in the final analysis is detailed in the SAP, to protect the trial-wise type 1 error of 0.05.

The report of final analyses will be submitted to the FDA.

## **20 Administrative Aspects**

### **20.1 Data Quality Assurance**

The Sponsor (or its designee Amarex) will perform quality control and assurance checks for this study. Before enrolling any subjects into this study, Sponsor personnel (or its designee Amarex) will review the following with the investigator and study personnel:

- Final protocol
- Package Insert (Instructions for Use) for the investigational device
- CRFs and instructions for their completion
- The procedure for obtaining informed consent(s), and
- The procedure for reporting AEs (defined in Section 17)
- Supplemental study-related materials, manuals, etc.

A qualified representative of the Sponsor (or its designee Amarex) will monitor the conduct of the study by visiting the site and by contacting the site by telephone. During the on-site monitoring visits, information recorded on the CRFs will be verified 100% against source documents for all enrolled subjects. After Data Management receives the CRFs, the data will be entered into the database using a double data entry procedure. The Medical Monitor will review the data for safety information. The Sponsor's (or its designee Amarex) clinical data associates will review the data for legibility, completeness, and logical consistency. Additionally, the Sponsor's (or its designee Amarex) clinical data associates will use automated validation programs to help identify missing data, selected protocol violations, out-of-range data, and other data inconsistencies. Requests for data clarification or correction (queries) will be forwarded to the investigative site for resolution in the form of a Data Clarification Form (DCF). A sample set of records from the final database will be fully audited against the corresponding CRFs.

### **20.2 Institutional Review Board (IRB) Approval**

The protocol and the informed consent forms must have initial IRB approval prior to study initiation and continuing review/approval at least annually thereafter (when required). The signed IRB approval letter must identify the documents approved (i.e., list the investigator's name, the protocol number and title, the date of the protocol and informed consent document, and the date of approval of the protocol and the informed consent document). All written information that will be provided to the subject and any advertisement used to recruit subjects (if applicable) must also be reviewed and approved by the IRB. The Sponsor will not ship clinical supplies to the site until a signed approval letter from the IRB has been received and a contractual agreement (CTA) has been signed by the Sponsor (or its) and the clinical site.

The investigator must also notify the IRB of USADEs/SAEs, as per local IRB requirements.

### 20.3 Independent Ethics Committee or Institutional Review Board

This protocol and subject informed consent form must be reviewed and approved by an IRB complying with the requirements of 21 CFR 50 and the ICH guidelines before enrollment of subjects. Amarex must receive the letter or certificate of approval from the IRB prior to delivery of clinical supplies.

### 20.4 Ethical Conduct of the Study

This protocol was designed and will be conducted, recorded, and reported in compliance with the principles of Good Clinical Practice (GCP) regulations established by the basic principles defined in the ICH Guideline for Industry E6 Good Clinical Practice: Consolidated Guidance.

### 20.5 Subject Information and Informed Consent

Written informed consent is required prior to enrollment in the study. It is the responsibility of the Investigator to obtain such consent from the subject or the surrogate health care decision maker. It is necessary for the investigator to carefully seek to assess the subject's competence and decision-making capacity and, if necessary, empower a suitable surrogate to act on his or her behalf. Investigators will be expected to remain informed of and compliant with all applicable international and national authority regulations for clinical trial conduct when developing the subject informed consent. The Investigator must furnish Amarex with a photocopy of the proposed consent form prior to submitting to the IRB so that Amarex may ensure that all appropriate elements are incorporated into the document.

Upon approval by the IRB, the Investigator must furnish:

- (1) A photocopy of the approved informed consent, and
- (2) The letter stating formal approval has been granted by the IRB, prior to release of clinical supplies

Prior to conducting any procedures under this protocol, written informed consent must be obtained from the subject (or a surrogate health-care decision maker in accordance with local practice and regulations).

Informed consent will be attempted to be obtained from each subject. If the subject is incapable of providing an informed consent than an acceptable, surrogate health-related decision maker (surrogate decision maker) will be asked to sign an informed consent for the subject. Health care professionals will use local laws and regulations in their latitude in choosing between a spouse, adult children, siblings, companions, etc. States laws and local regulations have established a hierarchy of who should be the designated relative to act as surrogate if a subject has not left written instructions. A surrogate should make a treatment decision using what is called "substituted judgment" if they know what the subject would desire, or a "best interest judgment," which is based on recommendations from the health care professionals associated with the care of the subject.

If the initial written informed consent form is obtained from a surrogate decision maker, the subject must also give consent as soon as she/he is able.

Each subject (or surrogate decision maker) will sign the informed consent form(s) after having been informed of the background, benefits, risks, nature, aims, and methods of the clinical trial by the investigator. The original, signed consent form(s) will remain in the investigator's file; a copy of the fully executed consent/assent form will be given to the subject. The subject's (or surrogate's) signature will be obtained prior to performing any study-related procedures.

Confirmation of a subject's informed consent (documentation of the informed consent process) must also be documented in the subject's medical records prior to any testing under this protocol, including screening tests and evaluations.

HIPAA authorization will also be obtained from participating subjects.

These regulations are not intended to limit the authority of a physician to provide emergency medical care.

The delegation of investigator responsibilities, including informed consent, will be documented on the clinical study information form (e.g. Delegation of Authority Log).

## 20.6 Removal of subjects from treatment or assessment

Subjects have the right to withdraw from the study at any time for any reason. The investigator and Sponsor also have the right to withdraw participants from the study. Subjects may be withdrawn from the study and discontinue device treatment for any of the following reasons:

- If, in the opinion of the investigator, there is no evidence of clinical benefit to the subject.
- Subject request
- Investigator or Sponsor request, whether for administrative or other reasons
- Unacceptable Adverse Events
- Need for significant changes in medical treatment that the investigator feels would interfere with evaluations of safety and/or disease status
- Significant protocol violation, after consultation with the Medical Monitor
- Failure to adhere to the visit schedule; serious protocol violation or unreliable behavior

To the extent possible, follow-up information will be obtained for subjects who are withdrawn from the study. See The Protocol Section 17 for procedures to be performed at the follow-up visit (Day 60). An effort must be made to determine why a subject fails to complete the necessary visits or is dropped from the study. This information should be recorded on the subject's CRF.

If the reason for removal of a subject from the study is an adverse event, the specific event and any related test results will be recorded on the CRF. If an emergency occurs where the



subject's condition requires knowledge of the study device (unblinding), the randomization code may be broken for the specific subject only. Any broken code will be clearly justified and explained by a comment upon the CRF. Spectral Diagnostics must be immediately notified and the procedures for reporting AEs (as defined in Section 17) will be followed, as appropriate.

## 20.7 Case Report Forms

All data will be recorded on CRFs provided by the Sponsor (or its designee Amarex).

The unblinded nephrology team, the designated ICU staff, and the pharmacist will have a set of CRFs that will be kept separate from the other CRFs, will be monitored separately, and will be signed by the assigned sub-investigator, to ensure the blind is maintained from other study personnel. Procedures for data entry and monitoring of blinded study data are outlined in the Study Operations Manual.

The white and yellow pages from the 3-part NCR form must be returned to the Sponsor (or its designee Amarex) and the investigator must retain the pink copy for his/her file.

CRFs and other pertinent records are to be submitted to the Sponsor (or its designee Amarex) during and/or at completion or termination of the study.

The investigator also must submit all incomplete CRFs that document subject experience with the investigational device, including retrievable data on subjects who withdraw before completion of the study.

Data for analyses performed at the local labs may be processed using electronic systems.

## 20.8 Adverse Event Reporting

The investigator agrees to report all AEs to the Sponsor (or its designee Amarex) as described in the Adverse Events section. Furthermore, the investigator is responsible for ensuring that any co-investigator or sub-investigator promptly brings reportable AEs to the attention of the investigator. If applicable, the investigator also is responsible for informing the participating IRB/IEC of any SAEs/ USADEs.

Recording requirements for device effects are outlined in Appendix 6.

## 20.9 Monitoring of the Study

This study will be monitored by the Sponsor, or its designee (Amarex). Site visits are made before the study begins, at regular intervals during the study, and at the study close-out. Communication by telephone, mail, FAX and e-mail may be used as needed to supplement site visits. Adequate time and space for the monitoring of the storage, dispensing, reconciliation and review of study related records should be allocated by the investigator. The investigator (or its designee (Amarex) and study personnel will cooperate with the Sponsor, provide all appropriate documentation, and be available to discuss the study. The purpose of the site visits is to verify the following:



**Adherence to the protocol:** The investigator should document and explain any deviation from the approved protocol. Non-compliance requires immediate action and a corrective and preventative action plan should be implemented in the case of significant deviations from the protocol.

**Data monitoring:** Review of the data recorded on the CRFs for completeness, integrity and accuracy. Verification of compliance will require comparison of the source documents to the CRFs.

**Investigational device inventory management:** Adequate time and space for the monitoring of the storage, dispensing, reconciliation and review of inventory records should be allocated by the investigator.

**Compliance with regulations:** Review of the Investigator Site File (Regulatory Binder) for completeness and accuracy of Essential Documents will be performed.

**Subject safety:** Verification of proper informed consent, review of adverse events, and other data will be performed to ensure the safety and well-being of study subjects.

Processes for the monitoring of blinded and unblinded study data are outlined in the Monitoring Plan and the Study Operations Manual for this study.

#### 20.10 Review of Source Records

The investigator agrees that qualified representatives of the Sponsor, or its designee (Amarex) and regulatory agencies will have the right, both during and after this study, to conduct inspections and to audit and review medical records pertinent to the clinical study as permitted by the regulations. Subjects will not be identified by name, and confidentiality of information in medical records will be preserved. The confidentiality of the subject will be maintained unless disclosure is required by regulations. Accordingly, the following statement (or similar statement) will be included in the ICF:

“Representatives of regulatory agencies, IRBs, the Sponsor, and your personal physician may review your medical records and all information related to this study as permitted by law. Identifying information will not appear on any record received by the Sponsor. Your identity will remain confidential unless disclosure is required by law.”

#### 20.11 Protocol Amendments

Any significant change in the study protocol will require an amendment. The investigator and the Medical Monitor indicate their approval by signing the approval page of the amendment. Once the Sponsor has approved a protocol amendment, the investigator must submit it to the IRB for written approval. The approval letter, signed by the IRB chair, must refer specifically to the investigator, the Sponsor protocol number, the protocol title, the protocol amendment number, and the date of the protocol amendment. The Sponsor submits a copy of the protocol amendment to the appropriate regulatory agency/agencies. A protocol amendment may be implemented after it has been approved by the IRB. Where applicable, the amendment must receive a favorable opinion from the regulatory agency.

A protocol change intended to eliminate an apparent immediate hazard to subjects may be implemented immediately, but the change must then be documented in an amendment, and reported to the IRB/IEC within 5 working days. When appropriate, the Sponsor will prepare a protocol amendment and submit it to the appropriate regulatory agency in the required time frame.

#### 20.12 Change in Investigator

If any investigator retires, relocates, or otherwise withdraws from conducting a study, the responsibility for maintaining records may be transferred to the Sponsor, IRB/IEC, or other investigator. The Sponsor must be notified of and agree to the change. Regulatory agencies will be notified with the appropriate documentation. An updated Investigator Agreement Form will be filed with the Sponsor for any changes in the study personnel reported in the current form.

#### 20.13 Confidentiality

All unpublished information that the Sponsor gives to the investigator shall be kept confidential and shall not be published or disclosed to a third party without the prior written consent of the Sponsor.

When the Sponsor generates reports for presentations to regulatory agencies, one or more of the investigators who have contributed significantly to the study will be asked to endorse the final report. The endorsement is required by some regulatory agencies.

The investigator shall not make a patent application based on the results of this study and shall not assist any third party in making such an application without the written authorization of the Sponsor unless otherwise specified in the CTA.

#### 20.14 Disclosure Statement

##### Restricted Distribution of Documents

This document contains information that is confidential and proprietary to the Sponsor. This information is being provided to you solely for the purpose of evaluating and/or conducting a clinical trial for the Sponsor. You may disclose the contents of this document only to study personnel under your supervision, IRBs or duly authorized representatives of regulatory agencies for this purpose under the condition that they maintain confidentiality. The contents of this document may not be used in any other clinical trial, disclosed to any other person or entity, and/or published without the prior written permission of the Sponsor. The foregoing shall not apply to disclosure required by any regulations; however, you will give prompt notice to the Sponsor of any such disclosure.

Any information that may be added to this document also is confidential and proprietary to the Sponsor and must be kept in confidence in the same manner as the contents of this document.

## 20.15 Records Retention

The investigator shall retain and preserve one copy of all data generated in the course of the study, specifically including but not limited to those documents defined by GCP as essential documents, for the longer of: (i) 2 years after the last marketing authorization for the study device has been approved or the Sponsor has discontinued its research with respect to such investigational device or (ii) such longer period as required by applicable global regulatory requirements. At the end of such period, the investigator shall notify in writing the Sponsor of its intent to destroy all such material. The Sponsor shall have 30 days to respond to the investigator's notice, and the Sponsor shall have a further opportunity to retain such materials at the Sponsor's expense.

### 20.15.1 Sample Retention

Blood, serum, tissue or other samples collected from subjects may be stored for up to 5 years after the end of the study and will be destroyed after that time. In addition, samples can be destroyed at the request of the subject at any time. Data obtained from samples prior to sample destruction will remain the property of the Sponsor.

## 20.16 Publications

On completion of the study, the investigator may publish the results in recognized (refereed) scientific journals if the data warrant publication, subject to the provisions of the Clinical Trial Agreement. Unless otherwise specified in the Clinical Trial Agreement, the following process shall occur:

The institution and principal investigator shall not publish or present data from an individual study center until the complete multi-center study has been presented in full or for 2 years after the termination of the multi-center study, whichever occurs first. Subsequent publications must refer to the multi-center findings. Thereafter, if the principal investigator expects to participate in the publication of data generated from this site, the institution and principal investigator shall submit reports, abstracts, manuscripts and/or other presentation materials to the Sponsor for review prior to submission for publication or presentation. The Sponsor shall have 60 days to respond with any requested revisions, including without limitation, the deletion of confidential information. The principal investigator shall act in good faith upon requested revisions, except the principal investigator shall delete any confidential information from such proposed publication. The principal investigator shall delay submission of such publication or presentation materials for up to an additional 90 days in order to have a patent application(s) filed.

## 20.17 Subject Injury

In general, if a subject is injured as a direct result of the study drug, the Sponsor will pay for reasonable and necessary medical treatment for the injury, to the extent the expenses are not covered by the subject's medical insurance, a government program, or other responsible third party. If laws or regulations of the locality in which the trial is taking place require additional payment of expenses, the Sponsor shall comply with such law or regulation. Where applicable, the Sponsor has taken specific national insurance.

## 21 References

- Agresti, A. (1990). *Categorical Data Analysis*. New York, John Wiley & Sons.
- Amarex, LLC. Interim Analysis and DSMB Preparation Standard Operating Procedure (SOP BM007 v9, March 1, 2012), Amarex LLC, Germantown, MD
- Angus, D. C., W. T. Linde-Zwirble, et al. (2001). "Epidemiology of severe sepsis in the United States: analysis of incidence, outcome, and associated costs of care." *Crit Care Med* **29**(7): 1303-10.
- Beutler, B. and E. T. Rietschel (2003). "Innate immune sensing and its roots: the story of endotoxin." *Nat Rev Immunol* **3**(2): 169-76.
- Chen JYH, Demets DL, and Lan KKG. (2004). "Increasing the sample size when unblinded interim results is promising." *Stat Med* **23**(7): 1023- 1038.
- Cruz, D., M. Antonelli, et al. (2009). "Early use of polymyxin-B hemoperfusion in abdominal septic shock." *EUPHAS*.
- Cruz, D. N., M. A. Perazella, et al. (2007). "Effectiveness of polymyxin B-immobilized fiber column in sepsis: a systematic review." *Crit Care* **11**(2): R47.
- Dellinger, R. P., J. M. Carlet, et al. (2004). "Surviving Sepsis Campaign guidelines for management of severe sepsis and septic shock." *Crit Care Med* **32**(3): 858-73.
- Dellinger, R. P., M. M. Levy, et al. (2008). "Surviving Sepsis Campaign: international guidelines for management of severe sepsis and septic shock: 2008." *Crit Care Med* **36**(1): 296-327.
- Dellinger, R.P, M. M. Levy, et al. (2013). "Surviving Sepsis Campaign: International Guidelines for Management of Severe Sepsis and Septic Shock: 2012" *Crit Care Med* **41**(2): 580-637.
- Dellinger, R. P. and J. L. Vincent (2005). "The Surviving Sepsis Campaign sepsis change bundles and clinical practice." *Crit Care* **9**(6): 653-4.
- Dinna N. Cruz, M. A., et al. (2009). "Early Use of Polymyxin B Hemoperfusion in Abdominal Septic Shock." *JAMA* **301**(23): 8.
- Fiore, B., M. Soncini, et al. (2006). "Multi-scale analysis of the toraymyxin adsorption cartridge. Part II: computational fluid-dynamic study." *Int J Artif Organs* **29**(2): 251-60.
- Girard, T. D., S. M. Opal, et al. (2005). "Insights into severe sepsis in older patients: from epidemiology to evidence-based management." *Clin Infect Dis* **40**(5): 719-27.
- Hotchkiss, R. S. and I. E. Karl (2003). "The pathophysiology and treatment of sepsis." *N Engl J Med* **348**(2): 138-50.
- Inc., S. I. (1990). *SAS/STAT User's Guide version 6, 4th ed.* Cary, NC.
- Kalbfleisch, J., Prentice, RL. (1980). *The Statistical Analysis of Failure Time Data*. New York, John Wiley.
- Levy, M. M., M. P. Fink, et al. (2003). "2001 SCCM/ESICM/ACCP/ATS/SIS International Sepsis Definitions Conference." *Crit Care Med* **31**(4): 1250-6.
- Little, R., Milliken, GA, et al. (1996). *SAS System for Mixed Models*. Cary, NC, SAS Institute Inc.
- Marshall, J. C., D. Foster, et al. (2004). "Diagnostic and prognostic implications of endotoxemia in critical illness: results of the MEDIC study." *J Infect Dis* **190**(3): 527-34.
- Milliken, G., Johnson, DE (1992). *Analysis of Messy Data*. New York, Chapman & Hall/CRC.

- O'Brien, P.C., Fleming, T.R. (1979). "A multiple testing procedure for clinical trials." Biometrics **35**: 549-556.
- Opal, S. M. and A. S. Cross (1999). "Clinical trials for severe sepsis. Past failures, and future hopes." Infect Dis Clin North Am **13**(2): 285-97, vii.
- Proschan, M., Liu, Q., Hunsberger, S. (2003). "Practical midcourse sample size modification in clinical trials." Control Clin Trials **24**(1): 4-15.
- Shoji, H. (2003). "Extracorporeal endotoxin removal for the treatment of sepsis: endotoxin adsorption cartridge (Toraymyxin)." Ther Apher Dial **7**(1): 108-14.
- Trzeciak, S., J. V. McCoy, et al. (2008). "Early increases in microcirculatory perfusion during protocol-directed resuscitation are associated with reduced multi-organ failure at 24 h in patients with sepsis." Intensive Care Med **34**(12): 2210-7.
- Vesentini, S., M. Soncini, et al. (2006). "Multi-scale analysis of the toraymyxin adsorption cartridge. Part I: molecular interaction of polymyxin B with endotoxins." Int J Artif Organs **29**(2): 239-50. <sup>i</sup>

## **22 Appendices**

Appendix 1 – Infection definitions for EUPHRATES

Appendix 2 - APACHE II score tool

Appendix 3 - MOD score tool

Appendix 4 - Package Insert for Toraymyxin PMX-20R

Appendix 5 - 2012 Surviving Sepsis Campaign Guidelines

Appendix 6 – Instruction in the event of a PMX Cartridge Malfunction or Defect

## Appendix 1, Infection Definitions for EUPHRATES protocol

**Infection Definitions for EUPHRATES protocol**

The following is a set of definitions for infection, listed by infection *site*, from the following source: The International Sepsis Forum Consensus Conference on Definitions of Infection in the Intensive Care Unit. Critical Care Medicine, 2005 Vol 33, No. 7. The six most frequent causes of infections in septic patients are defined herein and all others will be classified as "other."

Note: superficial swab cultures are not acceptable for including in the definition of infection for this study

**1. Pneumonia***a) Microbiologically confirmed:*

The patient must have a new or progressive radiographic infiltrate, along with a high clinical suspicion of pneumonia (using a Gram stain of a lower respiratory tract sample) plus a definite cause established by the recovery of a probable etiologic agent from:

- a) an uncontaminated specimen (blood, pleural fluid, transtracheal aspirate, or transthoracic aspirate);
- b) the recovery from respiratory secretions of a likely pathogen that does not colonize the upper airways (e.g., *Mycobacterium tuberculosis*, *Legionella* species, influenza virus, or *Pneumocystis jiroveci* (*carinii*));
- c) recovery of a likely/possible respiratory pathogen in high concentrations using quantitative cultures of a lower respiratory tract sample (endotracheal aspirate, BAL, or protected specimen brush); or
- d) positive serology

*b) Probable:*

The patient must have a new or progressive radiographic infiltrate along with a high clinical suspicion of pneumonia (using a Gram stain of a lower respiratory tract sample) plus detection (by staining or culture) of a likely pulmonary pathogen in respiratory secretions (expectorated sputum, endotracheal or bronchoscopic aspirate, or quantitatively cultured bronchoscopic BAL fluid or brush catheter specimen), but in concentrations below the diagnostic threshold, or the presence of a negative lower respiratory tract culture if collected within 72 hrs after starting a new antibiotic regimen.

*c) Possible:*

Abnormal chest radiograph of uncertain cause, in a patient with a low or moderate clinical suspicion of pneumonia, but with microbiological or serological evidence of definite or probable pneumonia (as defined above).

**2. Bloodstream infection (BSI)***a) Patient must meet the following two criteria:*

- Patient has a recognized pathogen (defined as a microorganism not usually regarded as a common skin contaminant, i.e., diphtheroids, *Bacillus* species, *Propionibacterium* species, coagulase-negative staphylococci, or micrococci) cultured from one or more blood cultures  
**or**
- A common skin contaminant (e.g., diphtheroids, *Bacillus* species, *Propionibacterium* species, coagulase-negative staphylococci, or micrococci) cultured from two or more blood cultures drawn on separate occasions (including one drawn by venipuncture) **and**  
The organism cultured from blood is not related to an infection at another site, including intravascular-access devices

*b) Secondary bloodstream infection (BSI) (other than catheter-related BSI)*

Patient must meet the following two criteria:

- Patient has a recognized pathogen defined as a microorganism different from a common skin contaminant (i.e., diphtheroids, *Bacillus* species, *Propionibacterium* species, coagulase-negative staphylococci, or micrococci) cultured from one or more blood cultures
- The organism cultured from blood is related to an infection with the same organism at another site

### 3. Intravascular Catheter-related sepsis

Definite catheter-related sepsis with bacteriologic confirmation is defined as at least one peripheral positive blood culture and one of the following:

- A positive semiquantitative (>15 colony-forming units [cfu]/catheter segment) or quantitative ( $\geq 10^3$  cfu/catheter segment) catheter tip culture (i.e., catheter colonization), whereby the same microorganism (species and antibiogram) is isolated from the catheter segment and peripheral blood
- A positive hub or exit site culture growing the same microorganism as peripheral blood **or**
- Positive paired central and peripheral blood cultures growing the same organism, where the central blood culture is positive  $\geq 2$  hrs earlier than the peripheral blood culture or has five times the growth of the peripheral blood culture

### 4. Intra-abdominal

#### a) Primary peritonitis

Primary peritonitis (also referred to as spontaneous bacterial peritonitis) is defined as a microbial infection of the peritoneal fluid in the absence of a gastrointestinal perforation, abscess, or other localized infection within the gastrointestinal tract

##### i) *Microbiologically confirmed:*

the presence of a clinically compatible presentation of primary peritonitis with the isolation of microbial pathogens (in peritoneal fluid or blood) along with evidence of acute inflammatory reaction within the peritoneal fluid (i.e., >500 leukocytes/mL) with a neutrophilic predominance, an ascitic fluid pH of <7.35 (arterial to ascitic pH difference of >0.1), or a lactate concentration of >2.5 mg/L

##### ii) *Probable:*

Clinically appropriate setting with evidence of an inflammatory ascitic fluid (>500 leukocytes/mL with a neutrophil predominance) in the presence of a positive Gram stain but negative peritoneal fluid cultures or in the presence of a positive blood culture for a pathologic organism with inflammatory cells in ascitic fluid

##### iii) *Possible:*

A compatible clinical illness with an inflammatory peritoneal fluid (>500 leukocytes/mL) in the absence of a positive culture (in peritoneal fluid or blood) or Gram stain

#### b) Secondary peritonitis

Secondary peritonitis is a microbial infection of the peritoneal space following perforation, abscess formation, ischemic necrosis, or penetrating injury of the intra-abdominal contents

##### i) *Microbiologically confirmed:*

Isolation of one or more microbial pathogens found in the peritoneum or the blood >24 hrs after a gastrointestinal perforation of the stomach, esophagus or duodenum, or any perforation of the small bowel distal to the ligament of Treitz. Spillage of luminal contents during an operative procedure is not sufficient evidence of perforation that allows for definitive diagnosis of peritonitis. Furthermore, a penetrating abdominal wound or documented perforation that is



surgically repaired within 12 hrs of its occurrence is not sufficient evidence to support diagnosis of secondary bacterial peritonitis.

*ii) Probable:*

Compatible clinical illness associated with documented evidence of perforation (free air in the abdomen on radiographic studies or surgical confirmation of peritoneal inflammation following luminal perforation in the absence of microbiologically confirmed peritonitis). A Gram stain in the absence of a positive culture from the peritoneum would be considered probable secondary bacterial peritonitis.

*iii) Possible:*

Upper gastrointestinal perforation or penetrating abdominal trauma that is surgically repaired without further evidence of microbiologic confirmation or clinical signs or symptoms supportive of a diagnosis of bacterial or fungal peritonitis. A finding of an inflammatory peritoneal fluid in the presence of a documented but localized intra-abdominal abscess in the absence of culture confirmation would also be considered possible secondary bacterial peritonitis.

c) Tertiary peritonitis

Tertiary peritonitis is defined as persistent intra-abdominal inflammation and clinical signs of peritoneal irritation following secondary peritonitis from nosocomial pathogens.

*i) Microbiologically confirmed:*

Isolation of one or more nosocomial pathogens from peritoneal fluid or blood in an appropriate clinical situation (>48 hrs after treatment for primary or secondary peritonitis).

*ii) Probable:*

Compatible clinical illness with documented secondary peritonitis with persistent peritoneal inflammation (>500 leukocytes/mL peritoneal fluid) in the absence of microbiologically confirmed microbial persistence in the peritoneal space.

*iii) Possible:*

Compatible clinical illness with persistent signs of systemic inflammation but without clear documented evidence of persistent inflammation within the peritoneal space following secondary bacterial peritonitis.

d) Intra-abdominal abscess

*i) Microbiologically confirmed:*

Clinical, radiographic, and direct surgical confirmation of an inflammatory collection within the peritoneal space or surrounding structures with isolation of one or multiple microbial pathogens from the fluid collection. Microbiologic confirmation will require specimen collection from percutaneous aspirations under sterile technique or direct surgical observation with acquisition of culture material directly from the abscess cavity or the blood.

*ii) Probable:*

The presence of an abnormal collection of fluid in the intra-abdominal contents or surrounding structures with evidence of inflammatory cells and/or positive Gram stain but with negative cultures from that fluid accumulation or blood.

*iii) Possible:*

Clinical or radiographic evidence of an abnormal fluid accumulation within the abdominal contents or surrounding structures but without microbiologic or surgical confirmation.

e) Biliary tract infection

*i) Microbiologically confirmed:*

the An acute inflammatory process of the biliary tract or surrounding structures with the isolation of pathogenic microorganisms obtained via percutaneous or direct surgical collection of samples in lumen of the gall bladder or the biliary tract or the blood.

*ii) Probable:*

An appropriate clinical syndrome with evidence of microbial infection verified by Gram stain from the biliary system but with negative cultures from the biliary system or blood for enteric microbial pathogens.

*iii) Possible:*

This includes patients with clinical evidence of biliary tract infection with surgical or radiographic evidence of suppurative complications but in the absence of microbiologic verification, positive blood cultures, or a Gram stain evidence of active infection. In the presence of ascending cholangitis, a positive blood culture is sufficient to make the diagnosis of microbiologically confirmed, ascending cholangitis (>50% of patients will be bacteremic with this biliary tract infection). A positive culture from the biliary tract in the absence of clinical symptoms (bactobilia) is not sufficient to make a diagnosis. Positive culture from a T-tube drainage from the common bile duct is not sufficient evidence to make a diagnosis of biliary tract infection if the tube has been in place for >24 hrs.

f) Pancreatic infection

*i) Microbiologically confirmed:*

from This requires direct confirmation of positive microbial cultures from the pancreas or surrounding structures by percutaneous aspiration or direct visualization and culture at the time of surgery or the bloodstream.

*ii) Probable:*

The presence of surgical or radiographic evidence of an abnormal collection of an inflammatory focus within the substance of the pancreas or surrounding structures with a positive Gram stain from the pancreatic collection in the absence of culture documentation.

*iii) Possible:*

Radiographic or direct surgical inspection with evidence suggestive of pancreatic abscess or other type of infection.

5. Urosepsis in catheterized patients (urinary catheter is present or has been removed within the past 6 days)

a) Lower urinary tract infection

The presence of suggestive signs and symptoms including fever (>38°C), urgency, frequency, dysuria, pyuria, hematuria, positive Gram stain, pus, suggestive imaging **and** Positive dipstick for leukocyte esterase and/or nitrate **or** pyuria ( $\geq 10$  white blood cells/ $\mu\text{L}$  or  $\geq 3$  white blood cells/high-power field of unspun urine)

**or** organisms seen on Gram stain of unspun urine **or** frank pus expressed around the urinary catheter **or**  $>10^3$  cfu/mL

b) Upper urinary tract infection (kidney, ureter, bladder, urethra, or tissue surrounding the retroperitoneal or perinephric space) Must meet **one** of the following criteria:

Organism isolated from culture of fluid (other than urine) or tissue from the affected site; an abscess or other evidence of infection seen on direct examination, during surgery, or by histopathologic examination

or two of the following:

Fever (>38°C), urgency, localized pain or tenderness at involved site, and any of the following: purulent drainage from the affected site, pyuria, hematuria, organism isolated from culture, positive Gram

stain, radiographic evidence of infection (e.g., ultrasound, computed tomography, magnetic resonance imaging, radiolabeled scan)

**6. Skin and soft tissue infections**

a) *Surgical site infection* is defined as an infection that arises within 30 days of an operative procedure and at the site of surgical intervention. Symptoms and signs suggestive of a surgical site infection include wound erythema and blanching, tenderness, pain, purulent discharge, fever (temperature >38.0°C), and leukocytosis. A superficial surgical site infection involves the skin or subcutaneous tissues alone, whereas a deep surgical site infection involves the fascia or muscle layers, and an organ space surgical site infection involves the deeper anatomic areas opened during the surgical procedure.

b) Nonsurgical site infections

*Cellulitis* is defined as an acute spreading infection of the skin and underlying soft tissue suggested by the presence of a rapidly expanding erythema, local tenderness, pain, swelling, lymphangitis, and lymphadenopathy, which is frequently accompanied by systemic signs and symptoms including malaise, fever (temperature >38.0°C), and chills.

*Necrotizing cellulitis and fasciitis* are defined as acute, rapidly progressing, and life-threatening destructive (i.e., necrotizing) infections of the subcutaneous tissues dissecting along tissue planes. Although these two clinical entities exhibit some distinctive clinical and microbial characteristics, they share common features. The symptoms and signs suggestive of necrotizing cellulitis or fasciitis are intense local pain (a cardinal feature), exquisite tenderness, erythema (initially discrete but evolving to red-purple and then blue-gray cutaneous lesions often with hemorrhagic bullae), swelling, edema, crepitations (in the case of necrotizing cellulitis), and extensive tissue necrosis, which are associated with prominent systemic toxicity (toxic shock syndrome, severe sepsis, or septic shock)

Appendix 2, APACHE II

<b>APACHE II SCORE CALCULATION WORKSHEET</b>					
<i>Instructions: Please complete sections as indicated. Points are determined from the worst physiologic variables in the first 24 hours.</i>					
<b>CALCULATION MODULE</b>					
<b>1. Temperature (°C/F)</b>	<b>Points</b>	<b>6. Arterial pH</b>	<b>Points</b>	<b>11. White Blood Count (per mm<sup>3</sup>)</b>	<b>Points</b>
>41°C / ≥ 105.8F	4 <input type="checkbox"/>	≥ 7.70	4 <input type="checkbox"/>	≥ 40	4 <input type="checkbox"/>
39-40.9 / 102.1-105.7	3 <input type="checkbox"/>	7.60-7.69	3 <input type="checkbox"/>	20-39.9	2 <input type="checkbox"/>
38.5-38.9 / 101.3-102	1 <input type="checkbox"/>	7.50-7.59	1 <input type="checkbox"/>	15-19.9	1 <input type="checkbox"/>
36-38.4 / 96.8-101.2	0 <input type="checkbox"/>	7.33-7.49	0 <input type="checkbox"/>	3-14.9	0 <input type="checkbox"/>
34-35.9 / 93.1-96.7	1 <input type="checkbox"/>	7.25-7.32	2 <input type="checkbox"/>	1-2.9	2 <input type="checkbox"/>
32-33.9 / 89.5-93	2 <input type="checkbox"/>	7.15-7.24	3 <input type="checkbox"/>	< 1	4 <input type="checkbox"/>
30-31.9 / 85.9-89.4	3 <input type="checkbox"/>	<7.15	4 <input type="checkbox"/>	<b>12. Glasgow Coma Scale (GCS)</b>	
≤ 29.9 / ≥ 85.8	4 <input type="checkbox"/>	<b>7. Serum Sodium (mmol/L)</b>		<b>Eyes Opening</b>	
<b>2. MAP = [(2 * DBP + SBP) / 3] (mmHg)</b>		≥ 180		Spontaneous	
≥ 160	4 <input type="checkbox"/>	160-179		To voice	
130-159	3 <input type="checkbox"/>	155-159		To pain	
110-129	2 <input type="checkbox"/>	150-154		Absent	
70-109	0 <input type="checkbox"/>	130-149		<b>Verbal Response</b>	
50-69	2 <input type="checkbox"/>	120-129		Converses/Oriented	
≤ 49	4 <input type="checkbox"/>	111-119		Converses/Disoriented	
<b>3. Heart Rate (beats per min)</b>		≤ 110		Inappropriate	
≥ 180	4 <input type="checkbox"/>	<b>8. Serum Potassium (mmol/L)</b>		Incomprehensible	
140-179	3 <input type="checkbox"/>	≥ 7		Absent	
110-139	2 <input type="checkbox"/>	6-6.9		<b>Motor Response</b>	
70-109	0 <input type="checkbox"/>	5.5-5.9		Obeys Commands	
55-69	2 <input type="checkbox"/>	3.5-5.4		Localizes pain	
40-54	3 <input type="checkbox"/>	3-3.4		Withdraws from pain	
≤ 39	4 <input type="checkbox"/>	2.5-2.9		Decorticate (flexion) rigidity	
<b>4. Respiratory Rate (breaths per min)</b>		< 2.5		Decerebrate (extension) rigidity	
≥ 50	4 <input type="checkbox"/>	<b>9. Serum Creatinine (mg/dL)</b>		Absent	
35-49	3 <input type="checkbox"/>	≥ 3.5 & acute renal failure		<b>GCS Score =</b>	
25-34	1 <input type="checkbox"/>	2.0-3.4 & acute renal failure		<b>GCS Points = 15 – GCS Score =</b>	
12-24	0 <input type="checkbox"/>	1.5-1.9 & acute renal failure		<b>APS Points (Sum of 12 points above) =</b>	
10-11	1 <input type="checkbox"/>	≥ 3.5 & chronic renal failure		<b>Age Points</b>	
6-9	2 <input type="checkbox"/>	2.0-3.4 & chronic renal failure		≥ 75	
≤ 5	4 <input type="checkbox"/>	1.5-1.9 & chronic renal failure		65-74	
<b>5. Oxygenation</b>		0.6-1.4		55-64	
a. A-a gradient if FiO <sub>2</sub> ≥ 0.5		< 0.6		45-54	
≥ 500	4 <input type="checkbox"/>	<b>10. Hematocrit (%)</b>		≤ 44	
350-499	3 <input type="checkbox"/>	≥ 60		<b>Chronic Health Points *</b>	
200-349	2 <input type="checkbox"/>	50-59.9		Yes, Non-operative	
< 200	0 <input type="checkbox"/>	46-49.9		Yes, Emergency post-operative	
b. PaO <sub>2</sub> if FiO <sub>2</sub> < 0.5		30-45.9		Yes, Elective post-operative	
> 70	0 <input type="checkbox"/>	20-29.9		No	
61-70	1 <input type="checkbox"/>	<20		<b>APACHE II Score =</b>	
55-60	3 <input type="checkbox"/>			APS Points + Age Points +	
<55	4 <input type="checkbox"/>			Chronic Health Points	

**FOOTNOTES**

**\* Chronic Health:**  
 Organ insufficiency or immunocompromised state must have been evident prior to this hospital admission and conform to the following criteria:  
**LIVER:** Biopsy-provencirrhosis and documented portal hypertension; episodes of past upper GI bleeding attributed to portal hypertension; or prior episodes of hepatic failure/encephalopathy/coma.  
**CARDIOVASCULAR:** New York Heart Association Class IV  
**RESPIRATORY:** Chronicrestrictive, obstructive, or vascular disease resulting in severe exercise restriction; i.e. unable to climb stairs or perform household duties, or documented chronic hypoxia, hypercapnia, secondary polycythemia, severe pulmonary hypertension (>40 mmHg), or respiratory dependency.  
**RENAL:** Receiving chronic dialysis.  
**IMMUNOCOMPROMISED:** Patient has received therapy that suppresses resistance to infection; e.g. immunosuppression, chemotherapy, radiation, long-term or recent high-dose steroids, or has disease that is sufficiently advanced to suppress resistance to infection: e.g. leukemia, lymphoma, AIDS.

## Appendix 3, MOD Score

<b>MOD SCORE CALCULATION WORKSHEET</b>
--

*Instructions: Please complete sections as indicated. Add the scores for the worst value in each organ system over 24 hours.*

<b>CALCULATION MODULE</b>
---------------------------

Variable		0	1	2	3	4	Raw Data
<b>Respiratory (PO<sub>2</sub>/FiO<sub>2</sub>)</b>		> 300	226 – 300	151 – 225	76 – 150	≤ 75	
<b>Renal (Creatinine)</b>	Conventional Units ----->	≤ 1.13	1.14-2.26	2.27-3.96	3.97-5.65	> 5.66	
	SI Units ----->	≤ 100	101 – 200	201 – 350	351 – 500	> 500	
<b>Hepatic (Total Bilirubin)</b>	Conventional Units ----->	< 1.2	1.2-3.5	3.6-7.0	7.1-14.0	> 14.0	
	SI Units ----->	≤ 20	21 – 60	61 – 120	121-240	> 240	
<b>CNS (Glasgow Coma Score)</b>		15	13 – 14	10 – 12	6 – 9	< 6	
<b>CVS (R/P Ratio) Heart Rate X RAP / MAP</b>		≤ 10.0	10.1 – 15	15.1 – 20	20.1 – 30	> 30	
<b>Hematologic (Platelets) x 10<sup>3</sup></b>		> 120	81 – 120	51 – 80	21 – 50	≤ 20	

**FOOTNOTES**

- a. The  $PO_2/FiO_2$  ratio is calculated without reference to the use or mode of mechanical ventilation, and without reference to the use or level of PEEP
- b. The serum creatinine level is measured in  $\mu\text{mol/liter}$ , without reference to the use of dialysis.
- c. The serum bilirubin level is measured in  $\mu\text{mol/liter}$ .
- d. The pressure-adjusted heart rate is calculated as the product of the heart and right atrial (central venous) pressure, divided by the mean arterial pressure:

$$\text{Pressure Adjusted Heart Rate} = \frac{\text{Heart Rate} \times \text{RAP}}{\text{Mean BP}}$$

- e. The platelet count is measured in platelets/mL  $\times 10^3$ .
- f. The Glasgow Coma score is preferably calculated by the patient's nurse, and is scored conservatively (for the patient receiving sedation or muscle relaxants, normal function is assumed unless there is evidence of intrinsically altered mentation).

Appendix 4, Package Insert for Toraymyxin PMX-20R



# TORAYMYXIN PMX-20R

## EXTRACORPOREAL HEMOPERFUSION CARTRIDGE

### INSTRUCTIONS FOR USE

#### Table of Contents

Device Description .....	2
Indications for Use .....	2
Contraindications .....	2
Adverse Reactions .....	2
Potential Adverse Events.....	2
Adverse Reactions of Polymyxin B .....	3
Warnings and Precautions .....	3
Warnings .....	3
Precautions.....	3
General precautions .....	3
Precautions relating to heparin administration.....	4
Precautions for storage and handling .....	4
Precautions before initiating PMX treatment.....	4
Precautions during PMX treatment .....	4
Precautions at the end of PMX treatment .....	4
Use of the PMX Cartridge .....	5
Rinsing and Priming Procedure .....	5
Rinsing the blood tubing.....	5
Priming the cartridge and blood lines.....	6
Operating Procedure .....	6
Finishing Procedure .....	6
Normal condition .....	6
Abnormal condition.....	6
Disposing of the Cartridge .....	6
Explanation of symbols used on the device labelling .....	7
References.....	7
Warranty Limitations .....	7



# TORAYMYXIN PMX-20R

## Extracorporeal Hemoperfusion Cartridge

- Sterile •Single Use only •Do not re-use •Sterilized by steam
- Do not use if the packaging is damaged or open
- Do not use if the sterilization indicator is whitish yellow

Read Instructions For Use carefully before use.

### DEVICE DESCRIPTION

TORAYMYXIN PMX-20R (PMX) is an extracorporeal hemoperfusion cartridge intended for the selective removal of endotoxin from circulating blood through direct hemoperfusion (DHP).

The PMX cartridge (cartridge) contains fibers made of polystyrene derivatives (alphachloro-aceto-amido-methylated polystyrene). Polymyxin B is immobilized on the surface of these fibers (see Figure 1). This fixed Polymyxin B adsorbs and removes endotoxin from the patient's circulating blood.

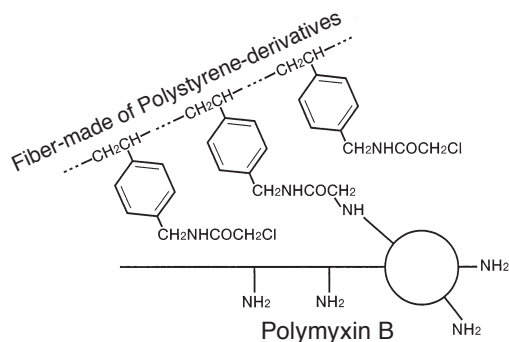

Figure 1: Polymyxin B immobilized fibers (schematic model)

Each cartridge contains 56±3g fibers (dry weight) and has a blood volume capacity of 135±5 mL. The dimensions and structure of the cartridge are as follows:

- Length: 225 mm
- Diameter (max): 63 mm
- Housing diameter: 49 mm
- Connection between the cartridge and blood tubing: Luer-lock type connectors

The following additional equipment is needed to carry out treatment with PMX:

- A blood pump for extracorporeal circulation at a blood flow rate of 20 – 200 mL/min, monitors for inlet (Pi) and outlet (Po) pressures and an infusion pump for the administration of anticoagulants,
- Hemoperfusion blood tubing suitable for use with the hemoperfusion pump,
- For extracorporeal circulation by veno-venous access, insert a 12F or 14F double lumen catheter into the femoral vein or the subclavian vein.

### INDICATIONS FOR USE

PMX is indicated for use in the treatment of patients with sepsis or septic shock caused by gram-negative bacteria, who meet the following conditions:

- Endotoxemia or suspected gram-negative infection, and
- Systemic Inflammatory Response Syndrome (SIRS), as defined by the presence of at least two of the following four conditions:
  - Fever or hypothermia (body temperature of above 38°C or below 36°C)
  - Tachycardia (heart rate of above 90 bpm)
  - Tachypnea [(respiratory rate of above 20 breaths/min, or PaCO<sub>2</sub> below 4.3 kPa (32mmHg)]
  - White blood cell count of above 12,000 cells/mm<sup>3</sup>, below 4,000 cells/mm<sup>3</sup> or above 10% immature (band) forms.

### CONTRAINDICATIONS

Treatment with PMX is contraindicated in the following patients:

- Patients in whom the use of heparin would cause a tendency to uncontrolled bleeding or for whom adequate anticoagulant therapy cannot be safely achieved, such as patients with hemophilia, or
- Patients with known hypersensitivity to heparin, Polymyxin B or chemicals associated with DHP.

### ADVERSE REACTIONS

#### Potential Adverse Events

The adverse events below may occur at any time during PMX treatment.

Table 1 lists the adverse events.

Table 1. Adverse Events

Type of Adverse Events
Thrombocytopenia, Decreased blood pressure, Allergy (Erythema, etc.), Shock (Decreased blood pressure, Dyspnea, Tachycardia, Hypothermia, Chest pain, Vomiting, Cyanosis, etc), Anaphylactic shock, Ventricular tachycardia, Ventricular fibrillation, Hypoxemia, Cardio palmus, Air embolism, Infection of entry site, Bleeding at puncture site, Abnormal bleeding (due to heparin), Tachycardia, Increased pressure at the entrance of the blood purifier [This is attributable to the dosage and administration of anticoagulants and pathological conditions in patients.], Blood clotting in PMX [Blood clotting is attributable to the dosage and administration of anticoagulants and pathological conditions in patients.]

Patients with septic shock usually have severe underlying diseases, including, but not limited to cancer, trauma, and cardiovascular disease. These underlying diseases, deterioration in the patient's state of health and/or death due to the progression of sepsis may be reported as adverse events during or after PMX-DHP.

## Adverse Reactions of Polymyxin B

### Drug to drug interactions and adverse drug reactions of Polymyxin B

The following drug to drug interactions and adverse drug reactions after oral or local administration of Polymyxin B, immobilized in PMX, are mentioned in the precaution of Instruction for Use of each drugs.

#### 1. Drug to drug interactions

When Polymyxin B is administered concomitantly with anesthetics, muscle relaxants or aminoglycoside antibiotics, respiratory depression due to a curare-like stabilization effect (neuromuscular blocking action) may occur as a result of drug to drug interactions. Medical personnel must pay sufficient attention to their concomitant use.

#### 2. Adverse drug reactions

Serious adverse drug reactions: Shock, Deafness, Respiratory depression due to neuromuscular blocking action.

Other adverse drug reactions: Renal disorder, Paresthesia, Dizziness, Headache, Pyrexia, Lethargy, Ataxia, Visual disturbance, Rash, Pruritus, Nausea, Vomiting, Anorexia, Diarrhea, Formication, Numbness of tongue, Numbness of lips.

## WARNINGS AND PRECAUTIONS



### Warnings

1. The PMX cartridge is a disposable medical device intended for single use only. Do not reuse the cartridge. Reuse of the PMX cartridge might cause following adverse events and malfunctions, such as, infection caused by microbiological contamination, adverse reactions caused by residual reprocessing agents and/or residual blood components and performance changes caused by deterioration of device components.
2. The PMX cartridge is designed for use in DHP. Do not use in a plasmapheresis procedure.
3. Ensure that the blood flows in the direction as indicated by the arrow on the label of the cartridge.
4. The PMX cartridge is designed for treatment using unfractionated heparin as an anticoagulant. The safety and efficacy of PMX treatment using other anticoagulants including, but not limited to, low molecular weight heparin (LMWH) or citrate preparations, have not been established. The anticoagulant is required to prevent thrombus formation within the extracorporeal circuit. Anticoagulation with too much heparin is associated with an increased risk of bleeding, especially after a surgical operation.
5. It is essential to rinse and then prime the blood tubing and the cartridge with appropriate solutions (see Rinsing and Priming Procedure) in order to rinse out the acidic solution in the cartridge and to restore the physiological conditions.
6. The inlet pressure of the cartridge must be below 33 kPa (250 mmHg). The maximum tolerable pressure of the cartridge is 66 kPa (500 mmHg). If an unusual pressure difference (approx. 26.4 kPa (200 mmHg)) is observed between the inlet and outlet of the cartridge, clotting in the cartridge must be suspected.
7. If the tubing is equipped with an air bubble detector, connect the outlet tubing to it. This will minimize the risk of air embolism.

## Precautions

### General Precautions

1. At all times during PMX treatment, medical personnel must monitor the patient for the symptoms of adverse events, in particular for decreased blood pressure, thrombocytopenia and allergy. It is recommended to monitor blood pressure during PMX-DHP and to measure platelet counts before and after PMX-DHP.
2. If treatment with three cartridges per cycle is not effective, other treatment should be applied.
3. PMX should be used in patients with endotoxemia or suspected gram-negative infection, after the outcome of treatment, including antibiotic therapy, is confirmed sufficiently.
4. PMX must be carefully used in patients treated with anesthetics, muscle relaxants or aminoglycoside antibiotics, since respiratory depression due to a curare-like stabilization effect (neuromuscular blocking action) may occur as a result of drug to drug interactions.
5. Medical personnel must pay sufficient attention to a decrease in the patient's body temperature. The extracorporeal circuit and patient should be adequately warmed if necessary.
6. Medical personnel must pay special attention to the treatment of patients whose renal function is impaired. A small possibility exists that a very small amount of Polymyxin B (less than 1 ppb) remaining in the cartridge even after rinsing with saline could be infused into the patient. The risks associated with the intravenous injection of Polymyxin B include nephrotoxic and neurotoxic side effects which are exacerbated by impaired renal function, high serum levels of Polymyxin B and/or concurrent use of other nephrotoxic/neurotoxic drugs. Signs of nephrotoxicity caused by Polymyxin B include, but are not limited to, albuminuria, azotemia, rising BUN or urea and diminishing urine output. Signs of neurotoxicity include, but are not limited to, irritability, progressive weakness, drowsiness, ataxia, paresthesia, numbness, blurred vision and possible neuromuscular blockage.
7. PMX must be used carefully in the elderly, while monitoring their condition, because of their general decline in physiologic function.
8. The safety of PMX treatment has not been established in pregnant women and patients less than 18 years of age.
9. The safety of PMX-DHP performed directly in conjunction with the use of any other blood purification cartridge including continuous renal replacement therapy (CRRT) has not been established. It is recommended to carry out PMX-DHP prior to any other blood purification therapy if needed. If other blood purification therapy has already been initiated prior to the PMX-DHP, it is recommended to interrupt the blood purification therapy in order to carry out the PMX-DHP.
10. Check all connections of the extracorporeal circuit carefully prior to and during the procedure. At all times avoid kinking of the tubing lines and the vascular catheter.
11. If the extracorporeal circuit is equipped with a drip chamber, ensure that the drip chamber is at all times at least 2/3 to 3/4 full and monitored at all times in order to decrease the risk of air embolism.
12. Ensure that the fluid circuit for PMX-DHP, including the blood tubing and double lumen catheter for blood access is sterile and non-pyrogenic. Use aseptic handling techniques to maintain these conditions. Before use, check the packaging of all

the disposables to ensure that it is intact. Do not open the pouch containing the disposables until immediately prior to use.

13. Follow the normal practice of the healthcare facility with regard to screening for Hepatitis B and other infectious diseases. Universal precautions should be taken at all times to prevent exposure to and transmission of infectious agents.

### **Precautions relating to heparin administration**

1. The recommended heparin doses for PMX-DHP are as follows:

● Priming	4 Units (U)/mL <sup>(*)</sup>
● Bolus	3,000 U
● Maintenance	20 U/kg body weight/hr <sup>(**)</sup>

<sup>(\*)</sup> The heparin solution (2,000 U/ 500 mL physiological saline) is used for priming.

<sup>(\*\*)</sup> The maximum maintenance dose allowed for any patient is 2,000 U/hr.

2. The heparin doses described above and the ACT value described below (see 4.) are intended as general recommendations. The exact amount, frequency and method of administration of heparin are the sole responsibility of the prescribing/attending physician and should be selected based on the individual patient's clinical condition.
3. The heparin dose can be adjusted during and after PMX-DHP on the basis of clinical observation; ACT and/or PTT (prothrombin) values. (Some patients, in particular patients who have undergone surgery, may not be able to tolerate the above recommended levels of heparin. This may be due to: (1) presence of a continuous heparin infusion or regular administration of heparin prior to treatment with PMX-DHP and/or (2) high ACT or PTT value prior to treatment with PMX-DHP.)
4. Closely monitor patient clotting time at intervals during the procedure to ensure that an adequate level of anticoagulant is maintained. Adjust the continuous infusion of heparin based on the ACT or PTT measurement. Maintain ACT or PTT within the range 150 – 180 sec or 50 – 60 sec with a maximum of 240 sec or 100 sec, respectively. Blood for ACT or PTT measurement must be taken from the first sampling port on the inlet line (before the heparin line joins the inlet line).

### **Precautions for storage and handling**

1. The cartridge housing is made of plastic. Avoid any physical shock while transporting and handling, as damage to the housing or other components may result. Do not tap the cartridge with any metallic objects.
2. Store cartridge in a dry area at normal room temperature, away from direct sunlight. Do not freeze.
3. Use the cartridge before the "Use by" date given on the product label, preceded by the symbol.



### **Precautions before initiating PMX treatment**

1. Do not use the cartridge if any of the following conditions are observed, since sterility of the cartridge may have been compromised:
  - Any damage to the cartridge;
  - Any damage to the single-unit packaging (pouch) containing the cartridge, or if the pouch is opened;

- The presence of droplets on the inner surface of the pouch;
- Loose or absent end-caps on the inlet and/or outlet.

2. The cartridge has been sterilized by steam. Check the sterilization indicator on the single-unit packaging of the cartridge. The indicator changes to dark brown when the cartridge has been sterilized. If the indicator is whitish yellow the cartridge has not been sterilized. Do not use the cartridge if the sterilization indicator is whitish yellow.
3. Use aseptic handling technique, including the use of protective gloves and glasses, while connecting the blood infusion line to the cartridge and returning the blood from the cartridge.
4. The saline solution in the cartridge is acidic (about pH 2.0) due to steam sterilization. Use four (4) liters or more of physiological saline solution to rinse out the acidic solution in the cartridge and restore the physiological conditions so that they are compatible with human body fluid.
5. At all times ensure there is no fluid leakage between the blood tubing and the cartridge connector.
6. Do not allow air bubbles to enter the cartridge during the rinsing and priming procedure. Use the cartridge promptly after rinsing and priming.
7. Check also the following items before initiating PMX treatment:
  - Proper connection between the catheter and the blood tubing
  - Proper connection between the blood tubing and the inlet and outlet of the cartridge
  - Alarms and detectors of the hemoperfusion machine are operational.

### **Precautions during PMX treatment**

1. Ensure that the blood flow rate is maintained at a minimum of 80 mL/min during extracorporeal circulation, to avoid risk of stasis in the cartridge.
2. The inlet pressure must not exceed 66 kPa (500 mmHg). Inlet pressure higher than 66 kPa (500 mmHg) may cause leak in the cartridge or disconnection between the blood tubing and the cartridge connector.
3. Monitor the inlet and outlet pressures in the system during PMX-DHP.
4. If an unusual pressure difference (approx. 26.4 kPa (200 mmHg)) is observed between the inlet and outlet of the cartridge, clotting in the cartridge must be suspected. If the inlet pressure reaches 33 kPa (250 mmHg) stop the blood pump and recover the blood in accordance with the procedure (see "Abnormal Condition" in "Finishing Procedure").
5. Ensure there is no blood leakage between the blood tubing and cartridge connector.

### **Precautions at the end of PMX treatment**

1. Use sufficient normal physiological saline (approximately 500 mL) to ensure adequate blood return.
2. When recovering the blood, reverse the position of the cartridge, so that the arrow is pointing down, and allow the blood to flow in the direction of the arrow. This will reduce the amount of blood remaining within the cartridge.
3. When disposing of the cartridge and blood tubing, ensure compliance with all local requirements and the policy of the healthcare facility regarding precautions for and prevention of infection and environmental pollution.

## USE OF THE PMX CARTRIDGE

The procedures described below are indicated as general procedures. The prescribing/attending physician should select the appropriate procedures based on the specific tubing and machine used in the PMX treatment.

### Rinsing and Priming Procedure

Observe proper aseptic technique, including the use of protective gloves and glasses, while handling the cartridge and blood connections.

The following quantities of infusion solution will be needed:

- Physiological saline: at least 4 liters
- Heparinized saline: at least 500 mL
- Physiological saline (for blood return): approximately 500 mL

Refer to the instructions for use for the chosen blood tubing.

### Rinsing the blood tubing

1. Rinse and fill the arterial line with physiological saline and ensure that there are no air bubbles present.
2. **See Figure 2.** Put the drip chamber of the Venous line on a stand using a cartridge holder or clamp. Connect the pressure monitoring line to the outlet pressure (Po) monitor. Ensure that the connector of the fluid level adjusting line is closed, using a clamp if necessary. Clamp the Venous line near the catheter connector.
3. Place the cartridge in the normal position (arrow pointing up). Remove the cap on the outlet connector and attach the Venous line to it. Turn the cartridge upside down (arrow pointing down). Remove the cap from the cartridge inlet. Gently press the drip chamber of the Venous line to drive out any air in the cartridge inlet (**see Figure 3**). If any air bubbles remain, inject a small

amount of physiological saline, using a syringe. As soon as physiological saline is seen in the tip of the cartridge inlet, connect the Arterial line to the cartridge. During this process, take care to prevent air entering the connector. Return the cartridge to its normal position (arrow pointing up).

4. Remove the clamp near the catheter connector on the Venous line. Operate the blood pump to pass 4 liters or more of physiological saline at the flow rate of 100 mL/min. Be sure to flow the solution from bottom to top (from the arterial to the venous end) for adequate rinsing. At the start of rinsing, tap the cartridge gently with the hand and drive out the air bubbles, until no more bubbles come out of the cartridge. Do not tap the cartridge with any metallic objects.
5. After rinsing, stop the blood pump, and re-clamp near the catheter connector on the Venous line. Prepare to prime the lines and cartridge with heparinized saline as follows.

Figure 2

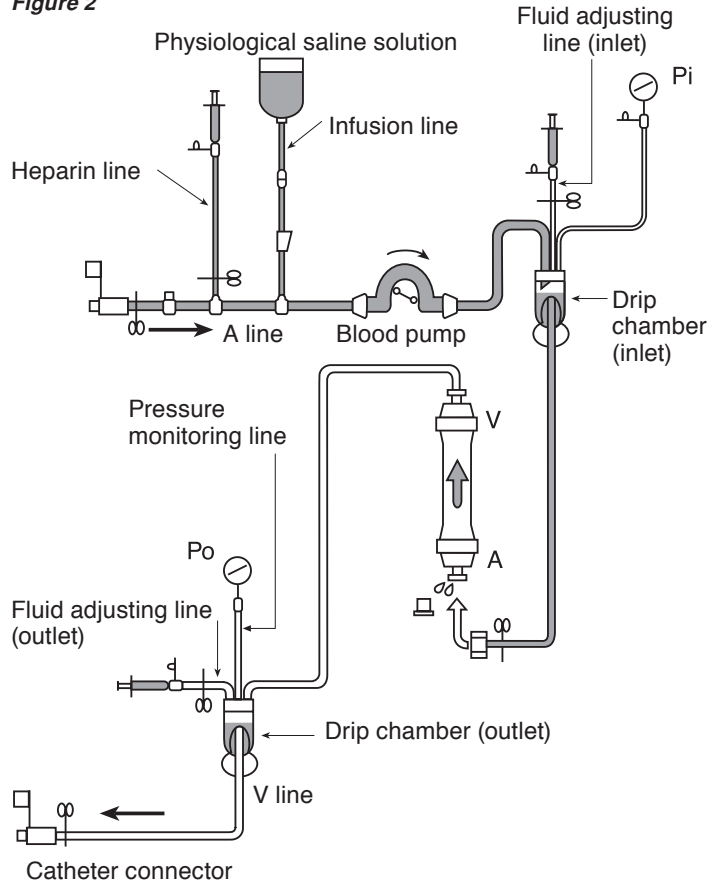

Figure 3

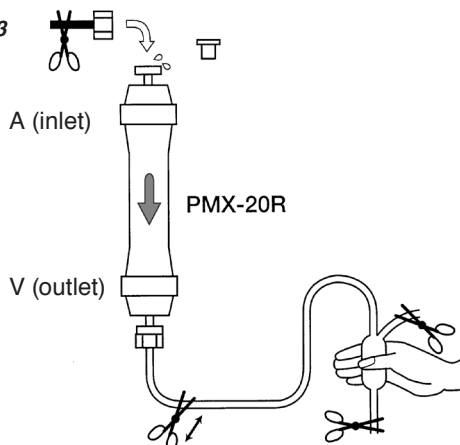
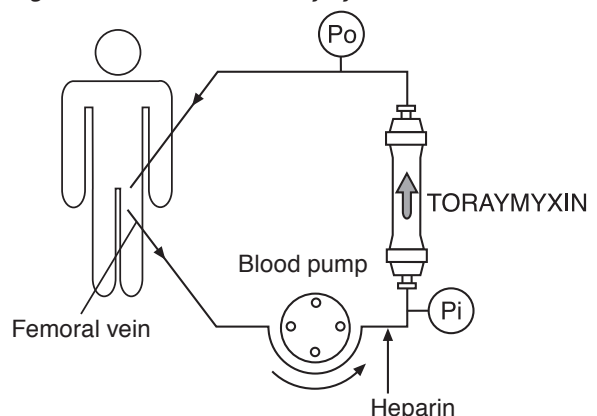

Figure 4: Clinical Use of Toraymyxin





### Priming the cartridge and blood lines

Ensure that priming is performed with heparinized saline.

1. Put 2,000 U of heparin into 500 mL of physiological saline (4 U/mL).
2. Connect a 500 mL bag of the heparinized saline to the infusion line.
3. Remove the clamp on the Venous line near the catheter connector. Operate the blood pump. Allow 500 mL of heparinized saline to flow, at a flow rate of 100 mL/min to replace the solution inside the cartridge and the tubing with heparinized saline.
4. During this process, also prime the inside of the heparin line and the lines on the inlet line.

### Operating Procedure (See Figure 4)

The basic conditions of the operating procedure are as follows:

- Method: direct hemoperfusion (DHP)
- Blood flow rate: 100 (80–120) mL/min
- Duration of DHP: 2 hours
- Anticoagulant: heparin 3,000 U as bolus and 20 U/kg body weight/hr as continuous infusion

1. Connect the Arterial line to the patient's catheter on the outlet lumen of the catheter.
2. Operate the blood pump, initially at a low flow rate. Monitor the patient's condition, and drive out approx. 10–20 mL of priming solution.
3. Connect the Venous line to the patient's catheter on the inlet lumen of the catheter (see Figure 5).
4. Ensure the cartridge is upright (arrow pointing up). Flow the blood from the arterial end up to the venous end following the direction of the arrow shown on the label and carry out DHP.
5. Administer the heparin bolus and then proceed with the continuous infusion. For heparin doses, refer to "Precautions relating to heparin administration" above.

6. Gradually increase the blood flow rate, and ensure that a blood flow rate of 100 (80-120) mL/min is maintained during extracorporeal circulation.
7. The duration of extracorporeal circulation is two (2) hours per cartridge.

### Finishing Procedure

#### Normal Condition

1. Prepare 500 mL of physiological saline as replacement fluid for blood recovery.
2. Once extracorporeal circulation has been completed, stop the blood pump. Lock the catheter on the Arterial line, clamp and remove the Arterial line from the patient. Reverse the position of the cartridge so that the arrow points down. Operate the blood pump, and while monitoring the patient's condition, flow 100-200 mL of physiological saline at a low flow rate (approx. 50 mL/min), to return the blood in the cartridge and tubing to the patient.
3. Lock the catheter at the Venous line, clamp and remove the Venous line from the patient.

#### Abnormal Condition (clotting within the cartridge)

1. If the inlet pressure reaches 33 kPa (250 mmHg), stop the blood pump.
2. Remove the Arterial line from the catheter. Operate the blood pump at a flow rate of approximately 50 mL/min, and return as much blood as possible from the blood tubing and cartridge to the patient, introducing approximately 100 mL of physiological saline through the infusion line.

### Disposing of the Cartridge

When disposing of the cartridge components and other tubing waste, ensure compliance with all local requirements and the policy of the healthcare facility regarding precautions for and prevention of infection and environmental pollution.

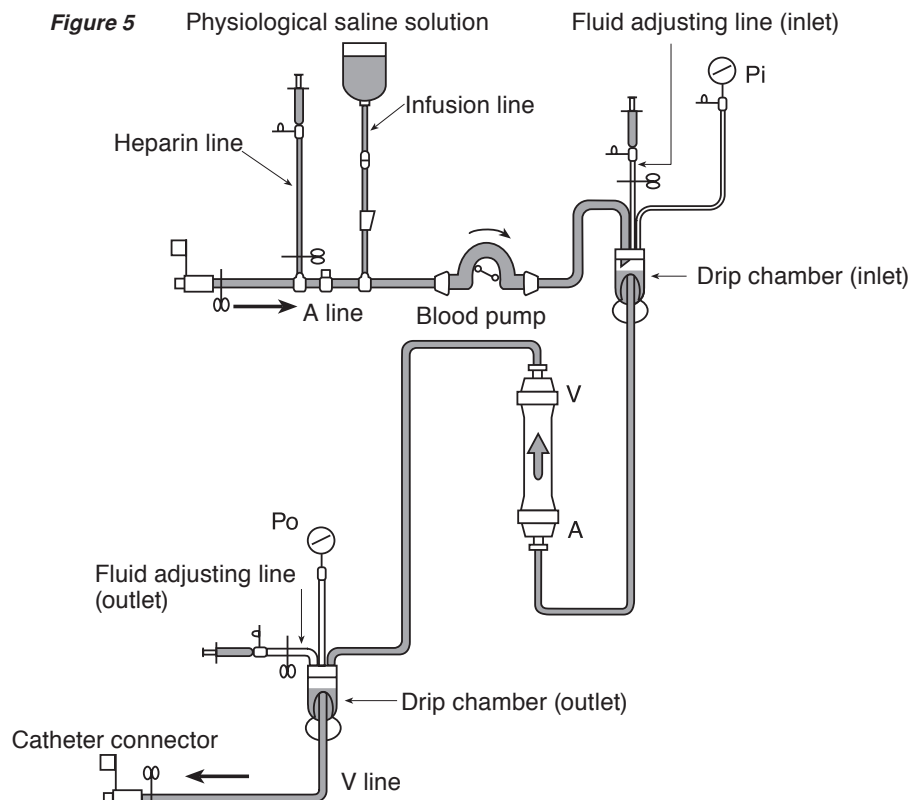

**Explanation of symbols used on the device labelling:**



Steam Sterilization



Serial No.



Read instructions before use



For single use only



Lot No.



Use by



Date of manufacture  
(Sterilization date)



Authorized Representative in the  
European Community

**REFERENCES**

- 1) Hisataka Shoji, Kazuyoshi Hanasawa, Masashi Kodama Extracorporeal endotoxin removal by Polymyxin-B immobilized fiber cartridge; designing and antiendotoxin efficacy in clinical application. *Therapeutic Apheresis* 1998; 2:3 –12.
- 2) Masashi Kodama, Tohru Tani, Kazuyoshi Hanasawa, et al. Treatment of sepsis by plasma endotoxin removal; hemoperfusion using a polymyxin-B immobilized column. *J. Endotoxin Res.* 1997; 4: 293 – 300.
- 3) Tohru Tani, Kazuyoshi Hanasawa, Yoshihiro Endo, et al. Therapeutic apheresis for septic patients with organ dysfunction: Hemoperfusion using a polymyxin-B immobilized column. *Artificial Organs* 1998; 22: 1038 –1044.

**WARRANTY LIMITATIONS**

The manufacturer, Toray Industries Inc., warrants that the TORAYMYXIN PMX-20R cartridge (cartridge) has been manufactured in accordance with their specifications and in compliance with good manufacturing practices, other applicable industry standards and regulatory requirements. Toray Industries Inc.'s quality system is operated in accordance with International and European standards for quality systems, as assessed by the Notified Body TÜV SÜD Product Service.

The manufacturer shall not be liable for any misuse, improper handling, operation or storage, non-compliance with the warnings and instructions for use, damage arising from events after the manufacturer's release of the cartridge including use after the labeled expiration date. In addition, Toray Industries Inc. is not responsible for any damage caused by reprocessing or reuse of the cartridge.

# 'TORAY'



**Manufacturer:**

**Toray Industries, Inc.**

1-1, Nihonbashi-Muromachi 2-chome, Chuo-ku, Tokyo 103-8666, JAPAN

**Exporter:**

**Toray Medical Co., Ltd.**

8-1, Mihama 1-chome, Urayasu, Chiba 279-8555, JAPAN



**Toray International Italy S.r.l.**

Via Mecenate 86, 20138 Milan, ITALY

Appendix 5, 2012 Surviving Sepsis Campaign Guidelines





# Surviving Sepsis Campaign: International Guidelines for Management of Severe Sepsis and Septic Shock: 2012

R. Phillip Dellinger, MD<sup>1</sup>; Mitchell M. Levy, MD<sup>2</sup>; Andrew Rhodes, MB BS<sup>3</sup>; Djillali Annane, MD<sup>4</sup>; Herwig Gerlach, MD, PhD<sup>5</sup>; Steven M. Opal, MD<sup>6</sup>; Jonathan E. Sevransky, MD<sup>7</sup>; Charles L. Sprung, MD<sup>8</sup>; Ivor S. Douglas, MD<sup>9</sup>; Roman Jaeschke, MD<sup>10</sup>; Tiffany M. Osborn, MD, MPH<sup>11</sup>; Mark E. Nunnally, MD<sup>12</sup>; Sean R. Townsend, MD<sup>13</sup>; Konrad Reinhart, MD<sup>14</sup>; Ruth M. Kleinpell, PhD, RN-CS<sup>15</sup>; Derek C. Angus, MD, MPH<sup>16</sup>; Clifford S. Deutschman, MD, MS<sup>17</sup>; Flavia R. Machado, MD, PhD<sup>18</sup>; Gordon D. Rubenfeld, MD<sup>19</sup>; Steven A. Webb, MB BS, PhD<sup>20</sup>; Richard J. Beale, MB BS<sup>21</sup>; Jean-Louis Vincent, MD, PhD<sup>22</sup>; Rui Moreno, MD, PhD<sup>23</sup>; and the Surviving Sepsis Campaign Guidelines Committee including the Pediatric Subgroup\*

**Objective:** To provide an update to the “Surviving Sepsis Campaign Guidelines for Management of Severe Sepsis and Septic Shock,” last published in 2008.

**Design:** A consensus committee of 68 international experts representing 30 international organizations was convened. Nominal groups were assembled at key international meetings (for those committee members attending the conference). A formal conflict of interest policy was developed at the onset of the process and enforced throughout. The entire guidelines process was conducted independent of any industry funding. A stand-alone meeting was held for all subgroup heads, co- and vice-chairs, and selected individuals. Teleconferences and electronic-based discussion among subgroups and among the entire committee served as an integral part of the development.

**Methods:** The authors were advised to follow the principles of the Grading of Recommendations Assessment, Development and Evaluation (GRADE) system to guide assessment of quality of evidence from high (A) to very low (D) and to determine the strength of recommendations as strong (1) or weak (2). The potential drawbacks of making strong recommendations in the presence of low-quality evidence were emphasized. Some recommendations were ungraded (UG). Recommendations were classified into three groups: 1) those directly targeting severe sepsis; 2) those targeting general care of the critically ill patient and considered high priority in severe sepsis; and 3) pediatric considerations.

**Results:** Key recommendations and suggestions, listed by category, include: early quantitative resuscitation of the septic patient during the first 6 hrs after recognition (1C); blood cultures

<sup>1</sup> Cooper University Hospital, Camden, New Jersey.  
<sup>2</sup> Warren Alpert Medical School of Brown University, Providence, Rhode Island.  
<sup>3</sup> St. George's Hospital, London, United Kingdom.  
<sup>4</sup> Hôpital Raymond Poincaré, Garches, France.  
<sup>5</sup> Vivantes-Klinikum Neukölln, Berlin, Germany.  
<sup>6</sup> Memorial Hospital of Rhode Island, Pawtucket, Rhode Island.  
<sup>7</sup> Emory University Hospital, Atlanta, Georgia.  
<sup>8</sup> Hadassah Hebrew University Medical Center, Jerusalem, Israel.  
<sup>9</sup> Denver Health Medical Center, Denver, Colorado.  
<sup>10</sup> McMaster University, Hamilton, Ontario, Canada.  
<sup>11</sup> Barnes-Jewish Hospital, St. Louis, Missouri.  
<sup>12</sup> University of Chicago Medical Center, Chicago, Illinois.  
<sup>13</sup> California Pacific Medical Center, San Francisco, California.  
<sup>14</sup> Friedrich Schiller University Jena, Jena, Germany.  
<sup>15</sup> Rush University Medical Center, Chicago, Illinois.  
<sup>16</sup> University of Pittsburgh, Pittsburgh, Pennsylvania.  
<sup>17</sup> Perelman School of Medicine at the University of Pennsylvania, Philadelphia, Pennsylvania.  
<sup>18</sup> Federal University of Sao Paulo, Sao Paulo, Brazil.  
<sup>19</sup> Sunnybrook Health Sciences Center, Toronto, Ontario, Canada.

<sup>20</sup> Royal Perth Hospital, Perth, Western Australia.  
<sup>21</sup> Guy's and St. Thomas' Hospital Trust, London, United Kingdom.  
<sup>22</sup> Erasme University Hospital, Brussels, Belgium.  
<sup>23</sup> UCINC, Hospital de São José, Centro Hospitalar de Lisboa Central, E.P.E., Lisbon, Portugal.

\* Members of the 2012 SSC Guidelines Committee and Pediatric Subgroup are listed in **Appendix A** at the end of this article.

Supplemental digital content is available for this article. Direct URL citations appear in the printed text and are provided in the HTML and PDF versions of this on the journal's Web site (<http://journals.lww.com/ccmjournal>).

Complete author and committee disclosures are listed in **Supplemental Digital Content 1** (<http://links.lww.com/CCM/A615>).

This article is being simultaneously published in *Critical Care Medicine* and *Intensive Care Medicine*.

For additional information regarding this article, contact R.P. Dellinger (Dellinger-Phil@CooperHealth.edu).

Copyright © 2013 by the Society of Critical Care Medicine and the European Society of Intensive Care Medicine

**DOI: 10.1097/CCM.0b013e31827e83af**

before antibiotic therapy (1C); imaging studies performed promptly to confirm a potential source of infection (UG); administration of broad-spectrum antimicrobials therapy within 1 hr of recognition of septic shock (1B) and severe sepsis without septic shock (1C) as the goal of therapy; reassessment of antimicrobial therapy daily for de-escalation, when appropriate (1B); infection source control with attention to the balance of risks and benefits of the chosen method within 12 hrs of diagnosis (1C); initial fluid resuscitation with crystalloid (1B) and consideration of the addition of albumin in patients who continue to require substantial amounts of crystalloid to maintain adequate mean arterial pressure (2C) and the avoidance of hetastarch formulations (1C); initial fluid challenge in patients with sepsis-induced tissue hypoperfusion and suspicion of hypovolemia to achieve a minimum of 30 mL/kg of crystalloids (more rapid administration and greater amounts of fluid may be needed in some patients) (1C); fluid challenge technique continued as long as hemodynamic improvement, as based on either dynamic or static variables (UG); norepinephrine as the first-choice vasopressor to maintain mean arterial pressure  $\geq$  65 mm Hg (1B); epinephrine when an additional agent is needed to maintain adequate blood pressure (2B); vasopressin (0.03 U/min) can be added to norepinephrine to either raise mean arterial pressure to target or to decrease norepinephrine dose but should not be used as the initial vasopressor (UG); dopamine is not recommended except in highly selected circumstances (2C); dobutamine infusion administered or added to vasopressor in the presence of a) myocardial dysfunction as suggested by elevated cardiac filling pressures and low cardiac output, or b) ongoing signs of hypoperfusion despite achieving adequate intravascular volume and adequate mean arterial pressure (1C); avoiding use of intravenous hydrocortisone in adult septic shock patients if adequate fluid resuscitation and vasopressor therapy are able to restore hemodynamic stability (2C); hemoglobin target of 7–9 g/dL in the absence of tissue hypoperfusion, ischemic coronary artery disease, or acute hemorrhage (1B); low tidal volume (1A) and limitation of inspiratory plateau pressure (1B) for acute respiratory distress syndrome (ARDS); application of at least a minimal amount of positive end-expiratory pressure (PEEP) in ARDS (1B); higher rather than lower level of PEEP for patients with sepsis-induced moderate or severe ARDS (2C); recruitment maneuvers in sepsis patients with severe refractory hypoxemia due to ARDS (2C); prone positioning in sepsis-induced ARDS patients with a  $\text{PaO}_2/\text{FiO}_2$  ratio of  $\leq$  100 mm Hg in facilities that have experience with such practices (2C); head-of-bed elevation in mechanically ventilated patients

unless contraindicated (1B); a conservative fluid strategy for patients with established ARDS who do not have evidence of tissue hypoperfusion (1C); protocols for weaning and sedation (1A); minimizing use of either intermittent bolus sedation or continuous infusion sedation targeting specific titration endpoints (1B); avoidance of neuromuscular blockers if possible in the septic patient *without* ARDS (1C); a short course of neuromuscular blocker (no longer than 48 hrs) for patients *with* early ARDS and a  $\text{PaO}_2/\text{FiO}_2 < 150$  mm Hg (2C); a protocolized approach to blood glucose management commencing insulin dosing when two consecutive blood glucose levels are  $> 180$  mg/dL, targeting an upper blood glucose  $\leq 180$  mg/dL (1A); equivalency of continuous veno-venous hemofiltration or intermittent hemodialysis (2B); prophylaxis for deep vein thrombosis (1B); use of stress ulcer prophylaxis to prevent upper gastrointestinal bleeding in patients with bleeding risk factors (1B); oral or enteral (if necessary) feedings, as tolerated, rather than either complete fasting or provision of only intravenous glucose within the first 48 hrs after a diagnosis of severe sepsis/septic shock (2C); and addressing goals of care, including treatment plans and end-of-life planning (as appropriate) (1B), as early as feasible, but within 72 hrs of intensive care unit admission (2C). Recommendations specific to pediatric severe sepsis include: therapy with face mask oxygen, high flow nasal cannula oxygen, or nasopharyngeal continuous PEEP in the presence of respiratory distress and hypoxemia (2C), use of physical examination therapeutic endpoints such as capillary refill (2C); for septic shock associated with hypovolemia, the use of crystalloids or albumin to deliver a bolus of 20 mL/kg of crystalloids (or albumin equivalent) over 5 to 10 mins (2C); more common use of inotropes and vasodilators for low cardiac output septic shock associated with elevated systemic vascular resistance (2C); and use of hydrocortisone only in children with suspected or proven “absolute” adrenal insufficiency (2C).

**Conclusions:** Strong agreement existed among a large cohort of international experts regarding many level 1 recommendations for the best care of patients with severe sepsis. Although a significant number of aspects of care have relatively weak support, evidence-based recommendations regarding the acute management of sepsis and septic shock are the foundation of improved outcomes for this important group of critically ill patients. (*Crit Care Med* 2013; 41:580–637)

**Key Words:** evidence-based medicine; Grading of Recommendations Assessment, Development and Evaluation criteria; guidelines; infection; sepsis; sepsis bundles; sepsis syndrome; septic shock; severe sepsis; Surviving Sepsis Campaign

Sponsoring organizations: American Association of Critical-Care Nurses, American College of Chest Physicians, American College of Emergency Physicians, American Thoracic Society, Asia Pacific Association of Critical Care Medicine, Australian and New Zealand Intensive Care Society, Brazilian Society of Critical Care, Canadian Critical Care Society, Chinese Society of Critical Care Medicine, Chinese Society of Critical Care Medicine—China Medical Association, Emirates Intensive Care Society, European Respiratory Society, European Society of Clinical Microbiology and Infectious Diseases, European Society of Intensive Care Medicine, European Society of Pediatric and Neonatal Intensive Care, Infectious Diseases Society of

America, Indian Society of Critical Care Medicine, International Pan Arabian Critical Care Medicine Society, Japanese Association for Acute Medicine, Japanese Society of Intensive Care Medicine, Pediatric Acute Lung Injury and Sepsis Investigators, Society for Academic Emergency Medicine, Society of Critical Care Medicine, Society of Hospital Medicine, Surgical Infection Society, World Federation of Critical Care Nurses, World Federation of Pediatric Intensive and Critical Care Societies; World Federation of Societies of Intensive and Critical Care Medicine. Participation and endorsement: The German Sepsis Society and the Latin American Sepsis Institute.

Dr. Dellinger consulted for Biotest (immunoglobulin concentrate available in Europe for potential use in sepsis) and AstraZeneca (anti-TNF compound unsuccessful in recently completed sepsis clinical trial); his institution received consulting income from IKARIA for new product development (IKARIA has inhaled nitric oxide available for off-label use in ARDS) and grant support from Spectral Diagnostics Inc (current endotoxin removal clinical trial), Ferring (vasopressin analog clinical trial-ongoing); as well as serving on speakers bureau for Eisai (anti-endotoxin compound that failed to show benefit in clinical trial).

Dr. Levy received grant support from Eisai (Ocean State Clinical Coordinating Center to fund clinical trial [\$500K]), he received honoraria from Eli Lilly (lectures in India \$8,000), and he has been involved with the Surviving Sepsis Campaign guideline from its beginning.

Dr. Rhodes consulted for Eli Lilly with monetary compensation paid to himself as well as his institution (Steering Committee for the PROWESS Shock trial) and LiDCO; travel/accommodation reimbursement was received from Eli Lilly and LiDCO; he received income for participation in review activities such as data monitoring boards, statistical analysis from Orion, and for Eli Lilly; he is an author on manuscripts describing early goal-directed therapy, and believes in the concept of minimally invasive hemodynamic monitoring.

Dr. Annane participated on the Fresenius Kabi International Advisory Board (honorarium 2000€). His nonfinancial disclosures include being the principal investigator of a completed investigator-led multicenter randomized controlled trial assessing the early guided benefit to risk of NIRS tissue oxygen saturation; he was the principal investigator of an investigator-led randomized controlled trial of epinephrine vs norepinephrine (CATS study)—*Lancet* 2007; he also is the principle investigator of an ongoing investigator-led multinational randomized controlled trial of crystalloids vs colloids (Crystal Study).

Dr. Gerlach has disclosed that he has no potential conflicts of interest; he is an author of a review on the use of activated protein C in surgical patients (published in the *New England Journal of Medicine*, 2009).

Dr. Opal consulted for Genzyme Transgenics (consultant on transgenic antithrombin \$1,000), Pfizer (consultant on TLR4 inhibitor project \$3,000), British Therapeutics (consultant on polyclonal antibody project \$1,000), and Biotest A (consultant on immunoglobulin project \$2,000). His institution received grant support from Novartis (Clinical Coordinating Center to assist in patient enrollment in a phase III trial with the use of Tissue Factor Pathway Inhibitor [TFPI] in severe community acquired pneumonia [SCAP] \$30,000 for 2 years), Eisai (\$30,000 for 3 years), Astra Zeneca (\$30,000 for 1 year), Aggenix (\$30,000 for 1 year), Inimex (\$10,000), Eisai (\$10,000), Atoxbio (\$10,000), Wyeth (\$20,000), Sirtris (preclinical research \$50,000), and Cellular Bioengineering Inc. (\$500). He received honoraria from Novartis (clinical evaluation committee TFPI study for SCAP \$20,000) and Eisai (\$25,000). He received travel/accommodations reimbursed from Sangart (data and safety monitoring \$2,000), Spectral Diagnostics (data and safety monitoring \$2,000), Takeda (data and safety monitoring \$2,000) and Canadian trials group ROS II oseltamivir study (data and safety monitoring board (no money)). He is also on the Data Safety Monitoring Board for Tetrphase (received US \$600 in 2012).

Dr. Sevransky received grant support to his institution from Sirius Genomics Inc; he consulted for Idaho Technology (\$1,500); he is the co-principal investigator of a multicenter study evaluating the association between intensive care unit organizational and structural factors, including protocols and in-patient mortality. He maintains that protocols serve as useful reminders to busy clinicians to consider certain therapies in patients with sepsis or other life-threatening illness.

Dr. Sprung received grants paid to his institution from Artisan Pharma (\$25,000–\$50,000), Eisai, Corp (\$1,000–\$5,000 ACCESS), Ferring Pharmaceuticals A/S (\$5,000–\$10,000), Hutchinson Technology Incorporated (\$1,000–\$5,000), Novartis Corp (less than \$1,000). His institution receives grant support for patients enrolled in clinical studies from Eisai Corporation (PI. Patients enrolled in the ACCESS study \$50,000–\$100,000), Takeda (PI. Study terminated before patients enrolled). He received grants paid to his institution and consulting income from Artisan Pharma/Asahi Kasei Pharma America Corp (\$25,000–\$50,000). He consulted for Eli Lilly (Sabbatical Consulting fee \$10,000–\$25,000) and received honoraria from Eli Lilly (lecture \$1,000–\$5,000). He is a member of the Australia and New Zealand Intensive Care Society Clinical Trials Group for the NICE-SUGAR Study (no money received); he is a council member of the International Sepsis Forum (as of Oct. 2010); he has held long time research interests in steroids in sepsis, PI of Corticus study, end-of-life decision making and PI of Ethicus, Ethicatt, and Welpicus studies.

Dr. Douglas received grants paid to his institution from Eli Lilly (PROWESS Shock site), Eisai (study site), National Institutes of Health (ARDS Network), Accel8 (VAP diagnostics), CCCTG (Oscillate Study), and Hospira (Dexametomidine in Alcohol Withdrawal RCT). His institution received an honorarium from the Society of Critical Care Medicine (Paragon ICU Improvement); he consulted for Eli Lilly (PROWESS Shock SC and Sepsis Genomics Study) in accordance with institutional policy; he received payment for providing expert testimony (Smith Moore Leatherwood LLP); travel/accommodations reimbursed by Eli Lilly and Company (PROWESS Shock Steering Committee) and the Society of Critical Care Medicine (Hospital Quality Alliance, Washington DC, four times per year 2009–2011); he received honoraria from Covidien (non-CME lecture 2010, US\$500) and the University of Minnesota Center for Excellence in Critical Care CME program (2009, 2010); he has a pending patent for a bed backrest elevation monitor.

Dr. Jaeschke has disclosed that he has no potential conflicts of interest.

Dr. Osborn consulted for Sui Generis Health (\$200). Her institution receives grant support from the National Institutes of Health Research, Health Technology Assessment Programme-United Kingdom (trial doctor for sepsis-related RCT). Salary paid through the NIH government funded (nonindustry) grant. Grant awarded to chief investigator from ICNARC. She is a trial clinician for ProMISE.

Dr. Nunnally received a stipend for a chapter on diabetes mellitus; he is an author of editorials contesting classic tight glucose control.

Dr. Townsend is an advocate for healthcare quality improvement.

Dr. Reinhart consulted for EISAI (Steering Committee member—less than US \$10,000); BRAHMS Diagnostics (less than US \$10,000); and SIRS-Lab Jena (founding member, less than US \$10,000). He received honoraria for lectures including service on the speakers' bureau from Biosyn Germany (less than €10,000) and Braun Melsungen (less than €10,000). He received royalties from Edwards Life Sciences for sales of central venous oxygen catheters (~\$100,000).

Dr. Kleinpell received monetary compensation for providing expert testimony (four depositions and one trial in the past year). Her institution receives grants from the Agency for Healthcare Research and Quality and the Prince Foundation (4-year R01 grant, PI and 3-year foundation grant, Co-I). She received honoraria from the Cleveland Clinic and the American Association of Critical Care Nurses for keynote speeches at conferences; she received royalties from McGraw Hill (co-editor of critical care review book); travel/accommodations reimbursed from the American Academy of Nurse Practitioners, Society of Critical Care Medicine, and American Association of Critical Care Nurses (one night hotel coverage at national conference).

Dr. Angus consulted for Eli Lilly (member of the Data Safety Monitoring Board, Multicenter trial of a PC for septic shock), Eisai Inc (Anti-TLR4 therapy for severe sepsis), and Idaho Technology (sepsis biomarkers); he received grant support (investigator, long-term follow-up of phase III trial of an anti-TLR4 agent in severe sepsis), a consulting income (anti-TLR4 therapy for severe sepsis), and travel/accommodation expense reimbursement from Eisai, Inc; he is the primary investigator for an ongoing National Institutes of Health-funded study comparing early resuscitation strategies for sepsis-induced tissue hypoperfusion.

Dr. Deutschman has nonfinancial involvement as a coauthor of the Society of Critical Care Medicine's Glycemic Control guidelines.

Dr. Machado reports unrestricted grant support paid to her institution for Surviving Sepsis Campaign implementation in Brazil (Eli Lilly do Brasil); she is the primary investigator for an ongoing study involving vasopressin.

Dr. Rubenfeld received grant support from nonprofit agencies or foundations including National Institutes of Health (\$10 million), Robert Wood Johnson Foundation (\$500,000), and CIHR (\$200,000). His institution received grants from for-profit companies including Advanced Lifeline System (\$150,000), Siemens (\$50,000), Bayer (\$10,000), Byk Gulden (\$15,000), AstraZeneca (\$10,000), Faron Pharmaceuticals (\$5,000), and Cerus Corporation (\$11,000). He received honoraria, consulting fees, editorship, royalties, and Data and Safety Monitoring Board membership fees paid to him from Bayer (\$500), DHD (\$1,000), Eli Lilly (\$5,000), Oxford University Press (\$10,000), Hospira (\$15,000), Cerner (\$5,000), Pfizer (\$1,000), KCI (\$7,500), American Association for Respiratory Care (\$10,000), American Thoracic Society (\$7,500), BioMed Central (\$1,000), National Institutes of Health (\$1,500), and the Alberta Heritage Foundation for Medical Research (\$250). He has database access or other intellectual (non financial) support from Cerner.

Dr. Webb consulted for AstraZeneca (anti-infectives \$1,000–\$5,000) and Jansen-Cilag (anti-infectives \$1,000–\$5,000). He received grant support



from a NHMRC project grant (ARISE RECT of EGDT); NHMRC project grant and Fresenius-unrestricted grant (CHEST RCT of voluven vs. saline); RCT of steroid vs. placebo for septic shock); NHMRC project grant (BLISS study of bacteria detection by PRC in septic shock) Intensive Care Foundation-ANZ (BLING pilot RCT of beta-lactam administration by infusion); Hospira (SPICE programme of sedation delirium research); NHMRC Centres for Research Excellent Grant (critical illness microbiology observational studies); Hospira-unrestricted grant (DAHlia RCT of dexmedetomidine for agitated delirium). Travel/accommodations reimbursed by Jansen-Cilag (\$5,000–\$10,000) and AstraZeneca (\$1,000–\$5,000); he has a patent for a meningococcal vaccine. He is chair of the ANZICS Clinical Trials Group and is an investigator in trials of EGDT, PCR for determining bacterial load and a steroid in the septic shock trial.

Dr. Beale received compensation for his participation as board member for Eisai, Inc, Applied Physiology, bioMérieux, Covidien, SIRS-Lab, and Novartis; consulting income was paid to his institution from PriceSpective Ltd, Easton Associates (soluble guanilate cyclase activator in acute respiratory distress syndrome/acute lung injury adjunct therapy to supportive care and ventilation strategies), Eisai (eritoran), and Phillips (Respironics); he provided expert testimony for Eli Lilly and Company (paid to his institution); honoraria received (paid to his institution) from Applied Physiology (Applied Physiology PL SAB, Applied Physiology SAB, Brussels, Satellite Symposium at the ISICEM, Brussels), bioMérieux (GeneXpert Focus Group, France), SIRS-Lab (SIRS-LAB SAB Forum, Brussels and SIRS-LAB SAB, Lisbon), Eli Lilly (CHMP Hearing), Eisai (eritoran through leader touch plan in Brussels), Eli Lilly (Lunchtime Symposium, Vienna), Covidien (adult monitoring advisory board meeting, Frankfurt), Covidien (Global Advisory Board CNIBP Boulder USA),

Eli Lilly and Company (development of educational presentations including service on speaker' bureaus (intensive care school hosted in department); travel/accommodations were reimbursed from bioMérieux (GeneXpert Focus Group, France) and LiDCO (Winter Anaesthetic and Critical Care Review Conference), Surviving Sepsis Campaign (Publications Meeting, New York; Care Bundles Conference, Manchester), SSC Publication Committee Meeting and SSC Executive Committee Meeting, Nashville; SSC Meeting, Manchester), Novartis (Advisory Board Meeting, Zurich), Institute of Biomedical Engineering (Hospital of the Future Grand Challenge Kick-Off Meeting, Hospital of the Future Grand Challenge Interviews EPSRC Headquarters, Swindon, Philips (Kick-Off Meeting, Boeblingen, Germany; MET Conference, Copenhagen), Covidien (Adult Monitoring Advisory Board Meeting, Frankfurt), Eisai (ACCESS Investigators Meeting, Barcelona). His nonfinancial disclosures include authorship of the position statement on fluid resuscitation from the ESICM task force on colloids (yet to be finalized).

Dr. Vincent reports consulting income paid to his institution from Astellas, AstraZeneca, CuracYTE, Eli Lilly, Eisai, Ferring, GlaxoSmithKline, Merck, and Pfizer. His institution received honoraria on his behalf from Astellas, AstraZeneca, CuracYTE, Eli Lilly, Eisai, Ferring, Merck, and Pfizer. His institution received grant support from Astellas, CuracYTE, Eli Lilly, Eisai, Ferring, and Pfizer. His institution received payment for educational presentations from Astellas, AstraZeneca, CuracYTE, Eli Lilly, Eisai, Ferring, Merck, and Pfizer.

Dr. Moreno consulted for bioMérieux (expert meeting). He is a coauthor of a paper on corticosteroids in patients with septic shock. He is the author of several manuscripts defining sepsis and stratification of the patient with sepsis. He is also the author of several manuscripts contesting the utility of sepsis bundles.

**S**epsis is a systemic, deleterious host response to infection leading to severe sepsis (acute organ dysfunction secondary to documented or suspected infection) and septic shock (severe sepsis plus hypotension not reversed with fluid resuscitation). Severe sepsis and septic shock are major health-care problems, affecting millions of people around the world each year, killing one in four (and often more), and increasing in incidence (1–5). Similar to polytrauma, acute myocardial infarction, or stroke, the speed and appropriateness of therapy administered in the initial hours after severe sepsis develops are likely to influence outcome.

The recommendations in this document are intended to provide guidance for the clinician caring for a patient with severe sepsis or septic shock. Recommendations from these guidelines cannot replace the clinician's decision-making capability when he or she is presented with a patient's unique set of clinical variables. Most of these recommendations are appropriate for the severe sepsis patient in the ICU and non-ICU settings. In fact, the committee believes that the greatest outcome improvement can be made through education and process change for those caring for severe sepsis patients in the non-ICU setting and across the spectrum of acute care. Resource limitations in some institutions and countries may prevent physicians from accomplishing particular recommendations. Thus, these recommendations are intended to be best practice (the committee considers this a goal for clinical practice) and not created to represent standard of care. The Surviving Sepsis Campaign (SSC) Guidelines Committee hopes that over time, particularly through education programs and formal audit and feedback performance improvement initiatives, the guidelines will influence bedside healthcare practitioner behavior that will reduce the burden of sepsis worldwide.

## METHODOLOGY

### Definitions

Sepsis is defined as the presence (probable or documented) of infection together with systemic manifestations of infection. Severe sepsis is defined as sepsis plus sepsis-induced organ dysfunction or tissue hypoperfusion (**Tables 1 and 2**) (6). Throughout this manuscript and the performance improvement bundles, which are included, a distinction is made between definitions and therapeutic targets or thresholds. Sepsis-induced hypotension is defined as a systolic blood pressure (SBP) < 90 mm Hg or mean arterial pressure (MAP) < 70 mm Hg or a SBP decrease > 40 mm Hg or less than two standard deviations below normal for age in the absence of other causes of hypotension. An example of a therapeutic target or typical threshold for the reversal of hypotension is seen in the sepsis bundles for the use of vasopressors. In the bundles, the MAP *threshold* is  $\geq 65$  mm Hg. The use of *definition vs. threshold* will be evident throughout this article. Septic shock is defined as sepsis-induced hypotension persisting despite adequate fluid resuscitation. Sepsis-induced tissue hypoperfusion is defined as infection-induced hypotension, elevated lactate, or oliguria.

### History of the Guidelines

These clinical practice guidelines are a revision of the 2008 SSC guidelines for the management of severe sepsis and septic shock (7). The initial SSC guidelines were published in 2004 (8) and incorporated the evidence available through the end of 2003. The 2008 publication analyzed evidence available through the end of 2007. The most current iteration is based on updated literature search incorporated into the evolving manuscript through fall 2012.

## Selection and Organization of Committee Members

The selection of committee members was based on interest and expertise in specific aspects of sepsis. Co-chairs and executive committee members were appointed by the Society of Critical Care Medicine and European Society of Intensive Care Medicine governing bodies. Each sponsoring organization appointed a representative who had sepsis expertise. Additional committee members were appointed by the co-chairs and executive committee to create continuity with the previous committees' membership as well as to address content needs for the development process. Four clinicians with experience in the GRADE process application (referred to in this document as GRADE group or Evidence-Based Medicine [EBM] group) took part in the guidelines development.

The guidelines development process began with appointment of group heads and assignment of committee members to groups according to their specific expertise. Each group was responsible for drafting the initial update to the 2008 edition in their assigned area (with major additional elements of information incorporated into the evolving manuscript through year-end 2011 and early 2012).

With input from the EBM group, an initial group meeting was held to establish procedures for literature review and development of tables for evidence analysis. Committees and their subgroups continued work via phone and the Internet. Several subsequent meetings of subgroups and key individuals occurred at major international meetings (nominal groups), with work continuing via teleconferences and electronic-based discussions among subgroups and members of the entire committee. Ultimately, a meeting of all group heads, executive committee members, and other key committee members was held to finalize the draft document for submission to reviewers.

## Search Techniques

A separate literature search was performed for each clearly defined question. The committee chairs worked with subgroup heads to identify pertinent search terms that were to include, at a minimum, *sepsis*, *severe sepsis*, *septic shock*, and *sepsis syndrome* crossed against the subgroup's general topic area, as well as appropriate key words of the specific question posed. All questions used in the previous guidelines publications were searched, as were pertinent new questions generated by general topic-related searches or recent trials. The authors were specifically asked to look for existing meta-analyses related to their question and search a minimum of one general database (ie, MEDLINE, EMBASE) and the Cochrane Library (both The Cochrane Database of Systematic Reviews [CDSR] and Database of Abstracts of Reviews of Effectiveness [DARE]). Other databases were optional (ACP Journal Club, *Evidence-Based Medicine Journal*, Cochrane Registry of Controlled Clinical Trials, International Standard Randomized Controlled Trial Registry [<http://www.controlled-trials.com/isrctn/>] or metaRegister of Controlled Trials [<http://www.controlled-trials.com/mrct/>]). Where appropriate, available evidence was summarized in the form of evidence tables.

## Grading of Recommendations

We advised the authors to follow the principles of the Grading of Recommendations Assessment, Development and Evaluation (GRADE) system to guide assessment of quality of evidence from high (A) to very low (D) and to determine the strength of recommendations (Tables 3 and 4). (9–11). The SSC Steering Committee and individual authors collaborated with GRADE representatives to apply the system during the SSC guidelines revision process. The members of the GRADE group were directly involved, either in person or via e-mail, in all discussions and deliberations among the guidelines committee members as to grading decisions.

The GRADE system is based on a sequential assessment of the quality of evidence, followed by assessment of the balance between the benefits and risks, burden, and cost, leading to development and grading of a management recommendation. Keeping the rating of quality of evidence and strength of recommendation explicitly separate constitutes a crucial and defining feature of the GRADE approach. This system classifies quality of evidence as high (grade A), moderate (grade B), low (grade C), or very low (grade D). Randomized trials begin as high-quality evidence but may be downgraded due to limitations in implementation, inconsistency, or imprecision of the results, indirectness of the evidence, and possible reporting bias (Table 3). Examples of indirectness of the evidence include population studied, interventions used, outcomes measured, and how these relate to the question of interest. Well-done observational (nonrandomized) studies begin as low-quality evidence, but the quality level may be upgraded on the basis of a large magnitude of effect. An example of this is the quality of evidence for early administration of antibiotics. References to supplemental digital content appendices of GRADEpro Summary of Evidence Tables appear throughout this document.

The GRADE system classifies recommendations as strong (grade 1) or weak (grade 2). The factors influencing this determination are presented in Table 4. The assignment of *strong* or *weak* is considered of greater clinical importance than a difference in letter level of quality of evidence. The committee assessed whether the desirable effects of adherence would outweigh the undesirable effects, and the strength of a recommendation reflects the group's degree of confidence in that assessment. Thus, a strong recommendation in favor of an intervention reflects the panel's opinion that the desirable effects of adherence to a recommendation (beneficial health outcomes; lesser burden on staff and patients; and cost savings) will clearly outweigh the undesirable effects (harm to health; more burden on staff and patients; and greater costs). The potential drawbacks of making strong recommendations in the presence of low-quality evidence were taken into account. A weak recommendation in favor of an intervention indicates the judgment that the desirable effects of adherence to a recommendation probably will outweigh the undesirable effects, but the panel is not confident about these tradeoffs—either because some of the evidence is low quality (and thus uncertainty remains regarding the benefits and risks) or the

**TABLE 1. Diagnostic Criteria for Sepsis**

Infection, documented or suspected, and some of the following:
General variables
Fever ( $> 38.3^{\circ}\text{C}$ )
Hypothermia (core temperature $< 36^{\circ}\text{C}$ )
Heart rate $> 90/\text{min}^{-1}$ or more than two SD above the normal value for age
Tachypnea
Altered mental status
Significant edema or positive fluid balance ( $> 20\text{ mL/kg}$ over 24 hr)
Hyperglycemia (plasma glucose $> 140\text{ mg/dL}$ or $7.7\text{ mmol/L}$ ) in the absence of diabetes
Inflammatory variables
Leukocytosis (WBC count $> 12,000\ \mu\text{L}^{-1}$ )
Leukopenia (WBC count $< 4000\ \mu\text{L}^{-1}$ )
Normal WBC count with greater than 10% immature forms
Plasma C-reactive protein more than two SD above the normal value
Plasma procalcitonin more than two SD above the normal value
Hemodynamic variables
Arterial hypotension (SBP $< 90\text{ mm Hg}$ , MAP $< 70\text{ mm Hg}$ , or an SBP decrease $> 40\text{ mm Hg}$ in adults or less than two SD below normal for age)
Organ dysfunction variables
Arterial hypoxemia ( $\text{PaO}_2/\text{FiO}_2 < 300$ )
Acute oliguria (urine output $< 0.5\text{ mL/kg/hr}$ for at least 2 hrs despite adequate fluid resuscitation)
Creatinine increase $> 0.5\text{ mg/dL}$ or $44.2\ \mu\text{mol/L}$
Coagulation abnormalities (INR $> 1.5$ or aPTT $> 60\text{ s}$ )
Ileus (absent bowel sounds)
Thrombocytopenia (platelet count $< 100,000\ \mu\text{L}^{-1}$ )
Hyperbilirubinemia (plasma total bilirubin $> 4\text{ mg/dL}$ or $70\ \mu\text{mol/L}$ )
Tissue perfusion variables
Hyperlactatemia ( $> 1\text{ mmol/L}$ )
Decreased capillary refill or mottling

WBC = white blood cell; SBP = systolic blood pressure; MAP = mean arterial pressure; INR = international normalized ratio; aPTT = activated partial thromboplastin time.

Diagnostic criteria for sepsis in the pediatric population are signs and symptoms of inflammation plus infection with hyper- or hypothermia (rectal temperature  $> 38.5^{\circ}$  or  $< 35^{\circ}\text{C}$ ), tachycardia (may be absent in hypothermic patients), and at least one of the following indications of altered organ function: altered mental status, hypoxemia, increased serum lactate level, or bounding pulses.

Adapted from Levy MM, Fink MP, Marshall JC, et al: 2001 SCCM/ESICM/ACCP/ATS/SIS International Sepsis Definitions Conference. *Crit Care Med* 2003; 31: 1250–1256.

benefits and downsides are closely balanced. A strong recommendation is worded as “we recommend” and a weak recommendation as “we suggest.”

Throughout the document are a number of statements that either follow graded recommendations or are listed as stand-alone numbered statements followed by “ungraded” in parentheses (UG). In the opinion of the committee, these recommendations were not conducive for the GRADE process.

The implications of calling a recommendation strong are that most well-informed patients would accept that intervention and that most clinicians should use it in most situations. Circumstances may exist in which a strong recommendation cannot or should not be followed for an individual because of that patient’s preferences or clinical characteristics that make the recommendation less applicable. A strong recommendation does not automatically imply standard of care. For example, the strong recommendation

**TABLE 2. Severe Sepsis**

**Severe sepsis definition = sepsis-induced tissue hypoperfusion or organ dysfunction (any of the following thought to be due to the infection)**

Sepsis-induced hypotension

Lactate above upper limits laboratory normal

Urine output < 0.5 mL/kg/hr for more than 2 hrs despite adequate fluid resuscitation

Acute lung injury with  $Pa_{O_2}/F_{iO_2} < 250$  in the absence of pneumonia as infection source

Acute lung injury with  $Pa_{O_2}/F_{iO_2} < 200$  in the presence of pneumonia as infection source

Creatinine > 2.0 mg/dL (176.8  $\mu$ mol/L)

Bilirubin > 2 mg/dL (34.2  $\mu$ mol/L)

Platelet count < 100,000  $\mu$ L

Coagulopathy (international normalized ratio > 1.5)

Adapted from Levy MM, Fink MP, Marshall JC, et al: 2001 SCCM/ESICM/ACCP/ATS/SIS International Sepsis Definitions Conference. *Crit Care Med* 2003; 31: 1250–1256.

for administering antibiotics within 1 hr of the diagnosis of severe sepsis, as well as the recommendation for achieving a central venous pressure (CVP) of 8 mm Hg and a central venous oxygen saturation ( $ScvO_2$ ) of 70% in the first 6 hrs of resuscitation of sepsis-induced tissue hypoperfusion, although deemed desirable, are not yet standards of care as verified by practice data.

Significant education of committee members on the GRADE approach built on the process conducted during 2008 efforts. Several members of the committee were trained in the use of GRADEpro software, allowing more formal use of the GRADE system (12). Rules were distributed concerning assessing the body of evidence, and GRADE representatives

were available for advice throughout the process. Subgroups agreed electronically on draft proposals that were then presented for general discussion among subgroup heads, the SSC Steering Committee (two co-chairs, two co-vice chairs, and an at-large committee member), and several selected key committee members who met in July 2011 in Chicago. The results of that discussion were incorporated into the next version of recommendations and again discussed with the whole group using electronic mail. Draft recommendations were distributed to the entire committee and finalized during an additional nominal group meeting in Berlin in October 2011. Deliberations and decisions were then recirculated to the entire committee for approval. At the discretion of the chairs

**TABLE 3. Determination of the Quality of Evidence**

Underlying methodology

A (high) RCTs

B (moderate) Downgraded RCTs or upgraded observational studies

C (low) Well-done observational studies with control RCTs

D (very low) Downgraded controlled studies or expert opinion based on other evidence

Factors that may decrease the strength of evidence

1. Poor quality of planning and implementation of available RCTs, suggesting high likelihood of bias
2. Inconsistency of results, including problems with subgroup analyses
3. Indirectness of evidence (differing population, intervention, control, outcomes, comparison)
4. Imprecision of results
5. High likelihood of reporting bias

Main factors that may increase the strength of evidence

1. Large magnitude of effect (direct evidence, relative risk > 2 with no plausible confounders)
2. Very large magnitude of effect with relative risk > 5 and no threats to validity (by two levels)
3. Dose-response gradient

RCT = randomized controlled trial.



**TABLE 4. Factors Determining Strong vs. Weak Recommendation**

What Should be Considered	Recommended Process
High or moderate evidence ( <i>Is there high or moderate quality evidence?</i> )	The higher the quality of evidence, the more likely a strong recommendation.
Certainty about the balance of benefits vs. harms and burdens ( <i>Is there certainty?</i> )	The larger the difference between the desirable and undesirable consequences and the certainty around that difference, the more likely a strong recommendation. The smaller the net benefit and the lower the certainty for that benefit, the more likely a weak recommendation.
Certainty in or similar values ( <i>Is there certainty or similarity?</i> )	The more certainty or similarity in values and preferences, the more likely a strong recommendation.
Resource implications ( <i>Are resources worth expected benefits?</i> )	The lower the cost of an intervention compared to the alternative and other costs related to the decision—ie, fewer resources consumed—the more likely a strong recommendation.

and following discussion, competing proposals for wording of recommendations or assigning strength of evidence were resolved by formal voting within subgroups and at nominal group meetings. The manuscript was edited for style and form by the writing committee with final approval by subgroup heads and then by the entire committee. To satisfy peer review during the final stages of manuscript approval for publication, several recommendations were edited with approval of the SSC executive committee group head for that recommendation and the EBM lead.

### Conflict of Interest Policy

Since the inception of the SSC guidelines in 2004, no members of the committee represented industry; there was no industry input into guidelines development; and no industry representatives were present at any of the meetings. Industry awareness or comment on the recommendations was not allowed. No member of the guidelines committee received honoraria for any role in the 2004, 2008, or 2012 guidelines process.

A detailed description of the disclosure process and all author disclosures appear in Supplemental Digital Content 1 in the supplemental materials to this document. **Appendix B** shows a flowchart of the COI disclosure process. Committee members who were judged to have either financial or nonfinancial/academic competing interests were recused during the closed discussion session and voting session on that topic. Full disclosure and transparency of all committee members' potential conflicts were sought.

On initial review, 68 financial conflict of interest (COI) disclosures and 54 nonfinancial disclosures were submitted by committee members. Declared COI disclosures from 19 members were determined by the COI subcommittee to be not relevant to the guidelines content process. Nine who were determined to have COI (financial and nonfinancial) were adjudicated by group reassignment and requirement to adhere to SSC COI policy regarding discussion or voting at any committee meetings where content germane to their COI was discussed. Nine were judged as having conflicts that could not be resolved solely by reassignment. One of these individuals was asked to step down from the committee. The other eight were assigned to the groups in which

they had the least COI. They were required to work within their group with full disclosure when a topic for which they had relevant COI was discussed, and they were not allowed to serve as group head. At the time of final approval of the document, an update of the COI statement was required. No additional COI issues were reported that required further adjudication.

## MANAGEMENT OF SEVERE SEPSIS

### Initial Resuscitation and Infection Issues (Table 5)

#### A. Initial Resuscitation

- We recommend the protocolized, quantitative resuscitation of patients with sepsis-induced tissue hypoperfusion (defined in this document as hypotension persisting after initial fluid challenge or blood lactate concentration  $\geq 4$  mmol/L). This protocol should be initiated as soon as hypoperfusion is recognized and should not be delayed pending ICU admission. During the first 6 hrs of resuscitation, the goals of initial resuscitation of sepsis-induced hypoperfusion should include all of the following as a part of a treatment protocol (grade 1C):
  - CVP 8–12 mm Hg
  - MAP  $\geq 65$  mm Hg
  - Urine output  $\geq 0.5$  mL·kg·hr
  - Superior vena cava oxygenation saturation (ScvO<sub>2</sub>) or mixed venous oxygen saturation (SvO<sub>2</sub>) 70% or 65%, respectively.
- We suggest targeting resuscitation to normalize lactate in patients with elevated lactate levels as a marker of tissue hypoperfusion (grade 2C).

**Rationale.** In a randomized, controlled, single-center study, early quantitative resuscitation improved survival for emergency department patients presenting with septic shock (13). Resuscitation targeting the physiologic goals expressed in recommendation 1 (above) for the initial 6-hr period was associated with a 15.9% absolute reduction in 28-day mortality rate. This strategy, termed *early goal-directed therapy*, was evaluated in a multicenter trial of 314 patients with severe sepsis in eight Chinese centers (14). This trial reported a 17.7% absolute reduction in 28-day mortality (survival rates, 75.2% vs. 57.5%,



$p = 0.001$ ). A large number of other observational studies using similar forms of early quantitative resuscitation in comparable patient populations have shown significant mortality reduction compared to the institutions' historical controls (**Supplemental Digital Content 2**, <http://links.lww.com/CCM/A615>). Phase III of the SSC activities, the international performance improvement program, showed that the mortality of septic patients presenting with both hypotension and lactate  $\geq 4$  mmol/L was 46.1%, similar to the 46.6% mortality found in the first trial cited above (15). As part of performance improvement programs, some hospitals have lowered the lactate threshold for triggering quantitative resuscitation in the patient with severe sepsis, but these thresholds have not been subjected to randomized trials.

The consensus panel judged use of CVP and  $SvO_2$  targets to be recommended physiologic targets for resuscitation. Although there are limitations to CVP as a marker of intravascular volume status and response to fluids, a low CVP

generally can be relied upon as supporting positive response to fluid loading. Either intermittent or continuous measurements of oxygen saturation were judged to be acceptable. During the first 6 hrs of resuscitation, if  $ScvO_2$  less than 70% or  $SvO_2$  equivalent of less than 65% persists with what is judged to be adequate intravascular volume repletion in the presence of persisting tissue hypoperfusion, then dobutamine infusion (to a maximum of 20  $\mu\text{g}/\text{kg}/\text{min}$ ) or transfusion of packed red blood cells to achieve a hematocrit of greater than or equal to 30% in attempts to achieve the  $ScvO_2$  or  $SvO_2$  goal are options. The strong recommendation for achieving a CVP of 8 mm Hg and an  $ScvO_2$  of 70% in the first 6 hrs of resuscitation of sepsis-induced tissue hypoperfusion, although deemed desirable, are not yet the standard of care as verified by practice data. The publication of the initial results of the international SSC performance improvement program demonstrated that adherence to CVP and  $ScvO_2$  targets for initial resuscitation was low (15).

**TABLE 5. Recommendations: Initial Resuscitation and Infection Issues**

#### A. Initial Resuscitation

1. Protocolized, quantitative resuscitation of patients with sepsis-induced tissue hypoperfusion (defined in this document as hypotension persisting after initial fluid challenge or blood lactate concentration  $\geq 4$  mmol/L). Goals during the first 6 hrs of resuscitation:
  - a) Central venous pressure 8–12 mm Hg
  - b) Mean arterial pressure (MAP)  $\geq 65$  mm Hg
  - c) Urine output  $\geq 0.5$  mL/kg/hr
  - d) Central venous (superior vena cava) or mixed venous oxygen saturation 70% or 65%, respectively (grade 1C).
2. In patients with elevated lactate levels targeting resuscitation to normalize lactate (grade 2C).

#### B. Screening for Sepsis and Performance Improvement

1. Routine screening of potentially infected seriously ill patients for severe sepsis to allow earlier implementation of therapy (grade 1C).
2. Hospital-based performance improvement efforts in severe sepsis (UG).

#### C. Diagnosis

1. Cultures as clinically appropriate before antimicrobial therapy if no significant delay ( $> 45$  mins) in the start of antimicrobial(s) (grade 1C). At least 2 sets of blood cultures (both aerobic and anaerobic bottles) be obtained before antimicrobial therapy with at least 1 drawn percutaneously and 1 drawn through each vascular access device, unless the device was recently ( $< 48$  hrs) inserted (grade 1C).
2. Use of the 1,3 beta-D-glucan assay (grade 2B), mannan and anti-mannan antibody assays (2C), if available and invasive candidiasis is in differential diagnosis of cause of infection.
3. Imaging studies performed promptly to confirm a potential source of infection (UG).

#### D. Antimicrobial Therapy

1. Administration of effective intravenous antimicrobials within the first hour of recognition of septic shock (grade 1B) and severe sepsis without septic shock (grade 1C) as the goal of therapy.
- 2a. Initial empiric anti-infective therapy of one or more drugs that have activity against all likely pathogens (bacterial and/or fungal or viral) and that penetrate in adequate concentrations into tissues presumed to be the source of sepsis (grade 1B).
- 2b. Antimicrobial regimen should be reassessed daily for potential deescalation (grade 1B).
3. Use of low procalcitonin levels or similar biomarkers to assist the clinician in the discontinuation of empiric antibiotics in patients who initially appeared septic, but have no subsequent evidence of infection (grade 2C).
- 4a. Combination empirical therapy for neutropenic patients with severe sepsis (grade 2B) and for patients with difficult-to-treat, multidrug-resistant bacterial pathogens such as *Acinetobacter* and *Pseudomonas* spp. (grade 2B). For patients with severe infections associated with respiratory failure and septic shock, combination therapy with an extended spectrum beta-lactam and either an aminoglycoside or a fluoroquinolone is for *P. aeruginosa* bacteremia (grade 2B). A combination of beta-lactam and macrolide for patients with septic shock from bacteremic *Streptococcus pneumoniae* infections (grade 2B).

(Continued)

**TABLE 5. (Continued) Recommendations: Initial Resuscitation and Infection Issues**

- 4b. Empiric combination therapy should not be administered for more than 3–5 days. De-escalation to the most appropriate single therapy should be performed as soon as the susceptibility profile is known (grade 2B).
5. Duration of therapy typically 7–10 days; longer courses may be appropriate in patients who have a slow clinical response, undrainable foci of infection, bacteremia with *S. aureus*; some fungal and viral infections or immunologic deficiencies, including neutropenia (grade 2C).
6. Antiviral therapy initiated as early as possible in patients with severe sepsis or septic shock of viral origin (grade 2C).
7. Antimicrobial agents should not be used in patients with severe inflammatory states determined to be of noninfectious cause (UG).

**E. Source Control**

1. A specific anatomical diagnosis of infection requiring consideration for emergent source control be sought and diagnosed or excluded as rapidly as possible, and intervention be undertaken for source control within the first 12 hr after the diagnosis is made, if feasible (grade 1C).
2. When infected peripancreatic necrosis is identified as a potential source of infection, definitive intervention is best delayed until adequate demarcation of viable and nonviable tissues has occurred (grade 2B).
3. When source control in a severely septic patient is required, the effective intervention associated with the least physiologic insult should be used (eg, percutaneous rather than surgical drainage of an abscess) (UG).
4. If intravascular access devices are a possible source of severe sepsis or septic shock, they should be removed promptly after other vascular access has been established (UG).

**F. Infection Prevention**

- 1a. Selective oral decontamination and selective digestive decontamination should be introduced and investigated as a method to reduce the incidence of ventilator-associated pneumonia; This infection control measure can then be instituted in health care settings and regions where this methodology is found to be effective (grade 2B).
- 1b. Oral chlorhexidine gluconate be used as a form of oropharyngeal decontamination to reduce the risk of ventilator-associated pneumonia in ICU patients with severe sepsis (grade 2B).

In mechanically ventilated patients or those with known preexisting decreased ventricular compliance, a higher target CVP of 12 to 15 mm Hg should be achieved to account for the impediment in filling (16). Similar consideration may be warranted in circumstances of increased abdominal pressure (17). Elevated CVP may also be seen with preexisting clinically significant pulmonary artery hypertension, making use of this variable untenable for judging intravascular volume status. Although the cause of tachycardia in septic patients may be multifactorial, a decrease in elevated pulse rate with fluid resuscitation is often a useful marker of improving intravascular filling. Published observational studies have demonstrated an association between good clinical outcome in septic shock and MAP  $\geq$  65 mm Hg as well as ScvO<sub>2</sub>  $\geq$  70% (measured in the superior vena cava, either intermittently or continuously [18]). Many studies support the value of early protocolized resuscitation in severe sepsis and sepsis-induced tissue hypoperfusion (19–24). Studies of patients with shock indicate that SvO<sub>2</sub> runs 5% to 7% lower than ScvO<sub>2</sub> (25). While the committee recognized the controversy surrounding resuscitation targets, an early quantitative resuscitation protocol using CVP and venous blood gases can be readily established in both emergency department and ICU settings (26). Recognized limitations to static ventricular filling pressure estimates exist as surrogates for fluid resuscitation (27, 28), but measurement of CVP is currently the most readily obtainable target for fluid resuscitation. Targeting dynamic measures of

fluid responsiveness during resuscitation, including flow and possibly volumetric indices and microcirculatory changes, may have advantages (29–32). Available technologies allow measurement of flow at the bedside (33, 34); however, the efficacy of these monitoring techniques to influence clinical outcomes from early sepsis resuscitation remains incomplete and requires further study before endorsement.

The global prevalence of severe sepsis patients initially presenting with either hypotension with lactate  $\geq$  4 mmol/L, hypotension alone, or lactate  $\geq$  4 mmol/L alone, is reported as 16.6%, 49.5%, and 5.4%, respectively (15). The mortality rate is high in septic patients with both hypotension and lactate  $\geq$  4 mmol/L (46.1%) (15), and is also increased in severely septic patients with hypotension alone (36.7%) and lactate  $\geq$  4 mmol/L alone (30%) (15). If ScvO<sub>2</sub> is not available, lactate normalization may be a feasible option in the patient with severe sepsis-induced tissue hypoperfusion. ScvO<sub>2</sub> and lactate normalization may also be used as a combined endpoint when both are available. Two multicenter randomized trials evaluated a resuscitation strategy that included lactate reduction as a single target or a target combined with ScvO<sub>2</sub> normalization (35, 36). The first trial reported that early quantitative resuscitation based on lactate clearance (decrease by at least 10%) was noninferior to early quantitative resuscitation based on achieving ScvO<sub>2</sub> of 70% or more (35). The intention-to-treat group contained 300, but the number of patients actually requiring either ScvO<sub>2</sub> normalization or lactate clearance was small ( $n = 30$ ). The second trial included

348 patients with lactate levels  $\geq 3$  mmol/L (36). The strategy in this trial was based on a greater than or equal to 20% decrease in lactate levels per 2 hrs of the first 8 hrs in addition to ScvO<sub>2</sub> target achievement, and was associated with a 9.6% absolute reduction in mortality ( $p = 0.067$ ; adjusted hazard ratio, 0.61; 95% CI, 0.43–0.87;  $p = 0.006$ ).

## B. Screening for Sepsis and Performance Improvement

1. We recommend routine screening of potentially infected seriously ill patients for severe sepsis to increase the early identification of sepsis and allow implementation of early sepsis therapy (grade 1C).

**Rationale.** The early identification of sepsis and implementation of early evidence-based therapies have been documented to improve outcomes and decrease sepsis-related mortality (15). Reducing the time to diagnosis of severe sepsis is thought to be a critical component of reducing mortality from sepsis-related multiple organ dysfunction (35). Lack of early recognition is a major obstacle to sepsis bundle initiation. Sepsis screening tools have been developed to monitor ICU patients (37–41), and their implementation has been associated with decreased sepsis-related mortality (15).

2. Performance improvement efforts in severe sepsis should be used to improve patient outcomes (UG).

**Rationale.** Performance improvement efforts in sepsis have been associated with improved patient outcomes (19, 42–46). Improvement in care through increasing compliance with sepsis quality indicators is the goal of a severe sepsis performance improvement program (47). Sepsis management requires a multidisciplinary team (physicians, nurses, pharmacy, respiratory, dieticians, and administration) and multispecialty collaboration (medicine, surgery, and emergency medicine) to maximize the chance for success. Evaluation of process change requires consistent education, protocol development and implementation, data collection, measurement of indicators, and feedback to facilitate the continuous performance improvement. Ongoing educational sessions provide feedback on indicator compliance and can help identify areas for additional improvement efforts. In addition to traditional continuing medical education efforts to introduce guidelines into clinical practice, knowledge translation efforts have recently been introduced as a means to promote the use of high-quality evidence in changing behavior (48). Protocol implementation associated with education and performance feedback has been shown to change clinician behavior and is associated with improved outcomes and cost-effectiveness in severe sepsis (19, 23, 24, 49). In partnership with the Institute for Healthcare Improvement, phase III of the Surviving Sepsis Campaign targeted the implementation of a core set (“bundle”) of recommendations in hospital environments where change in behavior and clinical impact were measured (50). The SSC guidelines and bundles can be used as the basis of a sepsis performance improvement program.

Application of the SSC sepsis bundles led to sustained, continuous quality improvement in sepsis care and was associated with reduced mortality (15). Analysis of the data from nearly

32,000 patient charts gathered from 239 hospitals in 17 countries through September 2011 as part of phase III of the campaign informed the revision of the bundles in conjunction with the 2012 guidelines. As a result, for the 2012 version, the management bundle was dropped and the resuscitation bundle was broken into two parts and modified as shown in **Figure 1**. For performance improvement quality indicators, resuscitation target thresholds are not considered. However, recommended targets from the guidelines are included with the bundles for reference purposes.

## C. Diagnosis

1. We recommend obtaining appropriate cultures before antimicrobial therapy is initiated if such cultures do not cause significant delay ( $> 45$  minutes) in the start of antimicrobial(s) administration (grade 1C). To optimize identification of causative organisms, we recommend obtaining at least two sets of blood cultures (both aerobic and anaerobic bottles) before antimicrobial therapy, with at least one drawn percutaneously and one drawn through each vascular access device, unless the device was recently ( $< 48$  hours) inserted. These blood cultures can be drawn at the same time if they are obtained from different sites. Cultures of other sites (preferably quantitative where appropriate), such as urine, cerebrospinal fluid, wounds, respiratory secretions, or other body fluids that may be the source of infection, should also be obtained before antimicrobial therapy if doing so does not cause significant delay in antibiotic administration (grade 1C).

**Rationale.** Although sampling should not delay timely administration of antimicrobial agents in patients with severe sepsis (eg, lumbar puncture in suspected meningitis), obtaining appropriate cultures before administration of antimicrobials is essential to confirm infection and the responsible pathogens, and to allow de-escalation of antimicrobial therapy after receipt of the susceptibility profile. Samples can be refrigerated or frozen if processing cannot be performed immediately. Because rapid sterilization of blood cultures can occur within a few hours after the first antimicrobial dose, obtaining those cultures before therapy is essential if the causative organism is to be identified. Two or more blood cultures are recommended (51). In patients with indwelling catheters (for more than 48 hrs), at least one blood culture should be drawn through each lumen of each vascular access device (if feasible, especially for vascular devices with signs of inflammation, catheter dysfunction, or indicators of thrombus formation). Obtaining blood cultures peripherally and through a vascular access device is an important strategy. If the same organism is recovered from both cultures, the likelihood that the organism is causing the severe sepsis is enhanced.

In addition, if equivalent volumes of blood drawn for culture and the vascular access device is positive much earlier than the peripheral blood culture (ie, more than 2 hrs earlier), the data support the concept that the vascular access device is the source of the infection (36, 51, 52). Quantitative cultures of catheter and peripheral blood may also be useful for determining whether the catheter is the source of infection. The volume of blood drawn with the culture tube should be  $\geq 10$  mL (53).

## SURVIVING SEPSIS CAMPAIGN BUNDLES

### TO BE COMPLETED WITHIN 3 HOURS:

- 1) Measure lactate level
- 2) Obtain blood cultures prior to administration of antibiotics
- 3) Administer broad spectrum antibiotics
- 4) Administer 30 mL/kg crystalloid for hypotension or lactate  $\geq 4$  mmol/L

### TO BE COMPLETED WITHIN 6 HOURS:

- 5) Apply vasopressors (for hypotension that does not respond to initial fluid resuscitation) to maintain a mean arterial pressure (MAP)  $\geq 65$  mm Hg
- 6) In the event of persistent arterial hypotension despite volume resuscitation (septic shock) or initial lactate  $\geq 4$  mmol/L (36 mg/dL):
  - Measure central venous pressure (CVP)\*
  - Measure central venous oxygen saturation (ScvO<sub>2</sub>)\*
- 7) Remeasure lactate if initial lactate was elevated\*

\*Targets for quantitative resuscitation included in the guidelines are CVP of  $\geq 8$  mm Hg, ScvO<sub>2</sub> of  $\geq 70\%$ , and normalization of lactate.

**Figure 1.** Surviving Sepsis Campaign Care Bundles.

Quantitative (or semiquantitative) cultures of respiratory tract secretions are often recommended for the diagnosis of ventilator-associated pneumonia (54), but their diagnostic value remains unclear (55).

The Gram stain can be useful, in particular for respiratory tract specimens, to determine if inflammatory cells are present (greater than five polymorphonuclear leukocytes/high-powered field and less than ten squamous cells/low-powered field) and if culture results will be informative of lower respiratory pathogens. Rapid influenza antigen testing during periods of increased influenza activity in the community is also recommended. A focused history can provide vital information about potential risk factors for infection and likely pathogens at specific tissue sites. The potential role of biomarkers for diagnosis of infection in patients presenting with severe sepsis remains undefined. The utility of procalcitonin levels or other biomarkers (such as C-reactive protein) to discriminate the acute inflammatory pattern of sepsis from other causes of generalized inflammation (eg, postoperative, other forms of shock) has not been demonstrated. No recommendation can be given for the use of these markers to distinguish between severe infection and other acute inflammatory states (56–58).

In the near future, rapid, non-culture-based diagnostic methods (polymerase chain reaction, mass spectroscopy, microarrays) might be helpful for a quicker identification of pathogens and major antimicrobial resistance determinants (59). These methodologies could be particularly useful for difficult-to-culture pathogens or in clinical situations where empiric antimicrobial agents have been administered before culture samples were obtained. Clinical experience remains limited, and more clinical studies are needed before recommending these non-culture molecular methods as a replacement for standard blood culture methods (60, 61).

2. We suggest the use of the 1,3  $\beta$ -D-glucan assay (grade 2B), mannan and anti-mannan antibody assays (grade 2C) when invasive candidiasis is in the differential diagnosis of infection.

**Rationale.** The diagnosis of systemic fungal infection (usually candidiasis) in the critically ill patient can be challenging, and rapid diagnostic methodologies, such as antigen and antibody detection assays, can be helpful in detecting candidiasis in the ICU patient. These suggested tests have shown positive results significantly earlier than standard culture methods (62–67), but false-positive reactions can occur with colonization alone, and their diagnostic utility in managing fungal infection in the ICU needs additional study (65).

3. We recommend that imaging studies be performed promptly in attempts to confirm a potential source of infection. Potential sources of infection should be sampled as they are identified and in consideration of patient risk for transport and invasive procedures (eg, careful coordination and aggressive monitoring if the decision is made to transport for a CT-guided needle aspiration). Bedside studies, such as ultrasound, may avoid patient transport (UG).

**Rationale.** Diagnostic studies may identify a source of infection that requires removal of a foreign body or drainage to maximize the likelihood of a satisfactory response to therapy. Even in the most organized and well-staffed healthcare facilities, however, transport of patients can be dangerous, as can be placing patients in outside-unit imaging devices that are difficult to access and monitor. Balancing risk and benefit is therefore mandatory in those settings.

## D. Antimicrobial Therapy

1. The administration of effective intravenous antimicrobials within the first hour of recognition of septic shock (grade 1B) and severe sepsis without septic shock (grade 1C) should be the goal of therapy. **Remark:** Although the weight of the evidence supports prompt administration of antibiotics following the recognition of severe sepsis and septic shock, the feasibility with which clinicians may achieve this ideal state has not been scientifically evaluated.

**Rationale.** Establishing vascular access and initiating aggressive fluid resuscitation are the first priorities when managing patients with severe sepsis or septic shock. Prompt infusion of antimicrobial agents should also be a priority and may require additional vascular access ports (68, 69). In the presence of septic shock, each hour delay in achieving administration of effective antibiotics is associated with a measurable increase in mortality in a number of studies (15, 68, 70–72). Overall, the preponderance of data support giving antibiotics as soon as possible in patients with severe sepsis with or without septic shock (15, 68, 70–77). The administration of



antimicrobial agents with a spectrum of activity likely to treat the responsible pathogen(s) effectively within 1 hr of the diagnosis of severe sepsis and septic shock. Practical considerations, for example challenges with clinicians' early identification of patients or operational complexities in the drug delivery chain, represent unstudied variables that may impact achieving this goal. Future trials should endeavor to provide an evidence base in this regard. This should be the target goal when managing patients with septic shock, whether they are located within the hospital ward, the emergency department, or the ICU. The strong recommendation for administering antibiotics within 1 hr of the diagnosis of severe sepsis and septic shock, although judged to be desirable, is not yet the standard of care as verified by published practice data (15).

If antimicrobial agents cannot be mixed and delivered promptly from the pharmacy, establishing a supply of premixed antibiotics for such urgent situations is an appropriate strategy for ensuring prompt administration. Many antibiotics will not remain stable if premixed in a solution. This risk must be taken into consideration in institutions that rely on premixed solutions for rapid availability of antibiotics. In choosing the antimicrobial regimen, clinicians should be aware that some antimicrobial agents have the advantage of bolus administration, while others require a lengthy infusion. Thus, if vascular access is limited and many different agents must be infused, bolus drugs may offer an advantage.

2a. We recommend that initial empiric anti-infective therapy include one or more drugs that have activity against all likely pathogens (bacterial and/or fungal or viral) and that penetrate in adequate concentrations into the tissues presumed to be the source of sepsis (grade 1B).

**Rationale.** The choice of empirical antimicrobial therapy depends on complex issues related to the patient's history, including drug intolerances, recent receipt of antibiotics (previous 3 months), underlying disease, the clinical syndrome, and susceptibility patterns of pathogens in the community and hospital, and that previously have been documented to colonize or infect the patient. The most common pathogens that cause septic shock in hospitalized patients are Gram-positive bacteria, followed by Gram-negative and mixed bacterial microorganisms. Candidiasis, toxic shock syndromes, and an array of uncommon pathogens should be considered in selected patients. An especially wide range of potential pathogens exists for neutropenic patients. Recently used anti-infective agents should generally be avoided. When choosing empirical therapy, clinicians should be cognizant of the virulence and growing prevalence of oxacillin (methicillin)-resistant *Staphylococcus aureus*, and resistance to broad-spectrum beta-lactams and carbapenem among Gram-negative bacilli in some communities and healthcare settings. Within regions in which the prevalence of such drug-resistant organisms is significant, empiric therapy adequate to cover these pathogens is warranted.

Clinicians should also consider whether candidemia is a likely pathogen when choosing initial therapy. When deemed warranted, the selection of empirical antifungal therapy (eg, an echinocandin, triazoles such as fluconazole, or a formulation

of amphotericin B) should be tailored to the local pattern of the most prevalent *Candida* species and any recent exposure to antifungal drugs (78). Recent Infectious Diseases Society of America (IDSA) guidelines recommend either fluconazole or an echinocandin. Empiric use of an echinocandin is preferred in most patients with severe illness, especially in those patients who have recently been treated with antifungal agents, or if *Candida glabrata* infection is suspected from earlier culture data. Knowledge of local resistance patterns to antifungal agents should guide drug selection until fungal susceptibility test results, if available, are performed. Risk factors for candidemia, such as immunosuppressed or neutropenic state, prior intense antibiotic therapy, or colonization in multiple sites, should also be considered when choosing initial therapy.

Because patients with severe sepsis or septic shock have little margin for error in the choice of therapy, the initial selection of antimicrobial therapy should be broad enough to cover all likely pathogens. Antibiotic choices should be guided by local prevalence patterns of bacterial pathogens and susceptibility data. Ample evidence exists that failure to initiate appropriate therapy (ie, therapy with activity against the pathogen that is subsequently identified as the causative agent) correlates with increased morbidity and mortality in patients with severe sepsis or septic shock (68, 71, 79, 80). Recent exposure to antimicrobials (within last 3 months) should be considered in the choice of an empiric antibacterial regimen. Patients with severe sepsis or septic shock warrant broad-spectrum therapy until the causative organism and its antimicrobial susceptibilities are defined. Although a global restriction of antibiotics is an important strategy to reduce the development of antimicrobial resistance and to reduce cost, it is not an appropriate strategy in the initial therapy for this patient population. However, as soon as the causative pathogen has been identified, de-escalation should be performed by selecting the most appropriate antimicrobial agent that covers the pathogen and is safe and cost-effective. Collaboration with antimicrobial stewardship programs, where they exist, is encouraged to ensure appropriate choices and rapid availability of effective antimicrobials for treating septic patients. All patients should receive a full loading dose of each agent. Patients with sepsis often have abnormal and vacillating renal or hepatic function, or may have abnormally high volumes of distribution due to aggressive fluid resuscitation, requiring dose adjustment. Drug serum concentration monitoring can be useful in an ICU setting for those drugs that can be measured promptly. Significant expertise is required to ensure that serum concentrations maximize efficacy and minimize toxicity (81, 82).

2b. The antimicrobial regimen should be reassessed daily for potential de-escalation to prevent the development of resistance, to reduce toxicity, and to reduce costs (grade 1B).

**Rationale.** Once the causative pathogen has been identified, the most appropriate antimicrobial agent that covers the pathogen and is safe and cost-effective should be selected. On occasion, continued use of specific combinations of antimicrobials might be indicated even after susceptibility testing is available

(eg, *Pseudomonas* spp. only susceptible to aminoglycosides; enterococcal endocarditis; *Acinetobacter* spp. infections susceptible only to polymyxins). Decisions on definitive antibiotic choices should be based on the type of pathogen, patient characteristics, and favored hospital treatment regimens.

Narrowing the spectrum of antimicrobial coverage and reducing the duration of antimicrobial therapy will reduce the likelihood that the patient will develop superinfection with other pathogenic or resistant organisms, such as *Candida* species, *Clostridium difficile*, or vancomycin-resistant *Enterococcus faecium*. However, the desire to minimize superinfections and other complications should not take precedence over giving an adequate course of therapy to cure the infection that caused the severe sepsis or septic shock.

3. We suggest the use of low procalcitonin levels or similar biomarkers to assist the clinician in the discontinuation of empiric antibiotics in patients who appeared septic, but have no subsequent evidence of infection (grade 2C).

**Rationale.** This suggestion is predicated on the preponderance of the published literature relating to the use of procalcitonin as a tool to discontinue unnecessary antimicrobials (58, 83). However, clinical experience with this strategy is limited and the potential for harm remains a concern (83). No evidence demonstrates that this practice reduces the prevalence of antimicrobial resistance or the risk of antibiotic-related diarrhea from *C. difficile*. One recent study failed to show any benefit of daily procalcitonin measurement in early antibiotic therapy or survival (84).

- 4a. Empiric therapy should attempt to provide antimicrobial activity against the most likely pathogens based upon each patient's presenting illness and local patterns of infection. We suggest combination empiric therapy for neutropenic patients with severe sepsis (grade 2B) and for patients with difficult-to-treat, multidrug-resistant bacterial pathogens such as *Acinetobacter* and *Pseudomonas* spp. (grade 2B). For selected patients with severe infections associated with respiratory failure and septic shock, combination therapy with an extended spectrum beta-lactam and either an aminoglycoside or a fluoroquinolone is suggested for *P. aeruginosa* bacteremia (grade 2B). Similarly, a more complex combination of beta-lactam and a macrolide is suggested for patients with septic shock from bacteremic *Streptococcus pneumoniae* infections (grade 2B).

**Rationale.** Complex combinations might be needed in settings where highly antibiotic-resistant pathogens are prevalent, with such regimens incorporating carbapenems, colistin, rifampin, or other agents. However, a recent controlled trial suggested that adding a fluoroquinolone to a carbapenem as empiric therapy did not improve outcome in a population at low risk for infection with resistant microorganisms (85).

- 4b. We suggest that combination therapy, when used empirically in patients with severe sepsis, should not be administered for longer than 3 to 5 days. De-escalation to the most appropriate single-agent therapy should be performed as soon as the susceptibility profile is known (grade 2B). Exceptions

would include aminoglycoside monotherapy, which should be generally avoided, particularly for *P. aeruginosa* sepsis, and for selected forms of endocarditis, where prolonged courses of combinations of antibiotics are warranted.

**Rationale.** A propensity-matched analysis, meta-analysis, and meta-regression analysis, along with additional observational studies, have demonstrated that combination therapy produces a superior clinical outcome in severely ill, septic patients with a high risk of death (86–90). In light of the increasing frequency of resistance to antimicrobial agents in many parts of the world, broad-spectrum coverage generally requires the initial use of combinations of antimicrobial agents. Combination therapy used in this context connotes at least two different classes of antibiotics (usually a beta-lactam agent with a macrolide, fluoroquinolone, or aminoglycoside for select patients). A controlled trial suggested, however, that when using a carbapenem as empiric therapy in a population at low risk for infection with resistant microorganisms, the addition of a fluoroquinolone does not improve outcomes of patients (85). A number of other recent observational studies and some small, prospective trials support initial combination therapy for selected patients with specific pathogens (eg, pneumococcal sepsis, multidrug-resistant Gram-negative pathogens) (91–93), but evidence from adequately powered, randomized clinical trials is not available to support combination over monotherapy other than in septic patients at high risk of death. In some clinical scenarios, combination therapies are biologically plausible and are likely clinically useful even if evidence has not demonstrated improved clinical outcome (89, 90, 94, 95). Combination therapy for suspected or known *Pseudomonas aeruginosa* or other multidrug-resistant Gram-negative pathogens, pending susceptibility results, increases the likelihood that at least one drug is effective against that strain and positively affects outcome (88, 96).

5. We suggest that the duration of therapy typically be 7 to 10 days if clinically indicated; longer courses may be appropriate in patients who have a slow clinical response, undrainable foci of infection, bacteremia with *S. aureus*; some fungal and viral infections, or immunologic deficiencies, including neutropenia (grade 2C).

**Rationale.** Although patient factors may influence the length of antibiotic therapy, in general, a duration of 7–10 days (in the absence of source control issues) is adequate. Thus, decisions to continue, narrow, or stop antimicrobial therapy must be made on the basis of clinician judgment and clinical information. Clinicians should be cognizant of blood cultures being negative in a significant percentage of cases of severe sepsis or septic shock, despite the fact that many of these cases are very likely caused by bacteria or fungi. Clinicians should be cognizant that blood cultures will be negative in a significant percentage of cases of severe sepsis or septic shock, despite many of these cases are very likely caused by bacteria or fungi.

6. We suggest that antiviral therapy be initiated as early as possible in patients with severe sepsis or septic shock of viral origin (grade 2C).

**Rationale.** Recommendations for antiviral treatment include the use of: a) early antiviral treatment of suspected or confirmed influenza among persons with severe influenza (eg, those who have severe, complicated, or progressive illness or who require hospitalization); b) early antiviral treatment of suspected or confirmed influenza among persons at higher risk for influenza complications; and c) therapy with a neuraminidase inhibitor (oseltamivir or zanamivir) for persons with influenza caused by 2009 H1N1 virus, influenza A (H3N2) virus, or influenza B virus, or when the influenza virus type or influenza A virus subtype is unknown (97, 98). Susceptibility to antivirals is highly variable in a rapidly evolving virus such as influenza, and therapeutic decisions must be guided by updated information regarding the most active, strain-specific, antiviral agents during influenza epidemics (99, 100).

The role of cytomegalovirus (CMV) and other herpesviruses as significant pathogens in septic patients, especially those not known to be severely immunocompromised, remains unclear. Active CMV viremia is common (15%–35%) in critically ill patients; the presence of CMV in the bloodstream has been repeatedly found to be a poor prognostic indicator (101, 102). What is not known is whether CMV simply is a marker of disease severity or if the virus actually contributes to organ injury and death in septic patients (103). No treatment recommendations can be given based on the current level of evidence. In those patients with severe primary or generalized varicella-zoster virus infections, and in rare patients with disseminated herpes simplex infections, antiviral agents such as acyclovir can be highly effective when initiated early in the course of infection (104).

7. We recommend that antimicrobial agents not be used in patients with severe inflammatory states determined to be of noninfectious cause (UG).

**Rationale.** When infection is found not to be present, antimicrobial therapy should be stopped promptly to minimize the likelihood that the patient will become infected with an antimicrobial-resistant pathogen or will develop a drug-related adverse effect. Although it is important to stop unnecessary antibiotics early, clinicians should be cognizant that blood cultures will be negative in more than 50% of cases of severe sepsis or septic shock if the patients are receiving empiric antimicrobial therapy; yet many of these cases are very likely caused by bacteria or fungi. Thus, the decisions to continue, narrow, or stop antimicrobial therapy must be made on the basis of clinician judgment and clinical information.

## E. Source Control

1. We recommend that a specific anatomical diagnosis of infection requiring consideration for emergent source control (eg, necrotizing soft tissue infection, peritonitis, cholangitis, intestinal infarction) be sought and diagnosed or

excluded as rapidly as possible, and intervention be undertaken for source control within the first 12 hr after the diagnosis is made, if feasible (grade 1C).

2. We suggest that when infected peripancreatic necrosis is identified as a potential source of infection, definitive intervention is best delayed until adequate demarcation of viable and nonviable tissues has occurred (grade 2B).
3. When source control in a severely septic patient is required, the effective intervention associated with the least physiologic insult should be used (eg, percutaneous rather than surgical drainage of an abscess) (UG).
4. If intravascular access devices are a possible source of severe sepsis or septic shock, they should be removed promptly after other vascular access has been established (UG).

**Rationale.** The principles of source control in the management of sepsis include a rapid diagnosis of the specific site of infection and identification of a focus of infection amenable to source control measures (specifically the drainage of an abscess, debridement of infected necrotic tissue, removal of a potentially infected device, and definitive control of a source of ongoing microbial contamination) (105). Foci of infection readily amenable to source control measures include an intra-abdominal abscess or gastrointestinal perforation, cholangitis or pyelonephritis, intestinal ischemia or necrotizing soft tissue infection, and other deep space infection, such as an empyema or septic arthritis. Such infectious foci should be controlled as soon as possible following successful initial resuscitation (106–108), and intravascular access devices that are potentially the source of severe sepsis or septic shock should be removed promptly after establishing other sites for vascular access (109, 110).

A randomized, controlled trial (RCT) comparing early to delayed surgical intervention for peripancreatic necrosis showed better outcomes with a delayed approach (111). Moreover, a randomized surgical study found that a minimally invasive, step-up approach was better tolerated by patients and had a lower mortality than open necrosectomy in necrotizing pancreatitis (112), although areas of uncertainty exist, such as definitive documentation of infection and appropriate length of delay. The selection of optimal source control methods must weigh the benefits and risks of the specific intervention as well as risks of transfer (113). Source control interventions may cause further complications, such as bleeding, fistulas, or inadvertent organ injury. Surgical intervention should be considered when other interventional approaches are inadequate or when diagnostic uncertainty persists despite radiologic evaluation. Specific clinical situations require consideration of available choices, the patient's preferences, and the clinician's expertise.

## F. Infection Prevention

- 1a. We suggest that selective oral decontamination (SOD) and selective digestive decontamination (SDD) should be introduced and investigated as a method to reduce the



incidence of ventilator-associated pneumonia (VAP); this infection control measure can then be instituted in health-care settings and regions where this methodology is found to be effective (grade 2B).

- 1b. We suggest oral chlorhexidine gluconate (CHG) be used as a form of oropharyngeal decontamination to reduce the risk of VAP in ICU patients with severe sepsis (grade 2B).

**Rationale.** Careful infection control practices (eg, hand washing, expert nursing care, catheter care, barrier precautions, airway management, elevation of the head of the bed, subglottic suctioning) should be instituted during the care of septic patients as reviewed in the nursing considerations for the Surviving Sepsis Campaign (114). The role of SDD with systemic antimicrobial prophylaxis and its variants (eg, SOD, CHG) has been a contentious issue ever since the concept was first developed more than 30 years ago. The notion of limiting the acquisition of opportunistic, often multidrug-resistant, healthcare-associated microorganisms has its appeal by promoting “colonization resistance” from the resident microbiome existing along mucosal surfaces of the alimentary tract. However, the efficacy of SDD, its safety, propensity to prevent or promote antibiotic resistance, and cost-effectiveness remain debatable despite a number of favorable meta-analyses and controlled clinical trials (115). The data indicate an overall reduction in VAP but no consistent improvement in mortality, except in selected populations in some studies. Most studies do not specifically address the efficacy of SDD in patients who present with sepsis, but some do (116–118).

Oral CHG is relatively easy to administer, decreases risk of nosocomial infection, and reduces the potential concern over promotion of antimicrobial resistance by SDD regimens. This remains a subject of considerable debate, despite the recent evidence that the incidence of antimicrobial resistance does not change appreciably with current SDD regimens (119–121). The grade 2B was designated for both SOD and CHG as it was felt that risk was lower with CHG and the measure better accepted despite less published literature than with SOD.

**Supplemental Digital Content 3** (<http://links.lww.com/CCM/A615>) shows a GRADEpro Summary of Evidence Table for the use of topical digestive tract antibiotics and CHG for prophylaxis against VAP.

## Hemodynamic Support and Adjunctive Therapy (Table 6)

### G. Fluid Therapy of Severe Sepsis

1. We recommend crystalloids be used as the initial fluid of choice in the resuscitation of severe sepsis and septic shock (grade 1B).
2. We recommend against the use of hydroxyethyl starches (HES) for fluid resuscitation of severe sepsis and septic shock (grade 1B). (This recommendation is based on the results of the VISEP [128], CRYSTMAS [122], 6S [123], and CHEST [124] trials. The results of the recently completed CRYSTAL trial were not considered.)

3. We suggest the use of albumin in the fluid resuscitation of severe sepsis and septic shock when patients require substantial amounts of crystalloids (grade 2C).

**Rationale.** The absence of any clear benefit following the administration of colloid solutions compared to crystalloid solutions, together with the expense associated with colloid solutions, supports a high-grade recommendation for the use of crystalloid solutions in the initial resuscitation of patients with severe sepsis and septic shock.

Three recent multicenter RCTs evaluating 6% HES 130/0.4 solutions (tetra starches) have been published. The CRYSTMAS study demonstrated no difference in mortality with HES vs. 0.9% normal saline (31% vs. 25.3%,  $p = 0.37$ ) in the resuscitation of septic shock patients; however the study was underpowered to detect the 6% difference in absolute mortality observed (122). In a sicker patient cohort, a Scandinavian multicenter study in septic patients (6S Trial Group) showed increased mortality rates with 6% HES 130/0.42 fluid resuscitation compared to Ringer’s acetate (51% vs. 43%  $p = 0.03$ ) (123). The CHEST study, conducted in a heterogeneous population of patients admitted to intensive care (HES vs. isotonic saline,  $n = 7000$  critically ill patients), showed no difference in 90-day mortality between resuscitation with 6% HES with a molecular weight of 130 kD/0.40 and isotonic saline (18% vs. 17%,  $p = 0.26$ ); the need for renal replacement therapy was higher in the HES group (7.0% vs. 5.8%; relative risk [RR], 1.21; 95% confidence interval [CI], 1.00–1.45;  $p = 0.04$ ) (124). A meta-analysis of 56 randomized trials found no overall difference in mortality between crystalloids and artificial colloids (modified gelatins, HES, dextran) when used for initial fluid resuscitation (125). Information from 3 randomized trials ( $n = 704$  patients with severe sepsis/septic shock) did not show survival benefit with use of heta-, hexa-, or pentastarches compared to other fluids (RR, 1.15; 95% CI, 0.95–1.39; random effect;  $I^2 = 0\%$ ) (126–128). However, these solutions increased the risk of acute kidney injury (RR, 1.60; 95% CI, 1.26–2.04;  $I^2 = 0\%$ ) (126–128). The evidence of harm observed in the 6S and CHEST studies and the meta-analysis supports a high-level recommendation advising against the use of HES solutions in patients with severe sepsis and septic shock, particularly since other options for fluid resuscitation exist. The CRYSTAL trial, another large prospective clinical trial comparing crystalloids and colloids, was recently completed and will provide additional insight into HES fluid resuscitation.

The SAFE study indicated that albumin administration was safe and equally as effective as 0.9% saline (129). A meta-analysis aggregated data from 17 randomized trials ( $n = 1977$ ) of albumin vs. other fluid solutions in patients with severe sepsis/septic shock (130); 279 deaths occurred among 961 albumin-treated patients vs. 343 deaths among 1,016 patients treated with other fluids, thus favoring albumin (odds ratio [OR], 0.82; 95% CI, 0.67–1.00;  $I^2 = 0\%$ ). When albumin-treated patients were compared



**TABLE 6. Recommendations: Hemodynamic Support and Adjunctive Therapy****G. Fluid Therapy of Severe Sepsis**

1. Crystalloids as the initial fluid of choice in the resuscitation of severe sepsis and septic shock (grade 1B).
2. Against the use of hydroxyethyl starches for fluid resuscitation of severe sepsis and septic shock (grade 1B).
3. Albumin in the fluid resuscitation of severe sepsis and septic shock when patients require substantial amounts of crystalloids (grade 2C).
4. Initial fluid challenge in patients with sepsis-induced tissue hypoperfusion with suspicion of hypovolemia to achieve a minimum of 30 mL/kg of crystalloids (a portion of this may be albumin equivalent). More rapid administration and greater amounts of fluid may be needed in some patients (grade 1C).
5. Fluid challenge technique be applied wherein fluid administration is continued as long as there is hemodynamic improvement either based on dynamic (eg, change in pulse pressure, stroke volume variation) or static (eg, arterial pressure, heart rate) variables (UG).

**H. Vasopressors**

1. Vasopressor therapy initially to target a mean arterial pressure (MAP) of 65 mm Hg (grade 1C).
2. Norepinephrine as the first choice vasopressor (grade 1B).
3. Epinephrine (added to and potentially substituted for norepinephrine) when an additional agent is needed to maintain adequate blood pressure (grade 2B).
4. Vasopressin 0.03 units/minute can be added to norepinephrine (NE) with intent of either raising MAP or decreasing NE dosage (UG).
5. Low dose vasopressin is not recommended as the single initial vasopressor for treatment of sepsis-induced hypotension and vasopressin doses higher than 0.03-0.04 units/minute should be reserved for salvage therapy (failure to achieve adequate MAP with other vasopressor agents) (UG).
6. Dopamine as an alternative vasopressor agent to norepinephrine only in highly selected patients (eg, patients with low risk of tachyarrhythmias and absolute or relative bradycardia) (grade 2C).
7. Phenylephrine is not recommended in the treatment of septic shock except in circumstances where (a) norepinephrine is associated with serious arrhythmias, (b) cardiac output is known to be high and blood pressure persistently low or (c) as salvage therapy when combined inotrope/vasopressor drugs and low dose vasopressin have failed to achieve MAP target (grade 1C).
8. Low-dose dopamine should not be used for renal protection (grade 1A).
9. All patients requiring vasopressors have an arterial catheter placed as soon as practical if resources are available (UG).

**I. Inotropic Therapy**

1. A trial of dobutamine infusion up to 20 micrograms/kg/min be administered or added to vasopressor (if in use) in the presence of (a) myocardial dysfunction as suggested by elevated cardiac filling pressures and low cardiac output, or (b) ongoing signs of hypoperfusion, despite achieving adequate intravascular volume and adequate MAP (grade 1C).
2. Not using a strategy to increase cardiac index to predetermined supranormal levels (grade 1B).

**J. Corticosteroids**

1. Not using intravenous hydrocortisone to treat adult septic shock patients if adequate fluid resuscitation and vasopressor therapy are able to restore hemodynamic stability (see goals for Initial Resuscitation). In case this is not achievable, we suggest intravenous hydrocortisone alone at a dose of 200 mg per day (grade 2C).
2. Not using the ACTH stimulation test to identify adults with septic shock who should receive hydrocortisone (grade 2B).
3. In treated patients hydrocortisone tapered when vasopressors are no longer required (grade 2D).
4. Corticosteroids not be administered for the treatment of sepsis in the absence of shock (grade 1D).
5. When hydrocortisone is given, use continuous flow (grade 2D).

with those receiving crystalloids (seven trials,  $n = 1441$ ), the OR of dying was significantly reduced for albumin-treated patients (OR, 0.78; 95% CI, 0.62–0.99;  $I^2 = 0\%$ ). A multicenter randomized trial ( $n = 794$ ) in patients with septic shock compared intravenous albumin (20 g, 20%) every 8 hrs for 3 days to intravenous saline solution (130); albumin therapy was associated with 2.2% absolute

reduction in 28-day mortality (from 26.3% to 24.1%), but did not achieve statistical significance. These data support a low-level recommendation regarding the use of albumin in patients with sepsis and septic shock (personal communication from J.P. Mira and as presented at the 32nd International ISICEM Congress 2012, Brussels and the 25th ESICM Annual Congress 2012, Lisbon).

4. We recommend an initial fluid challenge in patients with sepsis-induced tissue hypoperfusion with suspicion of hypovolemia to achieve a minimum of 30 mL/kg of crystalloids (a portion of this may be albumin equivalent). More rapid administration and greater amounts of fluid may be needed in some patients (see Initial Resuscitation recommendations) (grade 1C).
5. We recommend that a fluid challenge technique be applied wherein fluid administration is continued as long as there is hemodynamic improvement either based on dynamic (eg, change in pulse pressure, stroke volume variation) or static (eg, arterial pressure, heart rate) variables (UG).

**Rationale.** Dynamic tests to assess patients' responsiveness to fluid replacement have become very popular in recent years in the ICU (131). These tests are based on monitoring changes in stroke volume during mechanical ventilation or after passive leg raising in spontaneously breathing patients. A systematic review (29 trials,  $n = 685$  critically ill patients) looked at the association between stroke volume variation, pulse pressure variation, and/or stroke volume variation and the change in stroke volume/cardiac index after a fluid or positive end-expiratory pressure challenge (132). The diagnostic OR of fluid responsiveness was 59.86 (14 trials, 95% CI, 23.88–150.05) and 27.34 (five trials, 95% CI, 3.46–55.53) for the pulse pressure variation and the stroke volume variation, respectively. Utility of pulse pressure variation and stroke volume variation is limited in the presence of atrial fibrillation, spontaneous breathing, and low pressure support breathing. These techniques generally require sedation.

## H. Vasopressors

1. We recommend that vasopressor therapy initially target a MAP of 65 mm Hg (grade 1C).

**Rationale.** Vasopressor therapy is required to sustain life and maintain perfusion in the face of life-threatening hypotension, even when hypovolemia has not yet been resolved. Below a threshold MAP, autoregulation in critical vascular beds can be lost, and perfusion can become linearly dependent on pressure. Thus, some patients may require vasopressor therapy to achieve a minimal perfusion pressure and maintain adequate flow (133, 134). The titration of norepinephrine to a MAP as low as 65 mm Hg has been shown to preserve tissue perfusion (134). Note that the consensus definition of sepsis-induced hypotension for use of MAP in the diagnosis of severe sepsis is different (MAP < 70 mm Hg) from the evidence-based target of 65 mm Hg used in this recommendation. In any case, the optimal MAP should be individualized as it may be higher in patients with atherosclerosis and/or previous hypertension than in young patients without cardiovascular comorbidity. For example, a MAP of 65 mm Hg might be too low in a patient with severe uncontrolled hypertension; in a young, previously normotensive patient, a lower MAP might be adequate. Supplementing endpoints, such as blood pressure, with assessment of regional and global perfusion, such as blood lactate concentrations, skin perfusion, mental status, and urine output, is important. Adequate fluid resuscitation

is a fundamental aspect of the hemodynamic management of patients with septic shock and should ideally be achieved before vasopressors and inotropes are used; however, using vasopressors early as an emergency measure in patients with severe shock is frequently necessary, as when diastolic blood pressure is too low. When that occurs, great effort should be directed to weaning vasopressors with continuing fluid resuscitation.

2. We recommend norepinephrine as the first-choice vasopressor (grade 1B).
3. We suggest epinephrine (added to and potentially substituted for norepinephrine) when an additional agent is needed to maintain adequate blood pressure (grade 2B).
4. Vasopressin (up to 0.03 U/min) can be added to norepinephrine with the intent of raising MAP to target or decreasing norepinephrine dosage (UG).
5. Low-dose vasopressin is not recommended as the single initial vasopressor for treatment of sepsis-induced hypotension, and vasopressin doses higher than 0.03–0.04 U/min should be reserved for salvage therapy (failure to achieve an adequate MAP with other vasopressor agents) (UG).
6. We suggest dopamine as an alternative vasopressor agent to norepinephrine only in highly selected patients (eg, patients with low risk of tachyarrhythmias and absolute or relative bradycardia) (grade 2C).
7. Phenylephrine is not recommended in the treatment of septic shock except in the following circumstances: (a) norepinephrine is associated with serious arrhythmias, (b) cardiac output is known to be high and blood pressure persistently low, or (c) as salvage therapy when combined inotrope/vasopressor drugs and low-dose vasopressin have failed to achieve the MAP target (grade 1C).

**Rationale.** The physiologic effects of vasopressor and combined inotrope/vasopressors selection in septic shock are set out in an extensive number of literature entries (135–147). **Table 7** depicts a GRADEpro Summary of Evidence Table comparing dopamine and norepinephrine in the treatment of septic shock. Dopamine increases MAP and cardiac output, primarily due to an increase in stroke volume and heart rate. Norepinephrine increases MAP due to its vasoconstrictive effects, with little change in heart rate and less increase in stroke volume compared with dopamine. Norepinephrine is more potent than dopamine and may be more effective at reversing hypotension in patients with septic shock. Dopamine may be particularly useful in patients with compromised systolic function but causes more tachycardia and may be more arrhythmogenic than norepinephrine (148). It may also influence the endocrine response via the hypothalamic pituitary axis and have immunosuppressive effects. However, information from five randomized trials ( $n = 1993$  patients with septic shock) comparing norepinephrine to dopamine does not support the routine use of dopamine in the management of septic shock (136, 149–152). Indeed, the relative risk of short-term mortality was 0.91 (95% CI, 0.84–1.00; fixed effect;  $I^2 = 0\%$ ) in favor of norepinephrine. A recent meta-analysis showed dopamine was associated with an increased risk (RR, 1.10 [1.01–1.20];  $p = 0.035$ ); in the two trials that reported

**TABLE 7. Norepinephrine Compared With Dopamine in Severe Sepsis Summary of Evidence**

<b>Norepinephrine compared with dopamine in severe sepsis</b>						
Outcomes	Illustrative Comparative Risks <sup>a</sup> (95% CI)		Relative Effect (95% CI)	No. of Participants (Studies)	Quality of the Evidence (GRADE)	Comments
	Assumed Risk	Corresponding Risk				
	Dopamine	Norepinephrine				
Short-term mortality	530 per 1000	Study population 482 per 1000 (440 to 524)	RR 0.91 (0.83 to 0.99)	2043 (6 studies)	⊕⊕⊕⊖ moderate <sup>b,c</sup>	
Serious adverse events —Supraventricular arrhythmias	229 per 1000	Study population 82 per 1000 (34 to 195)	RR 0.47 (0.38 to 0.58)	1931 (2 studies)	⊕⊕⊕⊖ moderate <sup>b,c</sup>	
Serious adverse events—Ventricular arrhythmias	39 per 1000	Study population 15 per 1000 (8 to 27)	RR 0.35 (0.19 to 0.66)	1931 (2 studies)	⊕⊕⊕⊖ moderate <sup>b,c</sup>	

<sup>a</sup>The assumed risk is the control group risk across studies. The corresponding risk (and its 95% CI) is based on the assumed risk in the comparison group and the relative effect of the intervention (and its 95% CI). CI = confidence interval, RR = risk ratio.

<sup>b</sup>Strong heterogeneity in the results ( $I^2 = 85\%$ ), however this reflects degree of effect, not direction of effect. We have decided not to lower the evidence quality.

<sup>c</sup>Effect results in part from hypovolemic and cardiogenic shock patients in De Backer, *N Engl J Med* 2010. We have lowered the quality of evidence one level for indirectness.

arrhythmias, these were more frequent with dopamine than with norepinephrine (RR, 2.34 [1.46–3.77];  $p = 0.001$ ) (153).

Although some human and animal studies suggest epinephrine has deleterious effects on splanchnic circulation and produces hyperlactatemia, no clinical evidence shows that epinephrine results in worse outcomes, and it should be the first alternative to norepinephrine. Indeed, information from 4 randomized trials ( $n = 540$ ) comparing norepinephrine to epinephrine found no evidence for differences in the risk of dying (RR, 0.96; CI, 0.77–1.21; fixed effect;  $I^2 = 0\%$ ) (142, 147, 154, 155). Epinephrine may increase aerobic lactate production via stimulation of skeletal muscles'  $\beta_2$ -adrenergic receptors and thus may prevent the use of lactate clearance to guide resuscitation. With its almost pure  $\alpha$ -adrenergic effects, phenylephrine is the adrenergic agent least likely to produce tachycardia, but it may decrease stroke volume and is therefore not recommended for use in the treatment of septic shock except in circumstances where norepinephrine is: a) associated with serious arrhythmias, or b) cardiac output is known to be high, or c) as salvage therapy when other vasopressor agents have failed to achieve target MAP (156). Vasopressin levels in septic shock have been reported to be lower than anticipated for a shock state (157). Low doses of vasopressin may be effective in raising blood pressure in patients, refractory to other vasopressors and may have other potential physiologic benefits (158–163). Terlipressin

has similar effects but is long acting (164). Studies show that vasopressin concentrations are elevated in early septic shock, but decrease to normal range in the majority of patients between 24 and 48 hrs as shock continues (165). This has been called *relative vasopressin deficiency* because in the presence of hypotension, vasopressin would be expected to be elevated. The significance of this finding is unknown. The VASST trial, an RCT comparing norepinephrine alone to norepinephrine plus vasopressin at 0.03 U/min, showed no difference in outcome in the intent-to-treat population (166). An a priori defined subgroup analysis demonstrated that survival among patients receiving  $< 15 \mu\text{g}/\text{min}$  norepinephrine at the time of randomization was better with the addition of vasopressin; however, the pretrial rationale for this stratification was based on exploring potential benefit in the population requiring  $\geq 15 \mu\text{g}/\text{min}$  norepinephrine. Higher doses of vasopressin have been associated with cardiac, digital, and splanchnic ischemia and should be reserved for situations where alternative vasopressors have failed (167). Information from seven trials ( $n = 963$  patients with septic shock) comparing norepinephrine with vasopressin (or terlipressin) does not support the routine use of vasopressin or its analog terlipressin (93, 95, 97, 99, 159, 161, 164, 166, 168–170). Indeed, the relative risk of dying was 1.12 (95% CI, 0.96–1.30; fixed effects;  $I^2 = 0\%$ ). However, the risk of supraventricular arrhythmias was increased with norepinephrine (RR, 7.25; 95% CI, 2.30–22.90; fixed effect;

$P^2 = 0\%$ ). Cardiac output measurement targeting maintenance of a normal or elevated flow is desirable when these pure vasopressors are instituted.

8. We recommend that low-dose dopamine not be used for renal protection (grade 1A).

**Rationale.** A large randomized trial and meta-analysis comparing low-dose dopamine to placebo found no difference in either primary outcomes (peak serum creatinine, need for renal replacement, urine output, time to recovery of normal renal function) or secondary outcomes (survival to either ICU or hospital discharge, ICU stay, hospital stay, arrhythmias) (171, 172). Thus, the available data do not support administration of low doses of dopamine solely to maintain renal function.

9. We recommend that all patients requiring vasopressors have an arterial catheter placed as soon as practical if resources are available (UG).

**Rationale.** In shock states, estimation of blood pressure using a cuff is commonly inaccurate; use of an arterial cannula provides a more appropriate and reproducible measurement of arterial pressure. These catheters also allow continuous analysis so that decisions regarding therapy can be based on immediate and reproducible blood pressure information.

## I. Inotropic Therapy

1. We recommend that a trial of dobutamine infusion up to 20  $\mu\text{g}/\text{kg}/\text{min}$  be administered or added to vasopressor (if in use) in the presence of: a) myocardial dysfunction, as suggested by elevated cardiac filling pressures and low cardiac output, or b) ongoing signs of hypoperfusion, despite achieving adequate intravascular volume and adequate MAP (grade 1C).
2. We recommend against the use of a strategy to increase cardiac index to predetermined supranormal levels (grade 1B).

**Rationale.** Dobutamine is the first choice inotrope for patients with measured or suspected low cardiac output in the presence of adequate left ventricular filling pressure (or clinical assessment of adequate fluid resuscitation) and adequate MAP. Septic patients who remain hypotensive after fluid resuscitation may have low, normal, or increased cardiac outputs. Therefore, treatment with a combined inotrope/vasopressor, such as norepinephrine or epinephrine, is recommended if cardiac output is not measured. When the capability exists for monitoring cardiac output in addition to blood pressure, a vasopressor, such as norepinephrine, may be used separately to target specific levels of MAP and cardiac output. Large prospective clinical trials, which included critically ill ICU patients who had severe sepsis, failed to demonstrate benefit from increasing oxygen delivery to supranormal targets by use of dobutamine (173, 174). These studies did not specifically target patients with severe sepsis and did not target the first 6 hrs of resuscitation. If evidence of tissue hypoperfusion persists despite adequate intravascular volume and adequate MAP, a viable alternative (other than reversing underlying insult) is to add inotropic therapy.

## J. Corticosteroids

1. We suggest not using intravenous hydrocortisone as a treatment of adult septic shock patients if adequate fluid resuscitation and vasopressor therapy are able to restore hemodynamic stability (see goals for Initial Resuscitation). If this is not achievable, we suggest intravenous hydrocortisone alone at a dose of 200 mg per day (grade 2C).

**Rationale.** The response of septic shock patients to fluid and vasopressor therapy seems to be an important factor in selection of patients for optional hydrocortisone therapy. One French multicenter RCT of patients in vasopressor-unresponsive septic shock (hypotension despite fluid resuscitation and vasopressors for more than 60 mins) showed significant shock reversal and reduction of mortality rate in patients with relative adrenal insufficiency (defined as postadrenocorticotrophic hormone [ACTH] cortisol increase  $\leq 9 \mu\text{g}/\text{dL}$ ) (175). Two smaller RCTs also showed significant effects on shock reversal with steroid therapy (176, 177). In contrast, a large, European multicenter trial (CORTICUS) that enrolled patients without sustained shock and had a lower risk of death than the French trial failed to show a mortality benefit with steroid therapy (178). Unlike the French trial that only enrolled shock patients with blood pressure unresponsive to vasopressor therapy, the CORTICUS study included patients with septic shock regardless of how the blood pressure responded to vasopressors; the study baseline (placebo) 28-day mortality rate was 61% and 31%, respectively. The use of the ACTH test (responders and nonresponders) did not predict the faster resolution of shock. In recent years, several systematic reviews have examined the use of low-dose hydrocortisone in septic shock with contradictory results: Annane et al (179) analyzed the results of 12 studies and calculated a significant reduction in 28-day mortality with prolonged low-dose steroid treatment in adult septic shock patients (RR, 0.84; 95% CI, 0.72–0.97;  $p = 0.02$ ) (180). In parallel, Sligl and colleagues (180) used a similar technique, but only identified eight studies for their meta-analysis, six of which had a high-level RCT design with low risk of bias (181). In contrast to the aforementioned review, this analysis revealed no statistically significant difference in mortality (RR, 1.00; 95% CI, 0.84–1.18). Both reviews, however, confirmed the improved shock reversal by using low-dose hydrocortisone (180, 181). A recent review on the use of steroids in adult septic shock underlined the importance of selection of studies for systematic analysis (181) and identified only 6 high-level RCTs as adequate for systematic review (175–178, 182, 183). When only these six studies are analyzed, we found that in “low risk” patients from three studies (ie, those with a placebo mortality rate of less than 50%, which represents the majority of all patients), hydrocortisone failed to show any benefit on outcome (RR, 1.06). The minority of patients from the remaining three studies, who had a placebo mortality of greater than 60%, showed a nonsignificant trend to lower mortality by using hydrocortisone (see **Supplemental Digital Content 4**, <http://links.lww.com/CCM/A615>, Summary of Evidence Table).



- We suggest not using the ACTH stimulation test to identify the subset of adults with septic shock who should receive hydrocortisone (grade 2B).

**Rationale.** In one study, the observation of a potential interaction between steroid use and ACTH test was not statistically significant (175). Furthermore, no evidence of this distinction was observed between responders and nonresponders in a recent multicenter trial (178). Random cortisol levels may still be useful for absolute adrenal insufficiency; however, for septic shock patients who suffer from relative adrenal insufficiency (no adequate stress response), random cortisol levels have not been demonstrated to be useful. Cortisol immunoassays may over- or underestimate the actual cortisol level, affecting the assignment of patients to responders or nonresponders (184). Although the clinical significance is not clear, it is now recognized that etomidate, when used for induction for intubation, will suppress the hypothalamic-pituitary-adrenal axis (185, 186). Moreover, a subanalysis of the CORTICUS trial (178) revealed that the use of etomidate before application of low-dose steroids was associated with an increased 28-day mortality rate (187). An inappropriately low random cortisol level ( $< 18 \mu\text{g/dL}$ ) in a patient with shock would be considered an indication for steroid therapy along traditional adrenal insufficiency guidelines.

- We suggest that clinicians taper the treated patient from steroid therapy when vasopressors are no longer required (grade 2D).

**Rationale.** There has been no comparative study between a fixed-duration and clinically guided regimen or between tapering and abrupt cessation of steroids. Three RCTs used a fixed-duration protocol for treatment (175, 177, 178), and therapy was decreased after shock resolution in two RCTs (176, 182). In four studies, steroids were tapered over several days (176–178, 182), and steroids were withdrawn abruptly in two RCTs (175, 183). One crossover study showed hemodynamic and immunologic rebound effects after abrupt cessation of corticosteroids (188). Furthermore, a study revealed that there is no difference in outcome of septic shock patients if low-dose hydrocortisone is used for 3 or 7 days; hence, no recommendation can be given with regard to the optimal duration of hydrocortisone therapy (189).

- We recommend that corticosteroids not be administered for the treatment of sepsis in the absence of shock (grade 1D).

**Rationale.** Steroids may be indicated in the presence of a history of steroid therapy or adrenal dysfunction, but whether low-dose steroids have a preventive potency in reducing the incidence of severe sepsis and septic shock in critically ill patients cannot be answered. A preliminary study of stress-dose level steroids in community-acquired pneumonia showed improved outcome measures in a small population (190), and a recent confirmatory RCT revealed reduced hospital length of stay without affecting mortality (191).

- When low-dose hydrocortisone is given, we suggest using continuous infusion rather than repetitive bolus injections (grade 2D).

**Rationale.** Several randomized trials on the use of low-dose hydrocortisone in septic shock patients revealed a significant increase of hyperglycemia and hypernatremia (175) as side effects. A small prospective study demonstrated that repetitive bolus application of hydrocortisone leads to a significant increase in blood glucose; this peak effect was not detectable during continuous infusion. Furthermore, considerable inter-individual variability was seen in this blood glucose peak after the hydrocortisone bolus (192). Although an association of hyperglycemia and hypernatremia with patient outcome measures could not be shown, good practice includes strategies for avoidance and/or detection of these side effects.

## SUPPORTIVE THERAPY OF SEVERE SEPSIS (TABLE 8)

### K. Blood Product Administration

- Once tissue hypoperfusion has resolved and in the absence of extenuating circumstances, such as myocardial ischemia, severe hypoxemia, acute hemorrhage, or ischemic coronary artery disease, we recommend that red blood cell transfusion occur when the hemoglobin concentration decreases to  $< 7.0 \text{ g/dL}$  to target a hemoglobin concentration of 7.0 to 9.0 g/dL in adults (grade 1B).

**Rationale.** Although the optimum hemoglobin concentration for patients with severe sepsis has not been specifically investigated, the Transfusion Requirements in Critical Care trial suggested that a hemoglobin level of 7 to 9 g/dL, compared with 10 to 12 g/dL, was not associated with increased mortality in critically ill adults (193). No significant differences in 30-day mortality rates were observed between treatment groups in the subgroup of patients with severe infections and septic shock (22.8% and 29.7%, respectively;  $p = 0.36$ ).

Although less applicable to septic patients, results of a randomized trial in patients undergoing cardiac surgery with cardiopulmonary bypass support a restrictive transfusion strategy using a threshold hematocrit of  $< 24\%$  (hemoglobin  $\approx 8 \text{ g/dL}$ ) as equivalent to a transfusion threshold of hematocrit of  $< 30\%$  (hemoglobin  $\approx 10 \text{ g/dL}$ ) (194). Red blood cell transfusion in septic patients increases oxygen delivery but does not usually increase oxygen consumption (195–197). The transfusion threshold of 7 g/dL contrasts with early goal-directed resuscitation protocols that use a target hematocrit of 30% in patients with low  $\text{ScvO}_2$  during the first 6 hrs of resuscitation of septic shock (13).

- We recommend not using erythropoietin as a specific treatment of anemia associated with severe sepsis (grade 1B).

**Rationale.** No specific information regarding erythropoietin use in septic patients is available, but clinical trials of erythropoietin administration in critically ill patients show some decrease in red cell transfusion requirement with no effect on clinical outcome (198, 199). The effect of erythropoietin in severe sepsis and septic shock would not be expected to be more beneficial than in other critical

conditions. Patients with severe sepsis and septic shock may have coexisting conditions that meet indications for the use of erythropoietin.

3. We suggest that fresh frozen plasma not be used to correct laboratory clotting abnormalities in the absence of bleeding or planned invasive procedures (grade 2D).

**Rationale.** Although clinical studies have not assessed the impact of transfusion of fresh frozen plasma on outcomes in critically ill patients, professional organizations have recommended it for coagulopathy when there is a documented deficiency of coagulation factors (increased prothrombin time, international normalized ratio, or partial thromboplastin time) and the presence of active bleeding or before surgical or invasive procedures (200–203). In addition, transfusion of fresh frozen plasma usually fails to correct the prothrombin time in non-bleeding patients with mild abnormalities (204, 205). No studies suggest that correction of more severe coagulation abnormalities benefits patients who are not bleeding.

4. We recommend against antithrombin administration for the treatment of severe sepsis and septic shock (grade 1B).

**Rationale.** A phase III clinical trial of high-dose antithrombin did not demonstrate any beneficial effect on 28-day all-cause mortality in adults with severe sepsis and septic shock. High-dose antithrombin was associated with an increased risk of bleeding when administered with heparin (206). Although a post hoc subgroup analysis of patients with severe sepsis and high risk of death showed better survival in patients receiving antithrombin, this agent cannot be recommended until further clinical trials are performed (207).

5. In patients with severe sepsis, we suggest that platelets be administered prophylactically when counts are  $\leq 10,000/\text{mm}^3$  ( $10 \times 10^9/\text{L}$ ) in the absence of apparent bleeding, as well when counts are  $\leq 20,000/\text{mm}^3$  ( $20 \times 10^9/\text{L}$ ) if the patient has a significant risk of bleeding. Higher platelet counts ( $\geq 50,000/\text{mm}^3$  [ $50 \times 10^9/\text{L}$ ]) are advised for active bleeding, surgery, or invasive procedures (grade 2D).

**Rationale.** Guidelines for transfusion of platelets are derived from consensus opinion and experience in patients with chemotherapy-induced thrombocytopenia. Patients with severe sepsis are likely to have some limitation of platelet production similar to that in chemotherapy-treated patients, but they also are likely to have increased platelet consumption. Recommendations take into account the etiology of thrombocytopenia, platelet dysfunction, risk of bleeding, and presence of concomitant disorders (200, 202, 203, 208, 209). Factors that may increase the bleeding risk and indicate the need for a higher platelet count are frequently present in patients with severe sepsis. Sepsis itself is considered to be a risk factor for bleeding in patients with chemotherapy-induced thrombocytopenia. Other factors considered to increase the risk of bleeding in patients with severe sepsis include temperature higher than  $38^\circ\text{C}$ , recent minor hemorrhage, rapid decrease in platelet count, and other coagulation abnormalities (203, 208, 209).

## L. Immunoglobulins

1. We suggest not using intravenous immunoglobulins in adult patients with severe sepsis or septic shock (grade 2B).

**Rationale.** One larger multicenter RCT ( $n = 624$ ) (210) in adult patients and one large multinational RCT in infants with neonatal sepsis ( $n = 3493$ ) (211) found no benefit for intravenous immunoglobulin (IVIG). (For more on this trial, see the section, Pediatric Considerations.) A meta-analysis by the Cochrane collaboration, which did not include this most recent RCT, identified 10 polyclonal IVIG trials ( $n = 1430$ ) and seven trials on immunoglobulin (Ig) M-enriched polyclonal IVIG ( $n = 528$ ) (212). Compared with placebo, IVIG resulted in a significant reduction in mortality (RR, 0.81 and 95% CI, 0.70–0.93; and RR, 0.66 and 95% CI, 0.51–0.85, respectively). Also the subgroup of IgM-enriched IVIGs ( $n = 7$  trials) showed a significant reduction in mortality rates compared with placebo (RR, 0.66; 95% CI, 0.51–0.85). Trials with low risk of bias showed no reduction in mortality with polyclonal IVIG (RR, 0.97; 95% CI, 0.81–1.15; five trials,  $n = 945$ ). Three of these trials (210, 213, 214) used standard polyclonal IVIG and two IgM-enriched IVIG (215, 216).

These findings are in accordance with those of two older meta-analyses (217, 218) from other Cochrane authors. One systematic review (217) included a total of 21 trials and showed a relative risk of death of 0.77 with immunoglobulin treatment (95% CI, 0.68–0.88); however, the results of only high-quality trials (total of 763 patients) showed a relative risk of 1.02 (95% CI, 0.84–1.24). Similarly, Laupland et al (218) found a significant reduction in mortality with the use of IVIG treatment (OR, 0.66; 95% CI, 0.53–0.83;  $p < 0.005$ ). When only high-quality studies were pooled, the OR for mortality was 0.96 (95% CI, 0.71–1.3;  $p = 0.78$ ). Two meta-analyses, which used less strict criteria to identify sources of bias or did not state their criteria for the assessment of study quality, found significant improvement in patient mortality with IVIG treatment (219, 220). In contrast to the most recent Cochrane review, Kreymann et al (219) classified five studies that investigated IgM-enriched preparation as high-quality studies, combining studies in adults and neonates, and found an OR for mortality of 0.5 (95% CI, 0.34–0.73).

Most IVIG studies are small, some have methodological flaws; the only large study ( $n = 624$ ) showed no effect (210). Subgroup effects between IgM-enriched and nonenriched formulations reveal substantial heterogeneity. In addition, indirectness and publication bias were considered in grading this recommendation. The low-quality evidence led to the grading as a weak recommendation. The statistical information that comes from the high-quality trials does not support a beneficial effect of polyclonal IVIG. We encourage conducting large multicenter studies to further evaluate the effectiveness of other polyclonal immunoglobulin preparations given intravenously in patients with severe sepsis.

## M. Selenium

1. We suggest not using intravenous selenium to treat severe sepsis (grade 2C).

**TABLE 8. Recommendations: Other Supportive Therapy of Severe Sepsis****K. Blood Product Administration**

1. Once tissue hypoperfusion has resolved and in the absence of extenuating circumstances, such as myocardial ischemia, severe hypoxemia, acute hemorrhage, or ischemic heart disease, we recommend that red blood cell transfusion occur only when hemoglobin concentration decreases to  $<7.0$  g/dL to target a hemoglobin concentration of 7.0–9.0 g/dL in adults (grade 1B).
2. Not using erythropoietin as a specific treatment of anemia associated with severe sepsis (grade 1B).
3. Fresh frozen plasma not be used to correct laboratory clotting abnormalities in the absence of bleeding or planned invasive procedures (grade 2D).
4. Not using antithrombin for the treatment of severe sepsis and septic shock (grade 1B).
5. In patients with severe sepsis, administer platelets prophylactically when counts are  $<10,000/\text{mm}^3$  ( $10 \times 10^9/\text{L}$ ) in the absence of apparent bleeding. We suggest prophylactic platelet transfusion when counts are  $<20,000/\text{mm}^3$  ( $20 \times 10^9/\text{L}$ ) if the patient has a significant risk of bleeding. Higher platelet counts ( $\geq 50,000/\text{mm}^3$  [ $50 \times 10^9/\text{L}$ ]) are advised for active bleeding, surgery, or invasive procedures (grade 2D).

**L. Immunoglobulins**

1. Not using intravenous immunoglobulins in adult patients with severe sepsis or septic shock (grade 2B).

**M. Selenium**

1. Not using intravenous selenium for the treatment of severe sepsis (grade 2C).

**N. History of Recommendations Regarding Use of Recombinant Activated Protein C (rhAPC)**

A history of the evolution of SSC recommendations as to rhAPC (no longer available) is provided.

**O. Mechanical Ventilation of Sepsis-Induced Acute Respiratory Distress Syndrome (ARDS)**

1. Target a tidal volume of 6 mL/kg predicted body weight in patients with sepsis-induced ARDS (grade 1A vs. 12 mL/kg).
2. Plateau pressures be measured in patients with ARDS and initial upper limit goal for plateau pressures in a passively inflated lung be  $\leq 30$  cm H<sub>2</sub>O (grade 1B).
3. Positive end-expiratory pressure (PEEP) be applied to avoid alveolar collapse at end expiration (atelectotrauma) (grade 1B).
4. Strategies based on higher rather than lower levels of PEEP be used for patients with sepsis-induced moderate or severe ARDS (grade 2C).
5. Recruitment maneuvers be used in sepsis patients with severe refractory hypoxemia (grade 2C).
6. Prone positioning be used in sepsis-induced ARDS patients with a  $\text{PaO}_2/\text{FiO}_2$  ratio  $\leq 100$  mm Hg in facilities that have experience with such practices (grade 2B).
7. That mechanically ventilated sepsis patients be maintained with the head of the bed elevated to 30–45 degrees to limit aspiration risk and to prevent the development of ventilator-associated pneumonia (grade 1B).
8. That noninvasive mask ventilation (NIV) be used in that minority of sepsis-induced ARDS patients in whom the benefits of NIV have been carefully considered and are thought to outweigh the risks (grade 2B).
9. That a weaning protocol be in place and that mechanically ventilated patients with severe sepsis undergo spontaneous breathing trials regularly to evaluate the ability to discontinue mechanical ventilation when they satisfy the following criteria: a) arousable; b) hemodynamically stable (without vasopressor agents); c) no new potentially serious conditions; d) low ventilatory and end-expiratory pressure requirements; and e) low  $\text{FiO}_2$  requirements which can be met safely delivered with a face mask or nasal cannula. If the spontaneous breathing trial is successful, consideration should be given for extubation (grade 1A).
10. Against the routine use of the pulmonary artery catheter for patients with sepsis-induced ARDS (grade 1A).
11. A conservative rather than liberal fluid strategy for patients with established sepsis-induced ARDS who do not have evidence of tissue hypoperfusion (grade 1C).
12. In the absence of specific indications such as bronchospasm, not using beta 2-agonists for treatment of sepsis-induced ARDS (grade 1B).

**P. Sedation, Analgesia, and Neuromuscular Blockade in Sepsis**

1. Continuous or intermittent sedation be minimized in mechanically ventilated sepsis patients, targeting specific titration endpoints (grade 1B).
2. Neuromuscular blocking agents (NMBAs) be avoided if possible in the septic patient *without ARDS* due to the risk of prolonged neuromuscular blockade following discontinuation. If NMBAs must be maintained, either intermittent bolus as required or continuous infusion with train-of-four monitoring of the depth of blockade should be used (grade 1C).

(Continued)

**TABLE 8. (Continued) Recommendations: Other Supportive Therapy of Severe Sepsis**

3. A short course of NMBA of not greater than 48 hours for patients *with* early sepsis-induced ARDS and a  $P_{aO_2}/F_{iO_2}$  < 150 mm Hg (grade 2C).

**Q. Glucose Control**

1. A protocolized approach to blood glucose management in ICU patients with severe sepsis commencing insulin dosing when 2 consecutive blood glucose levels are >180 mg/dL. This protocolized approach should target an upper blood glucose  $\leq$ 180 mg/dL rather than an upper target blood glucose  $\leq$  110 mg/dL (grade 1A).
2. Blood glucose values be monitored every 1–2 hrs until glucose values and insulin infusion rates are stable and then every 4 hrs thereafter (grade 1C).
3. Glucose levels obtained with point-of-care testing of capillary blood be interpreted with caution, as such measurements may not accurately estimate arterial blood or plasma glucose values (UG).

**R. Renal Replacement Therapy**

1. Continuous renal replacement therapies and intermittent hemodialysis are equivalent in patients with severe sepsis and acute renal failure (grade 2B).
2. Use continuous therapies to facilitate management of fluid balance in hemodynamically unstable septic patients (grade 2D).

**S. Bicarbonate Therapy**

1. Not using sodium bicarbonate therapy for the purpose of improving hemodynamics or reducing vasopressor requirements in patients with hypoperfusion-induced lactic acidemia with pH  $\geq$ 7.15 (grade 2B).

**T. Deep Vein Thrombosis Prophylaxis**

1. Patients with severe sepsis receive daily pharmacoprophylaxis against venous thromboembolism (VTE) (grade 1B). This should be accomplished with daily subcutaneous low-molecular weight heparin (LMWH) (grade 1B versus twice daily UFH, grade 2C versus three times daily UFH). If creatinine clearance is <30 mL/min, use dalteparin (grade 1A) or another form of LMWH that has a low degree of renal metabolism (grade 2C) or UFH (grade 1A).
2. Patients with severe sepsis be treated with a combination of pharmacologic therapy and intermittent pneumatic compression devices whenever possible (grade 2C).
3. Septic patients who have a contraindication for heparin use (eg, thrombocytopenia, severe coagulopathy, active bleeding, recent intracerebral hemorrhage) not receive pharmacoprophylaxis (grade 1B), but receive mechanical prophylactic treatment, such as graduated compression stockings or intermittent compression devices (grade 2C), unless contraindicated. When the risk decreases start pharmacoprophylaxis (grade 2C).

**U. Stress Ulcer Prophylaxis**

1. Stress ulcer prophylaxis using H<sub>2</sub> blocker or proton pump inhibitor be given to patients with severe sepsis/septic shock who have bleeding risk factors (grade 1B).
2. When stress ulcer prophylaxis is used, proton pump inhibitors rather than H<sub>2</sub>RA (grade 2D)
3. Patients without risk factors do not receive prophylaxis (grade 2B).

**V. Nutrition**

1. Administer oral or enteral (if necessary) feedings, as tolerated, rather than either complete fasting or provision of only intravenous glucose within the first 48 hours after a diagnosis of severe sepsis/septic shock (grade 2C).
2. Avoid mandatory full caloric feeding in the first week but rather suggest low dose feeding (eg, up to 500 calories per day), advancing only as tolerated (grade 2B).
3. Use intravenous glucose and enteral nutrition rather than total parenteral nutrition (TPN) alone or parenteral nutrition in conjunction with enteral feeding in the first 7 days after a diagnosis of severe sepsis/septic shock (grade 2B).
4. Use nutrition with no specific immunomodulating supplementation rather than nutrition providing specific immunomodulating supplementation in patients with severe sepsis (grade 2C).

**W. Setting Goals of Care**

1. Discuss goals of care and prognosis with patients and families (grade 1B).
2. Incorporate goals of care into treatment and end-of-life care planning, utilizing palliative care principles where appropriate (grade 1B).
3. Address goals of care as early as feasible, but no later than within 72 hours of ICU admission (grade 2C).



**Rationale.** Selenium was administered in the hope that it could correct the known reduction of selenium concentration in sepsis patients and provide a pharmacologic effect through an antioxidant defense. Although some RCTs are available, the evidence on the use of intravenous selenium is still very weak. Only one large clinical trial has examined the effect on mortality rates, and no significant impact was reported on the intent-to-treat population with severe systemic inflammatory response syndrome, sepsis, or septic shock (OR, 0.66; 95% CI, 0.39–1.10;  $p = 0.109$ ) (221). Overall, there was a trend toward a concentration-dependent reduction in mortality; no differences in secondary outcomes or adverse events were detected. Finally, no comment on standardization of sepsis management was included in this study, which recruited 249 patients over a period of 6 years (1999–2004) (221).

A French RCT in a small population revealed no effect on primary (shock reversal) or secondary (days on mechanical ventilation, ICU mortality) endpoints (222). Another small RCT revealed less early VAP in the selenium group ( $p = 0.04$ ), but no difference in late VAP or secondary outcomes such as ICU or hospital mortality (223). This is in accordance with two RCTs that resulted in reduced number of infectious episodes (224) or increase in glutathione peroxidase concentrations (225); neither study, however, showed a beneficial effect on secondary outcome measures (renal replacement, ICU mortality) (224, 225).

A more recent large RCT tried to determine if the addition of relatively low doses of supplemental selenium (glutamine was also tested in a two-factorial design) to parenteral nutrition in critically ill patients reduces infections and improves outcome (226). Selenium supplementation did not significantly affect the development of a new infection (OR, 0.81; 95% CI, 0.57–1.15), and the 6-month mortality rate was not unaffected (OR, 0.89; 95% CI, 0.62–1.29). In addition, length of stay, days of antibiotic use, and modified Sequential Organ Failure Assessment score were not significantly affected by selenium (227).

In addition to the lack of evidence, the questions of optimal dosing and application mode remain unanswered. Reported high-dose regimens have involved a loading dose followed by an infusion, while animal trials suggest that bolus dosing could be more effective (227); this, however, has not been tested in humans. These unsolved problems require additional trials, and we encourage conducting large multicenter studies to further evaluate the effectiveness of intravenous selenium in patients with severe sepsis. This recommendation does not exclude the use of low-dose selenium as part of the standard minerals and oligo-elements used during total parenteral nutrition.

## N. History of Recommendations Regarding Use of Recombinant Activated Protein C

Recombinant human activated protein C (rhAPC) was approved for use in adult patients in a number of countries in 2001 following the PROWESS (Recombinant Human Activated Protein C Worldwide Evaluation in Severe Sepsis) trial, which enrolled 1,690 severe sepsis patients and showed a significant reduction in mortality (24.7%) with rhAPC compared with placebo (30.8%,  $p = 0.005$ ) (228). The 2004 SSC

guidelines recommended use of rhAPC in line with the product labeling instructions required by the U.S. and European regulatory authorities with a grade B quality of evidence (7, 8).

By the time of publication of the 2008 SSC guidelines, additional studies of rhAPC in severe sepsis (as required by regulatory agencies) had shown it ineffective in less severely ill patients with severe sepsis as well as in children (229, 230). The 2008 SSC recommendations reflected these findings, and the strength of the rhAPC recommendation was downgraded to a suggestion for use in adult patients with a clinical assessment of high risk of death, most of whom will have Acute Physiology and Chronic Health Evaluation (APACHE) II scores  $\geq 25$  or multiple organ failure (grade 2C; quality of evidence was also downgraded from 2004, from B to C) (7). The 2008 guidelines also recommended against use of rhAPC in low-risk adult patients, most of whom will have APACHE II scores  $\leq 20$  or single organ failures (grade 1A), and against use in all pediatric patients (grade 1B).

The results of the PROWESS SHOCK trial (1,696 patients) were released in late 2011, showing no benefit of rhAPC in patients with septic shock (mortality 26.4% for rhAPC, 24.2% placebo) with a relative risk of 1.09 and a  $p$  value of 0.31 (231). The drug was withdrawn from the market and is no longer available, negating any need for an SSC recommendation regarding its use.

## O. Mechanical Ventilation of Sepsis-Induced Acute Respiratory Distress Syndrome

1. We recommend that clinicians target a tidal volume of 6 mL/kg predicted body weight in patients with sepsis-induced acute respiratory distress syndrome (ARDS) (grade 1A vs. 12 mL/kg).
2. We recommend that plateau pressures be measured in patients with ARDS and that the initial upper limit goal for plateau pressures in a passively inflated lung be  $\leq 30$  cm H<sub>2</sub>O (grade 1B).

**Rationale.** Of note, studies used to determine recommendations in this section enrolled patients using criteria from the American-European Consensus Criteria Definition for Acute Lung Injury (ALI) and ARDS (232). For this document, we have used the updated Berlin definition and used the terms *mild*, *moderate*, and *severe* ARDS ( $\text{PaO}_2/\text{FiO}_2 \leq 300$ ,  $\leq 200$ , and  $\leq 100$  mm Hg, respectively) for the syndromes previously known as ALI and ARDS (233). Several multicenter randomized trials have been performed in patients with established ARDS to evaluate the effects of limiting inspiratory pressure through moderation of tidal volume (234–238). These studies showed differing results that may have been caused by differences in airway pressures in the treatment and control groups (233, 234, 239). Several meta-analyses suggest decreased mortality in patients with a pressure- and volume-limited strategy for established ARDS (240, 241).

The largest trial of a volume- and pressure-limited strategy showed an absolute 9% decrease in all-cause mortality in patients with ARDS ventilated with tidal volumes of 6 mL/kg compared with 12 mL/kg of predicted body weight (PBW), and aiming for a plateau pressure  $\leq 30$  cm H<sub>2</sub>O (233). The use of lung-protective

strategies for patients with ARDS is supported by clinical trials and has been widely accepted, but the precise choice of tidal volume for an individual patient with ARDS may require adjustment for such factors as the plateau pressure achieved, the level of positive end-expiratory pressure chosen, the compliance of the thoracoabdominal compartment, and the vigor of the patient's breathing effort. Patients with profound metabolic acidosis, high obligate minute ventilations, or short stature may require additional manipulation of tidal volumes. Some clinicians believe it may be safe to ventilate with tidal volumes  $> 6$  mL/kg PBW as long as the plateau pressure can be maintained  $\leq 30$  cm H<sub>2</sub>O (242, 243). The validity of this ceiling value will depend on the patient's effort, as those who are actively breathing generate higher transalveolar pressures for a given plateau pressure than patients who are passively inflated. Conversely, patients with very stiff chest walls may require plateau pressures  $> 30$  cm H<sub>2</sub>O to meet vital clinical objectives. A retrospective study suggested that tidal volumes should be lowered even with plateau pressures  $\leq 30$  cm H<sub>2</sub>O (244) as lower plateau pressures were associated with decreased in-hospital mortality (245).

High tidal volumes that are coupled with high plateau pressures should be avoided in ARDS. Clinicians should use as a starting point the objective of reducing tidal volume over 1 to 2 hrs from its initial value toward the goal of a "low" tidal volume ( $\approx 6$  mL/kg PBW) achieved in conjunction with an end-inspiratory plateau pressure  $\leq 30$  cm H<sub>2</sub>O. If the plateau pressure remains  $> 30$  cm H<sub>2</sub>O after reduction of tidal volume to 6 mL/kg PBW, tidal volume may be reduced further to as low as 4 mL/kg PBW per protocol. (**Appendix C** provides ARDSNet ventilator management and formulas to calculate PBW.) Using volume- and pressure-limited ventilation may lead to hypercapnia with maximum tolerated set respiratory rates. In such cases, hypercapnia that is otherwise not contraindicated (eg, high intracranial pressure) and appears to be tolerated should be allowed. Sodium bicarbonate or tromethamine (THAM) infusion may be considered in selected patients to facilitate use of limited ventilator conditions that result in permissive hypercapnia (246, 247).

A number of observational trials in mechanically ventilated patients have demonstrated a decreased risk of developing ARDS when smaller tidal volumes are used (248–251). Accordingly, high tidal volumes and plateau pressures should be avoided in mechanically ventilated patients at risk for developing ARDS, including those with sepsis.

No single mode of ventilation (pressure control, volume control) has consistently been shown to be advantageous when compared with any other that respects the same principles of lung protection.

3. We recommend that positive end-expiratory pressure (PEEP) be applied to avoid alveolar collapse at end expiration (atelectotrauma) (grade 1B).
4. We suggest strategies based on higher rather than lower levels of PEEP for patients with sepsis-induced moderate to severe ARDS (grade 2C).

**Rationale.** Raising PEEP in ARDS keeps lung units open to participate in gas exchange. This will increase PaO<sub>2</sub> when PEEP is applied through either an endotracheal tube or a face mask (252–254). In animal experiments, avoidance of end-expiratory alveolar collapse helps minimize ventilator-induced lung injury when relatively high plateau pressures are in use. Three large multicenter trials using higher vs. lower levels of PEEP in conjunction with low tidal volumes did not uncover benefit or harm (255–257). A meta-analysis using individual patient data showed no benefit in all patients with ARDS; however, patients with moderate or severe ARDS (PaO<sub>2</sub>/Fio<sub>2</sub> ratio  $\leq 200$  mm Hg) had decreased mortality with the use of higher PEEP, whereas those with mild ARDS did not (258). Two options are recommended for PEEP titration. One option is to titrate PEEP (and tidal volume) according to bedside measurements of thoracopulmonary compliance with the objective of obtaining the best compliance, reflecting a favorable balance of lung recruitment and overdistension (259). The second option is to titrate PEEP based on severity of oxygenation deficit and guided by the Fio<sub>2</sub> required to maintain adequate oxygenation (234, 255, 256). A PEEP  $> 5$  cm H<sub>2</sub>O is usually required to avoid lung collapse (260). The ARDSNet standard PEEP strategy is shown in Appendix C. The higher PEEP strategy recommended for ARDS is shown in **Appendix D** and comes from the ALVEOLI trial (257).

5. We suggest recruitment maneuvers in sepsis patients with severe refractory hypoxemia due to ARDS (grade 2C).
6. We suggest prone positioning in sepsis-induced ARDS patients with a PaO<sub>2</sub>/Fio<sub>2</sub> ratio  $\leq 100$  mm Hg in facilities that have experience with such practices (grade 2B).

**Rationale.** Many strategies exist for treating refractory hypoxemia in patients with severe ARDS (261). Temporarily raising transpulmonary pressure may facilitate opening atelectatic alveoli to permit gas exchange (260), but could also overdistend aerated lung units leading to ventilator-induced lung injury and temporary hypotension. The application of transient sustained use of continuous positive airway pressure appears to improve oxygenation in patients initially, but these effects can be transient (262). Although selected patients with severe hypoxemia may benefit from recruitment maneuvers in conjunction with higher levels of PEEP, little evidence supports the routine use in all ARDS patients (262). Blood pressure and oxygenation should be monitored and recruitment maneuvers discontinued if deterioration in these variables is observed.

Several small studies and one large study in patients with hypoxemic respiratory failure or ARDS have shown that most patients respond to the prone position with improved oxygenation (263–266). None of the individual trials of prone positioning in patients with ARDS or hypoxemic respiratory failure demonstrated a mortality benefit (267–270). One meta-analysis suggested potential benefits for prone positioning in patients with profound hypoxemia and PaO<sub>2</sub>/Fio<sub>2</sub> ratio  $\leq 100$  mm Hg, but not in those with less severe hypoxemia (270). Prone positioning may be associated with potentially life-threatening complications, including accidental dislodging of the endotracheal

and chest tubes; these complications occur more frequently in patients in the prone compared with supine position (270).

Other methods to treat refractory hypoxemia, including high-frequency oscillatory ventilation, airway pressure release ventilation, and extracorporeal membrane oxygenation (271), may be considered as rescue therapies in centers with expertise and experience with their use (261, 271–274). Inhaled nitric oxide does not improve mortality rates in patients with ARDS and should not be routinely used (275).

7. We recommend that mechanically ventilated sepsis patients be maintained with the head of the bed elevated between 30 and 45 degrees to limit aspiration risk and to prevent the development of VAP (grade 1B).

**Rationale.** The semi-recumbent position has been demonstrated to decrease the incidence of VAP (276). Enteral feeding increased the risk of developing VAP; 50% of the patients who were fed enterally in the supine position developed VAP compared with 9% of those fed in the semi-recumbent position (276). However, the bed position was monitored only once a day, and patients who did not achieve the desired bed elevation were not included in the analysis (276). One study did not show a difference in incidence of VAP between patients maintained in supine and semi-recumbent positions (277); patients assigned to the semi-recumbent group did not consistently achieve the desired head of the bed elevation, and the head of bed elevation in the supine group approached that of the semi-recumbent group by day 7 (277). When necessary, patients may be laid flat for procedures, hemodynamic measurements, and during episodes of hypotension. Patients should not be fed enterally while supine.

8. We suggest that noninvasive mask ventilation (NIV) be used in that minority of sepsis-induced ARDS patients in whom the benefits of NIV have been carefully considered and are thought to outweigh the risks (grade 2B).

**Rationale.** Obviating the need for airway intubation confers multiple advantages: better communication, lower incidence of infection, and reduced requirements for sedation. Two RCTs in patients with acute respiratory failure demonstrated improved outcome with the use of NIV when it can be used successfully (278, 279). Unfortunately, only a small percentage of sepsis patients with life-threatening hypoxemia can be managed in this way (280, 281).

NIV should be considered in patients with sepsis-induced ARDS if they are responsive to relatively low levels of pressure support and PEEP with stable hemodynamics, can be made comfortable, and are easily arousable; if they are able to protect the airway and spontaneously clear the airway of secretions; and if they are anticipated to recover rapidly from the precipitating insult (280, 281). A low threshold for airway intubation should be maintained.

9. We recommend that a weaning protocol be in place and that mechanically ventilated patients with severe sepsis undergo spontaneous breathing trials regularly to evaluate the ability to discontinue mechanical ventilation when they satisfy the

following criteria: a) arousable; b) hemodynamically stable (without vasopressor agents); c) no new potentially serious conditions; d) low ventilatory and end-expiratory pressure requirements; and e) low  $F_{IO_2}$  requirements which can be safely delivered with a face mask or nasal cannula. If the spontaneous breathing trial is successful, extubation should be considered (grade 1A).

**Rationale.** Spontaneous breathing trial options include a low level of pressure support, continuous positive airway pressure ( $\approx 5$  cm  $H_2O$ ), or a use of a T-piece. Studies demonstrated that daily spontaneous breathing trials in appropriately selected patients reduce the duration of mechanical ventilation (282, 283). These breathing trials should be conducted in conjunction with a spontaneous awakening trial (284). Successful completion of spontaneous breathing trials leads to a high likelihood of successful early discontinuation of mechanical ventilation.

10. We recommend against the routine use of the pulmonary artery catheter for patients with sepsis-induced ARDS (grade 1A).

**Rationale.** Although insertion of a pulmonary artery (PA) catheter may provide useful information on a patient's volume status and cardiac function, these benefits may be confounded by differences in the interpretation of results (285–287), lack of correlation of PA occlusion pressures with clinical response (288), and an absence of a proven strategy to use catheter results to improve patient outcomes (173). Two multicenter randomized trials, one in patients with shock or ARDS (289) and the other in those with only ARDS (290), failed to show benefit with the routine use of PA catheters in ARDS. In addition, other studies in different types of critically ill patients have failed to show definitive benefit with routine use of the PA catheter (291–293). Well-selected patients remain appropriate candidates for PA catheter insertion only when the answers to important management decisions depend on information solely obtainable from direct measurements made within the PA (292, 294).

11. We recommend a conservative fluid strategy for patients with established sepsis-induced ARDS who do not have evidence of tissue hypoperfusion (grade 1C).

**Rationale.** Mechanisms for the development of pulmonary edema in patients with ARDS include increased capillary permeability, increased hydrostatic pressure, and decreased oncotic pressure (295). Small prospective studies in patients with critical illness and ARDS have suggested that low weight gain is associated with improved oxygenation (296) and fewer days of mechanical ventilation (297, 298). A fluid-conservative strategy to minimize fluid infusion and weight gain in patients with ARDS, based on either a central venous catheter (CVP  $< 4$  mm Hg) or a PA catheter (pulmonary artery wedge pressure  $< 8$  mm Hg), along with clinical variables to guide treatment, led to fewer days of mechanical ventilation and reduced length of ICU stay without altering the incidence of renal failure or mortality rates (299). This strategy was only used in patients



with established ARDS, some of whom had shock present during the ICU stay, and active attempts to reduce fluid volume were conducted only outside periods of shock.

12. In the absence of specific indications such as bronchospasm, we recommend against the use of  $\beta_2$ -agonists for treatment of patients with sepsis-induced ARDS (grade 1B).

**Rationale.** Patients with sepsis-induced ARDS often develop increased vascular permeability. Preclinical and early clinical data suggest that  $\beta$ -adrenergic agonists may speed resorption of alveolar edema (300). Two randomized clinical trials studied the effect of  $\beta$ -agonists in patients with ARDS (301, 302). In one, a comparison of aerosolized albuterol and placebo in 282 patients with ARDS, the trial was stopped for futility (301). Patients receiving albuterol had higher heart rates on day 2, and a trend was detected toward decreased ventilator-free days (days alive and off the ventilator). The rates of death before discharge were 23.0% in the albuterol group vs. 17.7% in placebo-treated patients. More than half of the patients enrolled in this trial had pulmonary or nonpulmonary sepsis as the cause of the ARDS (301).

The use of intravenous salbutamol was tested in the BALTI-2 trial (302). Three hundred twenty-six patients with ARDS, 251 of whom had pulmonary or nonpulmonary sepsis as cause, were randomized to intravenous salbutamol, 15  $\mu$ g/kg of ideal body weight, or placebo for up to 7 days. Patients treated with salbutamol had increased 28-day mortality rates (34% vs. 23%; RR, 1.4; 95% CI, 1.03–2.08) leading to early termination of the trial (302).

Beta-2 agonists may have specific indications, such as treatment of bronchospasm and hyperkalemia. In the absence of these conditions, we recommend against the routine use of  $\beta$ -agonists, either in intravenous or aerosolized form, for the treatment of patients with sepsis-induced ARDS.

## P. Sedation, Analgesia, and Neuromuscular Blockade in Sepsis

1. We recommend that either continuous or intermittent sedation be minimized in mechanically ventilated sepsis patients, targeting specific titration endpoints (grade 1B).

**Rationale.** A growing body of evidence indicates that limiting the use of sedation in critically ill ventilated patients can reduce the duration of mechanical ventilation and ICU and hospital lengths of stay (303–305). While studies limiting sedation have been performed in a wide range of critically ill patients, there is little reason to assume that septic patients will not derive benefit from this approach (305). The use of protocols for sedation is one method to limit sedation use, and a randomized, controlled clinical trial found that protocolized sedation compared with usual care reduced duration of mechanical ventilation, lengths of stay, and tracheostomy rates (305). Avoidance of sedation is another strategy. A recent observational study of 250 critically ill patients suggests that deep sedation is common in mechanically ventilated patients (306). A randomized, controlled clinical trial found that patients treated with intravenous morphine boluses

preferentially had significantly more days without ventilation, shorter stay in ICU and hospital, than patients who received sedation (propofol and midazolam) in addition to morphine (307). However, agitated delirium was more frequently detected in the intervention group. Although not specifically studied in patients with sepsis, the administration of intermittent sedation, daily sedative interruption, and systematic titration to a predefined endpoint have been demonstrated to decrease the duration of mechanical ventilation (284, 305, 308, 309). Patients receiving neuromuscular blocking agents (NMBAs) must be individually assessed regarding discontinuation of sedative drugs because the neuromuscular blockade must first be reversed. The use of intermittent vs. continuous methods for the delivery of sedation in critically ill patients has been examined in an observational study of mechanically ventilated patients that showed that patients receiving continuous sedation had significantly longer durations of mechanical ventilation and ICU and hospital lengths of stay (310).

Clinical trials have evaluated daily interruption of continuous sedative infusions. A prospective, randomized controlled trial in 128 mechanically ventilated adults receiving continuous intravenous sedation demonstrated that a daily interruption in the continuous sedative infusion until the patient was awake decreased the duration of mechanical ventilation and ICU length of stay (283). Although the patients did receive continuous sedative infusions in this study, the daily interruption and awakening allowed for titration of sedation, in effect making the dosing intermittent. In addition, a paired spontaneous awakening trial combined with a spontaneous breathing trial decreased the duration of mechanical ventilation, length of ICU and hospital stay, and 1-year mortality (284). More recently, a multicenter randomized trial compared protocolized sedation with protocolized sedation plus daily sedation interruption in 423 critically ill mechanically ventilated medical and surgical patients (311). There were no differences in duration of mechanical ventilation or lengths of stay between the groups; and daily interruption was associated with higher daily opioid and benzodiazepines doses, as well as higher nurse workload. Additionally, a randomized prospective blinded observational study demonstrated that although myocardial ischemia is common in critically ill ventilated patients, daily sedative interruption is not associated with an increased occurrence of myocardial ischemia (312). Regardless of sedation approach, early physical rehabilitation should be a goal (313).

2. We recommend that NMBAs be avoided if possible in the septic patient *without* ARDS due to the risk of prolonged neuromuscular blockade following discontinuation. If NMBAs must be maintained, either intermittent bolus as required or continuous infusion with train-of-four monitoring of the depth of blockade should be used (grade 1C).
3. We suggest a short course of an NMBA ( $\leq$  48 hours) for patients *with* early, sepsis-induced ARDS and  $P_{aO_2}/F_{iO_2} < 150$  mm Hg (grade 2C).

**Rationale.** Although NMBA are often administered to critically ill patients, their role in the ICU is not well defined. No evidence exists that neuromuscular blockade in this patient population reduces mortality or major morbidity. In addition, no studies have been published that specifically address the use of NMBA in septic patients.

The most common indication for NMBA use in the ICU is to facilitate mechanical ventilation (314). When appropriately used, these agents may improve chest wall compliance, prevent respiratory dyssynchrony, and reduce peak airway pressures (315). Muscle paralysis may also reduce oxygen consumption by decreasing the work of breathing and respiratory muscle blood flow (316). However, a randomized, placebo-controlled clinical trial in patients with severe sepsis demonstrated that oxygen delivery, oxygen consumption, and gastric intramucosal pH were not improved during deep neuromuscular blockade (317).

A recent randomized clinical trial of continuous infusions of cisatracurium in patients with early ARDS and a  $\text{PaO}_2/\text{FIO}_2 < 150$  mm Hg showed improved adjusted survival rates and more organ failure-free days without an increased risk in ICU-acquired weakness compared with placebo-treated patients (318). The investigators used a high fixed dose of cisatracurium without train-of-four monitoring, and half of the patients in the placebo group received at least a single dose of NMBA. Whether another NMBA would have similar effects is unknown. Although many of the patients enrolled into this trial appeared to meet sepsis criteria, it is not clear whether similar results would occur in sepsis patients. A GRADEpro Summary of Evidence Table regarding use of NMBA in ARDS appears in **Supplemental Digital Content 5** (<http://links.lww.com/CCM/A615>).

An association between NMBA use and myopathies and neuropathies has been suggested by case studies and prospective observational studies in the critical care population (315, 319–322), but the mechanisms by which NMBA produce or contribute to myopathies and neuropathies in these patients are unknown. Although no studies are specific to the septic patient population, it seems clinically prudent, based on existing knowledge, that NMBA not be administered unless there is a clear indication for neuromuscular blockade that cannot be safely achieved with appropriate sedation and analgesia (315).

Only one prospective RCT has compared peripheral nerve stimulation and standard clinical assessment in ICU patients. Rudis et al (323) randomized 77 critically ill ICU patients requiring neuromuscular blockade to receive dosing of vecuronium based on train-of-four stimulation or on clinical assessment (control group). The peripheral nerve stimulation group received less drug and recovered neuromuscular function and spontaneous ventilation faster than the control group. Nonrandomized observational studies have suggested that peripheral nerve monitoring reduces or has no effect on clinical recovery from NMBA in the ICU (324, 325).

Benefits to neuromuscular monitoring, including faster recovery of neuromuscular function and shorter intubation times, appear to exist. A potential for cost savings (reduced

total dose of NMBA and shorter intubation times) also may exist, although this has not been studied formally.

## Q. Glucose Control

1. We recommend a protocolized approach to blood glucose management in ICU patients with severe sepsis, commencing insulin dosing when two consecutive blood glucose levels are  $> 180$  mg/dL. This approach should target an upper blood glucose level  $\leq 180$  mg/dL rather than an upper target blood glucose  $\leq 110$  mg/dL (grade 1A).
2. We recommend blood glucose values be monitored every 1 to 2 hrs until glucose values and insulin infusion rates are stable, then every 4 hrs thereafter (grade 1C).
3. We recommend that glucose levels obtained with point-of-care testing of capillary blood be interpreted with caution, as such measurements may not accurately estimate arterial blood or plasma glucose values (UG).

**Rationale.** One large RCT single-center trial in a predominantly cardiac surgical ICU demonstrated a reduction in ICU mortality with intensive intravenous insulin (Leuven protocol) targeting blood glucose to 80 to 110 mg/dL (326). A second randomized trial of intensive insulin therapy using the Leuven protocol enrolled medical ICU patients with an anticipated ICU length of stay of more than 3 days in three medical ICUs and overall mortality was not reduced (327).

Since these studies (326, 327) and the previous Surviving Sepsis Guidelines (7) appeared, several RCTs (128, 328–332) and meta-analyses (333–337) of intensive insulin therapy have been performed. The RCTs studied mixed populations of surgical and medical ICU patients (128, 328–332) and found that intensive insulin therapy did not significantly decrease mortality (128, 328–332), whereas the NICE-SUGAR trial demonstrated an increased mortality (331). All studies (128, 326–332) reported a much higher incidence of severe hypoglycemia (glucose  $\leq 40$  mg/dL) (6%–29%) with intensive insulin therapy. Several meta-analyses confirmed that intensive insulin therapy was not associated with a mortality benefit in surgical, medical, or mixed ICU patients (333, 335, 337). The meta-analysis by Griesdale and colleagues (334), using between-trial comparisons driven mainly by the 2001 study by van den Berghe et al (326), found that intensive insulin therapy was beneficial in surgical ICU patients (risk ratio, 0.63 [0.44–0.9]), whereas the meta-analysis by Friedrich et al (336), using within-trial comparisons, showed no benefit for surgical patients in mixed medical-surgical ICUs (risk ratio 0.99 [0.82–1.11]) and no subgroup of surgical patients who benefited from intensive insulin therapy. Interestingly, the RCTs that reported (326, 327) compared intensive insulin therapy to high controls (180–200 mg/dL) (OR, 0.89 [0.73–1.09]), whereas those that did not demonstrate benefit (330–332) compared intensive therapy to moderate controls (108–180 mg/dL) [OR, 1.14 (1.02 to –1.26)]. See **Supplemental Digital Content 6** (<http://links.lww.com/CCM/A615>) for details.

The trigger to start an insulin protocol for blood glucose levels  $> 180$  mg/dL with an upper target blood glucose level  $< 180$  mg/dL derives from the NICE-SUGAR study (331), which used these values for initiating and stopping therapy. The

NICE-SUGAR trial is the largest, most compelling study to date on glucose control in ICU patients given its inclusion of multiple ICUs and hospitals and a general patient population. Several medical organizations, including the American Association of Clinical Endocrinologists, American Diabetes Association, American Heart Association, American College of Physicians, and Society of Critical Care Medicine, have published consensus statements for glycemic control of hospitalized patients (338–341). These statements usually targeted glucose levels between 140 and 180 mg/dL. As there is no evidence that targets between 140 and 180 mg/dL are different from targets of 110 to 140 mg/dL, the recommendations use an upper target blood glucose  $\leq$  180 mg/dL without a lower target other than hypoglycemia. Treatment should avoid hyperglycemia ( $>$  180 mg/dL), hypoglycemia, and wide swings in glucose levels. The continuation of insulin infusions, especially with the cessation of nutrition, has been identified as a risk factor for hypoglycemia (332). Balanced nutrition may be associated with a reduced risk of hypoglycemia (342). Several studies have suggested that the variability in glucose levels over time is an important determinant of mortality (343–345). Hyperglycemia and glucose variability seem to be unassociated with increased mortality rates in diabetic patients compared to nondiabetic patients (346, 347).

Several factors may affect the accuracy and reproducibility of point-of-care testing of blood capillary blood glucose, including the type and model of the device used, user expertise, and patient factors, including hematocrit (false elevation with anemia),  $\text{PaO}_2$ , and drugs (348). Plasma glucose values by capillary point-of-care testing have been found to be inaccurate with frequent false elevations (349, 350) over the range of glucose levels (350), but especially in the hypoglycemic (349, 351) and hyperglycemic ranges (351) and in hypotensive patients (352) or patients receiving catecholamines (353). A review of 12 published insulin infusion protocols for critically ill patients showed wide variability in dose recommendations and variable glucose control (354). This lack of consensus about optimal dosing of intravenous insulin may reflect variability in patient factors (severity of illness, surgical vs. medical settings), or practice patterns (eg, approaches to feeding, intravenous dextrose) in the environments in which these protocols were developed and tested. Alternatively, some protocols may be more effective than others, conclusion supported by the wide variability in hypoglycemia rates reported with protocols (128, 326–333). Thus, the use of established insulin protocols is important not only for clinical care but also for the conduct of clinical trials to avoid hypoglycemia, adverse events, and premature termination of trials before the efficacy signal, if any, can be determined. Several studies have suggested that computer-based algorithms result in tighter glycemic control with a reduced risk of hypoglycemia (355, 356). Further study of validated, safe, and effective protocols for controlling blood glucose concentrations and variability in the severe sepsis population is needed.

## R. Renal Replacement Therapy

1. We suggest that continuous renal replacement therapies and intermittent hemodialysis are equivalent in patients with

severe sepsis and acute renal failure because they achieve similar short-term survival rates (grade 2B).

2. We suggest the use of continuous therapies to facilitate management of fluid balance in hemodynamically unstable septic patients (grade 2D).

**Rationale.** Although numerous nonrandomized studies have reported a nonsignificant trend toward improved survival using continuous methods (357–364), two meta-analyses (365, 366) reported the absence of significant difference in hospital mortality between patients who receive continuous and intermittent renal replacement therapies. This absence of apparent benefit of one modality over the other persists even when the analysis is restricted to RCT studies (366). To date, five prospective RCTs have been published (367–371); four found no significant difference in mortality (368–371), whereas one found significantly higher mortality in the continuous treatment group (367), but imbalanced randomization had led to a higher baseline severity of illness in this group. When a multivariable model was used to adjust for severity of illness, no difference in mortality was apparent between the groups (367). Most studies comparing modes of renal replacement in the critically ill have included a small number of patients and some major weaknesses (ie, randomization failure, modifications of therapeutic protocol during the study period, combination of different types of continuous renal replacement therapies, small number of heterogeneous groups of enrollees). The most recent and largest RCT (371) enrolled 360 patients and found no significant difference in survival between the continuous and intermittent groups. Moreover, no evidence supports the use of continuous therapies in sepsis independent of renal replacement needs.

No evidence supports a better tolerance with continuous treatments regarding the hemodynamic tolerance of each method. Two prospective studies (369, 372) have reported a better hemodynamic tolerance with continuous treatment, with no improvement in regional perfusion (372) and no survival benefit (369). Four other prospective studies did not find any significant difference in mean arterial pressure or drop in systolic pressure between the two methods (368, 370, 371, 373). Two studies reported a significant improvement in goal achievement with continuous methods (367, 369) regarding fluid balance management. In summary, the evidence is insufficient to draw strong conclusions regarding the mode of replacement therapy for acute renal failure in septic patients.

The effect of dose of continuous renal replacement on outcomes in patients with acute renal failure has shown mixed results (374, 375). None of these trials was conducted specifically in patients with sepsis. Although the weight of evidence suggests that higher doses of renal replacement may be associated with improved outcomes, these results may not be generalizable. Two large multicenter randomized trials comparing the dose of renal replacement (Acute Renal Failure Trial Network in the United States and RENAL Renal Replacement Therapy Study in Australia and New Zealand) failed to show benefit of more aggressive renal replacement dosing. (376, 377). A typical



dose for continuous renal replacement therapy would be 20 to 25 mL/kg/hr of effluent generation.

## S. Bicarbonate Therapy

1. We recommend against the use of sodium bicarbonate therapy for the purpose of improving hemodynamics or reducing vasopressor requirements in patients with hypoperfusion-induced lactic acidemia with  $\text{pH} \geq 7.15$  (grade 2B).

**Rationale.** Although bicarbonate therapy may be useful in limiting tidal volume in ARDS in some situations of permissive hypercapnia (see section, Mechanical Ventilation of ARDS), no evidence supports the use of bicarbonate therapy in the treatment of hypoperfusion-induced lactic acidemia associated with sepsis. Two blinded, crossover RCTs that compared equimolar saline and bicarbonate in patients with lactic acidosis failed to reveal any difference in hemodynamic variables or vasopressor requirements (378, 379). The number of patients with  $< 7.15$  pH in these studies was small. Bicarbonate administration has been associated with sodium and fluid overload, an increase in lactate and  $\text{Pco}_2$ , and a decrease in serum ionized calcium, but the relevance of these variables to outcome is uncertain. The effect of bicarbonate administration on hemodynamics and vasopressor requirements at lower pH, as well as the effect on clinical outcomes at any pH, is unknown. No studies have examined the effect of bicarbonate administration on outcomes.

## T. Deep Vein Thrombosis Prophylaxis

1. We recommend that patients with severe sepsis receive daily pharmacoprophylaxis against venous thromboembolism (VTE) (grade 1B). We recommend that this be accomplished with daily subcutaneous low-molecular weight heparin (LMWH) (grade 1B versus unfractionated heparin [UFH] twice daily and grade 2C versus UFH given thrice daily). If creatinine clearance is  $< 30$  mL/min, we recommend use of dalteparin (grade 1A) or another form of LMWH that has a low degree of renal metabolism (grade 2C) or UFH (grade 1A).
2. We suggest that patients with severe sepsis be treated with a combination of pharmacologic therapy and intermittent pneumatic compression devices whenever possible (grade 2C).
3. We recommend that septic patients who have a contraindication to heparin use (eg, thrombocytopenia, severe coagulopathy, active bleeding, recent intracerebral hemorrhage) not receive pharmacoprophylaxis (grade 1B). Rather we suggest they receive mechanical prophylactic treatment, such as graduated compression stockings or intermittent compression devices (grade 2C), unless contraindicated. When the risk decreases, we suggest starting pharmacoprophylaxis (grade 2C).

**Rationale.** ICU patients are at risk for deep vein thrombosis (DVT) (380). It is logical that patients with severe sepsis would be at a similar or higher risk than the general ICU population. The consequences of VTE in the setting of sepsis (increased risk of potentially fatal pulmonary emboli in an already

hemodynamically compromised patient) are dire. Therefore, prevention of VTE is highly desirable, especially if it can be done safely and effectively.

Prophylaxis is generally effective. In particular, nine placebo-controlled RCTs of VTE prophylaxis have been conducted in general populations of acutely ill patients (381–389). All trials showed reduction in DVT or pulmonary embolism, a benefit that is also supported by meta-analyses (390, 391). Thus, the evidence strongly supports the value of VTE prophylaxis (grade 1A). The prevalence of infection/sepsis was 17% in those studies in which this could be ascertained. One study investigated only ICU patients only, and 52% of those enrolled had infection/sepsis. The need to extrapolate from general, acutely ill patients to critically ill patients to septic patients downgrades the evidence. That the effect is pronounced and the data are robust somewhat mitigate against the extrapolation, leading to a grade B determination. Because the patient's risk of administration is small, the gravity of not administering may be great, and the cost is low, the strength of the recommendation is strong (1).

Deciding how to provide prophylaxis is decidedly more difficult. The Canadian Critical Care Trials Group compared UFH (5000 IU twice daily) to LMWH (dalteparin, 5000 IU once per day and a second placebo injection to ensure parallel-group equivalence) (392). No statistically significant difference in asymptomatic DVTs was found between the two groups (hazard ratio, 0.92; 95% CI, 0.68–1.23;  $p = 0.57$ ), but the proportion of patients diagnosed with pulmonary embolism on CT scan, high-probability ventilation perfusion scan, or autopsy was significantly lower in the LMWH group (hazard ratio, 0.51; 95% CI, 0.30–0.88;  $p = 0.01$ ). The study did not account for the use of other forms of LMWH. These data suggest that LMWH (dalteparin) is the treatment of choice over UFH administered twice daily in critically ill patients. Also, because the study included septic patients, the evidence supporting the use of dalteparin over twice daily UFH in critically ill, and perhaps septic, patients is strong. Similarly, a meta-analysis of acutely ill, general medical patients comparing UFH twice and thrice daily demonstrated that the latter regimen was more effective at preventing VTE, but twice daily dosing produced less bleeding (393). Both critically ill and septic patients were included in these analyses, but their numbers are unclear. Nonetheless, the quality of evidence supporting the use of three times daily, as opposed to twice daily, UFH dosing in preventing VTE in acutely ill medical patients is high (A). However, comparing LMWH to twice daily UFH, or twice daily UFH to three times daily UFH, in sepsis requires extrapolation, downgrading the data. No data exist on direct comparison of LMWH to UFH administered three times daily, nor are there any studies directly comparing twice daily and thrice daily UFH dosing in septic or critically ill patients. Therefore, it is not possible to state that LMWH is superior to three times daily UFH or that three times daily dosing is superior to twice daily administration in sepsis. This downgrades the quality of the evidence and therefore the recommendation.

Douketis et al (394) conducted a study of 120 critically ill patients with acute kidney injury (creatinine clearance

< 30 mL/min) who received VTE prophylaxis with dalteparin 5000 IU daily for between 4 and 14 days and had at least one trough anti-factor Xa level measured. None of the patients had bio-accumulation (trough anti-factor Xa level lower than 0.06 IU/mL). The incidence of major bleeding was somewhat higher than in trials of other agents, but most other studies did not involve critically ill patients, in whom the bleeding risk is higher. Further, bleeding did not correlate with detectable trough levels (394). Therefore, we recommend that dalteparin can be administered to critically ill patients with acute renal failure (A). Data on other LMWHs are lacking. Consequently, these forms should probably be avoided or, if used, anti-factor Xa levels should be monitored (grade 2C). UFH is not renally cleared and is safe (grade 1A).

Mechanical methods (intermittent compression devices and graduated compression stockings) are recommended when anticoagulation is contraindicated (395–397). A meta-analysis of 11 studies, including six RCTs, published in the Cochrane Library concluded that the combination of pharmacologic and mechanical prophylaxis was superior to either modality alone in preventing DVT and was better than compression alone in preventing pulmonary embolism (398). This analysis did not focus on sepsis or critically ill patients but included studies of prophylaxis after orthopedic, pelvic, and cardiac surgery. In addition, the type of pharmacologic prophylaxis varied, including UFH, LMWH, aspirin, and warfarin. Nonetheless, the minimal risk associated with compression devices lead us to recommend combination therapy in most cases. In very-high-risk patients, LMWH is preferred over UFH (392, 399–401). Patients receiving heparin should be monitored for development of heparin-induced thrombocytopenia. These recommendations are consistent with those developed by the American College of Chest Physicians (402).

## U. Stress Ulcer Prophylaxis

1. We recommend that stress ulcer prophylaxis using H<sub>2</sub> blocker or proton pump inhibitor be given to patients with severe sepsis/septic shock who have bleeding risk factors (grade 1B).
2. When stress ulcer prophylaxis is used, we suggest the use of proton pump inhibitors rather than H<sub>2</sub> receptor antagonists (H2RA) (grade 2C).
3. We suggest that patients without risk factors should not receive prophylaxis (grade 2B).

**Rationale.** Although no study has been performed specifically in patients with severe sepsis, trials confirming the benefit of stress ulcer prophylaxis in reducing upper gastrointestinal (GI) bleeding in general ICU populations included 20% to 25% of patients with sepsis (403–406). This benefit should be applicable to patients with severe sepsis and septic shock. In addition, the risk factors for GI bleeding (eg, coagulopathy, mechanical ventilation for at least 48 hrs, possibly hypotension) are frequently present in patients with severe sepsis and septic shock (407, 408). Patients without these risk factors are unlikely (0.2%; 95% CI, 0.02–0.5) to have clinically important bleeding (407).

Both old and new meta-analyses show prophylaxis-induced reduction in clinically significant upper GI bleeding, which we consider significant even in the absence of proven mortality benefit (409–411). The benefit of prevention of upper GI bleeding must be weighed against the potential (unproven) effect of increased stomach pH on a greater incidence of VAP and *C. difficile* infection (409, 412, 413). (See **Supplemental Digital Content 7 and 8** [<http://links.lww.com/CCM/A615>], Summary of Evidence Tables for effects of treatments on specific outcomes.) In an exploratory hypothesis, we considered (as did the authors of the meta-analysis) (411) the possibility of less benefit and more harm in prophylaxis among patients receiving enteral nutrition but decided to provide one recommendation while lowering the quality of evidence. The balance of benefits and risks may thus depend on the individual patient's characteristics as well as on the local epidemiology of VAP and *C. difficile* infections. The rationale for considering only suppression of acid production (and not sucralfate) is based on the study of 1,200 patients by Cook et al comparing H<sub>2</sub> blockers and sucralfate (414). More recent meta-analyses provide low-quality evidence suggesting more effective GI bleeding protection with the use of proton pump inhibitors than with H2RA (415–417). Patients should be periodically evaluated for the continued need for prophylaxis.

## V. Nutrition

1. We suggest administering oral or enteral (if necessary) feedings, as tolerated, rather than either complete fasting or provision of only intravenous glucose within the first 48 hrs after a diagnosis of severe sepsis/septic shock (grade 2C).
2. We suggest avoiding mandatory full caloric feeding in the first week, but rather suggest low-dose feeding (eg, up to 500 kcal per day), advancing only as tolerated (grade 2B).
3. We suggest using intravenous glucose and enteral nutrition rather than total parenteral nutrition (TPN) alone or parenteral nutrition in conjunction with enteral feeding in the first 7 days after a diagnosis of severe sepsis/septic shock (grade 2B).
4. We suggest using nutrition with no specific immunomodulating supplementation in patients with severe sepsis (grade 2C).

**Rationale.** Early enteral nutrition has theoretical advantages in the integrity of gut mucosa and prevention of bacterial translocation and organ dysfunction, but also concerning is the risk of ischemia, mainly in hemodynamically unstable patients.

Unfortunately, no clinical trial has specifically addressed early feeding in septic patients. Studies on different subpopulations of critically ill patients, mostly surgical patients, are not consistent, with great variability in the intervention and control groups; all are of low methodological quality (418–427) and none was individually powered for mortality, with very low mortality rates (418–420, 423, 426). Authors of previously published meta-analyses of optimal nutrition strategies for the critically ill all reported that the studies they included had high heterogeneity and low quality (418–430). Although no consistent effect on mortality was observed, there was evidence of benefit from some early enteral feeding on secondary outcomes,



such as reduced incidence of infectious complications (418, 422, 426, 427–430), reduced length of mechanical ventilation (421, 427), and reduced ICU (421, 427) and hospital stays (428). No evidence of harm was demonstrated in any of those studies. Therefore, there is insufficient evidence to issue a strong recommendation, but the suggestion of benefit and absence of harm supports a suggestion that some enteral feeding is warranted.

Studies comparing full caloric early enteral feeding to lower targets in the critically ill have produced inconclusive results. In four studies, no effect on mortality was seen (431–434); one reported fewer infectious complications (431), and the others reported increased diarrhea and gastric residuals (433, 434) and increased incidence of infectious complications with full caloric feeding (432). In another study, mortality was greater with higher feeding, but differences in feeding strategies were modest and the sample size was small (435). Therefore, evidence is insufficient to support an early target of full caloric intake and, indeed, some possibility of harm exists. Underfeeding (60%–70% of target) or trophic feeding (upper limit of 500 kcal) is probably a better nutritional strategy in the first week of severe sepsis/septic shock. This upper limit for trophic feeding is a somewhat arbitrary number, but based in part on the fact that the two recent studies used a range of 240–480 kcal (433, 434). Underfeeding/trophic feeding strategies did not exclude advancing diet as tolerated in those who improved quickly.

Some form of parenteral nutrition has been compared to alternative feeding strategies (eg, fasting or enteral nutrition) in well over 50 studies, although only one exclusively studied sepsis (436), and eight meta-analyses have been published (429, 437–443). Two of the meta-analyses summarize comparisons of parenteral nutrition vs. fasting or intravenous glucose (437, 438), and six look at parenteral vs. enteral nutrition (429, 439–443), two of which attempted to explore the effect of early enteral nutrition (441, 442). Recently, a study much larger than most earlier nutrition trials compared ICU patients randomized to early use of parenteral nutrition to augment enteral feeding vs. enteral feeding with only late initiation of parenteral nutrition if necessary (444).

No direct evidence supports the benefits or harm of parenteral nutrition in the first 48 hrs in sepsis. Rather, the evidence is generated predominantly from surgical, burn, and trauma patients. None of the meta-analyses reports a mortality benefit with parenteral nutrition, except one suggesting parenteral nutrition may be better than late introduction of enteral nutrition (442). Several suggested that parenteral nutrition had higher infectious complications compared both to fasting or intravenous glucose and to enteral nutrition (429, 431, 438, 439, 442). Enteral feeding was associated with a higher rate of enteral complications (eg, diarrhea) than parenteral nutrition (438). The use of parenteral nutrition to supplement enteral feeding was also analyzed by Dhaliwal et al (440), who also reported no benefit. The trial by Casaer et al (444) reported that early initiation of parenteral nutrition led to longer hospital and ICU stays, longer duration of organ support, and higher incidence of ICU-acquired infection. One-fifth of patients had sepsis and there was no evidence of heterogeneity

in treatment effects across subgroups, including the sepsis subjects. Therefore, no studies suggest the superiority of TPN over enteral alone in the first 24 hrs. In fact, there is a suggestion that enteral nutrition may in fact be superior to TPN vis-à-vis infectious complications and possibly requirement for intensive care and organ support.

Immune system function can be modified through alterations in the supply of certain nutrients, such as arginine, glutamine, or omega-3 fatty acids. Numerous studies have assessed whether use of these agents as nutritional supplements can affect the course of critical illness, but few specifically addressed their early use in sepsis. Four meta-analyses evaluated immune-enhancing nutrition and found no difference in mortality, neither in surgical nor medical patients (445–448). However, they analyzed all studies together, regardless of the immunocomponent used, which could have compromised their conclusions. Other individual studies analyzed diets with a mix of arginine, glutamine, antioxidants, and/or omega-3 with negative results (449, 450) including a small study in septic patients showing a nonsignificant increase in ICU mortality (451, 452).

#### **Arginine.**

Arginine availability is reduced in sepsis, which can lead to reduced nitric oxide synthesis, loss of microcirculatory regulation, and enhanced production of superoxide and peroxynitrite. However, arginine supplementation could lead to unwanted vasodilation and hypotension (452, 453). Human trials of L-arginine supplementation have generally been small and reported variable effects on mortality (454–457). The only study in septic patients showed improved survival, but had limitations in study design (455). Other studies suggested no benefit (449, 454, 455) or possible harm (455) in the subgroup of septic patients. Some authors found improvement in secondary outcomes in septic patients, such as reduced infectious complications (454, 455) and length of hospital stay (454), but the relevance of these findings in the face of potential harm is unclear.

#### **Glutamine.**

Glutamine levels are also reduced during critical illness. Exogenous supplementation can improve gut mucosal atrophy and permeability, possibly leading to reduced bacterial translocation. Other potential benefits are enhanced immune cell function, decreased pro-inflammatory cytokine production, and higher levels of glutathione and antioxidative capacity (452, 453). However, the clinical significance of these findings is not clearly established.

Although a previous meta-analysis showed mortality reduction (428), four other meta-analyses did not (458–462). Other small studies not included in those meta-analyses had similar results (463, 464). Three recent well-designed studies also failed to show a mortality benefit in the primary analyses (227, 465, 466), but again, none focused specifically on septic patients. Two small studies on septic patients showed no benefit in mortality rates (467, 468) but a significant reduction in infectious complications (467) and a faster recovery of organ dysfunction (468). Some previous individual studies and meta-analyses

showed positive secondary outcomes, such as reduction in infectious morbidity (461, 462, 465) and organ dysfunction (462). Beneficial effects were found mostly in trials using parenteral rather than enteral glutamine. However, recent and well-sized studies could not demonstrate a reduction of infectious complications (227) or organ dysfunction (465, 466), even with parenteral glutamine. An ongoing trial (REDOXS) of 1,200 patients will test both enteral and parenteral glutamine and antioxidant supplementation in critically ill, mechanically ventilated patients (469). Although no clear benefit could be demonstrated in clinical trials with supplemental glutamine, there is no sign of harm.

The omega-3 fatty acids eicosapentaenoic acid (EPA) and gamma-linolenic acid (GLA) are eicosanoid precursors. The prostaglandins, leukotrienes, and thromboxanes produced from EPA/GLA are less potent than their arachidonic acid-derived equivalents, reducing the pro-inflammatory impact on the immune response (452, 453). Three early studies were summarized in a meta-analysis that reported a significant mortality reduction, increased ventilator-free days, and reduced risk of new organ dysfunction (470). However, only one study was in septic patients (471), none was individually powered for mortality (472, 473), and all three used a diet with high omega-6 lipid content in the control group, which is not the usual standard of care in the critically ill. The authors who first reported reduced mortality in sepsis (471) conducted a follow-up multicenter study and again found improvement in nonmortality outcomes, though notably with no demonstrable effect on mortality (474). Other studies using enteral (475–477) or parenteral (478–480) fish oil failed to confirm these findings in general critical illness or acute lung injury. Thus, no large, reproducible findings suggest a clear benefit in the use of immunomodulating nutritional supplements in sepsis, though larger trials are ongoing.

## W. Setting Goals of Care

1. We recommend that goals of care and prognosis be discussed with patients and families (grade 1B).
2. We recommend that the goals of care be incorporated into treatment and end-of-life care planning, utilizing palliative care principles where appropriate (grade 1B).
3. We suggest that goals of care be addressed as early as feasible, but no later than within 72 hrs of ICU admission (grade 2C).

**Rationale.** The majority of ICU patients receive full support with aggressive, life-sustaining treatments. Many patients with multiple organ system failure or severe neurologic injuries will not survive or will have a poor quality of life. Decisions to provide less-aggressive life-sustaining treatments or to withdraw life-sustaining treatments in these patients may be in the patient's best interest and may be what patients and their families desire (481). Physicians have different end-of-life practices based on their region of practice, culture, and religion (482). Although the outcome of intensive care treatment in critically ill patients may be difficult to prognosticate accurately, establishing realistic treatment goals is important in promoting patient-centered care in the ICU (483). Models for structuring initiatives to enhance care

in the ICU highlight the importance of incorporating goals of care along with the prognosis into treatment plans (484). Additionally, discussing the prognosis for achieving the goals of care and level of certainty of prognosis has been identified as an important component of surrogate decision-making in the ICU (485, 486). However, variations exist in the use of advanced care planning and integration of palliative and end-of-life care in the ICU, which can lead to conflicts that may threaten overall quality of care (487, 488). The use of proactive family care conferences to identify advanced directives and treatment goals within 72 hrs of ICU admission promotes communication and understanding between the patient's family and the care team; improves family satisfaction; decreases stress, anxiety, and depression in surviving relatives; facilitates end-of-life decision making; and shortens length of stay for patients who die in the ICU (489–494). Clinical practice guidelines for support of the ICU patient and family promote: early and repeated care conferencing to reduce family stress and improve consistency in communication; open flexible visitation; family presence during clinical rounds and resuscitation; and attention to cultural and spiritual support (495). Additionally, the integration of advanced care planning and palliative care focused on pain management, symptom control, and family support has been shown to improve symptom management and patient comfort, and to improve family communication (484, 490, 496).

## PEDIATRIC CONSIDERATIONS IN SEVERE SEPSIS (TABLE 9)

While sepsis in children is a major cause of death in industrialized countries with state-of-the-art ICUs, the overall mortality from severe sepsis is much lower than that in adults, estimated at about 2% to 10% (497–499). The hospital mortality rate for severe sepsis is 2% in previously healthy children and 8% in chronically ill children in the United States (497). Definitions of sepsis, severe sepsis, septic shock, and multiple organ dysfunction/failure syndromes are similar to adult definitions but depend on age-specific heart rate, respiratory rate, and white blood cell count cutoff values (500, 501). This document provides recommendations only for term newborns and children in the industrialized resource-rich setting with full access to mechanical ventilation ICUs.

### A. Initial Resuscitation

1. We suggest starting with oxygen administered by face mask or, if needed and available, high-flow nasal cannula oxygen or nasopharyngeal continuous positive airway pressure (CPAP) for respiratory distress and hypoxemia. Peripheral intravenous access or intraosseous access can be used for fluid resuscitation and inotrope infusion when a central line is not available. If mechanical ventilation is required, then cardiovascular instability during intubation is less likely after appropriate cardiovascular resuscitation (grade 2C).

**Rationale.** Due to low functional residual capacity, young infants and neonates with severe sepsis may require early intubation; however, during intubation and mechanical ventilation,

**TABLE 9. Recommendations: Special Considerations in Pediatrics****A. Initial Resuscitation**

1. For respiratory distress and hypoxemia start with face mask oxygen or if needed and available, high flow nasal cannula oxygen or nasopharyngeal CPAP (NP CPAP). For improved circulation, peripheral intravenous access or intraosseous access can be used for fluid resuscitation and inotrope infusion when a central line is not available. If mechanical ventilation is required then cardiovascular instability during intubation is less likely after appropriate cardiovascular resuscitation (grade 2C).
2. Initial therapeutic end points of resuscitation of septic shock: capillary refill of  $\leq 2$  secs, normal blood pressure for age, normal pulses with no differential between peripheral and central pulses, warm extremities, urine output  $>1 \text{ mL}\cdot\text{kg}^{-1}\cdot\text{hr}^{-1}$ , and normal mental status.  $\text{Scvo}_2$  saturation  $\geq 70\%$  and cardiac index between 3.3 and  $6.0 \text{ L}/\text{min}/\text{m}^2$  should be targeted thereafter (grade 2C).
3. Follow American College of Critical Care Medicine-Pediatric Life Support (ACCM-PALS) guidelines for the management of septic shock (grade 1C).
4. Evaluate for and reverse pneumothorax, pericardial tamponade, or endocrine emergencies in patients with refractory shock (grade 1C).

**B. Antibiotics and Source Control**

1. Empiric antibiotics be administered within 1 hr of the identification of severe sepsis. Blood cultures should be obtained before administering antibiotics when possible but this should not delay administration of antibiotics. The empiric drug choice should be changed as epidemic and endemic ecologies dictate (eg H1N1, MRSA, chloroquine resistant malaria, penicillin-resistant pneumococci, recent ICU stay, neutropenia ) (grade 1D).
2. Clindamycin and anti-toxin therapies for toxic shock syndromes with refractory hypotension (grade 2D).
3. Early and aggressive source control (grade 1D).
4. *Clostridium difficile* colitis should be treated with enteral antibiotics if tolerated. Oral vancomycin is preferred for severe disease (grade 1A).

**C. Fluid Resuscitation**

1. In the industrialized world with access to inotropes and mechanical ventilation, initial resuscitation of hypovolemic shock begins with infusion of isotonic crystalloids or albumin with boluses of up to  $20 \text{ mL}/\text{kg}$  crystalloids (or albumin equivalent ) over 5–10 minutes, titrated to reversing hypotension, increasing urine output, and attaining normal capillary refill, peripheral pulses, and level of consciousness without inducing hepatomegaly or rales. If hepatomegaly or rales exist then inotropic support should be implemented, not fluid resuscitation. In non-hypotensive children with severe hemolytic anemia (severe malaria or sickle cell crises) blood transfusion is considered superior to crystalloid or albumin bolusing (grade 2C).

**D. Inotropes/Vasopressors/Vasodilators**

1. Begin peripheral inotropic support until central venous access can be attained in children who are not responsive to fluid resuscitation (grade 2C).
2. Patients with low cardiac output and elevated systemic vascular resistance states with normal blood pressure be given vasodilator therapies in addition to inotropes (grade 2C).

**E. Extracorporeal Membrane Oxygenation (ECMO)**

1. Consider ECMO for refractory pediatric septic shock and respiratory failure (grade 2C).

**F. Corticosteroids**

1. Timely hydrocortisone therapy in children with fluid refractory, catecholamine resistant shock and suspected or proven absolute (classic) adrenal insufficiency (grade 1A).

**G. Protein C and Activated Protein Concentrate**

*No recommendation as no longer available.*

**H. Blood Products and Plasma Therapies**

1. Similar hemoglobin targets in children as in adults. During resuscitation of low superior vena cava oxygen saturation shock ( $< 70\%$ ), hemoglobin levels of  $10 \text{ g}/\text{dL}$  are targeted. After stabilization and recovery from shock and hypoxemia then a lower target  $> 7.0 \text{ g}/\text{dL}$  can be considered reasonable (grade 1B).
2. Similar platelet transfusion targets in children as in adults (grade 2C).
3. Use plasma therapies in children to correct sepsis-induced thrombotic purpura disorders, including progressive disseminated intravascular coagulation, secondary thrombotic microangiopathy, and thrombotic thrombocytopenic purpura (grade 2C).

**I. Mechanical Ventilation.**

- 1 Lung-protective strategies during mechanical ventilation (grade 2C)

(Continued)

**TABLE 9. (Continued) Recommendations: Special Considerations in Pediatrics****J. Sedation/Analgesia/Drug Toxicities**

1. We recommend use of sedation with a sedation goal in critically ill mechanically ventilated patients with sepsis (grade 1D).
2. Monitor drug toxicity labs because drug metabolism is reduced during severe sepsis, putting children at greater risk of adverse drug-related events (grade 1C).

**K. Glycemic Control**

1. Control hyperglycemia using a similar target as in adults  $\leq 180$  mg/dL. Glucose infusion should accompany insulin therapy in newborns and children because some hyperglycemic children make no insulin whereas others are insulin resistant (grade 2C).

**L. Diuretics and Renal Replacement Therapy**

1. Use diuretics to reverse fluid overload when shock has resolved, and if unsuccessful then continuous venovenous hemofiltration (CVVH) or intermittent dialysis to prevent  $> 10\%$  total body weight fluid overload (grade 2C).

**M. Deep Vein Thrombosis (DVT) Prophylaxis**

No recommendation on the use of DVT prophylaxis in prepubertal children with severe sepsis.

**N. Stress Ulcer(SU) Prophylaxis**

No recommendation on the use of SU prophylaxis in prepubertal children with severe sepsis.

**O. Nutrition**

1. Enteral nutrition given to children who can be fed enterally, and parenteral feeding in those who cannot (grade 2C).

increased intrathoracic pressure can reduce venous return and lead to worsening shock if the patient is not volume loaded. In those who desaturate despite administration of face mask oxygen, high-flow nasal cannula oxygen or nasopharyngeal CPAP can be used to increase functional residual capacity and reduce the work of breathing, allowing for establishment of intravenous or intraosseous access for fluid resuscitation and peripheral inotrope delivery (502, 503). Drugs used for sedation have important side effects in these patients. For example, etomidate is associated with increased mortality in children with meningococcal sepsis because of adrenal suppression effect (504, 505). Because attainment of central access is more difficult in children than adults, reliance on peripheral or intraosseous access can be substituted until and unless central access is available.

2. We suggest that the initial therapeutic endpoints of resuscitation of septic shock be capillary refill of  $\leq 2$  s, normal blood pressure for age, normal pulses with no differential between peripheral and central pulses, warm extremities, urine output  $> 1$  mL/kg/hr, and normal mental status. Thereafter,  $ScvO_2$  saturation greater than or equal to 70% and cardiac index between 3.3 and 6.0 L/min/m<sup>2</sup> should be targeted (grade 2C).

**Rationale.** Adult guidelines recommend lactate clearance as well, but children commonly have normal lactate levels with septic shock. Because of the many modalities used to measure  $ScvO_2$  and cardiac index, the specific choice is left to the practitioner's discretion (506–512).

3. We recommend following the American College of Critical Care Medicine-Pediatric Advanced Life Support guidelines for the management of septic shock (grade 1C).

**Rationale.** The recommended guidelines are summarized in **Figure 2** (510–512).

4. We recommend evaluating for and reversing pneumothorax, pericardial tamponade, or endocrine emergencies in patients with refractory shock (grade 1C).

**Rationale.** Endocrine emergencies include hypoadrenalism and hypothyroidism. In select patients, intra-abdominal hypertension may also need to be considered (513–515).

**B. Antibiotics and Source Control**

1. We recommend that empiric antimicrobials be administered within 1 hr of the identification of severe sepsis. Blood cultures should be obtained before administering antibiotics when possible, but this should not delay initiation of antibiotics. The empiric drug choice should be changed as epidemic and endemic ecologies dictate (eg, H1N1, methicillin-resistant *S. aureus*, chloroquine-resistant malaria, penicillin-resistant pneumococci, recent ICU stay, neutropenia) (grade 1D).

**Rationale.** Vascular access and blood drawing is more difficult in newborns and children. Antimicrobials can be given intramuscularly or orally (if tolerated) until intravenous line access is available (516–519).

2. We suggest the use of clindamycin and antitoxin therapies for toxic shock syndromes with refractory hypotension (grade 2D).

**Rationale.** Children are more prone to toxic shock than adults because of their lack of circulating antibodies to toxins. Children with severe sepsis and erythroderma and suspected toxic shock should be treated with clindamycin to reduce toxin production. The role of IVIG in toxic shock syndrome



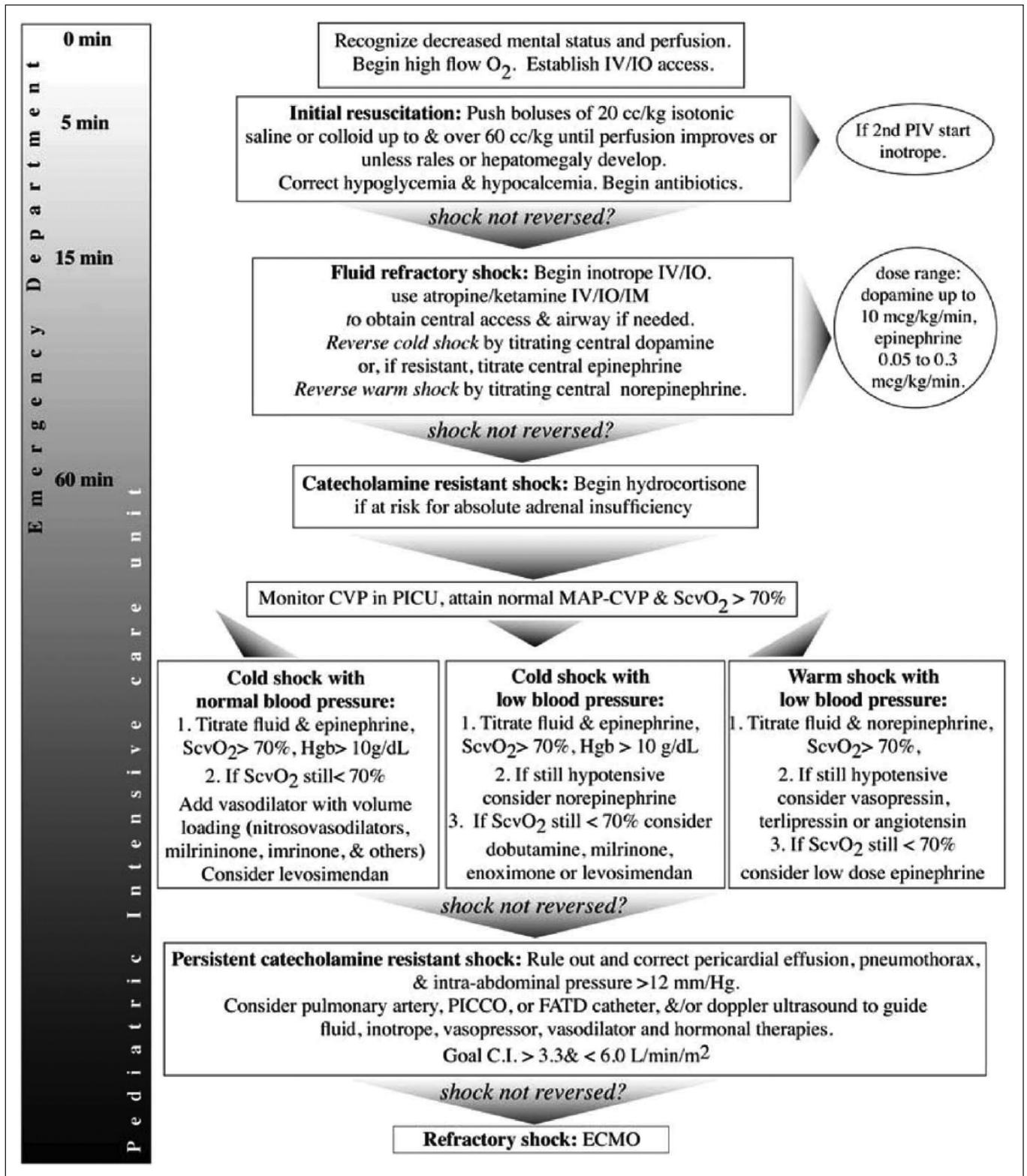

**Figure 2.** Algorithm for time sensitive, goal-directed stepwise management of hemodynamic support in infants and children. Reproduced from Brierley J, Carcillo J, Choong K, et al: Clinical practice parameters for hemodynamic support of pediatric and neonatal septic shock: 2007 update from the American College of Critical Care Medicine. *Crit Care Med* 2009; 37:666–688.

is unclear, but it may be considered in refractory toxic shock syndrome (520–527).

3. We recommend early and aggressive infection source control (grade 1D).

**Rationale.** Débridement and source control is paramount in severe sepsis and septic shock. Conditions requiring débridement or drainage include necrotizing pneumonia, necrotizing fasciitis, gangrenous myonecrosis, empyema, and abscesses. Perforated

viscus requires repair and peritoneal washout. Delay in use of an appropriate antibiotic, inadequate source control, and failure to remove infected devices are associated with increased mortality in a synergistic manner (528–538).

4. *C. difficile* colitis should be treated with enteral antibiotics if tolerated. Oral vancomycin is preferred for severe disease (grade 1A).

**Rationale.** In adults, metronidazole is a first choice; however, response to treatment with *C. difficile* can be best with enteral vancomycin. In very severe cases where diverting ileostomy or colectomy is performed, parenteral treatment should be considered until clinical improvement is ascertained (539–541).

### C. Fluid Resuscitation

1. In the industrialized world with access to inotropes and mechanical ventilation, we suggest that initial resuscitation of hypovolemic shock begin with infusion of isotonic crystalloids or albumin, with boluses of up to 20 mL/kg for crystalloids (or albumin equivalent) over 5 to 10 mins. These should be titrated to reversing hypotension, increasing urine output, and attaining normal capillary refill, peripheral pulses and level of consciousness without inducing hepatomegaly or rales. If hepatomegaly or rales develop, inotropic support should be implemented, not fluid resuscitation. In children with severe hemolytic anemia (severe malaria or sickle cell crises) who are not hypotensive, blood transfusion is considered superior to crystalloid or albumin bolusing (grade 2C).

**Rationale.** Three RCTs compared the use of colloid to crystalloid resuscitation in children with hypovolemic dengue shock with near 100% survival in all treatment arms (542–544). In the industrialized world, two before-and-after studies observed 10-fold reductions in mortality when children with purpura/meningococcal septic shock were treated with fluid boluses, inotropes, and mechanical ventilation in the community emergency department (545, 546). In one randomized trial, septic shock mortality was reduced (40% to 12%) when increased fluid boluses, blood, and inotropes were given to attain a ScvO<sub>2</sub> monitoring goal of greater than 70% (511). A quality improvement study achieved a reduction in severe sepsis mortality (from 4.0% to 2.4%) with the delivery of fluid boluses and antibiotics in the first hour in a pediatric emergency department to reverse clinical signs of shock (547).

Children normally have a lower blood pressure than adults, and a fall in blood pressure can be prevented by vasoconstriction and increasing heart rate. Therefore, blood pressure alone is not a reliable endpoint for assessing the adequacy of resuscitation. However, once hypotension occurs, cardiovascular collapse may soon follow. Thus, fluid resuscitation is recommended for both normotensive and hypotensive children in hypovolemic shock (542–554). Because hepatomegaly and/or rales occur in children who are fluid overloaded, these findings can be helpful signs of hypervolemia. In the absence of these signs, large fluid deficits can exist, and initial volume

resuscitation can require 40 to 60 mL/kg or more; however, if these signs are present, then fluid administration should be ceased and diuretics should be given. Inotrope infusions and mechanical ventilation are commonly required for children with fluid-refractory shock.

### D. Inotropes/Vasopressors/Vasodilators

1. We suggest beginning peripheral inotropic support until central venous access can be attained in children who are not responsive to fluid resuscitation (grade 2C).

**Rationale.** Cohort studies show that delay in the use of inotropic therapies is associated with major increases in mortality risk (553, 554). This delay is often related to difficulty in attaining central access. In the initial resuscitation phase, inotrope/vasopressor therapy may be required to sustain perfusion pressure, even when hypovolemia has not yet been resolved. Children with severe sepsis can present with low cardiac output and high systemic vascular resistance, high cardiac output and low systemic vascular resistance, or low cardiac output and low systemic vascular resistance shock (555). A child may move from one hemodynamic state to another. Vasopressor or inotrope therapy should be used according to the hemodynamic state (555). Dopamine-refractory shock may reverse with epinephrine or norepinephrine infusion. In the case of extremely low systemic vascular resistance despite the use of norepinephrine, the use of vasopressin and terlipressin has been described in a number of case reports, yet evidence to support this in pediatric sepsis, as well as safety data, are still lacking. Indeed, two RCTs showed no benefit in outcome with use of vasopressin or terlipressin in children (556–559). Interestingly, while vasopressin levels are reduced in adults with septic shock, such levels seem to vary extensively in children. When vasopressors are used for refractory hypotension, the addition of inotropes is commonly needed to maintain adequate cardiac output (510, 511, 555).

2. We suggest that patients with low cardiac output and elevated systemic vascular resistance states with normal blood pressure be given vasodilator therapies in addition to inotropes (grade 2C).

**Rationale.** The choice of vasoactive agent is initially determined by the clinical examination; however, for the child with invasive monitoring in place and demonstration of a persistent low cardiac output state with high systemic vascular resistance and normal blood pressure despite fluid resuscitation and inotropic support, vasodilator therapy can reverse shock. Type III phosphodiesterase inhibitors (amrinone, milrinone, enoximone) and the calcium sensitizer levosimendan can be helpful because they overcome receptor desensitization. Other important vasodilators include nitrovasodilators, prostacyclin, and fenoldopam. In two RCTs, pentoxifylline reduced mortality from severe sepsis in newborns (510, 560–569).

## E. Extracorporeal Membrane Oxygenation

1. We suggest ECMO in children with refractory septic shock or with refractory respiratory failure associated with sepsis (grade 2C).

**Rationale.** ECMO may be used to support children and neonates with septic shock or sepsis-associated respiratory failure (570, 571). The survival of septic patients supported with ECMO is 73% for newborns and 39% for older children, and is highest in those receiving venovenous ECMO (572). Forty-one percent of children with a diagnosis of sepsis requiring ECMO for respiratory failure survive to hospital discharge (573). Venoarterial ECMO is useful in children with refractory septic shock (574), with one center reporting 74% survival to hospital discharge using central cannulation via sternotomy (575). ECMO has been used successfully in critically ill H1N1 pediatric patients with refractory respiratory failure (576, 577).

## F. Corticosteroids

1. We suggest timely hydrocortisone therapy in children with fluid-refractory, catecholamine-resistant shock and suspected or proven absolute (classic) adrenal insufficiency (grade 1A).

**Rationale.** Approximately 25% of children with septic shock have absolute adrenal insufficiency. Patients at risk for absolute adrenal insufficiency include children with severe septic shock and purpura, those who have previously received steroid therapies for chronic illness, and children with pituitary or adrenal abnormalities. Initial treatment is hydrocortisone infusion given at stress doses (50 mg/m<sup>2</sup>/24 hr); however, infusions up to 50 mg/kg/d may be required to reverse shock in the short-term. Death from absolute adrenal insufficiency and septic shock occurs within 8 hrs of presentation. Obtaining a serum cortisol level at the time empiric hydrocortisone is administered may be helpful (578–583).

## G. Protein C and Activated Protein Concentrate

See section, History of Recommendations Regarding Use of Recombinant Activated Protein C.

## H. Blood Products and Plasma Therapies

1. We suggest similar hemoglobin targets in children as in adults. During resuscitation of low superior vena cava oxygen saturation shock (< 70%), hemoglobin levels of 10 g/dL are targeted. After stabilization and recovery from shock and hypoxemia, then a lower target > 7.0 g/dL can be considered reasonable (grade 1B).

**Rationale.** The optimal hemoglobin for a critically ill child with severe sepsis is not known. A recent multicenter trial reported no difference in mortality in hemodynamically stable critically ill children managed with a transfusion threshold of 7 g/dL compared with those managed with a transfusion threshold of 9.5 g/dL; however, the severe sepsis subgroup had an increase

in nosocomial sepsis and lacked clear evidence of equivalence in outcomes with the restrictive strategy (584, 585). Blood transfusion is recommended by the World Health Organization for severe anemia, hemoglobin value < 5 g/dL, and acidosis. An RCT of early goal-directed therapy for pediatric septic shock using the threshold hemoglobin of 10 g/dL for patients with a Svco<sub>2</sub> saturation less than 70% in the first 72 hrs of pediatric ICU admission showed improved survival in the multimodal intervention arm (511).

2. We suggest similar platelet transfusion targets in children as in adults (grade 2C).
3. We suggest the use of plasma therapies in children to correct sepsis-induced thrombotic purpura disorders, including progressive disseminated intravascular coagulation, secondary thrombotic microangiopathy, and thrombotic thrombocytopenic purpura (grade 2C).

**Rationale.** We give plasma to reverse thrombotic microangiopathies in children with thrombocytopenia-associated multiple organ failure and progressive purpura because fresh frozen plasma contains protein C, antithrombin III, and other anticoagulant proteins. Rapid resuscitation of shock reverses most disseminated intravascular coagulation; however, purpura progresses in some children in part due to critical consumption of antithrombotic proteins (eg, protein C, antithrombin III, ADAMTS 13). Plasma is infused with the goal of correcting prolonged prothrombin/partial thromboplastin times and halting purpura. Large volumes of plasma require concomitant use of diuretics, continuous renal replacement therapy, or plasma exchange to prevent greater than 10% fluid overload (586–611).

## I. Mechanical Ventilation

1. We suggest providing lung-protective strategies during mechanical ventilation (grade 2C).

**Rationale.** Some patients with ARDS will require increased PEEP to attain functional residual capacity and maintain oxygenation, and peak pressures above 30 to 35 cm H<sub>2</sub>O to attain effective tidal volumes of 6 to 8 mL/kg with adequate CO<sub>2</sub> removal. In these patients, physicians generally transition from conventional pressure control ventilation to pressure release ventilation (airway pressure release ventilation) or to high-frequency oscillatory ventilation. These modes maintain oxygenation with higher mean airway pressures using an “open” lung ventilation strategy. To be effective, these modes can require a mean airway pressure 5 cm H<sub>2</sub>O higher than that used with conventional ventilation. This can reduce venous return leading to greater need for fluid resuscitation and vasopressor requirements (612–616).

## J. Sedation/Analgesia/Drug Toxicities

1. We recommend use of sedation with a sedation goal in critically ill mechanically ventilated patients with sepsis (grade 1D).



**Rationale.** Although there are no data supporting any particular drugs or regimens, propofol should not be used for long-term sedation in children younger than 3 years because of the reported association with fatal metabolic acidosis. The use of etomidate and/or dexmedetomidine during septic shock should be discouraged, or at least considered carefully, because these drugs inhibit the adrenal axis and the sympathetic nervous system, respectively, both of which are needed for hemodynamic stability (617–620).

2. We recommend monitoring drug toxicity labs because drug metabolism is reduced during severe sepsis, putting children at greater risk of adverse drug-related events (grade 1C).

**Rationale.** Children with severe sepsis have reduced drug metabolism (621).

### K. Glycemic Control

1. We suggest controlling hyperglycemia using a similar target as in adults ( $\leq 180$  mg/dL). Glucose infusion should accompany insulin therapy in newborns and children (grade 2C).

**Rationale.** In general, infants are at risk for developing hypoglycemia when they depend on intravenous fluids. This means that a glucose intake of 4 to 6 mg/kg/min or maintenance fluid intake with dextrose 10% normal saline containing solution is advised (6–8 mg/kg/min in newborns). Associations have been reported between hyperglycemia and an increased risk of death and longer length of stay. A retrospective pediatric ICU study reported associations of hyperglycemia, hypoglycemia, and glucose variability with increased length of stay and mortality rates. An RCT of strict glycemic control compared to moderate control using insulin in a pediatric ICU population found a reduction in mortality with an increase in hypoglycemia. Insulin therapy should only be conducted with frequent glucose monitoring in view of the risks for hypoglycemia which can be greater in newborns and children due to a) relative lack of glycogen stores and muscle mass for gluconeogenesis, and b) the heterogeneity of the population with some excreting no endogenous insulin and others demonstrating high insulin levels and insulin resistance (622–628).

### L. Diuretics and Renal Replacement Therapy

1. We suggest the use of diuretics to reverse fluid overload when shock has resolved and if unsuccessful, then continuous venovenous hemofiltration or intermittent dialysis to prevent greater than 10% total body weight fluid overload (grade 2C).

**Rationale.** A retrospective study of children with meningococemia showed an associated mortality risk when children received too little or too much fluid resuscitation (549, 553). A retrospective study of 113 critically ill children with multiple organ dysfunction syndrome reported that patients with less

fluid overload before continuous venovenous hemofiltration had better survival (629–631),

### M. DVT Prophylaxis

1. We make no graded recommendations on the use of DVT prophylaxis in prepubertal children with severe sepsis.

**Rationale.** Most DVTs in young children are associated with central venous catheters. Heparin-bonded catheters may decrease the risk of catheter-associated DVT. No data exist on the efficacy of UFH or LMWH prophylaxis to prevent catheter-related DVT in children in the ICU (632, 633).

### N. Stress Ulcer Prophylaxis

1. We make no graded recommendations on stress ulcer prophylaxis.

**Rationale.** Studies have shown that clinically important GI bleeding in children occurs at rates similar to those of adults. Stress ulcer prophylaxis is commonly used in children who are mechanically ventilated, usually with H<sub>2</sub> blockers or proton pump inhibitors, although its effect is not known (634, 635).

### O. Nutrition

1. Enteral nutrition should be used in children who can tolerate it, parenteral feeding in those who cannot (grade 2C).

**Rationale.** Dextrose 10% (always with sodium-containing solution in children) at maintenance rate provides the glucose delivery requirements for newborns and children (636). Patients with sepsis have increased glucose delivery needs which can be met by this regimen. Specific measurement of caloric requirements are thought to be best attained using a metabolic cart as they are generally less in the critically ill child than in the healthy child.

## SUMMARY AND FUTURE DIRECTIONS

Although this document is static, the optimum treatment of severe sepsis and septic shock is a dynamic and evolving process. Additional evidence that has appeared since the publication of the 2008 guidelines allows more certainty with which we make severe sepsis recommendations; however, further programmatic clinical research in sepsis is essential to optimize these evidence-based medicine recommendations.

New interventions will be proven and established interventions may need modification. This publication represents an ongoing process. The Surviving Sepsis Campaign and the consensus committee members are committed to updating the guidelines regularly as new interventions are tested and results published.

## ACKNOWLEDGMENT

The revision process was funded through a grant from the Gordon and Betty Irene Moore Foundation. We would also like to acknowledge the dedication and untold hours of

donated time of committee members over the last 2 years; the sponsoring organizations that worked with us toward the reality of a consensus document across so many disciplines, specialties, and continents; and those that contribute in so many ways to create the new science to move us forward in treating this potentially devastating disease: the funders of research, the investigators, the subjects, and those associated with the evidence publishing bodies. Finally, we thank Deborah McBride for the incredible editorial support provided persistently over months that brought the manuscript to life and finalization.

## REFERENCES

1. Angus DC, Linde-Zwirble WT, Lidicker J, et al: Epidemiology of severe sepsis in the United States: Analysis of incidence, outcome, and associated costs of care. *Crit Care Med* 2001; 29:1303–1310
2. Dellinger RP: Cardiovascular management of septic shock. *Crit Care Med* 2003; 31:946–955
3. Martin GS, Mannino DM, Eaton S, et al: The epidemiology of sepsis in the United States from 1979 through 2000. *N Engl J Med* 2003; 348:1546–1554
4. Linde-Zwirble WT, Angus DC: Severe sepsis epidemiology: Sampling, selection, and society. *Crit Care* 2004; 8:222–226
5. Dombrovskiy VY, Martin AA, Sunderram J, et al: Rapid increase in hospitalization and mortality rates for severe sepsis in the United States: A trend analysis from 1993 to 2003. *Crit Care Med* 2007; 35:1414–1415
6. Levy MM, Fink MP, Marshall JC, et al; SCCM/ESICM/ACCP/ATS/SIS: 2001 SCCM/ESICM/ACCP/ATS/SIS International Sepsis Definitions Conference. *Crit Care Med* 2003; 31:1250–1256
7. Dellinger RP, Levy MM, Carlet JM, et al: Surviving Sepsis Campaign: International guidelines for management of severe sepsis and septic shock: 2008. *Crit Care Med* 2008; [pub corrections appears in 2008; 36:1394–1396] 36:296–327
8. Dellinger RP, Carlet JM, Masur H, et al: Surviving Sepsis Campaign guidelines for management of severe sepsis and septic shock. *Crit Care Med* 2004; 32:858–873
9. Guyatt GH, Oxman AD, Vist GE, et al; GRADE Working Group: GRADE: An emerging consensus on rating quality of evidence and strength of recommendations. *BMJ* 2008; 336:924–926
10. Guyatt GH, Oxman AD, Kunz R, et al; GRADE Working Group: What is “quality of evidence” and why is it important to clinicians? *BMJ* 2008; 336:995–998
11. Guyatt GH, Oxman AD, Kunz R, et al; GRADE Working Group: Going from evidence to recommendations. *BMJ* 2008; 336:1049–1051
12. Brozek J, Oxman AD, Schünemann HJ: GRADEpro (Computer Program) Version 3.2 for Windows. Available at <http://www.cc-ims.net/rvman/gradepro>, 2012
13. Rivers E, Nguyen B, Havstad S, et al; Early Goal-Directed Therapy Collaborative Group: Early goal-directed therapy in the treatment of severe sepsis and septic shock. *N Engl J Med* 2001; 345:1368–1377
14. Early Goal-Directed Therapy Collaborative Group of Zhejiang Province: The effect of early goal-directed therapy on treatment of critical patients with severe sepsis/septic shock: A multi-center, prospective, randomized, controlled study [in Chinese]. *Zhongguo Wei Zhong Bing Ji Jiu Yi Xue* 2010; 6:331–334
15. Levy MM, Dellinger RP, Townsend SR, et al; Surviving Sepsis Campaign: The Surviving Sepsis Campaign: Results of an international guideline-based performance improvement program targeting severe sepsis. *Crit Care Med* 2010; 38:367–374
16. Bendjelid K, Romand JA: Fluid responsiveness in mechanically ventilated patients: A review of indices used in intensive care. *Intensive Care Med* 2003; 29:352–360
17. Malbrain ML, Deeren D, De Potter TJ: Intra-abdominal hypertension in the critically ill: It is time to pay attention. *Curr Opin Crit Care* 2005; 11:156–171
18. Varpula M, Tallgren M, Saukkonen K, et al: Hemodynamic variables related to outcome in septic shock. *Intensive Care Med* 2005; 31:1066–1071
19. Kortgen A, Niederprüm P, Bauer M: Implementation of an evidence-based “standard operating procedure” and outcome in septic shock. *Crit Care Med* 2006; 34:943–949
20. Sebat F, Johnson D, Musthafa AA, et al: A multidisciplinary community hospital program for early and rapid resuscitation of shock in non-trauma patients. *Chest* 2005; 127:1729–1743
21. Shapiro NI, Howell MD, Talmor D, et al: Implementation and outcomes of the Multiple Urgent Sepsis Therapies (MUST) protocol. *Crit Care Med* 2006; 34:1025–1032
22. Micek ST, Roubinian N, Heuring T, et al: Before-after study of a standardized hospital order set for the management of septic shock. *Crit Care Med* 2006; 34:2707–2713
23. Nguyen HB, Corbett SW, Steele R, et al: Implementation of a bundle of quality indicators for the early management of severe sepsis and septic shock is associated with decreased mortality. *Crit Care Med* 2007; 35:1105–1112
24. Shorr AF, Micek ST, Jackson WL Jr, et al: Economic implications of an evidence-based sepsis protocol: Can we improve outcomes and lower costs? *Crit Care Med* 2007; 35:1257–1262
25. Reinhart K, Kuhn HJ, Hartog C, et al: Continuous central venous and pulmonary artery oxygen saturation monitoring in the critically ill. *Intensive Care Med* 2004; 30:1572–1578
26. Trzeciak S, Dellinger RP, Abate NL, et al: Translating research to clinical practice: A 1-year experience with implementing early goal-directed therapy for septic shock in the emergency department. *Chest* 2006; 129:225–232
27. Magder S: Central venous pressure: A useful but not so simple measurement. *Crit Care Med* 2006; 34:2224–2227
28. Bendjelid K: Right atrial pressure: Determinant or result of change in venous return? *Chest* 2005; 128:3639–3640
29. Vincent JL, Weil MH: Fluid challenge revisited. *Crit Care Med* 2006; 34:1333–1337
30. Trzeciak S, Dellinger RP, Parrillo JE, et al: Early microcirculatory perfusion derangements in patients with severe sepsis and septic shock: Relationship to hemodynamics, oxygen transport, and survival. *Ann Emerg Med* 2007; 49:88–98
31. De Backer D, Creteur J, Dubois MJ, et al: The effects of dobutamine on microcirculatory alterations in patients with septic shock are independent of its systemic effects. *Crit Care Med* 2006; 34:403–408
32. Buwalda M, Ince C: Opening the microcirculation: Can vasodilators be useful in sepsis? *Intensive Care Med* 2002; 28:1208–1217
33. Boldt J: Clinical review: Hemodynamic monitoring in the intensive care unit. *Crit Care* 2002; 6:52–59
34. Pinsky MR, Payen D: Functional hemodynamic monitoring. *Crit Care* 2005; 9:566–572
35. Jones AE, Shapiro NI, Trzeciak S, et al; Emergency Medicine Shock Research Network (EMShockNet) Investigators: Lactate clearance vs central venous oxygen saturation as goals of early sepsis therapy: A randomized clinical trial. *JAMA* 2010; 303:739–746
36. Jansen TC, van Bommel J, Schoonderbeek FJ, et al; LACTATE study group: Early lactate-guided therapy in intensive care unit patients: A multicenter, open-label, randomized controlled trial. *Am J Respir Crit Care Med* 2010; 182:752–761
37. Cinel I, Dellinger RP: Current treatment of severe sepsis. *Curr Infect Dis Rep* 2006; 8:358–365
38. Moore LJ, Jones SL, Kreiner LA, et al: Validation of a screening tool for the early identification of sepsis. *J Trauma* 2009; 66:1539–46; discussion 1546
39. Subbe CP, Kruger M, Rutherford P, et al: Validation of a modified Early Warning Score in medical admissions. *QJM* 2001; 94:521–526
40. Evaluation for Severe Sepsis Screening Tool, Institute for Healthcare Improvement (IHI). <http://www.ihl.org/IHI/Topics/CriticalCare/Sepsis/Tools/EvaluationforSevereSepsisScreeningTool.htm>
41. Evaluation for severe sepsis screening tool. <http://www.survivingsepsis.org/files/Tools/evaluationforseveresepsisscreeningtool.pdf>

42. Rivers EP, Ahrens T: Improving outcomes for severe sepsis and septic shock: Tools for early identification of at-risk patients and treatment protocol implementation. *Crit Care Clin* 2008; 24(3 Suppl):S1–47
43. Gao F, Melody T, Daniels DF, et al: The impact of compliance with 6-hour and 24-hour sepsis bundles on hospital mortality in patients with severe sepsis: A prospective observational study. *Crit Care* 2005; 9:R764–R770
44. Schorr C: Performance improvement in the management of sepsis. *Crit Care Clin* 2009; 25:857–867
45. Girardis M, Rinaldi L, Donno L, et al; Sopravvivere alla Sepsis Group of the Modena-University Hospital: Effects on management and outcome of severe sepsis and septic shock patients admitted to the intensive care unit after implementation of a sepsis program: A pilot study. *Crit Care* 2009; 13:R143
46. Pestaña D, Espinosa E, Sangüesa-Molina JR, et al; REASEP Sepsis Study Group: Compliance with a sepsis bundle and its effect on intensive care unit mortality in surgical septic shock patients. *J Trauma* 2010; 69:1282–1287
47. Berenholtz SM, Pronovost PJ, Ngo K, et al; Core Sepsis Measurement Team: Developing quality measures for sepsis care in the ICU. *Jt Comm J Qual Patient Saf* 2007; 33:559–568
48. Black MD, Schorr C, Levy MM: Knowledge translation and the multifaceted intervention in the intensive care unit. *Crit Care Med* 2012; 40:1324–1328
49. Suarez D, Ferrer R, Artigas A, et al; Edusepsis Study Group: Cost-effectiveness of the Surviving Sepsis Campaign protocol for severe sepsis: A prospective nation-wide study in Spain. *Intensive Care Med* 2011; 37:444–452
50. Levy MM, Pronovost PJ, Dellinger RP, et al: Sepsis change bundles: Converting guidelines into meaningful change in behavior and clinical outcome. *Crit Care Med* 2004; 32(11 Suppl):S595–S597
51. Weinstein MP, Reller LB, Murphy JR, et al: The clinical significance of positive blood cultures: A comprehensive analysis of 500 episodes of bacteremia and fungemia in adults. I. Laboratory and epidemiologic observations. *Rev Infect Dis* 1983; 5:35–53
52. Blot F, Schmidt E, Nitenberg G, et al: Earlier positivity of central-venous- versus peripheral-blood cultures is highly predictive of catheter-related sepsis. *J Clin Microbiol* 1998; 36:105–109
53. Mermel LA, Maki DG: Detection of bacteremia in adults: Consequences of culturing an inadequate volume of blood. *Ann Intern Med* 1993; 119:270–272
54. Guidelines for the management of adults with hospital-acquired, ventilator-associated, and healthcare-associated pneumonia. *Am J Respir Crit Care Med* 2005; 171:388–416
55. Muscedere J, Dodek P, Keenan S, et al; VAP Guidelines Committee and the Canadian Critical Care Trials Group: Comprehensive evidence-based clinical practice guidelines for ventilator-associated pneumonia: Diagnosis and treatment. *J Crit Care* 2008; 23:138–147
56. Giamarellos-Bourboulis EJ, Giannopoulou P, Grecka P, et al: Should procalcitonin be introduced in the diagnostic criteria for the systemic inflammatory response syndrome and sepsis? *J Crit Care* 2004; 19:152–157
57. Uzzan B, Cohen R, Nicolas P, et al: Procalcitonin as a diagnostic test for sepsis in critically ill adults and after surgery or trauma: A systematic review and meta-analysis. *Crit Care Med* 2006; 34:1996–2003
58. Tang BM, Eslick GD, Craig JC, et al: Accuracy of procalcitonin for sepsis diagnosis in critically ill patients: Systematic review and meta-analysis. *Lancet Infect Dis* 2007; 7:210–217
59. Tenover FC: Rapid detection and identification of bacterial pathogens using novel molecular technologies: Infection control and beyond. *Clin Infect Dis* 2007; 44:418–423
60. Klouche M, Schröder U: Rapid methods for diagnosis of bloodstream infections. *Clin Chem Lab Med* 2008; 46:888–908
61. Tissari P, Zumla A, Tarkka E, et al: Accurate and rapid identification of bacterial species from positive blood cultures with a DNA-based microarray platform: An observational study. *Lancet* 2010; 375:224–230
62. Alam FF, Mustafa AS, Khan ZU: Comparative evaluation of (1, 3)-beta-D-glucan, mannan and anti-mannan antibodies, and *Candida* species-specific snPCR in patients with candidemia. *BMC Infect Dis* 2007; 7:103
63. Oliveri S, Trovato L, Betta P, et al: Experience with the Platelia *Candida* ELISA for the diagnosis of invasive candidosis in neonatal patients. *Clin Microbiol Infect* 2008; 14:391–393
64. Sendid B, Poirot JL, Tabouret M, et al: Combined detection of mannanemia and antimannan antibodies as a strategy for the diagnosis of systemic infection caused by pathogenic *Candida* species. *J Med Microbiol* 2002; 51:433–442
65. Sendid B, Jouault T, Coudriau R, et al: Increased sensitivity of mannanemia detection tests by joint detection of alpha- and beta-linked oligomannosides during experimental and human systemic candidiasis. *J Clin Microbiol* 2004; 42:164–171
66. Sendid B, Dotan N, Nseir S, et al: Antibodies against glucan, chitin, and *Saccharomyces cerevisiae* mannan as new biomarkers of *Candida albicans* infection that complement tests based on *C. albicans* mannan. *Clin Vaccine Immunol* 2008; 15:1868–1877
67. Yera H, Sendid B, Francois N, et al: Contribution of serological tests and blood culture to the early diagnosis of systemic candidiasis. *Eur J Clin Microbiol Infect Dis* 2001; 20:864–870
68. Kumar A, Roberts D, Wood KE, et al: Duration of hypotension before initiation of effective antimicrobial therapy is the critical determinant of survival in human septic shock. *Crit Care Med* 2006; 34:1589–1596
69. Morrell M, Fraser VJ, Kollef MH: Delaying the empiric treatment of candida bloodstream infection until positive blood culture results are obtained: A potential risk factor for hospital mortality. *Antimicrob Agents Chemother* 2005; 49:3640–3645
70. Ferrer R, Artigas A, Suarez D, et al; Edusepsis Study Group: Effectiveness of treatments for severe sepsis: A prospective, multicenter, observational study. *Am J Respir Crit Care Med* 2009; 180:861–866
71. Barie PS, Hydo LJ, Shou J, et al: Influence of antibiotic therapy on mortality of critical surgical illness caused or complicated by infection. *Surg Infect (Larchmt)* 2005; 6:41–54
72. Castellanos-Ortega A, Suberviola B, García-Astudillo LA, et al: Impact of the Surviving Sepsis Campaign protocols on hospital length of stay and mortality in septic shock patients: Results of a three-year follow-up quasi-experimental study. *Crit Care Med* 2010; 38:1036–1043
73. Puskarich MA, Trzeciak S, Shapiro NI, et al; Emergency Medicine Shock Research Network (EMSHOCKNET): Association between timing of antibiotic administration and mortality from septic shock in patients treated with a quantitative resuscitation protocol. *Crit Care Med* 2011; 39:2066–2071
74. El Solh AA, Akinnusi ME, Alsawalha LN, et al: Outcome of septic shock in older adults after implementation of the sepsis “bundle”. *J Am Geriatr Soc* 2008; 56:272–278
75. Gurnani PK, Patel GP, Crank CW, et al: Impact of the implementation of a sepsis protocol for the management of fluid-refractory septic shock: A single-center, before-and-after study. *Clin Ther* 2010; 32:1285–1293
76. Larsen GY, Mecham N, Greenberg R: An emergency department septic shock protocol and care guideline for children initiated at triage. *Pediatrics* 2011; 127:e1585–e1592
77. Barochia AV, Cui X, Vitberg D, et al: Bundled care for septic shock: An analysis of clinical trials. *Crit Care Med* 2010; 38:668–678
78. Pappas PG, Kauffman CA, Andes D, et al; Infectious Diseases Society of America: Clinical practice guidelines for the management of candidiasis: 2009 update by the Infectious Diseases Society of America. *Clin Infect Dis* 2009; 48:503–535
79. Leibovici L, Shraga I, Drucker M, et al: The benefit of appropriate empirical antibiotic treatment in patients with bloodstream infection. *J Intern Med* 1998; 244:379–386
80. Ibrahim EH, Sherman G, Ward S, et al: The influence of inadequate antimicrobial treatment of bloodstream infections on patient outcomes in the ICU setting. *Chest* 2000; 118:146–155
81. Ali MZ, Goetz MB: A meta-analysis of the relative efficacy and toxicity of single daily dosing versus multiple daily dosing of aminoglycosides. *Clin Infect Dis* 1997; 24:796–809
82. Amsden GW, Ballow CH, Bertino JS: Pharmacokinetics and pharmacodynamics of anti-infective agents. In: *Principles and Practice of*



- Infectious Diseases*. Seventh edition. Mandell GL, Bennett JE, Dolin R (Eds). Philadelphia, Churchill Livingstone, 2010, pp 297–307
83. Heyland DK, Johnson AP, Reynolds SC, et al: Procalcitonin for reduced antibiotic exposure in the critical care setting: A systematic review and an economic evaluation. *Crit Care Med* 2011; 39:1792–1799
  84. Jensen JU, Hein L, Lundgren B, et al; Procalcitonin And Survival Study (PASS) Group: Procalcitonin-guided interventions against infections to increase early appropriate antibiotics and improve survival in the intensive care unit: A randomized trial. *Crit Care Med* 2011; 39:2048–2058
  85. Brunkhorst FM, Oppert M, Marx G, et al; German Study Group Competence Network Sepsis (SepNet): Effect of empirical treatment with moxifloxacin and meropenem vs meropenem on sepsis-related organ dysfunction in patients with severe sepsis: A randomized trial. *JAMA* 2012; 307:2390–2399
  86. Kumar A, Safdar N, Kethireddy S, et al: A survival benefit of combination antibiotic therapy for serious infections associated with sepsis and septic shock is contingent only on the risk of death: A meta-analytic/meta-regression study. *Crit Care Med* 2010; 38:1651–1664
  87. Kumar A, Zarychanski R, Light B, et al; Cooperative Antimicrobial Therapy of Septic Shock (CATSS) Database Research Group: Early combination antibiotic therapy yields improved survival compared with monotherapy in septic shock: A propensity-matched analysis. *Crit Care Med* 2010; 38:1773–1785
  88. Micek ST, Welch EC, Khan J, et al: Empiric combination antibiotic therapy is associated with improved outcome against sepsis due to Gram-negative bacteria: A retrospective analysis. *Antimicrob Agents Chemother* 2010; 54:1742–1748
  89. Al-Hasan MN, Wilson JW, Lahr BD, et al: Beta-lactam and fluoroquinolone combination antibiotic therapy for bacteremia caused by gram-negative bacilli. *Antimicrob Agents Chemother* 2009; 53:1386–1394
  90. Klastersky J: Management of fever in neutropenic patients with different risks of complications. *Clin Infect Dis* 2004; 39 Suppl 1:S32–S37
  91. Martin-Loeches I, Lisboa T, Rodriguez A, et al: Combination antibiotic therapy with macrolides improves survival in intubated patients with community-acquired pneumonia. *Intensive Care Med* 2010; 36:612–620
  92. Rodriguez A, Mendia A, Sirvent JM, et al; CAPUCI Study Group: Combination antibiotic therapy improves survival in patients with community-acquired pneumonia and shock. *Crit Care Med* 2007; 35:1493–1498
  93. Baddour LM, Yu VL, Klugman KP, et al; International Pneumococcal Study Group: Combination antibiotic therapy lowers mortality among severely ill patients with pneumococcal bacteremia. *Am J Respir Crit Care Med* 2004; 170:440–444
  94. Safdar N, Handelsman J, Maki DG: Does combination antimicrobial therapy reduce mortality in Gram-negative bacteraemia? A meta-analysis. *Lancet Infect Dis* 2004; 4:519–527
  95. Paul M, Silbiger I, Grozinsky S, et al: Beta lactam antibiotic monotherapy versus beta lactam-aminoglycoside antibiotic combination therapy for sepsis. *Cochrane Database Syst Rev* 2006; 1: CD003344
  96. Garnacho-Montero J, Sa-Borges M, Sole-Violan J, et al: Optimal management therapy for *Pseudomonas aeruginosa* ventilator-associated pneumonia: An observational, multicenter study comparing monotherapy with combination antibiotic therapy. *Crit Care Med* 2007; 35:1888–1895
  97. Jain S, Kamimoto L, Bramley AM, et al; 2009 Pandemic Influenza A (H1N1) Virus Hospitalizations Investigation Team: Hospitalized patients with 2009 H1N1 influenza in the United States, April–June 2009. *N Engl J Med* 2009; 361:1935–1944
  98. Writing Committee of the WHO Consultation on Clinical Aspects of Pandemic (H1N1) 2009 Influenza; Bautista E, Chotpitayasunondh T, Gao Z, et al: Clinical aspects of pandemic 2009 influenza A (H1N1) virus infection. *N Engl J Med* 2010; 362:1708–1719
  99. Smith JR, Ariano RE, Toovey S: The use of antiviral agents for the management of severe influenza. *Crit Care Med* 2010; 38(4 Suppl):e43–e51
  100. Fiore AE, Fry A, Shay D, et al; Centers for Disease Control and Prevention (CDC): Antiviral agents for the treatment and chemoprophylaxis of influenza—recommendations of the Advisory Committee on Immunization Practices (ACIP). *MMWR Recomm Rep* 2011; 60:1–24
  101. Kalil A: A silent killer: Cytomegalovirus infection in the non-immunocompromised critically ill patient. *Crit Care Med* 2008; 36:3261–3264
  102. Ziemann M, Sedemund-Adib B, Reiland P, et al: Increased mortality in long-term intensive care patients with active cytomegalovirus infection. *Crit Care Med* 2008; 36:3145–3150
  103. Hotchkiss RS, Opal S: Immunotherapy for sepsis—a new approach against an ancient foe. *N Engl J Med* 2010; 363:87–89
  104. Miller GG, Dummer JS: Herpes simplex and varicella zoster viruses: Forgotten but not gone. *Am J Transplant* 2007; 7:741–747
  105. Jimenez MF, Marshall JC; International Sepsis Forum: Source control in the management of sepsis. *Intensive Care Med* 2001; 27 Suppl 1:S49–S62
  106. Moss RL, Musemeche CA, Kosloske AM: Necrotizing fasciitis in children: Prompt recognition and aggressive therapy improve survival. *J Pediatr Surg* 1996; 31:1142–1146
  107. Boyer A, Vargas F, Coste F, et al: Influence of surgical treatment timing on mortality from necrotizing soft tissue infections requiring intensive care management. *Intensive Care Med* 2009; 35:847–853
  108. Bufalari A, Giustozzi G, Moggi L: Postoperative intraabdominal abscesses: Percutaneous versus surgical treatment. *Acta Chir Belg* 1996; 96:197–200
  109. O'Grady NP, Alexander M, Dellinger EP, et al: Guidelines for the prevention of intravascular catheter-related infections. Centers for Disease Control and Prevention. *MMWR Recomm Rep* 2002; 51(RR-10):1–29
  110. O'Grady NP, Alexander M, Dellinger EP, et al: Guidelines for the prevention of intravascular catheter-related infections. *Clin Infect Dis* 2002; 35:1281–1307
  111. Mier J, León EL, Castillo A, et al: Early versus late necrosectomy in severe necrotizing pancreatitis. *Am J Surg* 1997; 173:71–75
  112. van Santvoort HC, Besselink MG, Bakker OJ, et al; Dutch Pancreatitis Study Group: A step-up approach or open necrosectomy for necrotizing pancreatitis. *N Engl J Med* 2010; 362:1491–1502
  113. Evans A, Winslow EH: Oxygen saturation and hemodynamic response in critically ill, mechanically ventilated adults during intrahospital transport. *Am J Crit Care* 1995; 4:106–111
  114. Aitken LM, Williams G, Harvey M, et al: Nursing considerations to complement the Surviving Sepsis Campaign guidelines. *Crit Care Med* 2011; 39:1800–1818
  115. Liberati A, D'Amico R, Pifferi S, et al: Antibiotic prophylaxis to reduce respiratory tract infections and mortality in adults receiving intensive care. *Cochrane Collaboration* 2010; 9:1–72
  116. de Jonge E, Schultz MJ, Spanjaard L, et al: Effects of selective decontamination of digestive tract on mortality and acquisition of resistant bacteria in intensive care: A randomised controlled trial. *Lancet* 2003; 362:1011–1016
  117. de Smet AM, Kluytmans JA, Cooper BS, et al: Decontamination of the digestive tract and oropharynx in ICU patients. *N Engl J Med* 2009; 360:20–31
  118. Cuthbertson BH, Francis J, Campbell MK, et al; SuDDICU study groups: A study of the perceived risks, benefits and barriers to the use of SDD in adult critical care units (the SuDDICU study). *Trials* 2010; 11:117
  119. de Smet AM, Kluytmans JA, Blok HE, et al: Selective digestive tract decontamination and selective oropharyngeal decontamination and antibiotic resistance in patients in intensive-care units: An open-label, clustered group-randomised, crossover study. *Lancet Infect Dis* 2011; 11:372–380
  120. Oostdijk EA, de Smet AM, Blok HE, et al: Ecological effects of selective decontamination on resistant gram-negative bacterial colonization. *Am J Respir Crit Care Med* 2010; 181:452–457
  121. Ochoa-Ardila ME, Garcia-Cañas A, Gómez-Mediavilla K, et al: Long-term use of selective decontamination of the digestive tract does not

- increase antibiotic resistance: A 5-year prospective cohort study. *Intensive Care Med* 2011; 37:1458–1465
122. Guidet B, Martinet O, Boulain T, et al: Assessment of hemodynamic efficacy and safety of 6% hydroxyethylstarch 130/0.4 vs. 0.9% NaCl fluid replacement in patients with severe sepsis: The CRYSTMAS study. *Crit Care* 2012; 16:R94
  123. Perner A, Haase N, Guttormsen AB, et al; 6S Trial Group; Scandinavian Critical Care Trials Group: Hydroxyethyl starch 130/0.42 versus Ringer's acetate in severe sepsis. *N Engl J Med* 2012; 367:124–134
  124. Myburgh JA, Finfer S, Bellomo R, et al; CHEST Investigators; Australian and New Zealand Intensive Care Society Clinical Trials Group: Hydroxyethyl starch or saline for fluid resuscitation in intensive care. *N Engl J Med* 2012; 367:1901–1911
  125. Perel P, Roberts I: Colloids versus crystalloids for fluid resuscitation in critically ill patients. *Cochrane Database Syst Rev* 2011; 3: CD000567
  126. Schortgen F, Lacherade JC, Bruneel F, et al: Effects of hydroxyethylstarch and gelatin on renal function in severe sepsis: A multicentre randomised study. *Lancet* 2001; 357:911–916
  127. McIntyre LA, Fergusson D, Cook DJ, et al; Canadian Critical Care Trials Group: Fluid resuscitation in the management of early septic shock (FINESS): A randomized controlled feasibility trial. *Can J Anaesth* 2008; 55:819–826
  128. Brunkhorst FM, Engel C, Bloos F, et al; German Competence Network Sepsis (SepNet): Intensive insulin therapy and pentastarch resuscitation in severe sepsis. *N Engl J Med* 2008; 358:125–139
  129. Finfer S, Bellomo R, Boyce N, et al; SAFE Study Investigators: A comparison of albumin and saline for fluid resuscitation in the intensive care unit. *N Engl J Med* 2004; 350:2247–2256
  130. Delaney AP, Dan A, McCaffrey J, et al: The role of albumin as a resuscitation fluid for patients with sepsis: A systematic review and meta-analysis. *Crit Care Med* 2011; 39:386–391
  131. Marik PE, Monnet X, Teboul JL: Hemodynamic parameters to guide fluid therapy. *Ann Intensive Care* 2011; 1:1
  132. Marik PE, Cavallazzi R, Vasu T, et al: Dynamic changes in arterial waveform derived variables and fluid responsiveness in mechanically ventilated patients: A systematic review of the literature. *Crit Care Med* 2009; 37:2642–2647
  133. Hollenberg SM, Ahrens TS, Annane D, et al: Practice parameters for hemodynamic support of sepsis in adult patients: 2004 update. *Crit Care Med* 2004; 32:1928–1948
  134. LeDoux D, Astiz ME, Carpati CM, et al: Effects of perfusion pressure on tissue perfusion in septic shock. *Crit Care Med* 2000; 28:2729–2732
  135. Martin C, Papazian L, Perrin G, et al: Norepinephrine or dopamine for the treatment of hyperdynamic septic shock? *Chest* 1993; 103: 1826–1831
  136. Martin C, Viviani X, Leone M, et al: Effect of norepinephrine on the outcome of septic shock. *Crit Care Med* 2000; 28:2758–2765
  137. De Backer D, Creteur J, Silva E, et al: Effects of dopamine, norepinephrine, and epinephrine on the splanchnic circulation in septic shock: Which is best? *Crit Care Med* 2003; 31:1659–1667
  138. Day NP, Phu NH, Bethell DP, et al: The effects of dopamine and adrenaline infusions on acid-base balance and systemic haemodynamics in severe infection. *Lancet* 1996; 348:219–223
  139. Le Tulzo Y, Seguin P, Gacouin A, et al: Effects of epinephrine on right ventricular function in patients with severe septic shock and right ventricular failure: A preliminary descriptive study. *Intensive Care Med* 1997; 23:664–670
  140. Bollaert PE, Bauer P, Audibert G, et al: Effects of epinephrine on hemodynamics and oxygen metabolism in dopamine-resistant septic shock. *Chest* 1990; 98:949–953
  141. Zhou SX, Qiu HB, Huang YZ, et al: Effects of norepinephrine, epinephrine, and norepinephrine-dobutamine on systemic and gastric mucosal oxygenation in septic shock. *Acta Pharmacol Sin* 2002; 23:654–658
  142. Levy B, Bollaert PE, Charpentier C, et al: Comparison of norepinephrine and dobutamine to epinephrine for hemodynamics, lactate metabolism, and gastric tonometric variables in septic shock: A prospective, randomized study. *Intensive Care Med* 1997; 23:282–287
  143. Mackenzie SJ, Kapadia F, Nimmo GR, et al: Adrenaline in treatment of septic shock: Effects on haemodynamics and oxygen transport. *Intensive Care Med* 1991; 17:36–39
  144. Moran JL, O'Fathartaigh MS, Peisach AR, et al: Epinephrine as an inotropic agent in septic shock: A dose-profile analysis. *Crit Care Med* 1993; 21:70–77
  145. Yamazaki T, Shimada Y, Taenaka N, et al: Circulatory responses to afterloading with phenylephrine in hyperdynamic sepsis. *Crit Care Med* 1982; 10:432–435
  146. Gregory JS, Bonfiglio MF, Dasta JF, et al: Experience with phenylephrine as a component of the pharmacologic support of septic shock. *Crit Care Med* 1991; 19:1395–1400
  147. Annane D, Vignon P, Renault A, et al; CATS Study Group: Norepinephrine plus dobutamine versus epinephrine alone for management of septic shock: A randomised trial. *Lancet* 2007; 370:676–684
  148. Regnier B, Rapin M, Gory G, et al: Haemodynamic effects of dopamine in septic shock. *Intensive Care Med* 1977; 3:47–53
  149. Ruokonen E, Takala J, Kari A, et al: Regional blood flow and oxygen transport in septic shock. *Crit Care Med* 1993; 21:1296–1303
  150. Marik PE, Mohedin M: The contrasting effects of dopamine and norepinephrine on systemic and splanchnic oxygen utilization in hyperdynamic sepsis. *JAMA* 1994; 272:1354–1357
  151. Patel GP, Grahe JS, Sperry M, et al: Efficacy and safety of dopamine versus norepinephrine in the management of septic shock. *Shock* 2010; 33:375–380
  152. De Backer D, Biston P, Devriendt J, et al; SOAP II Investigators: Comparison of dopamine and norepinephrine in the treatment of shock. *N Engl J Med* 2010; 362:779–789
  153. De Backer D, Aldecoa C, Njimi H, et al: Dopamine versus norepinephrine in the treatment of septic shock: A meta-analysis\*. *Crit Care Med* 2012; 40:725–730
  154. Seguin P, Bellissant E, Le Tulzo Y, et al: Effects of epinephrine compared with the combination of dobutamine and norepinephrine on gastric perfusion in septic shock. *Clin Pharmacol Ther* 2002; 71:381–388
  155. Myburgh JA, Higgins A, Jovanovska A, et al; CAT Study investigators: A comparison of epinephrine and norepinephrine in critically ill patients. *Intensive Care Med* 2008; 34:2226–2234
  156. Morelli A, Ertmer C, Rehberg S, et al: Phenylephrine versus norepinephrine for initial hemodynamic support of patients with septic shock: A randomized, controlled trial. *Crit Care* 2008; 12:R143
  157. Landry DW, Levin HR, Gallant EM, et al: Vasopressin deficiency contributes to the vasodilation of septic shock. *Circulation* 1997; 95:1122–1125
  158. Patel BM, Chittock DR, Russell JA, et al: Beneficial effects of short-term vasopressin infusion during severe septic shock. *Anesthesiology* 2002; 96:576–582
  159. Dünser MW, Mayr AJ, Ulmer H, et al: Arginine vasopressin in advanced vasodilatory shock: A prospective, randomized, controlled study. *Circulation* 2003; 107:2313–2319
  160. Holmes CL, Patel BM, Russell JA, et al: Physiology of vasopressin relevant to management of septic shock. *Chest* 2001; 120:989–1002
  161. Malay MB, Ashton RC Jr, Landry DW, et al: Low-dose vasopressin in the treatment of vasodilatory septic shock. *J Trauma* 1999; 47:699–703; discussion 703
  162. Holmes CL, Walley KR, Chittock DR, et al: The effects of vasopressin on hemodynamics and renal function in severe septic shock: A case series. *Intensive Care Med* 2001; 27:1416–1421
  163. Lauzier F, Lévy B, Lamarre P, et al: Vasopressin or norepinephrine in early hyperdynamic septic shock: A randomized clinical trial. *Intensive Care Med* 2006; 32:1782–1789
  164. O'Brien A, Clapp L, Singer M: Terlipressin for norepinephrine-resistant septic shock. *Lancet* 2002; 359:1209–1210
  165. Sharshar T, Blanchard A, Paillard M, et al: Circulating vasopressin levels in septic shock. *Crit Care Med* 2003; 31:1752–1758

166. Russell JA, Walley KR, Singer J, et al; VASST Investigators: Vasopressin versus norepinephrine infusion in patients with septic shock. *N Engl J Med* 2008; 358:877–887
167. Dünser MW, Mayr AJ, Tür A, et al: Ischemic skin lesions as a complication of continuous vasopressin infusion in catecholamine-resistant vasodilatory shock: Incidence and risk factors. *Crit Care Med* 2003; 31:1394–1398
168. Albanèse J, Leone M, Delmas A, et al: Terlipressin or norepinephrine in hyperdynamic septic shock: A prospective, randomized study. *Crit Care Med* 2005; 33:1897–1902
169. Morelli A, Ertmer C, Lange M, et al: Effects of short-term simultaneous infusion of dobutamine and terlipressin in patients with septic shock: The DOBUPRESS study. *Br J Anaesth* 2008; 100:494–503
170. Morelli A, Ertmer C, Rehberg S, et al: Continuous terlipressin versus vasopressin infusion in septic shock (TERLIVAP): A randomized, controlled pilot study. *Crit Care* 2009; 13:R130
171. Bellomo R, Chapman M, Finfer S, et al: Low-dose dopamine in patients with early renal dysfunction: A placebo-controlled randomized trial. Australian and New Zealand Intensive Care Society (ANZICS) Clinical Trials Group. *Lancet* 2000; 356:2139–2143
172. Kellum JA, M Decker J: Use of dopamine in acute renal failure: A meta-analysis. *Crit Care Med* 2001; 29:1526–1531
173. Gattinoni L, Brazzi L, Pelosi P, et al: A trial of goal-oriented hemodynamic therapy in critically ill patients. Svo2 Collaborative Group. *N Engl J Med* 1995; 333:1025–1032
174. Hayes MA, Timmins AC, Yau EH, et al: Elevation of systemic oxygen delivery in the treatment of critically ill patients. *N Engl J Med* 1994; 330:1717–1722
175. Annane D, Sébille V, Charpentier C, et al: Effect of treatment with low doses of hydrocortisone and fludrocortisone on mortality in patients with septic shock. *JAMA* 2002; 288:862–871
176. Briegel J, Forst H, Haller M, et al: Stress doses of hydrocortisone reverse hyperdynamic septic shock: A prospective, randomized, double-blind, single-center study. *Crit Care Med* 1999; 27:723–732
177. Bollaert PE, Charpentier C, Levy B, et al: Reversal of late septic shock with supraphysiologic doses of hydrocortisone. *Crit Care Med* 1998; 26:645–650
178. Sprung CL, Annane D, Keh D, et al; CORTICUS Study Group: Hydrocortisone therapy for patients with septic shock. *N Engl J Med* 2008; 358:111–124
179. Annane D, Bellissant E, Bollaert PE, et al: Corticosteroids in the treatment of severe sepsis and septic shock in adults: A systematic review. *JAMA* 2009; 301:2362–2375
180. Sligl WI, Milner DA Jr, Sundar S, et al: Safety and efficacy of corticosteroids for the treatment of septic shock: A systematic review and meta-analysis. *Clin Infect Dis* 2009; 49:93–101
181. Patel GP, Balk RA: Systemic steroids in severe sepsis and septic shock. *Am J Respir Crit Care Med* 2012; 185:133–139
182. Oppert M, Schindler R, Husung C, et al: Low-dose hydrocortisone improves shock reversal and reduces cytokine levels in early hyperdynamic septic shock. *Crit Care Med* 2005; 33:2457–2464
183. Yildiz O, Doganay M, Aygen B, et al: Physiological-dose steroid therapy in sepsis [ISRCTN36253388]. *Crit Care* 2002; 6:251–259
184. Briegel J, Sprung CL, Annane D, et al; CORTICUS Study Group: Multicenter comparison of cortisol as measured by different methods in samples of patients with septic shock. *Intensive Care Med* 2009; 35:2151–2156
185. Allolio B, Dörr H, Stuttmann R, et al: Effect of a single bolus of etomidate upon eight major corticosteroid hormones and plasma ACTH. *Clin Endocrinol (Oxf)* 1985; 22:281–286
186. Jabre P, Combes X, Lapostolle F, et al; KETASED Collaborative Study Group: Etomidate versus ketamine for rapid sequence intubation in acutely ill patients: A multicentre randomised controlled trial. *Lancet* 2009; 374:293–300
187. Cuthbertson BH, Sprung CL, Annane D, et al: The effects of etomidate on adrenal responsiveness and mortality in patients with septic shock. *Intensive Care Med* 2009; 35:1868–1876
188. Keh D, Boehnke T, Weber-Cartens S, et al: Immunologic and hemodynamic effects of “low-dose” hydrocortisone in septic shock: A double-blind, randomized, placebo-controlled, crossover study. *Am J Respir Crit Care Med* 2003; 167:512–520
189. Huh JW, Choi HS, Lim CM, et al: Low-dose hydrocortisone treatment for patients with septic shock: A pilot study comparing 3 days with 7 days. *Respirology* 2011; 16:1088–1095
190. Confalonieri M, Urbino R, Potena A, et al: Hydrocortisone infusion for severe community-acquired pneumonia: A preliminary randomized study. *Am J Respir Crit Care Med* 2005; 171:242–248
191. Meijvis SC, Hardeman H, Remmelts HH, et al: Dexamethasone and length of hospital stay in patients with community-acquired pneumonia: A randomised, double-blind, placebo-controlled trial. *Lancet* 2011; 377:2023–2030
192. Weber-Carstens S, Deja M, Bercker S, et al: Impact of bolus application of low-dose hydrocortisone on glycemic control in septic shock patients. *Intensive Care Med* 2007; 33:730–733
193. Hébert PC, Wells G, Blajchman MA, et al: A multicenter, randomized, controlled clinical trial of transfusion requirements in critical care. Transfusion Requirements in Critical Care Investigators, Canadian Critical Care Trials Group. *N Engl J Med* 1999; 340:409–417
194. Hajar LA, Vincent JL, Galas FR, et al: Transfusion requirements after cardiac surgery: The TRACS randomized controlled trial. *JAMA* 2010; 304:1559–1567
195. Marik PE, Sibbald WJ: Effect of stored-blood transfusion on oxygen delivery in patients with sepsis. *JAMA* 1993; 269:3024–3029
196. Lorente JA, Landin L, De Pablo R, et al: Effects of blood transfusion on oxygen transport variables in severe sepsis. *Crit Care Med* 1993; 21:1312–1318
197. Fernandes CJ Jr, Akamine N, De Marco FV, et al: Red blood cell transfusion does not increase oxygen consumption in critically ill septic patients. *Crit Care* 2001; 5:362–367
198. Corwin HL, Gettinger A, Rodriguez RM, et al: Efficacy of recombinant human erythropoietin in the critically ill patient: A randomized, double-blind, placebo-controlled trial. *Crit Care Med* 1999; 27:2346–2350
199. Corwin HL, Gettinger A, Pearl RG, et al; EPO Critical Care Trials Group: Efficacy of recombinant human erythropoietin in critically ill patients: A randomized controlled trial. *JAMA* 2002; 288:2827–2835
200. College of American Pathologists: Practice parameter for the use of fresh-frozen plasma, cryoprecipitate, and platelets. *JAMA* 1994; 271:777–781
201. Canadian Medical Association Expert Working Group: Guidelines for red blood cell and plasma transfusion for adults and children. *Can Med Assoc J* 1997; 156:S1–S24
202. American Society of Anaesthesiologists Task Force on Blood Component Therapy: Practice guidelines for blood component therapy. *Anesthesiology* 1996; 84:732–747
203. Liumbruno G, Bennardello F, Lattanzio A, et al; Italian Society of Transfusion Medicine and Immunohaematology (SIMITI) Work Group: Recommendations for the transfusion of plasma and platelets. *Blood Transfus* 2009; 7:132–150
204. Abdel-Wahab OI, Healy B, Dzik WH: Effect of fresh-frozen plasma transfusion on prothrombin time and bleeding in patients with mild coagulation abnormalities. *Transfusion* 2006; 46:1279–1285
205. Stanworth SJ, Walsh TS, Prescott RJ, et al; Intensive Care Study of Coagulopathy (ISOC) investigators: A national study of plasma use in critical care: Clinical indications, dose and effect on prothrombin time. *Crit Care* 2011; 15:R108
206. Warren BL, Eid A, Singer P, et al; KyberSept Trial Study Group: Caring for the critically ill patient. High-dose antithrombin III in severe sepsis: A randomized controlled trial. *JAMA* 2001; 286:1869–1878
207. Wiedermann CJ, Hoffmann JN, Juers M, et al; KyberSept Investigators: High-dose antithrombin III in the treatment of severe sepsis in patients with a high risk of death: Efficacy and safety. *Crit Care Med* 2006; 34:285–292
208. Schiffer CA, Anderson KC, Bennett CL, et al; American Society of Clinical Oncology: Platelet transfusion for patients with cancer: Clinical practice guidelines of the American Society of Clinical Oncology. *J Clin Oncol* 2001; 19:1519–1538



209. Guidelines for the use of platelet transfusions. *Br J Haematol* 2003; 122:10–23
210. Werdan K, Pilz G, Bujdoso O, et al; Score-Based Immunoglobulin Therapy of Sepsis (SBITS) Study Group: Score-based immunoglobulin G therapy of patients with sepsis: The SBITS study. *Crit Care Med* 2007; 35:2693–2701
211. Brocklehurst P, Farrell B, King A, et al; INIS Collaborative Group: Treatment of neonatal sepsis with intravenous immune globulin. *N Engl J Med* 2011; 365:1201–1211
212. Alejandria MM, Lansang MA, Dans LF, et al: Intravenous immunoglobulin for treating sepsis and septic shock. *Cochrane Database Syst Rev* 2002; 1: CD001090
213. Burns ER, Lee V, Rubinstein A: Treatment of septic thrombocytopenia with immune globulin. *J Clin Immunol* 1991; 11:363–368
214. Darenberg J, Ihendyane N, Sjölin J, et al; Streptlg Study Group: Intravenous immunoglobulin G therapy in streptococcal toxic shock syndrome: A European randomized, double-blind, placebo-controlled trial. *Clin Infect Dis* 2003; 37:333–340
215. Hentrich M, Fehle K, Ostermann H, et al: IgMA-enriched immunoglobulin in neutropenic patients with sepsis syndrome and septic shock: A randomized, controlled, multiple-center trial. *Crit Care Med* 2006; 34:1319–1325
216. Rodríguez A, Rello J, Neira J, et al: Effects of high-dose of intravenous immunoglobulin and antibiotics on survival for severe sepsis undergoing surgery. *Shock* 2005; 23:298–304
217. Pildal J, Gøtzsche PC: Polyclonal immunoglobulin for treatment of bacterial sepsis: A systematic review. *Clin Infect Dis* 2004; 39:38–46
218. Laupland KB, Kirkpatrick AW, Delaney A: Polyclonal intravenous immunoglobulin for the treatment of severe sepsis and septic shock in critically ill adults: A systematic review and meta-analysis. *Crit Care Med* 2007; 35:2686–2692
219. Kreymann KG, de Heer G, Nierhaus A, et al: Use of polyclonal immunoglobulins as adjunctive therapy for sepsis or septic shock. *Crit Care Med* 2007; 35:2677–2685
220. Turgeon AF, Hutton B, Fergusson DA, et al: Meta-analysis: Intravenous immunoglobulin in critically ill adult patients with sepsis. *Ann Intern Med* 2007; 146:193–203
221. Angstwurm MW, Engelmann L, Zimmermann T, et al: Selenium in Intensive Care (SIC): Results of a prospective randomized, placebo-controlled, multiple-center study in patients with severe systemic inflammatory response syndrome, sepsis, and septic shock. *Crit Care Med* 2007; 35:118–126
222. Forceville X, Laviolle B, Annane D, et al: Effects of high doses of selenium, as sodium selenite, in septic shock: A placebo-controlled, randomized, double-blind, phase II study. *Crit Care* 2007; 11:R73
223. Manzanares W, Biestro A, Torre MH, et al: High-dose selenium reduces ventilator-associated pneumonia and illness severity in critically ill patients with systemic inflammation. *Intensive Care Med* 2011; 37:1120–1127
224. Berger MM, Eggimann P, Heyland DK, et al: Reduction of nosocomial pneumonia after major burns by trace element supplementation: Aggregation of two randomised trials. *Crit Care* 2006; 10:R153
225. Mishra V, Baines M, Perry SE, et al: Effect of selenium supplementation on biochemical markers and outcome in critically ill patients. *Clin Nutr* 2007; 26:41–50
226. Andrews PJ, Avenell A, Noble DW, et al; Scottish Intensive care Glutamine or selenium Evaluative Trial Trials Group: Randomised trial of glutamine, selenium, or both, to supplement parenteral nutrition for critically ill patients. *BMJ* 2011; 342:d1542
227. Wang Z, Forceville X, Van Antwerpen P, et al: A large-bolus injection, but not continuous infusion of sodium selenite improves outcome in peritonitis. *Shock* 2009; 32:140–146
228. Bernard GR, Vincent JL, Laterre PF, et al; Recombinant human protein C Worldwide Evaluation in Severe Sepsis (PROWESS) study group: Efficacy and safety of recombinant human activated protein C for severe sepsis. *N Engl J Med* 2001; 344:699–709
229. Abraham E, Laterre PF, Garg R, et al; Administration of Drotrecogin Alfa (Activated) in Early Stage Severe Sepsis (ADDRESS) Study Group: Drotrecogin alfa (activated) for adults with severe sepsis and a low risk of death. *N Engl J Med* 2005; 353:1332–1341
230. Nadel S, Goldstein B, Williams MD, et al; REsearching severe Sepsis and Organ dysfunction in children: a gLocal perspective (RESOLVE) study group: Drotrecogin alfa (activated) in children with severe sepsis: A multicentre phase III randomised controlled trial. *Lancet* 2007; 369:836–843
231. <http://www.fda.gov/Drugs/DrugSafety/DrugSafetyPodcasts/ucm277212.htm>. Accessed December 18, 2011
232. Bernard GR, Artigas A, Brigham KL, et al: The American-European Consensus Conference on ARDS. Definitions, mechanisms, relevant outcomes, and clinical trial coordination. *Am J Respir Crit Care Med* 1994; 149(3 Pt 1):818–824
233. Ranieri VM, Rubenfeld GD, Thompson BT, et al: Acute respiratory distress syndrome: The Berlin definition. *JAMA* 2012; 307:2522–2523
234. Acute Respiratory Distress Syndrome Network: Ventilation with lower tidal volumes as compared with traditional tidal volumes for acute lung injury and the acute respiratory distress syndrome. *N Engl J Med* 2000; 342:1301–1308
235. Amato MB, Barbas CS, Medeiros DM, et al: Effect of a protective-ventilation strategy on mortality in the acute respiratory distress syndrome. *N Engl J Med* 1998; 338:347–354
236. Brochard L, Roudot-Thoraval F, Roupie E, et al: Tidal volume reduction for prevention of ventilator-induced lung injury in acute respiratory distress syndrome. The Multicenter Trial Group on Tidal Volume reduction in ARDS. *Am J Respir Crit Care Med* 1998; 158:1831–1838
237. Brower RG, Shanholtz CB, Fessler HE, et al: Prospective, randomized, controlled clinical trial comparing traditional versus reduced tidal volume ventilation in acute respiratory distress syndrome patients. *Crit Care Med* 1999; 27:1492–1498
238. Stewart TE, Meade MO, Cook DJ, et al: Evaluation of a ventilation strategy to prevent barotrauma in patients at high risk for acute respiratory distress syndrome. Pressure- and Volume-Limited Ventilation Strategy Group. *N Engl J Med* 1998; 338:355–361
239. Eichacker PQ, Gerstenberger EP, Banks SM, et al: Meta-analysis of acute lung injury and acute respiratory distress syndrome trials testing low tidal volumes. *Am J Respir Crit Care Med* 2002; 166:1510–1514
240. Putensen C, Theuerkauf N, Zinserling J, et al: Meta-analysis: Ventilation strategies and outcomes of the acute respiratory distress syndrome and acute lung injury. *Ann Intern Med* 2009; 151:566–576
241. Burns KE, Adhikari NK, Slutsky AS, et al: Pressure and volume limited ventilation for the ventilatory management of patients with acute lung injury: A systematic review and meta-analysis. *PLoS ONE* 2011; 6:e14623
242. Tobin MJ: Culmination of an era in research on the acute respiratory distress syndrome. *N Engl J Med* 2000; 342:1360–1361
243. Marini JJ, Gattinoni L: Ventilatory management of acute respiratory distress syndrome: A consensus of two. *Crit Care Med* 2004; 32:250–255
244. Hager DN, Krishnan JA, Hayden DL, et al; ARDS Clinical Trials Network: Tidal volume reduction in patients with acute lung injury when plateau pressures are not high. *Am J Respir Crit Care Med* 2005; 172:1241–1245
245. Checkley W, Brower R, Korpak A, et al; Acute Respiratory Distress Syndrome Network Investigators: Effects of a clinical trial on mechanical ventilation practices in patients with acute lung injury. *Am J Respir Crit Care Med* 2008; 177:1215–1222
246. Kallet RH, Jasmer RM, Luce JM, et al: The treatment of acidosis in acute lung injury with tris-hydroxymethyl aminomethane (THAM). *Am J Respir Crit Care Med* 2000; 161(4 Pt 1):1149–1153
247. Weber T, Tschernich H, Sitzwohl C, et al: Tromethamine buffer modifies the depressant effect of permissive hypercapnia on myocardial contractility in patients with acute respiratory distress syndrome. *Am J Respir Crit Care Med* 2000; 162(4 Pt 1):1361–1365
248. Determann RM, Royakkers A, Wolthuis EK, et al: Ventilation with lower tidal volumes as compared with conventional tidal volumes



- for patients without acute lung injury: A preventive randomized controlled trial. *Crit Care* 2010; 14:R1
249. Yilmaz M, Keegan MT, Iscimen R, et al: Toward the prevention of acute lung injury: Protocol-guided limitation of large tidal volume ventilation and inappropriate transfusion. *Crit Care Med* 2007; 35:1660–6; quiz 1667
  250. Gajic O, Dara SI, Mendez JL, et al: Ventilator-associated lung injury in patients without acute lung injury at the onset of mechanical ventilation. *Crit Care Med* 2004; 32:1817–1824
  251. Schultz MJ: Lung-protective mechanical ventilation with lower tidal volumes in patients not suffering from acute lung injury: A review of clinical studies. *Med Sci Monit* 2008; 14:RA22–RA26
  252. Marini JJ, Ravenscraft SA: Mean airway pressure: Physiologic determinants and clinical importance—Part 1: Physiologic determinants and measurements. *Crit Care Med* 1992; 20:1461–1472
  253. Gattinoni L, Marcolin R, Caspani ML, et al: Constant mean airway pressure with different patterns of positive pressure breathing during the adult respiratory distress syndrome. *Bull Eur Physiopathol Respir* 1985; 21:275–279
  254. Pesenti A, Marcolin R, Prato P, et al: Mean airway pressure vs. positive end-expiratory pressure during mechanical ventilation. *Crit Care Med* 1985; 13:34–37
  255. Mercat A, Richard JC, Vielle B, et al; Expiratory Pressure (Express) Study Group: Positive end-expiratory pressure setting in adults with acute lung injury and acute respiratory distress syndrome: A randomized controlled trial. *JAMA* 2008; 299:646–655
  256. Meade MO, Cook DJ, Guyatt GH, et al; Lung Open Ventilation Study Investigators: Ventilation strategy using low tidal volumes, recruitment maneuvers, and high positive end-expiratory pressure for acute lung injury and acute respiratory distress syndrome: A randomized controlled trial. *JAMA* 2008; 299:637–645
  257. Brower RG, Lanken PN, MacIntyre N, et al; National Heart, Lung, and Blood Institute ARDS Clinical Trials Network: Higher versus lower positive end-expiratory pressures in patients with the acute respiratory distress syndrome. *N Engl J Med* 2004; 351:327–336
  258. Briel M, Meade M, Mercat A, et al: Higher vs lower positive end-expiratory pressure in patients with acute lung injury and acute respiratory distress syndrome: Systematic review and meta-analysis. *JAMA* 2010; 303:865–873
  259. Amato MB, Barbas CS, Medeiros DM, et al: Beneficial effects of the “open lung approach” with low distending pressures in acute respiratory distress syndrome. A prospective randomized study on mechanical ventilation. *Am J Respir Crit Care Med* 1995; 152(6 Pt 1):1835–1846
  260. Gattinoni L, Caironi P, Cressoni M, et al: Lung recruitment in patients with the acute respiratory distress syndrome. *N Engl J Med* 2006; 354:1775–1786
  261. Pieling MR, Fan E: Therapies for refractory hypoxemia in acute respiratory distress syndrome. *JAMA* 2010; 304:2521–2527
  262. Fan E, Wilcox ME, Brower RG, et al: Recruitment maneuvers for acute lung injury: A systematic review. *Am J Respir Crit Care Med* 2008; 178:1156–1163
  263. Stocker R, Neff T, Stein S, et al: Prone positioning and low-volume pressure-limited ventilation improve survival in patients with severe ARDS. *Chest* 1997; 111:1008–1017
  264. Lamm WJ, Graham MM, Albert RK: Mechanism by which the prone position improves oxygenation in acute lung injury. *Am J Respir Crit Care Med* 1994; 150:184–193
  265. Joliet P, Bulpa P, Chevolet JC: Effects of the prone position on gas exchange and hemodynamics in severe acute respiratory distress syndrome. *Crit Care Med* 1998; 26:1977–1985
  266. Guerin C, Gaillard S, Lemasson S, et al: Effects of systematic prone positioning in hypoxemic acute respiratory failure: A randomized controlled trial. *JAMA* 2004; 292:2379–2387
  267. Taccone P, Pesenti A, Latini R, et al; Prone-Supine II Study Group: Prone positioning in patients with moderate and severe acute respiratory distress syndrome: A randomized controlled trial. *JAMA* 2009; 302:1977–1984
  268. Mancebo J, Fernández R, Blanch L, et al: A multicenter trial of prolonged prone ventilation in severe acute respiratory distress syndrome. *Am J Respir Crit Care Med* 2006; 173:1233–1239
  269. Gattinoni L, Tognoni G, Pesenti A, et al; Prone-Supine Study Group: Effect of prone positioning on the survival of patients with acute respiratory failure. *N Engl J Med* 2001; 345:568–573
  270. Sud S, Friedrich JO, Taccone P, et al: Prone ventilation reduces mortality in patients with acute respiratory failure and severe hypoxemia: Systematic review and meta-analysis. *Intensive Care Med* 2010; 36:585–599
  271. Sud S, Sud M, Friedrich JO, et al: High frequency oscillation in patients with acute lung injury and acute respiratory distress syndrome (ARDS): Systematic review and meta-analysis. *BMJ* 2010; 340:c2327
  272. Noah MA, Peek GJ, Finney SJ, et al: Referral to an extracorporeal membrane oxygenation center and mortality among patients with severe 2009 influenza A(H1N1). *JAMA* 2011; 306:1659–1668
  273. Checkley W: Extracorporeal membrane oxygenation as a first-line treatment strategy for ARDS: Is the evidence sufficiently strong? *JAMA* 2011; 306:1703–1704
  274. Peek GJ, Mugford M, Tiruvoipati R, et al; CESAR Trial Collaboration: Efficacy and economic assessment of conventional ventilatory support versus extracorporeal membrane oxygenation for severe adult respiratory failure (CESAR): A multicentre randomised controlled trial. *Lancet* 2009; 374:1351–1363
  275. Adhikari NK, Burns KE, Friedrich JO, et al: Effect of nitric oxide on oxygenation and mortality in acute lung injury: Systematic review and meta-analysis. *BMJ* 2007; 334:779
  276. Drakulovic MB, Torres A, Bauer TT, et al: Supine body position as a risk factor for nosocomial pneumonia in mechanically ventilated patients: A randomized trial. *Lancet* 1999; 354:1851–1858
  277. van Nieuwenhoven CA, Vandenbroucke-Grauls C, van Tiel FH, et al: Feasibility and effects of the semirecumbent position to prevent ventilator-associated pneumonia: A randomized study. *Crit Care Med* 2006; 34:396–402
  278. Antonelli M, Conti G, Rocco M, et al: A comparison of noninvasive positive-pressure ventilation and conventional mechanical ventilation in patients with acute respiratory failure. *N Engl J Med* 1998; 339:429–435
  279. Ferrer M, Esquinas A, Leon M, et al: Noninvasive ventilation in severe hypoxemic respiratory failure: A randomized clinical trial. *Am J Respir Crit Care Med* 2003; 168:1438–1444
  280. Rana S, Jenad H, Gay PC, et al: Failure of non-invasive ventilation in patients with acute lung injury: Observational cohort study. *Crit Care* 2006; 10:R79
  281. Domenighetti G, Moccia A, Gayer R: Observational case-control study of non-invasive ventilation in patients with ARDS. *Monaldi Arch Chest Dis* 2008; 69:5–10
  282. Ely W, Baker AB, Dunagen DP: Effect on the duration of mechanical ventilation of identifying patients capable of breathing spontaneously. *New Engl J Med* 1996; 335:1865–1869
  283. Kress JP, Pohlman AS, O'Connor MF, et al: Daily interruption of sedative infusions in critically ill patients undergoing mechanical ventilation. *N Engl J Med* 2000; 342:1471–1477
  284. Girard TD, Kress JP, Fuchs BD, et al: Efficacy and safety of a paired sedation and ventilator weaning protocol for mechanically ventilated patients in intensive care (Awakening and Breathing Controlled trial): A randomised controlled trial. *Lancet* 2008; 371:126–134
  285. Iberti TJ, Fischer EP, Leibowitz AB, et al: A multicenter study of physicians' knowledge of the pulmonary artery catheter. Pulmonary Artery Catheter Study Group. *JAMA* 1990; 264:2928–2932
  286. Al-Kharrat T, Zarich S, Amoateng-Adjepong Y, et al: Analysis of observer variability in measurement of pulmonary artery occlusion pressures. *Am J Respir Crit Care Med* 1999; 160:415–420
  287. Connors AF Jr, McCaffree DR, Gray BA: Evaluation of right-heart catheterization in the critically ill patient without acute myocardial infarction. *N Engl J Med* 1983; 308:263–267
  288. Osman D, Ridol C, Ray P, et al: Cardiac filling pressures are not appropriate to predict hemodynamic response to volume challenge. *Crit Care Med* 2007; 35:64–68

289. Richard C, Warszawski J, Anguel N, et al; French Pulmonary Artery Catheter Study Group: Early use of the pulmonary artery catheter and outcomes in patients with shock and acute respiratory distress syndrome: A randomized controlled trial. *JAMA* 2003; 290:2713–2720
290. National Heart, Lung, and Blood Institute Acute Respiratory Distress Syndrome (ARDS) Clinical Trials Network; Wheeler AP, Bernard GR, Thompson BT, et al: Pulmonary-artery versus central venous catheter to guide treatment of acute lung injury. *N Engl J Med* 2006; 354:2213–2224
291. Sandham JD, Hull RD, Brant RF, et al; Canadian Critical Care Clinical Trials Group: A randomized, controlled trial of the use of pulmonary-artery catheters in high-risk surgical patients. *N Engl J Med* 2003; 348: 5–14
292. Shah MR, Hasselblad V, Stevenson LW, et al: Impact of the pulmonary artery catheter in critically ill patients: Meta-analysis of randomized clinical trials. *JAMA* 2005; 294:1664–1670
293. Harvey S, Harrison DA, Singer M, et al; PAC-Man study collaboration: Assessment of the clinical effectiveness of pulmonary artery catheters in management of patients in intensive care (PAC-Man): A randomised controlled trial. *Lancet* 2005; 366:472–477
294. Harvey S, Young D, Brampton W, et al: Pulmonary artery catheters for adult patients in intensive care. *Cochrane Database Syst Rev* 2006; CD003408
295. Sibbald WJ, Short AK, Warshawski FJ, et al: Thermal dye measurements of extravascular lung water in critically ill patients. Intravascular Starling forces and extravascular lung water in the adult respiratory distress syndrome. *Chest* 1985; 87:585–592
296. Martin GS, Mangialardi RJ, Wheeler AP, et al: Albumin and furosemide therapy in hypoproteinemic patients with acute lung injury. *Crit Care Med* 2002; 30:2175–2182
297. Mitchell JP, Schuller D, Calandrino FS, et al: Improved outcome based on fluid management in critically ill patients requiring pulmonary artery catheterization. *Am Rev Respir Dis* 1992; 145:990–998
298. Schuller D, Mitchell JP, Calandrino FS, et al: Fluid balance during pulmonary edema. Is fluid gain a marker or a cause of poor outcome? *Chest* 1991; 100:1068–1075
299. National Heart, Lung, and Blood Institute Acute Respiratory Distress Syndrome (ARDS) Clinical Trials Network; Wiedemann HP, Wheeler AP, Bernard GR, et al: Comparison of two fluid-management strategies in acute lung injury. *N Engl J Med* 2006; 354:2564–2575
300. Perkins GD, McAuley DF, Thickett DR, et al: The beta-agonist lung injury trial (BALTI): A randomized placebo-controlled clinical trial. *Am J Respir Crit Care Med* 2006; 173:281–287
301. Matthay MA, Brower RG, Carson S, et al: Randomized, placebo-controlled clinical trial of an aerosolized  $\beta$ -2 agonist for treatment of acute lung injury. *Am J Respir Crit Care Med* 2011; 184:561–568
302. Gao Smith F, Perkins GD, Gates S, et al; BALTI-2 study investigators: Effect of intravenous  $\beta$ -2 agonist treatment on clinical outcomes in acute respiratory distress syndrome (BALTI-2): A multicentre, randomised controlled trial. *Lancet* 2012; 379:229–235
303. Marx WH, DeMaintenon NL, Mooney KF, et al: Cost reduction and outcome improvement in the intensive care unit. *J Trauma* 1999; 46:625–9; discussion 629
304. MacLaren R, Plamondon JM, Ramsay KB, et al: A prospective evaluation of empiric versus protocol-based sedation and analgesia. *Pharmacotherapy* 2000; 20:662–672
305. Brook AD, Ahrens TS, Schaiff R, et al: Effect of a nursing-implemented sedation protocol on the duration of mechanical ventilation. *Crit Care Med* 1999; 27:2609–2615
306. Shehabi Y, Bellomo R, Reade MC: Early intensive care sedation predicts long-term mortality in ventilated critically ill patients. *Am J Respir Crit Care Med* 2012; 186:724–731
307. Strøm T, Martinussen T, Toft P: A protocol of no sedation for critically ill patients receiving mechanical ventilation: A randomised trial. *Lancet* 2010; 375:475–480
308. Devlin JW, Boleski G, Mlynarek M, et al: Motor Activity Assessment Scale: A valid and reliable sedation scale for use with mechanically ventilated patients in an adult surgical intensive care unit. *Crit Care Med* 1999; 27:1271–1275
309. De Jonghe B, Cook D, Sharshar T, et al: Acquired neuromuscular disorders in critically ill patients: A systematic review. Groupe de Reflexion et d'Etude sur les Neuromyopathies En Reanimation. *Intensive Care Med* 1998; 24:1242–1250
310. Kollef MH, Levy NT, Ahrens TS, et al: The use of continuous i.v. sedation is associated with prolongation of mechanical ventilation. *Chest* 1998; 114:541–548
311. Mehta S, Burry L, Cook D, et al, SLEAP Investigators; Canadian Critical Care Trials Group: Daily sedation interruption in mechanically ventilated critically ill patients cared for with a sedation protocol: a randomized controlled trial. *JAMA* 2012; 308:1985–1992
312. Kress JP, Vinayak AG, Levitt J, et al: Daily sedative interruption in mechanically ventilated patients at risk for coronary artery disease. *Crit Care Med* 2007; 35:365–371
313. Schweickert WD, Pohlman MC, Pohlman AS, et al: Early physical and occupational therapy in mechanically ventilated, critically ill patients: A randomised controlled trial. *Lancet* 2009; 373:1874–1882
314. Klessig HT, Geiger HJ, Murray MJ, et al: A national survey on the practice patterns of anesthesiologist intensivists in the use of muscle relaxants. *Crit Care Med* 1992; 20:1341–1345
315. Murray MJ, Cowen J, DeBlock H, et al; Task Force of the American College of Critical Care Medicine (ACCM) of the Society of Critical Care Medicine (SCCM), American Society of Health-System Pharmacists, American College of Chest Physicians: Clinical practice guidelines for sustained neuromuscular blockade in the adult critically ill patient. *Crit Care Med* 2002; 30:142–156
316. Hansen-Flaschen JH, Brazinsky S, Basile C, et al: Use of sedating drugs and neuromuscular blocking agents in patients requiring mechanical ventilation for respiratory failure. A national survey. *JAMA* 1991; 266:2870–2875
317. Freebairn RC, Derrick J, Gomersall CD, et al: Oxygen delivery, oxygen consumption, and gastric intramucosal pH are not improved by a computer-controlled, closed-loop, vecuronium infusion in severe sepsis and septic shock. *Crit Care Med* 1997; 25:72–77
318. Papazian L, Forel JM, Gacouin A, et al; ACURASYS Study Investigators: Neuromuscular blockers in early acute respiratory distress syndrome. *N Engl J Med* 2010; 363:1107–1116
319. Forel JM, Roch A, Marin V, et al: Neuromuscular blocking agents decrease inflammatory response in patients presenting with acute respiratory distress syndrome. *Crit Care Med* 2006; 34:2749–2757
320. Shapiro BA, Warren J, Egol AB, et al: Practice parameters for sustained neuromuscular blockade in the adult critically ill patient: An executive summary. Society of Critical Care Medicine. *Crit Care Med* 1995; 23:1601–1605
321. Meyer KC, Prielipp RC, Grossman JE, et al: Prolonged weakness after infusion of atracurium in two intensive care unit patients. *Anesth Analg* 1994; 78:772–774
322. Lacomis D, Petrella JT, Giuliani MJ: Causes of neuromuscular weakness in the intensive care unit: A study of ninety-two patients. *Muscle Nerve* 1998; 21:610–617
323. Rudis MI, Sikora CA, Angus E, et al: A prospective, randomized, controlled evaluation of peripheral nerve stimulation versus standard clinical dosing of neuromuscular blocking agents in critically ill patients. *Crit Care Med* 1997; 25:575–583
324. Frankel H, Jeng J, Tilly E, et al: The impact of implementation of neuromuscular blockade monitoring standards in a surgical intensive care unit. *Am Surg* 1996; 62:503–506
325. Strange C, Vaughan L, Franklin C, et al: Comparison of train-of-four and best clinical assessment during continuous paralysis. *Am J Respir Crit Care Med* 1997; 156:1556–1561
326. van den Berghe G, Wouters P, Weekers F, et al: Intensive insulin therapy in critically ill patients. *N Engl J Med* 2001; 345:1359–1367
327. Van den Berghe G, Wilmer A, Hermans G, et al: Intensive insulin therapy in the medical ICU. *N Engl J Med* 2006; 354:449–461
328. Arabi YM, Dabbagh OC, Tamim HM, et al: Intensive versus conventional insulin therapy: A randomized controlled trial in medical and surgical critically ill patients. *Crit Care Med* 2008; 36:3190–3197
329. De La Rosa GDC, Hernando Donado J, Restrepo AH: Strict glycaemic control in patients hospitalised in a mixed medical and surgical

- intensive care unit: A randomised clinical trial. *Critical Care* 2008; 12:R120
330. Annane D, Cariou A, Maxime V, et al; COITSS Study Investigators: Corticosteroid treatment and intensive insulin therapy for septic shock in adults: A randomized controlled trial. *JAMA* 2010; 303:341–348
  331. The NICE-SUGAR Study Investigators: Intensive versus conventional glucose control in critically ill patients. *N Engl J Med* 2009; 360:1283–1297
  332. Preiser JC, Devos P, Ruiz-Santana S, et al: A prospective randomised multi-centre controlled trial on tight glucose control by intensive insulin therapy in adult intensive care units: The Glucontrol study. *Intensive Care Med* 2009; 35:1738–1748
  333. Wiener RS, Wiener DC, Larson RJ: Benefits and risks of tight glucose control in critically ill adults: A meta-analysis. *JAMA* 2008; 300:933–944
  334. Griesdale DE, de Souza RJ, van Dam RM, et al: Intensive insulin therapy and mortality among critically ill patients: A meta-analysis including NICE-SUGAR study data. *CMAJ* 2009; 180:821–827
  335. Marik PE, Preiser JC: Toward understanding tight glycemic control in the ICU: A systematic review and metaanalysis. *Chest* 2010; 137:544–551
  336. Friedrich JO, Chant C, Adhikari NK: Does intensive insulin therapy really reduce mortality in critically ill surgical patients? A reanalysis of meta-analytic data. *Crit Care* 2010; 14:324
  337. Kansagara D, Fu R, Freeman M, et al: Intensive insulin therapy in hospitalized patients: A systematic review. *Ann Intern Med* 2011; 154:268–282
  338. Peberdy MA, Callaway CW, Neumar RW, et al: Part 9: post-cardiac arrest care: 2010 American Heart Association Guidelines for Cardiopulmonary Resuscitation and Emergency Cardiovascular Care. *Circulation* 2010; 122(18 Suppl 3):S768–S786
  339. Qaseem A, Humphrey LL, Chou R, et al; Clinical Guidelines Committee of the American College of Physicians: Use of intensive insulin therapy for the management of glycemic control in hospitalized patients: A clinical practice guideline from the American College of Physicians. *Ann Intern Med* 2011; 154:260–267
  340. Moghissi ES, Korytkowski MT, DiNardo M, et al; American Association of Clinical Endocrinologists; American Diabetes Association: American Association of Clinical Endocrinologists and American Diabetes Association consensus statement on inpatient glycemic control. *Diabetes Care* 2009; 32:1119–1131
  341. Jacobi J, Bircher N, Krinsley J, et al: Guidelines for the use of an insulin infusion for the management of hyperglycemia in critically ill patients. *Crit Care Med* 2012; 40:3251–3276
  342. Kauffmann RM, Hayes RM, Jenkins JM, et al: Provision of balanced nutrition protects against hypoglycemia in the critically ill surgical patient. *JPEN J Parenter Enteral Nutr* 2011; 35:686–694
  343. Egi M, Bellomo R, Stachowski E, et al: Variability of blood glucose concentration and short-term mortality in critically ill patients. *Anesthesiology* 2006; 105:244–252
  344. Krinsley JS: Glycemic variability: A strong independent predictor of mortality in critically ill patients. *Crit Care Med* 2008; 36:3008–3013
  345. Mackenzie IM, Whitehouse T, Nightingale PG: The metrics of glycaemic control in critical care. *Intensive Care Med* 2011; 37:435–443
  346. Egi M, Bellomo R, Stachowski E, et al: Blood glucose concentration and outcome of critical illness: The impact of diabetes. *Crit Care Med* 2008; 36:2249–2255
  347. Krinsley JS: Glycemic variability and mortality in critically ill patients: The impact of diabetes. *J Diabetes Sci Technol* 2009; 3:1292–1301
  348. Nichols JH: Bedside testing, glucose monitoring, and diabetes management. In: *Principles of Point of Care Testing*. Kost GJ (Ed). Philadelphia, Lippincott Williams & Wilkins, 2002
  349. Kanji S, Buffie J, Hutton B, et al: Reliability of point-of-care testing for glucose measurement in critically ill adults. *Crit Care Med* 2005; 33:2778–2785
  350. Hoedemaekers CW, Klein Gunnewiek JM, Prinsen MA, et al: Accuracy of bedside glucose measurement from three glucometers in critically ill patients. *Crit Care Med* 2008; 36:3062–3066
  351. Khan AI, Vasquez Y, Gray J, et al: The variability of results between point-of-care testing glucose meters and the central laboratory analyzer. *Arch Pathol Lab Med* 2006; 130:1527–1532
  352. Desachy A, Vuagnat AC, Ghazali AD, et al: Accuracy of bedside glucometry in critically ill patients: Influence of clinical characteristics and perfusion index. *Mayo Clin Proc* 2008; 83:400–405
  353. Fekih Hassen M, Ayed S, Gharbi R, et al: Bedside capillary blood glucose measurements in critically ill patients: Influence of catecholamine therapy. *Diabetes Res Clin Pract* 2010; 87:87–91
  354. Wilson M, Weinreb J, Hoo GW: Intensive insulin therapy in critical care: A review of 12 protocols. *Diabetes Care* 2007; 30:1005–1011
  355. Newton CA, Smiley D, Bode BW, et al: A comparison study of continuous insulin infusion protocols in the medical intensive care unit: Computer-guided vs. standard column-based algorithms. *J Hosp Med* 2010; 5:432–437
  356. Dortch MJ, Mowery NT, Ozdas A, et al: A computerized insulin infusion titration protocol improves glucose control with less hypoglycemia compared to a manual titration protocol in a trauma intensive care unit. *JPEN J Parenter Enteral Nutr* 2008; 32:18–27
  357. Mauritz W, Sporn P, Schindler I, et al: [Acute renal failure in abdominal infection. Comparison of hemodialysis and continuous arteriovenous hemofiltration]. *Anasth Intensivther Notfallmed* 1986; 21:212–217
  358. Bartlett RH, Mault JR, Dechert RE, et al: Continuous arteriovenous hemofiltration: Improved survival in surgical acute renal failure? *Surgery* 1986; 100:400–408
  359. Kierdorf H: Continuous versus intermittent treatment: Clinical results in acute renal failure. *Contrib Nephrol* 1991; 93:1–12
  360. Bellomo R, Mansfield D, Rumble S, et al: Acute renal failure in critical illness. Conventional dialysis versus acute continuous hemodiafiltration. *ASAIO J* 1992; 38:M654–M657
  361. Bellomo R, Farmer M, Parkin G, et al: Severe acute renal failure: A comparison of acute continuous hemodiafiltration and conventional dialytic therapy. *Nephron* 1995; 71:59–64
  362. Kruczynski K, Irvine-Bird K, Toffelmire EB, et al: A comparison of continuous arteriovenous hemofiltration and intermittent hemodialysis in acute renal failure patients in the intensive care unit. *ASAIO J* 1993; 39:M778–M781
  363. van Bommel E, Bouvy ND, So KL, et al: Acute dialytic support for the critically ill: Intermittent hemodialysis versus continuous arteriovenous hemodiafiltration. *Am J Nephrol* 1995; 15:192–200
  364. Guérin C, Girard R, Selli JM, et al: Intermittent versus continuous renal replacement therapy for acute renal failure in intensive care units: Results from a multicenter prospective epidemiological survey. *Intensive Care Med* 2002; 28:1411–1418
  365. Kellum JA, Angus DC, Johnson JP, et al: Continuous versus intermittent renal replacement therapy: A meta-analysis. *Intensive Care Med* 2002; 28:29–37
  366. Tonelli M, Manns B, Feller-Kopman D: Acute renal failure in the intensive care unit: A systematic review of the impact of dialytic modality on mortality and renal recovery. *Am J Kidney Dis* 2002; 40:875–885
  367. Mehta RL, McDonald B, Gabbai FB, et al; Collaborative Group for Treatment of ARF in the ICU: A randomized clinical trial of continuous versus intermittent dialysis for acute renal failure. *Kidney Int* 2001; 60:1154–1163
  368. Gasparovic V, Filipovic-Grcic I, Merkler M, et al: Continuous renal replacement therapy (CRRT) or intermittent hemodialysis (IHD)—what is the procedure of choice in critically ill patients? *Ren Fail* 2003; 25:855–862
  369. Augustine JJ, Sandy D, Seifert TH, et al: A randomized controlled trial comparing intermittent with continuous dialysis in patients with ARF. *Am J Kidney Dis* 2004; 44:1000–1007
  370. Uehlinger DE, Jakob SM, Ferrari P, et al: Comparison of continuous and intermittent renal replacement therapy for acute renal failure. *Nephrol Dial Transplant* 2005; 20:1630–1637
  371. Vinsonneau C, Camus C, Combes A, et al; Hemodiafe Study Group: Continuous venovenous haemodiafiltration versus intermittent haemodialysis for acute renal failure in patients with multiple-organ dysfunction syndrome: A multicentre randomised trial. *Lancet* 2006; 368:379–385



372. John S, Griesbach D, Baumgärtel M, et al: Effects of continuous haemofiltration vs intermittent haemodialysis on systemic haemodynamics and splanchnic regional perfusion in septic shock patients: A prospective, randomized clinical trial. *Nephrol Dial Transplant* 2001; 16:320–327
373. Misset B, Timsit JF, Chevret S, et al: A randomized cross-over comparison of the hemodynamic response to intermittent hemodialysis and continuous hemofiltration in ICU patients with acute renal failure. *Intensive Care Med* 1996; 22:742–746
374. Ronco C, Bellomo R, Homel P, et al: Effects of different doses in continuous veno-venous haemofiltration on outcomes of acute renal failure: A prospective randomised trial. *Lancet* 2000; 356:26–30
375. Bouman CS, Oudemans-Van Straaten HM, Tijssen JG, et al: Effects of early high-volume continuous venovenous hemofiltration on survival and recovery of renal function in intensive care patients with acute renal failure: A prospective, randomized trial. *Crit Care Med* 2002; 30:2205–2211
376. The VA/NIH Acute Renal Failure Trial Network: Intensity of renal support in critically ill patients with acute kidney injury. *N Engl J Med* 2008; 359:7–20
377. The RENAL Replacement Therapy Study Investigators: Intensity of continuous renal-replacement therapy in critically ill patients. *N Engl J Med* 2009; 361:1627–1638
378. Cooper DJ, Walley KR, Wiggs BR, et al: Bicarbonate does not improve hemodynamics in critically ill patients who have lactic acidosis. A prospective, controlled clinical study. *Ann Intern Med* 1990; 112:492–498
379. Mathieu D, Neviere R, Billard V, et al: Effects of bicarbonate therapy on hemodynamics and tissue oxygenation in patients with lactic acidosis: A prospective, controlled clinical study. *Crit Care Med* 1991; 19:1352–1356
380. Cade JF: High risk of the critically ill for venous thromboembolism. *Crit Care Med* 1982; 10:448–450
381. Halkin H, Goldberg J, Modan M, et al: Reduction of mortality in general medical in-patients by low-dose heparin prophylaxis. *Ann Intern Med* 1982; 96:561–565
382. Pingleton SK, Bone RC, Pingleton WW, et al: Prevention of pulmonary emboli in a respiratory intensive care unit: Efficacy of low-dose heparin. *Chest* 1981; 79:647–650
383. Belch JJ, Lowe GD, Ward AG, et al: Prevention of deep vein thrombosis in medical patients by low-dose heparin. *Scott Med J* 1981; 26:115–117
384. Gärdlund B: Randomised, controlled trial of low-dose heparin for prevention of fatal pulmonary embolism in patients with infectious diseases. The Heparin Prophylaxis Study Group. *Lancet* 1996; 347:1357–1361
385. Samama MM, Cohen AT, Darmon JY, et al: A comparison of enoxaparin with placebo for the prevention of venous thromboembolism in acutely ill medical patients. Prophylaxis in Medical Patients with Enoxaparin Study Group. *N Engl J Med* 1999; 341:793–800
386. Dahan R, Houlbert D, Caulin C, et al: Prevention of deep vein thrombosis in elderly medical in-patients by a low molecular weight heparin: A randomized double-blind trial. *Haemostasis* 1986; 16:159–164
387. Hirsch DR, Ingenito EP, Goldhaber SZ: Prevalence of deep venous thrombosis among patients in medical intensive care. *JAMA* 1995; 274:335–337
388. Fraisse F, Holzapfel L, Couland JM, et al: Nadroparin in the prevention of deep vein thrombosis in acute decompensated COPD. The Association of Non-University Affiliated Intensive Care Specialist Physicians of France. *Am J Respir Crit Care Med* 2000; 161(4 Pt 1):1109–1114
389. Kupfer Y, Anwar J, Seneviratne C, et al: Prophylaxis with subcutaneous heparin significantly reduces the incidence of deep venous thrombophlebitis in the critically ill. Abstr. *Am J Crit Care Med* 1999; 159(Suppl):A519
390. Geerts W, Cook D, Selby R, et al: Venous thromboembolism and its prevention in critical care. *J Crit Care* 2002; 17:95–104
391. Attia J, Ray JG, Cook DJ, et al: Deep vein thrombosis and its prevention in critically ill adults. *Arch Intern Med* 2001; 161:1268–1279
392. PROTECT Investigators for the Canadian Critical Care Trials Group and the Australian and New Zealand Intensive Care Society Clinical Trials Group, Cook D, Meade M, Guyatt G, et al: Dalteparin versus unfractionated heparin in critically ill patients. *New Engl J Med* 2011; 364:1305–1314
393. King CS, Holley AB, Jackson JL, et al: Twice vs three times daily heparin dosing for thromboembolism prophylaxis in the general medical population: A metaanalysis. *Chest* 2007; 131:507–516
394. Douketis J, Cook D, Meade M, et al; Canadian Critical Care Trials Group: Prophylaxis against deep vein thrombosis in critically ill patients with severe renal insufficiency with the low-molecular-weight heparin dalteparin: An assessment of safety and pharmacodynamics: The DIRECT study. *Arch Intern Med* 2008; 168:1805–1812
395. Vanek VW: Meta-analysis of effectiveness of intermittent pneumatic compression devices with a comparison of thigh-high to knee-high sleeves. *Am Surg* 1998; 64:1050–1058
396. Turpie AG, Hirsh J, Gent M, et al: Prevention of deep vein thrombosis in potential neurosurgical patients. A randomized trial comparing graduated compression stockings alone or graduated compression stockings plus intermittent pneumatic compression with control. *Arch Intern Med* 1989; 149:679–681
397. Agu O, Hamilton G, Baker D: Graduated compression stockings in the prevention of venous thromboembolism. *Br J Surg* 1999; 86:992–1004
398. Kakkos SK, Caprini JA, Geroulakos G, et al: Combined intermittent pneumatic leg compression and pharmacological prophylaxis for prevention of venous thromboembolism in high-risk patients. *Cochrane Database Syst Rev* 2008; 4: CD005258
399. German Hip Arthroplasty Trial Group (GHAT): Prevention of deep vein thrombosis with low molecular-weight heparin in patients undergoing total hip replacement: A randomized trial. *Arch Orthop Trauma Surg* 1992; 111:110–120
400. Colwell CW Jr, Spiro TE, Trowbridge AA, et al: Use of enoxaparin, a low-molecular-weight heparin, and unfractionated heparin for the prevention of deep venous thrombosis after elective hip replacement. A clinical trial comparing efficacy and safety. Enoxaparin Clinical Trial Group. *J Bone Joint Surg Am* 1994; 76:3–14
401. Geerts WH, Jay RM, Code KI, et al: A comparison of low-dose heparin with low-molecular-weight heparin as prophylaxis against venous thromboembolism after major trauma. *N Engl J Med* 1996; 335:701–707
402. Guyatt GH, Akl EA, Crowther M, et al: Executive summary: Antithrombotic therapy and prevention of thrombosis, 9th ed: American College of Chest Physicians Evidence-Based Clinical Practice Guidelines. *Chest* 2012; 141(Suppl 2):7S–47S
403. Basso N, Bagarani M, Materia A, et al: Cimetidine and antacid prophylaxis of acute upper gastrointestinal bleeding in high risk patients. Controlled, randomized trial. *Am J Surg* 1981; 141:339–341
404. Bresalier RS, Grendell JH, Cello JP, et al: Sucralfate suspension versus titrated antacid for the prevention of acute stress-related gastrointestinal hemorrhage in critically ill patients. *Am J Med* 1987; 83(3B):110–116
405. Poleski MH, Spanier AH: Cimetidine versus antacids in the prevention of stress erosions in critically ill patients. *Am J Gastroenterol* 1986; 81:107–111
406. Stothert JC Jr, Simonowitz DA, Dellinger EP, et al: Randomized prospective evaluation of cimetidine and antacid control of gastric pH in the critically ill. *Ann Surg* 1980; 192:169–174
407. Cook DJ, Fuller HD, Guyatt GH, et al: Risk factors for gastrointestinal bleeding in critically ill patients. Canadian Critical Care Trials Group. *N Engl J Med* 1994; 330:377–381
408. Schuster DP, Rowley H, Feinstein S, et al: Prospective evaluation of the risk of upper gastrointestinal bleeding after admission to a medical intensive care unit. *Am J Med* 1984; 76:623–630
409. Kahn JM, Doctor JN, Rubenfeld GD: Stress ulcer prophylaxis in mechanically ventilated patients: Integrating evidence and judgment using a decision analysis. *Intensive Care Med* 2006; 32:1151–1158
410. Cook DJ, Reeve BK, Guyatt GH, et al: Stress ulcer prophylaxis in critically ill patients. Resolving discordant meta-analyses. *JAMA* 1996; 275:308–314
411. Marik PE, Vasu T, Hirani A, et al: Stress ulcer prophylaxis in the new millennium: A systematic review and meta-analysis. *Crit Care Med* 2010; 38:2222–2228

412. Howell MD, Novack V, Grgurich P, et al: Iatrogenic gastric acid suppression and the risk of nosocomial *Clostridium difficile* infection. *Arch Intern Med* 2010; 170:784–790
413. Leonard J, Marshall JK, Moayyedi P: Systematic review of the risk of enteric infection in patients taking acid suppression. *Am J Gastroenterol* 2007; 102:2047–56; quiz 2057
414. Cook D, Guyatt G, Marshall J, et al: A comparison of sucralfate and ranitidine for the prevention of upper gastrointestinal bleeding in patients requiring mechanical ventilation. Canadian Critical Care Trials Group. *N Engl J Med* 1998; 338:791–797
415. Lin P, Chang C, Hsu P, et al: The efficacy and safety of proton pump inhibitors vs histamine-2 receptor antagonists for stress ulcer bleeding prophylaxis among critical care patients: A meta-analysis. *Crit Care Med* 2010; 38:1197–1205
416. Pongprasobchai S, Kridkratoke S, Nopmaneejumruslers C: Proton pump inhibitors for the prevention of stress-related mucosal disease in critically-ill patients: A meta-analysis. *J Med Assoc Thai* 2009; 92:632–637
417. Alhazzani W, Alshahrani M, Moayyedi P, et al: Stress ulcer prophylaxis in critically ill patients: Review of the evidence. *Pol Arch Med Wewn* 2012; 122:107–114
418. Moore EE, Jones TN: Benefits of immediate jejunostomy feeding after major abdominal trauma—A prospective, randomized study. *J Trauma* 1986; 26:874–881
419. Chiarelli A, Enzi G, Casadei A, et al: Very early nutrition supplementation in burned patients. *Am J Clin Nutr* 1990; 51:1035–1039
420. Eyer SD, Micon LT, Konstantinides FN, et al: Early enteral feeding does not attenuate metabolic response after blunt trauma. *J Trauma* 1993; 34:639–43; discussion 643
421. Chuntrasakul C, Siltharm S, Chinswangwatanakul V, et al: Early nutritional support in severe traumatic patients. *J Med Assoc Thai* 1996; 79:21–26
422. Singh G, Ram RP, Khanna SK: Early postoperative enteral feeding in patients with nontraumatic intestinal perforation and peritonitis. *J Am Coll Surg* 1998; 187:142–146
423. Kompan L, Kremzar B, Gadzijeve E, et al: Effects of early enteral nutrition on intestinal permeability and the development of multiple organ failure after multiple injury. *Intensive Care Med* 1999; 25:157–161
424. Minard G, Kudsk KA, Melton S, et al: Early versus delayed feeding with an immune-enhancing diet in patients with severe head injuries. *JPEN J Parenter Enteral Nutr* 2000; 24:145–149
425. Pupelis G, Selga G, Austrums E, et al: Jejunal feeding, even when instituted late, improves outcomes in patients with severe pancreatitis and peritonitis. *Nutrition* 2001; 17:91–94
426. Kompan L, Vidmar G, Spindler-Vesel A, et al: Is early enteral nutrition a risk factor for gastric intolerance and pneumonia? *Clin Nutr* 2004; 23:527–532
427. Nguyen NQ, Fraser RJ, Bryant LK, et al: The impact of delaying enteral feeding on gastric emptying, plasma cholecystokinin, and peptide YY concentrations in critically ill patients. *Crit Care Med* 2008; 36:1469–1474
428. Marik PE, Zaloga GP: Early enteral nutrition in acutely ill patients: A systematic review. *Crit Care Med* 2001; 29:2264–2270
429. Heyland DK, Dhaliwal R, Drover JW, et al; Canadian Critical Care Clinical Practice Guidelines Committee: Canadian clinical practice guidelines for nutrition support in mechanically ventilated, critically ill adult patients. *JPEN J Parenter Enteral Nutr* 2003; 27:355–373
430. Doig GS, Heighes PT, Simpson F, et al: Early enteral nutrition, provided within 24 h of injury or intensive care unit admission, significantly reduces mortality in critically ill patients: A meta-analysis of randomised controlled trials. *Intensive Care Med* 2009; 35:2018–2027
431. Taylor SJ, Fettes SB, Jewkes C, et al: Prospective, randomized, controlled trial to determine the effect of early enhanced enteral nutrition on clinical outcome in mechanically ventilated patients suffering head injury. *Crit Care Med* 1999; 27:2525–2531
432. Ibrahim EH, Mehlinger L, Prentice D, et al: Early versus late enteral feeding of mechanically ventilated patients: Results of a clinical trial. *JPEN J Parenter Enteral Nutr* 2002; 26:174–181
433. Rice TW, Mogan S, Hays MA, et al: Randomized trial of initial trophic versus full-energy enteral nutrition in mechanically ventilated patients with acute respiratory failure. *Crit Care Med* 2011; 39:967–974
434. National Heart, Lung, and Blood Institute Acute Respiratory Distress Syndrome (ARDS) Clinical Trials Network, Rice TW, Wheeler AP, Thompson BT, et al: Trophic vs full enteral feeding in patients with acute lung injury: The EDEN randomized trial. *JAMA* 2012; 137:795–803
435. Arabi YM, Tamim HM, Dhar GS, et al: Permissive underfeeding and intensive insulin therapy in critically ill patients: A randomized controlled trial. *Am J Clin Nutr* 2011; 93:569–577
436. Cerra FB, McPherson JP, Konstantinides FN, et al: Enteral nutrition does not prevent multiple organ failure syndrome (MOFS) after sepsis. *Surgery* 1988; 104:727–733
437. Heyland DK, MacDonald S, Keefe L, et al: Total parenteral nutrition in the critically ill patient: A meta-analysis. *JAMA* 1998; 280:2013–2019
438. Braunschweig CL, Levy P, Sheean PM, et al: Enteral compared with parenteral nutrition: A meta-analysis. *Am J Clin Nutr* 2001; 74:534–542
439. Gramlich L, Kichian K, Pinilla J, et al: Does enteral nutrition compared to parenteral nutrition result in better outcomes in critically ill adult patients? A systematic review of the literature. *Nutrition* 2004; 20:843–848
440. Dhaliwal R, Jurewitsch B, Harrietha D, et al: Combination enteral and parenteral nutrition in critically ill patients: Harmful or beneficial? A systematic review of the evidence. *Intensive Care Med* 2004; 30:1666–1671
441. Peter JV, Moran JL, Phillips-Hughes J: A metaanalysis of treatment outcomes of early enteral versus early parenteral nutrition in hospitalized patients. *Crit Care Med* 2005; 33:213–220; discussion 260
442. Simpson F, Doig GS: Parenteral vs. enteral nutrition in the critically ill patient: A meta-analysis of trials using the intention to treat principle. *Intensive Care Med* 2005; 31:12–23
443. Koretz RL, Avenell A, Lipman TO, et al: Does enteral nutrition affect clinical outcome? A systematic review of the randomized trials. *Am J Gastroenterol* 2007; 102:412–429; quiz 468
444. Casaer MP, Mesotten D, Hermans G, et al: Early versus late parenteral nutrition in critically ill adults. *N Engl J Med* 2011; 365:506–517
445. Beale RJ, Bryg DJ, Bihari DJ: Immunonutrition in the critically ill: A systematic review of clinical outcome. *Crit Care Med* 1999; 27:2799–2805
446. Heyland DK, Novak F, Drover JW, et al: Should immunonutrition become routine in critically ill patients? A systematic review of the evidence. *JAMA* 2001; 286:944–953
447. Montejo JC, Zarazaga A, López-Martínez J, et al; Spanish Society of Intensive Care Medicine and Coronary Units: Immunonutrition in the intensive care unit. A systematic review and consensus statement. *Clin Nutr* 2003; 22:221–233
448. Marik PE, Zaloga GP: Immunonutrition in critically ill patients: A systematic review and analysis of the literature. *Intensive Care Med* 2008; 34:1980–1990
449. Kieft H, Roos AN, van Drunen JD, et al: Clinical outcome of immunonutrition in a heterogeneous intensive care population. *Intensive Care Med* 2005; 31:524–532
450. Tugrul S, Ozcan PE, Akinci IO, et al: [The effects of immunonutrition on the development of nosocomial infections and on clinical outcome in critically ill patients]. *Ulus Travma Acil Cerrahi Derg* 2004; 10:89–96
451. Radrizzani D, Bertolini G, Facchini R, et al: Early enteral immunonutrition vs. parenteral nutrition in critically ill patients without severe sepsis: A randomized clinical trial. *Intensive Care Med* 2006; 32:1191–1198
452. Bertolini G, Iapichino G, Radrizzani D, et al: Early enteral immunonutrition in patients with severe sepsis: Results of an interim analysis of a randomized multicentre clinical trial. *Intensive Care Med* 2003; 29:834–840
453. Suchner U, Kuhn KS, Fürst P: The scientific basis of immunonutrition. *Proc Nutr Soc* 2000; 59:553–563

454. Santora R, Kozar RA: Molecular mechanisms of pharmaconutrients. *J Surg Res* 2010; 161:288–294
455. Bower RH, Cerra FB, Bershadsky B, et al: Early enteral administration of a formula (Impact) supplemented with arginine, nucleotides, and fish oil in intensive care unit patients: Results of a multicenter, prospective, randomized, clinical trial. *Crit Care Med* 1995; 23:436–449
456. Galbán C, Montejo JC, Mesejo A, et al: An immune-enhancing enteral diet reduces mortality rate and episodes of bacteremia in septic intensive care unit patients. *Crit Care Med* 2000; 28:643–648
457. Caparrós T, Lopez J, Grau T: Early enteral nutrition in critically ill patients with a high-protein diet enriched with arginine, fiber, and antioxidants compared with a standard high-protein diet. The effect on nosocomial infections and outcome. *JPEN J Parenter Enteral Nutr* 2001; 25:299–308; discussion 308
458. Preiser JC, Berré PJ, Van Gossum A, et al: Metabolic effects of arginine addition to the enteral feeding of critically ill patients. *JPEN J Parenter Enteral Nutr* 2001; 25:182–187
459. Novak F, Heyland DK, Avenell A, et al: Glutamine supplementation in serious illness: A systematic review of the evidence. *Crit Care Med* 2002; 30:2022–2029
460. Avenell A: Glutamine in critical care: Current evidence from systematic reviews. *Proc Nutr Soc* 2006; 65:236–241
461. Jiang H, Chen W, Hu W, et al: [The impact of glutamine-enhanced enteral nutrition on clinical outcome of patients with critical illness: A systematic review of randomized controlled trials]. *Zhonghua Shao Shang Za Zhi* 2009; 25:325–330
462. Avenell A: Hot topics in parenteral nutrition. Current evidence and ongoing trials on the use of glutamine in critically-ill patients and patients undergoing surgery. *Proc Nutr Soc* 2009; 68:261–268
463. Tian H, Wang KF, Wu TJ: [Effect of total parenteral nutrition with supplementation of glutamine on the plasma diamine oxidase activity and D-lactate content in patients with multiple organ dysfunction syndrome]. *Zhongguo Wei Zhong Bing Ji Jiu Yi Xue* 2006; 18:616–618
464. Cai GL, Yan J, Yu YH, et al: [Influence of glutamine and growth hormone intensified nutrition support on immunomodulation in critically ill elderly patients]. *Zhongguo Wei Zhong Bing Ji Jiu Yi Xue* 2006; 18:595–598
465. Grau T, Bonet A, Miñambres E, et al; Metabolism, Nutrition Working Group, SEMICYUC, Spain: The effect of L-alanyl-L-glutamine dipeptide supplemented total parenteral nutrition on infectious morbidity and insulin sensitivity in critically ill patients. *Crit Care Med* 2011; 39:1263–1268
466. Wernerman J, Kirketeig T, Andersson B, et al; Scandinavian Critical Care Trials Group: Scandinavian glutamine trial: A pragmatic multicentre randomised clinical trial of intensive care unit patients. *Acta Anaesthesiol Scand* 2011; 55:812–818
467. Fuentes-Orozco C, Anaya-Prado R, González-Ojeda A, et al: L-alanyl-L-glutamine-supplemented parenteral nutrition improves infectious morbidity in secondary peritonitis. *Clin Nutr* 2004; 23:13–21
468. Beale RJ, Sherry T, Lei K, et al: Early enteral supplementation with key pharmaconutrients improves Sequential Organ Failure Assessment score in critically ill patients with sepsis: Outcome of a randomized, controlled, double-blind trial. *Crit Care Med* 2008; 36:131–144
469. Trial of glutamine and antioxidant supplementation in critically ill patients (REDOXS). <http://clinicaltrials.gov/ct2/show/NCT00133978?term=NCT00133978&rank=1>
470. Pontes-Arruda A, Demichele S, Seth A, et al: The use of an inflammation-modulating diet in patients with acute lung injury or acute respiratory distress syndrome: A meta-analysis of outcome data. *JPEN J Parenter Enteral Nutr* 2008; 32:596–605
471. Pontes-Arruda A, Aragão AM, Albuquerque JD: Effects of enteral feeding with eicosapentaenoic acid, gamma-linolenic acid, and antioxidants in mechanically ventilated patients with severe sepsis and septic shock. *Crit Care Med* 2006; 34:2325–2333
472. Gadek JE, DeMichele SJ, Karlstad MD, et al: Effect of enteral feeding with eicosapentaenoic acid, gamma-linolenic acid, and antioxidants in patients with acute respiratory distress syndrome. Enteral Nutrition in ARDS Study Group. *Crit Care Med* 1999; 27:1409–1420
473. Singer P, Theilla M, Fisher H, et al: Benefit of an enteral diet enriched with eicosapentaenoic acid and gamma-linolenic acid in ventilated patients with acute lung injury. *Crit Care Med* 2006; 34:1033–1038
474. Pontes-Arruda A, Martins LF, de Lima SM, et al; Investigating Nutritional Therapy with EPA, GLA and Antioxidants Role in Sepsis Treatment (INTERSEPT) Study Group: Enteral nutrition with eicosapentaenoic acid,  $\gamma$ -linolenic acid and antioxidants in the early treatment of sepsis: Results from a multicenter, prospective, randomized, double-blinded, controlled study: The INTERSEPT study. *Crit Care* 2011; 15:R144
475. Rice TW, Wheeler AP, Thompson BT, et al; NIH NHLBI Acute Respiratory Distress Syndrome Network of Investigators; NHLBI ARDS Clinical Trials Network: Enteral omega-3 fatty acid, gamma-linolenic acid, and antioxidant supplementation in acute lung injury. *JAMA* 2011; 306:1574–1581
476. Stapleton RD, Martin TR, Weiss NS, et al: A phase II randomized placebo-controlled trial of omega-3 fatty acids for the treatment of acute lung injury. *Crit Care Med* 2011; 39:1655–1662
477. Grau-Carmona T, Morán-García V, García-de-Lorenzo A, et al: Effect of an enteral diet enriched with eicosapentaenoic acid, gamma-linolenic acid and anti-oxidants on the outcome of mechanically ventilated, critically ill, septic patients. *Clin Nutr* 2011; 30:578–584
478. Friesecke S, Lotze C, Köhler J, et al: Fish oil supplementation in the parenteral nutrition of critically ill medical patients: A randomised controlled trial. *Intensive Care Med* 2008; 34:1411–1420
479. Barbosa VM, Miles EA, Calhau C, et al: Effects of a fish oil containing lipid emulsion on plasma phospholipid fatty acids, inflammatory markers, and clinical outcomes in septic patients: A randomized, controlled clinical trial. *Crit Care* 2010; 14:R5
480. Gupta A, Govil D, Bhatnagar S, et al: Efficacy and safety of parenteral omega 3 fatty acids in ventilated patients with acute lung injury. *Indian J Crit Care Med* 2011; 15:108–113
481. Thompson BT, Cox PN, Antonelli M, et al; American Thoracic Society; European Respiratory Society; European Society of Intensive Care Medicine; Society of Critical Care Medicine; Société de Réanimation de Langue Française: *Challenges in end-of-life care in the ICU: statement of the 5th International Consensus Conference in Critical Care*: Brussels, Belgium, April 2003: executive summary. *Crit Care Med* 2004; 32:1781–1784
482. Sprung CL, Cohen SL, Sjøkvist P, et al; Ethicus Study Group: End-of-life practices in European intensive care units: The Ethicus Study. *JAMA* 2003; 290:790–797
483. White DB, Engelberg RA, Wenrich MD, et al: The language of prognostication in intensive care units. *Med Decis Making* 2010; 30:76–83
484. Nelson JE, Bassett R, Boss RD, et al; Improve Palliative Care in the Intensive Care Unit Project: Models for structuring a clinical initiative to enhance palliative care in the intensive care unit: A report from the IPAL-ICU Project (Improving Palliative Care in the ICU). *Crit Care Med* 2010; 38:1765–1772
485. Evans LR, Boyd EA, Malvar G, et al: Surrogate decision-makers' perspectives on discussing prognosis in the face of uncertainty. *Am J Respir Crit Care Med* 2009; 179:48–53
486. Lee Char SJ, Evans LR, Malvar GL, et al: A randomized trial of two methods to disclose prognosis to surrogate decision makers in intensive care units. *Am J Respir Crit Care Med* 2010; 182:905–909
487. Azoulay E, Metnitz B, Sprung CL, et al; SAPS 3 investigators: End-of-life practices in 282 intensive care units: Data from the SAPS 3 database. *Intensive Care Med* 2009; 35:623–630
488. Azoulay E, Timsit JF, Sprung CL, et al; Conflicus Study Investigators and for the Ethics Section of the European Society of Intensive Care Medicine: Prevalence and factors of intensive care unit conflicts: The conflicus study. *Am J Respir Crit Care Med* 2009; 180:853–860
489. Bertolini G, Boffelli S, Malacarne P, et al: End-of-life decision-making and quality of ICU performance: An observational study in 84 Italian units. *Intensive Care Med* 2010; 36:1495–1504
490. Detering KM, Hancock AD, Reade MC, et al: The impact of advance care planning on end of life care in elderly patients: Randomised controlled trial. *BMJ* 2010; 340:c1345



491. Machare Delgado E, Callahan A, Paganelli G, et al: Multidisciplinary family meetings in the ICU facilitate end-of-life decision making. *Am J Hosp Palliat Care* 2009; 26:295–302
492. Lautrette A, Darmon M, Megarbane B, et al: A communication strategy and brochure for relatives of patients dying in the ICU. *N Engl J Med* 2007; 356:469–478
493. Norton SA, Hogan LA, Holloway RG, et al: Proactive palliative care in the medical intensive care unit: Effects on length of stay for selected high-risk patients. *Crit Care Med* 2007; 35:1530–1535
494. Scheunemann LP, McDevitt M, Carson SS, et al: Randomized, controlled trials of interventions to improve communication in intensive care: A systematic review. *Chest* 2011; 139:543–554
495. Davidson JE, Powers K, Hedayat KM, et al: American College of Critical Care Medicine Task Force 2004-2005, Society of Critical Care Medicine: Clinical practice guidelines for support of the family in the patient-centered intensive care unit: American College of Critical Care Medicine Task Force 2004-2005. *Crit Care Med* 2007; 35:605–622
496. Curtis JR, Treece PD, Nielsen EL, et al: Integrating palliative and critical care: Evaluation of a quality-improvement intervention. *Am J Respir Crit Care Med* 2008; 178:269–275
497. Odetola FO, Gebremariam A, Freed GL: Patient and hospital correlates of clinical outcomes and resource utilization in severe pediatric sepsis. *Pediatrics* 2007; 119:487–494
498. Typpo KV, Petersen NJ, Hallman DM, et al: Day 1 multiple organ dysfunction syndrome is associated with poor functional outcome and mortality in the pediatric intensive care unit. *Pediatr Crit Care Med* 2009; 10:562–570
499. Kisson N, Carcillo JA, Espinosa V, et al: Global Sepsis Initiative Vanguard Center Contributors: World Federation of Pediatric Intensive Care and Critical Care Societies: Global Sepsis Initiative. *Pediatr Crit Care Med* 2011; 12:494–503
500. Goldstein B, Giroir B, Randolph A; International Consensus Conference on Pediatric Sepsis: International pediatric sepsis consensus conference: Definitions for sepsis and organ dysfunction in pediatrics. *Pediatr Crit Care Med* 2005; 6:2–8
501. Kuch BA, Carcillo JA, Han YY, et al: Definitions of pediatric septic shock. *Pediatr Crit Care Med* 2005; 6:501; author reply 501
502. Cam BV, Tuan DT, Fonsmark L, et al: Randomized comparison of oxygen mask treatment vs. nasal continuous positive airway pressure in dengue shock syndrome with acute respiratory failure. *J Trop Pediatr* 2002; 48:335–339
503. Duke T, Mgone J, Frank D: Hypoxaemia in children with severe pneumonia in Papua New Guinea. *Int J Tuberc Lung Dis* 2001; 5:511–519
504. Pollard AJ, Britto J, Nadel S, et al: Emergency management of meningococcal disease. *Arch Dis Child* 1999; 80:290–296
505. den Brinker M, Joosten KF, Liem O, et al: Adrenal insufficiency in meningococcal sepsis: Bioavailable cortisol levels and impact of interleukin-6 levels and intubation with etomidate on adrenal function and mortality. *J Clin Endocrinol Metab* 2005; 90:5110–5117
506. Han YY, Carcillo JA, Dragotta MA, et al: Early reversal of pediatric-neonatal septic shock by community physicians is associated with improved outcome. *Pediatrics* 2003; 112:793–799
507. Carcillo JA, Kuch BA, Han YY, et al: Mortality and functional morbidity after use of PALS/APLS by community physicians. *Pediatrics* 2009; 124:500–508
508. Oliveira CF, Nogueira de Sá FR, Oliveira DS, et al: Time- and fluid-sensitive resuscitation for hemodynamic support of children in septic shock: Barriers to the implementation of the American College of Critical Care Medicine/Pediatric Advanced Life Support Guidelines in a pediatric intensive care unit in a developing world. *Pediatr Emerg Care* 2008; 24:810–815
509. Raimer PL, Han YY, Weber MS, et al: A normal capillary refill time of = 2 seconds is associated with superior vena cava oxygen saturations of = 70%. *J Pediatr* 2011; 158:968–972
510. Brierley J, Carcillo JA, Choong K, et al: Clinical practice parameters for hemodynamic support of pediatric and neonatal septic shock: 2007 update from the American College of Critical Care Medicine. *Crit Care Med* 2009; 37:666–688
511. de Oliveira CF, de Oliveira DS, Gottschald AF, et al: ACCM/PALS haemodynamic support guidelines for paediatric septic shock: An outcomes comparison with and without monitoring central venous oxygen saturation. *Intensive Care Med* 2008; 34:1065–1075
512. Inwald DP, Tasker RC, Peters MJ, et al; Paediatric Intensive Care Society Study Group (PICS-SG): Emergency management of children with severe sepsis in the United Kingdom: The results of the Paediatric Intensive Care Society sepsis audit. *Arch Dis Child* 2009; 94:348–353
513. Malbrain ML, De laet I, Cheatham M: Consensus conference definitions and recommendations on intra-abdominal hypertension (IAH) and the abdominal compartment syndrome (ACS)—the long road to the final publications, how did we get there? *Acta Clin Belg Suppl* 2007; Suppl:44–59
514. Cheatham ML, Malbrain ML, Kirkpatrick A, et al: Results from the International Conference of Experts on Intra-abdominal Hypertension and Abdominal Compartment Syndrome. II. Recommendations. *Intensive Care Med* 2007; 33:951–962
515. Pearson EG, Rollins MD, Vogler SA, et al: Decompressive laparotomy for abdominal compartment syndrome in children: Before it is too late. *J Pediatr Surg* 2010; 45:1324–1329
516. Amado VM, Vilela GP, Queiroz A Jr, et al: Effect of a quality improvement intervention to decrease delays in antibiotic delivery in pediatric febrile neutropenia: A pilot study. *J Crit Care* 2011; 26:103.e9–103.12
517. Cordery RJ, Roberts CH, Cooper SJ, et al: Evaluation of risk factors for the acquisition of bloodstream infections with extended-spectrum beta-lactamase-producing *Escherichia coli* and *Klebsiella* species in the intensive care unit; antibiotic management and clinical outcome. *J Hosp Infect* 2008; 68:108–115
518. Ardura MI, Mejias A, Katz KS, et al: Daptomycin therapy for invasive Gram-positive bacterial infections in children. *Pediatr Infect Dis J* 2007; 26:1128–1132
519. Corey AL, Snyder S: Antibiotics in 30 minutes or less for febrile neutropenic patients: A quality control measure in a new hospital. *J Pediatr Oncol Nurs* 2008; 25:208–212
520. Russell NE, Pachorek RE: Clindamycin in the treatment of streptococcal and staphylococcal toxic shock syndromes. *Ann Pharmacother* 2000; 34:936–939
521. Nathwani D, Morgan M, Masterton RG, et al; British Society for Antimicrobial Chemotherapy Working Party on Community-onset MRSA Infections: Guidelines for UK practice for the diagnosis and management of methicillin-resistant *Staphylococcus aureus* (MRSA) infections presenting in the community. *J Antimicrob Chemother* 2008; 61:976–994
522. Gemmell CG, Edwards DI, Fraise AP, et al; Joint Working Party of the British Society for Joint Working Party of the British Society for Antimicrobial Chemotherapy, Hospital Infection Society and Infection Control Nurses Association: Guidelines for the prophylaxis and treatment of methicillin-resistant *Staphylococcus aureus* (MRSA) infections in the UK. *J Antimicrob Chemother* 2006; 57:589–608
523. Cawley MJ, Briggs M, Haith LR Jr, et al: Intravenous immunoglobulin as adjunctive treatment for streptococcal toxic shock syndrome associated with necrotizing fasciitis: Case report and review. *Pharmacotherapy* 1999; 19:1094–1098
524. Rodríguez-Núñez A, Dosil-Gallardo S, Jordan I; ad hoc Streptococcal Toxic Shock Syndrome collaborative group of Spanish Society of Pediatric Intensive Care: Clinical characteristics of children with group A streptococcal toxic shock syndrome admitted to pediatric intensive care units. *Eur J Pediatr* 2011; 170:639–644
525. Paganini HR, Della Latta P, Soto A, et al: [Community-acquired *Staphylococcus aureus* bacteremia: 17 years of experience in Argentine children]. *Arch Argent Pediatr* 2010; 108:311–317
526. Tilanus AM, de Geus HR, Rijnders BJ, et al: Severe group A streptococcal toxic shock syndrome presenting as primary peritonitis: A case report and brief review of the literature. *Int J Infect Dis* 2010; 14 Suppl 3:e208–e212
527. Newland JG, Kearns GL: Treatment strategies for methicillin-resistant *Staphylococcus aureus* infections in pediatrics. *Paediatr Drugs* 2008; 10:367–378

528. Barie PS, Williams MD, McCollam JS, et al; PROWESS Surgical Evaluation Committee: Benefit/risk profile of drotrecogin alfa (activated) in surgical patients with severe sepsis. *Am J Surg* 2004; 188:212–220
529. Barie PS, Hydo LJ, Shou J, et al: Efficacy and safety of drotrecogin alfa (activated) for the therapy of surgical patients with severe sepsis. *Surg Infect (Larchmt)* 2006; 7 Suppl 2:S77–S80
530. Marshall JC, Maier RV, Jimenez M, et al: Source control in the management of severe sepsis and septic shock: An evidence-based review. *Crit Care Med* 2004; 32(11 Suppl):S513–S526
531. Penington AJ, Craft RO, Tilkorn DJ: Plastic surgery management of soft tissue loss in meningococcal septicemia: Experience of the Melbourne Royal Children's Hospital. *Ann Plast Surg* 2007; 58:308–314
532. Wheeler JS, Anderson BJ, De Chalain TM: Surgical interventions in children with meningococcal purpura fulminans—A review of 117 procedures in 21 children. *J Pediatr Surg* 2003; 38:597–603
533. Jackson MA, Colombo J, Boldrey A: Streptococcal fasciitis with toxic shock syndrome in the pediatric patient. *Orthop Nurs* 2003; 22:4–8
534. Xiao-Wu W, Herndon DN, Spies M, et al: Effects of delayed wound excision and grafting in severely burned children. *Arch Surg* 2002; 137:1049–1054
535. Haecker FM, Berger D, Schumacher U, et al: Peritonitis in childhood: Aspects of pathogenesis and therapy. *Pediatr Surg Int* 2000; 16:182–188
536. Gwynne-Jones DP, Stott NS: Community-acquired methicillin-resistant *Staphylococcus aureus*: A cause of musculoskeletal sepsis in children. *J Pediatr Orthop* 1999; 19:413–416
537. Wu MH, Tseng YL, Lin MY, et al: Surgical treatment of pediatric lung abscess. *Pediatr Surg Int* 1997; 12:293–295
538. Murphy JJ, Granger R, Blair GK, et al: Necrotizing fasciitis in childhood. *J Pediatr Surg* 1995; 30:1131–1134
539. Jaber MR, Olafsson S, Fung WL, et al: Clinical review of the management of fulminant *Clostridium difficile* infection. *Am J Gastroenterol* 2008; 103:3195–203; quiz 3204
540. Ananthakrishnan AN: *Clostridium difficile* infection: Epidemiology, risk factors and management. *Nat Rev Gastroenterol Hepatol* 2011; 8:17–26
541. Olivas AD, Umanskiy K, Zuckerbraun B, et al: Avoiding colectomy during surgical management of fulminant *Clostridium difficile* colitis. *Surg Infect (Larchmt)* 2010; 11:299–305
542. Ngo NT, Cao XT, Kneen R, et al: Acute management of dengue shock syndrome: A randomized double-blind comparison of 4 intravenous fluid regimens in the first hour. *Clin Infect Dis* 2001; 32:204–213
543. Willis BA, Dung NM, Loan HT, et al: Comparison of three fluid solutions for resuscitation in dengue shock syndrome. *N Engl J Med* 2005; 353:877–889
544. Dung NM, Day NP, Tam DT, et al: Fluid replacement in dengue shock syndrome: A randomized, double-blind comparison of four intravenous-fluid regimens. *Clin Infect Dis* 1999; 29:787–794
545. Booy R, Habibi P, Nadel S, et al; Meningococcal Research Group: Reduction in case fatality rate from meningococcal disease associated with improved healthcare delivery. *Arch Dis Child* 2001; 85:386–390
546. Maat M, Buysse CM, Emonts M, et al: Improved survival of children with sepsis and purpura: Effects of age, gender, and era. *Crit Care* 2007; 11:R112
547. Cruz AT, Perry AM, Williams EA, et al: Implementation of goal-directed therapy for children with suspected sepsis in the emergency department. *Pediatrics* 2011; 127:e758–e766
548. Kanter RK, Zimmerman JJ, Strauss RH, et al: Pediatric emergency intravenous access. Evaluation of a protocol. *Am J Dis Child* 1986; 140:132–134
549. Carcillo JA, Davis AL, Zaritsky A: Role of early fluid resuscitation in pediatric septic shock. *JAMA* 1991; 266:1242–1245
550. Ranjit S, Kissoon N, Jayakumar I: Aggressive management of dengue shock syndrome may decrease mortality rate: a suggested protocol. *Pediatr Crit Care Med* 2005; 6:412–419
551. Akech S, Ledermann H, Maitland K: Choice of fluids for resuscitation in children with severe infection and shock: systematic review. *BMJ* 2010; 341:c4416
552. Santhanam I, Sangareddi S, Venkataraman S, et al: A prospective randomized controlled study of two fluid regimens in the initial management of septic shock in the emergency department. *Pediatr Emerg Care* 2008; 24:647–655
553. Ninis N, Phillips C, Bailey L, et al: The role of healthcare delivery in the outcome of meningococcal disease in children: case-control study of fatal and non-fatal cases. *BMJ* 2005; 330:1475
554. Thompson MJ, Ninis N, Perera R, et al: Clinical recognition of meningococcal disease in children and adolescents. *Lancet* 2006; 367:397–403
555. Ceneviva G, Paschall JA, Maffei F, et al: Hemodynamic support in fluid-refractory pediatric septic shock. *Pediatrics* 1998; 102:e19
556. Choong K, Bohn D, Fraser DD, et al: Vasopressin in pediatric vasodilatory shock: a multicenter randomized controlled trial. *Am J Respir Crit Care Med* 2009; 180:632–639
557. Yildizdas D, Yapicioglu H, Celik U, et al: Terlipressin as a rescue therapy for catecholamine-resistant septic shock in children. *Intensive Care Med* 2008; 34:511–517
558. Rodríguez-Núñez A, López-Herce J, Gil-Antón J, et al: Rescue treatment with terlipressin in children with refractory septic shock: a clinical study. *Crit Care* 2006; 10:R20
559. Rodríguez-Núñez A, Oulego-Eroz I, Gil-Antón J, et al: Continuous terlipressin infusion as rescue treatment in a case series of children with refractory septic shock. *Ann Pharmacother* 2010; 44:1545–1553
560. Keeley SR, Bohn DJ: The use of inotropic and afterload-reducing agents in neonates. *Clin Perinatol* 1988; 15:467–489
561. Barton P, Garcia J, Kouatli A, et al: Hemodynamic effects of i.v. milrinone lactate in pediatric patients with septic shock. A prospective, double-blinded, randomized, placebo-controlled, interventional study. *Chest* 1996; 109:1302–1312
562. Lindsay CA, Barton P, Lawless S, et al: Pharmacokinetics and pharmacodynamics of milrinone lactate in pediatric patients with septic shock. *J Pediatr* 1998; 132:329–334
563. Irazusta JE, Pretzlaff RK, Rowin ME: Amrinone in pediatric refractory septic shock: An open-label pharmacodynamic study. *Pediatr Crit Care Med* 2001; 2:24–28
564. Powell KR, Sugarman LI, Eskenazi AE, et al: Normalization of plasma arginine vasopressin concentrations when children with meningitis are given maintenance plus replacement fluid therapy. *J Pediatr* 1990; 117:515–522
565. Ringe HI, Varnholt V, Gaedicke G: Cardiac rescue with enoximone in volume and catecholamine refractory septic shock. *Pediatr Crit Care Med* 2003; 4:471–475
566. Morelli A, Donati A, Ertmer C, et al: Levosimendan for resuscitating the microcirculation in patients with septic shock: a randomized controlled study. *Crit Care* 2010; 14:R232
567. Namachivayam P, Crossland DS, Butt WW, et al: Early experience with Levosimendan in children with ventricular dysfunction. *Pediatr Crit Care Med* 2006; 7:445–448
568. Magliola R, Moreno G, Vassallo JC, et al: [Levosimendan, a new inotropic drug: experience in children with acute heart failure]. *Arch Argent Pediatr* 2009; 107:139–145
569. Harris E, Schulzke SM, Patole SK: Pentoxifylline in preterm neonates: a systematic review. *Paediatr Drugs* 2010; 12:301–311
570. Meyer DM, Jessen ME: Results of extracorporeal membrane oxygenation in children with sepsis. The Extracorporeal Life Support Organization. *Ann Thorac Surg* 1997; 63:756–761
571. Goldman AP, Kerr SJ, Butt W, et al: Extracorporeal support for intractable cardiorespiratory failure due to meningococcal disease. *Lancet* 1997; 349:466–469
572. Skinner SC, Iacono JA, Ballard HO, et al: Improved survival in venovenous vs venoarterial extracorporeal membrane oxygenation for pediatric noncardiac sepsis patients: a study of the Extracorporeal Life Support Organization registry. *J Pediatr Surg* 2012; 47:63–67
573. Domico MB, Ridout DA, Bronicki R, et al: The impact of mechanical ventilation time before initiation of extracorporeal life support on

- survival in pediatric respiratory failure: a review of the Extracorporeal Life Support Registry. *Pediatr Crit Care Med* 2012; 13:16–21
574. Bartlett RH: Extracorporeal support for septic shock. *Pediatr Crit Care Med* 2007; 8:498–499
575. MacLaren G, Butt W, Best D, et al: Central extracorporeal membrane oxygenation for refractory pediatric septic shock. *Pediatr Crit Care Med* 2011; 12:133–136
576. Flagg A, Danziger-Isakov L, Foster C, et al: Novel 2009 H1N1 influenza virus infection requiring extracorporeal membrane oxygenation in a pediatric heart transplant recipient. *J Heart Lung Transplant* 2010; 29:582–584
577. Kumar A, Zarychanski R, Pinto R, et al; Canadian Critical Care Trials Group H1N1 Collaborative: Critically ill patients with 2009 influenza A(H1N1) infection in Canada. *JAMA* 2009; 302:1872–1879
578. Pizarro CF, Troster EJ, Damiani D, et al: Absolute and relative adrenal insufficiency in children with septic shock. *Crit Care Med* 2005; 33:855–859
579. Riordan FA, Thomson AP, Ratcliffe JM, et al: Admission cortisol and adrenocorticotropic hormone levels in children with meningococcal disease: Evidence of adrenal insufficiency? *Crit Care Med* 1999; 27:2257–2261
580. De Kleijn ED, Joosten KF, Van Rijn B, et al: Low serum cortisol in combination with high adrenocorticotropic hormone concentrations are associated with poor outcome in children with severe meningococcal disease. *Pediatr Infect Dis J* 2002; 21:330–336
581. Markovitz BP, Goodman DM, Watson RS, et al: A retrospective cohort study of prognostic factors associated with outcome in pediatric severe sepsis: What is the role of steroids? *Pediatr Crit Care Med* 2005; 6:270–274
582. Pizarro CF, Troster EJ: Adrenal function in sepsis and septic shock. *J Pediatr (Rio J)* 2007; 83(5 Suppl):S155–S162
583. Zimmerman JJ, Williams MD: Adjunctive corticosteroid therapy in pediatric severe sepsis: Observations from the RESOLVE study. *Pediatr Crit Care Med* 2011; 12:2–8
584. Lacroix J, Hébert PC, Hutchison JS, et al; TRIPICU Investigators; Canadian Critical Care Trials Group; Pediatric Acute Lung Injury and Sepsis Investigators Network: Transfusion strategies for patients in pediatric intensive care units. *N Engl J Med* 2007; 356:1609–1619
585. Karam O, Tucci M, Ducruet T, et al; Canadian Critical Care Trials Group; PALISI Network: Red blood cell transfusion thresholds in pediatric patients with sepsis. *Pediatr Crit Care Med* 2011; 12:512–518
586. Church GD, Matthay MA, Liu K, et al: Blood product transfusions and clinical outcomes in pediatric patients with acute lung injury. *Pediatr Crit Care Med* 2009; 10:297–302
587. López-Herce Cid J, Bustinza Arriortúa A, Alcaraz Romero A, et al: [Treatment of septic shock with continuous plasmapheresis and hemodiafiltration]. *An Pediatr (Barc)* 2003; 59:491–496
588. Stegmayr BG, Banga R, Berggren L, et al: Plasma exchange as rescue therapy in multiple organ failure including acute renal failure. *Crit Care Med* 2003; 31:1730–1736
589. El-Nawawy A, Abbassy AA, El-Bordiny M, et al: Evaluation of early detection and management of disseminated intravascular coagulation among Alexandria University pediatric intensive care patients. *J Trop Pediatr* 2004; 50:339–347
590. Campanelli A, Kaya G, Ozsahin AH, et al: Purpura fulminans in a child as a complication of chickenpox infection. *Dermatology (Basel)* 2004; 208:262–264
591. Muntean W: Fresh frozen plasma in the pediatric age group and in congenital coagulation factor deficiency. *Thromb Res* 2002; 107 Suppl 1:S29–S32
592. Sánchez Miralles A, Reig Sáenz R, Marco Vera P, et al: [Abnormalities in coagulation and fibrinolysis in septic shock with purpura]. *An Esp Pediatr* 2002; 56:99–103
593. Hazelzet JA, Risseeuw-Appel IM, Kornelisse RF, et al: Age-related differences in outcome and severity of DIC in children with septic shock and purpura. *Thromb Haemost* 1996; 76:932–938
594. Churchwell KB, McManus ML, Kent P, et al: Intensive blood and plasma exchange for treatment of coagulopathy in meningococemia. *J Clin Apher* 1995; 10:171–177
595. Ala FA, Greaves M, Jones J, et al: Guidelines for the use of fresh frozen plasma. British Committee for Standards in Haematology, Working Party of the Blood Transfusion Task Force. *Curr Vasc Pharmacol* 2009; 7:110–119
596. Meyer B, Hellstern P: Recommendations for the use of therapeutic plasma. *Semin Nephrol* 2008; 28:447–456
597. Fortenberry JD: Pediatric critical care management of septic shock prior to acute kidney injury and renal replacement therapy. *Semin Nephrol* 2008; 28:447–456
598. O'Shaughnessy DF, Atterbury C, Bolton Maggs P, et al; British Committee for Standards in Haematology, Blood Transfusion Task Force. Practical guidelines for the clinical use of plasma. *Thromb Res* 2002; 107(Suppl 1):S53–S57
599. Muntean W, Schramm W, Seifried E, Solheim BG: Guideline for the use of fresh-frozen plasma. Medical Directors Advisory Committee, National Blood Transfusion Council. *S Afr Med J* 1998; 88:1344–1347
600. Nguyen TC, Han YY: Plasma exchange therapy for thrombotic microangiopathies. *Organogenesis* 2011; 7:28–31
601. van Deuren M, Brandtzaeg P, van der Meer JW: Update on meningococcal disease with emphasis on pathogenesis and clinical management. *Clin Microbiol Rev* 2000; 13:144–66, table of contents
602. Scharfman WB, Tillotson JR, Taft EG, et al: Plasmapheresis for meningococemia with disseminated intravascular coagulation. *N Engl J Med* 1979; 300:1277–1278
603. van Deuren M, Santman FW, van Dalen R, et al: Plasma and whole blood exchange in meningococcal sepsis. *Clin Infect Dis* 1992; 15:424–430
604. Bjorvatn B, Bjertnaes L, Fadnes HO, et al: Meningococcal septicaemia treated with combined plasmapheresis and leucapheresis or with blood exchange. *Br Med J (Clin Res Ed)* 1984; 288:439–441
605. Brandtzaeg P, Sirnes K, Folsland B, et al: Plasmapheresis in the treatment of severe meningococcal or pneumococcal septicaemia with DIC and fibrinolysis. Preliminary data on eight patients. *Scand J Clin Lab Invest Suppl* 1985; 178:53–55
606. Drapkin MS, Wisch JS, Gelfand JA, et al: Plasmapheresis for fulminant meningococemia. *Pediatr Infect Dis J* 1989; 8:399–400
607. Schött U, Björnsell-Ostling E: Sono-clot coagulation analysis and plasma exchange in a case of meningococcal septicaemia. *Can J Anaesth* 1995; 42:64–68
608. Mok Q, Butt W: The outcome of children admitted to intensive care with meningococcal septicaemia. *Intensive Care Med* 1996; 22:259–263
609. Kumar A, Kanagasundaram NS, Collyns TA, et al: Plasma exchange and haemodiafiltration in fulminant meningococcal sepsis. *Nephrol Dial Transplant* 1998; 13:484–487
610. Munteanu C, Bloodworth LL, Korn TH: Antithrombin concentrate with plasma exchange in purpura fulminans. *Pediatr Crit Care Med* 2000; 1:84–87
611. Busund R, Koukline V, Utrobin U, et al: Plasmapheresis in severe sepsis and septic shock: A prospective, randomised, controlled trial. *Intensive Care Med* 2002; 28:1434–1439
612. Randolph AG: Management of acute lung injury and acute respiratory distress syndrome in children. *Crit Care Med* 2009; 37:2448–2454
613. Krishnan J, Morrison W: Airway pressure release ventilation: A pediatric case series. *Pediatr Pulmonol* 2007; 42:83–88
614. Ten IS, Anderson MR: Is high-frequency ventilation more beneficial than low-tidal volume conventional ventilation? *Respir Care Clin N Am* 2006; 12:437–451
615. Rotta AT, Steinhorn DM: Is permissive hypercapnia a beneficial strategy for pediatric acute lung injury? *Respir Care Clin N Am* 2006; 12:371–387
616. Ben Jaballah N, Khaldi A, Mnif K, et al: High-frequency oscillatory ventilation in pediatric patients with acute respiratory failure. *Pediatr Crit Care Med* 2006; 7:362–367



617. Kam PC, Cardone D: Propofol infusion syndrome. *Anaesthesia* 2007; 62:690–701
618. Parke TJ, Stevens JE, Rice AS, et al: Metabolic acidosis and fatal myocardial failure after propofol infusion in children: Five case reports. *BMJ* 1992; 305:613–616
619. den Brinker M, Hokken-Koelega AC, Hazelzet JA, et al: One single dose of etomidate negatively influences adrenocortical performance for at least 24h in children with meningococcal sepsis. *Intensive Care Med* 2008; 34:163–168
620. Su F, Hammer GB: Dexmedetomidine: Pediatric pharmacology, clinical uses and safety. *Expert Opin Drug Saf* 2011; 10:55–66
621. Carcillo JA, Doughty L, Kofos D, et al: Cytochrome P450 mediated-drug metabolism is reduced in children with sepsis-induced multiple organ failure. *Intensive Care Med* 2003; 29:980–984
622. Branco RG, Garcia PC, Piva JP, et al: Glucose level and risk of mortality in pediatric septic shock. *Pediatr Crit Care Med* 2005; 6:470–472
623. Faustino EV, Apkon M: Persistent hyperglycemia in critically ill children. *J Pediatr* 2005; 146:30–34
624. Jeschke MG, Kulp GA, Kraft R, et al: Intensive insulin therapy in severely burned pediatric patients: A prospective randomized trial. *Am J Respir Crit Care Med* 2010; 182:351–359
625. Day KM, Haub N, Betts H, et al: Hyperglycemia is associated with morbidity in critically ill children with meningococcal sepsis. *Pediatr Crit Care Med* 2008; 9:636–640
626. Garcia Branco R, Tasker RC, Ramos Garcia PC, et al: Glycemic control and insulin therapy in sepsis and critical illness. *J Pediatr (Rio J)* 2007; 83(5 Suppl):S128–S136
627. Verhoeven JJ, den Brinker M, Hokken-Koelega AC, et al: Pathophysiological aspects of hyperglycemia in children with meningococcal sepsis and septic shock: A prospective, observational cohort study. *Crit Care* 2011; 15:R44
628. Vlasselaers D, Milants I, Desmet L, et al: Intensive insulin therapy for patients in paediatric intensive care: A prospective, randomised controlled study. *Lancet* 2009; 373:547–556
629. Foland JA, Fortenberry JD, Warshaw BL, et al: Fluid overload before continuous hemofiltration and survival in critically ill children: A retrospective analysis. *Crit Care Med* 2004; 32:1771–1776
630. Santiago MJ, López-Herce J, Urbano J, et al: Clinical course and mortality risk factors in critically ill children requiring continuous renal replacement therapy. *Intensive Care Med* 2010; 36:843–849
631. Brophy PD: Renal supportive therapy for pediatric acute kidney injury in the setting of multiorgan dysfunction syndrome/sepsis. *Semin Nephrol* 2008; 28:457–469
632. Krafte-Jacobs B, Sivit CJ, Mejia R, et al: Catheter-related thrombosis in critically ill children: Comparison of catheters with and without heparin bonding. *J Pediatr* 1995; 126:50–54
633. Pierce CM, Wade A, Mok Q: Heparin-bonded central venous lines reduce thrombotic and infective complications in critically ill children. *Intensive Care Med* 2000; 26:967–972
634. Chaïbou M, Tucci M, Dugas MA, et al: Clinically significant upper gastrointestinal bleeding acquired in a pediatric intensive care unit: A prospective study. *Pediatrics* 1998; 102(4 Pt 1):933–938
635. Gauvin F, Dugas MA, Chaïbou M, et al: The impact of clinically significant upper gastrointestinal bleeding acquired in a pediatric intensive care unit. *Pediatr Crit Care Med* 2001; 2:294–298
636. Sheridan RL, Yu YM, Prelack K, et al: Maximal parenteral glucose oxidation in hypermetabolic young children: A stable isotope study. *JPEN J Parenter Enteral Nutr* 1998; 22:212–216

## APPENDIX A

### 2012 Surviving Sepsis Campaign Guidelines Committee

R. Phillip Dellinger, (Co-Chair); Rui Moreno (Co-Chair); Leanne Aitken,<sup>1</sup> Hussain Al Rahma,<sup>2</sup> Derek C. Angus, Dijillali Annane, Richard J. Beale, Gordon R. Bernard, Paolo Biban,<sup>3</sup> Julian F. Bion, Thierry Calandra, Joseph A. Carcillo, Terry P. Clemmer, Clifford S. Deutschman, J.V. Divatia,<sup>4</sup> Ivor S. Douglas, Bin Du,<sup>5</sup> Seitaro Fujishima, Satoshi Gando,<sup>6</sup> Herwig Gerlach, Caryl Goodyear-Bruch,<sup>7</sup> Gordon Guyatt, Jan A. Hazelzet, Hiroyuki Hirasawa,<sup>8</sup> Steven M. Hollenberg, Judith Jacobi, Roman Jaeschke, Ian Jenkins,<sup>9</sup> Edgar Jimenez,<sup>10</sup> Alan E. Jones,<sup>11</sup> Robert M. Kacmarek, Winfried Kern,<sup>12</sup> Ruth M. Kleinpell,<sup>1</sup> Shin Ok Koh,<sup>13</sup> Joji Kotani, Mitchell Levy,<sup>14</sup> Flavia Machado,<sup>15</sup> John Marini, John C. Marshall, Henry Masur, Sangeeta Mehta, John Muscedere,<sup>16</sup> Lena M. Napolitano,<sup>17</sup> Mark E. Nunnally, Steven M. Opal,<sup>18</sup> Tiffany M. Osborn,<sup>19</sup> Margaret M. Parker, Joseph E. Parrillo, Haibo Qiu,<sup>20</sup> Adrienne G. Randolph, Konrad Reinhart,<sup>21</sup> Jordi Rello, Ederlon Resende,<sup>22</sup> Andrew Rhodes,<sup>23</sup> Emanuel P. Rivers, Gordon D. Rubenfeld,<sup>24</sup> Christa A. Schorr, Jonathan E. Sevransky, Khalid Shukri,<sup>25</sup> Eliezer Silva, Mark D. Soth, Charles L. Sprung, Ann E. Thompson,<sup>26</sup> Sean R. Townsend, Jeffery S. Vender,<sup>27</sup> Jean-Louis Vincent, Steve A. Webb,<sup>28</sup> Tobias Welte,<sup>29</sup> Janice L. Zimmerman.

<sup>1</sup>World Federation of Critical Care Nurses; <sup>2</sup>Emirates Intensive Care Society; <sup>3</sup>European Society of Pediatric and Neonatal

Intensive Care; <sup>4</sup>Indian Society of Critical Care Medicine; <sup>5</sup>Chinese Society of Critical Care Medicine; <sup>6</sup>Japanese Association for Acute Medicine; <sup>7</sup>American Association of Critical-Care Nurses; <sup>8</sup>Japanese Society of Intensive Care Medicine; <sup>9</sup>Society of Hospital Medicine; <sup>10</sup>World Federation of Societies of Intensive and Critical Care Medicine; <sup>11</sup>Society of Academic Emergency Medicine; <sup>12</sup>European Society of Clinical Microbiology and Infectious Diseases; <sup>13</sup>Asia Pacific Association of Critical Care Medicine; <sup>14</sup>Society of Critical Care Medicine; <sup>15</sup>Latin American Sepsis Institute; <sup>16</sup>Canadian Critical Care Society; <sup>17</sup>Surgical Infection Society; <sup>18</sup>Infectious Diseases Society of America; <sup>19</sup>American College of Emergency Physicians; <sup>20</sup>Chinese Society of Critical Care-China Medical Association; <sup>21</sup>German Sepsis Society; <sup>22</sup>Brazilian Society of Critical Care (AMIB); <sup>23</sup>European Society of Intensive Care Medicine; <sup>24</sup>American Thoracic Society; <sup>25</sup>International Pan Arab Critical Care Medicine Society; <sup>26</sup>Pediatric Acute Lung Injury and Sepsis Investigators; <sup>27</sup>American College of Chest Physicians; <sup>28</sup>Australian and New Zealand Intensive Care Society; <sup>29</sup>European Respiratory Society; World Federation of Pediatric Intensive and Critical Care Societies.

### Pediatric Subgroup

Jan A. Hazelzet, Adrienne G. Randolph, Margaret M. Parker, Ann E. Thompson, Paolo Biban, Alan Duncan, Cristina Mangia, Niranjan Kissoon, and Joseph A. Carcillo (Head).

**APPENDIX B**  
**Conflict of Interest Process**

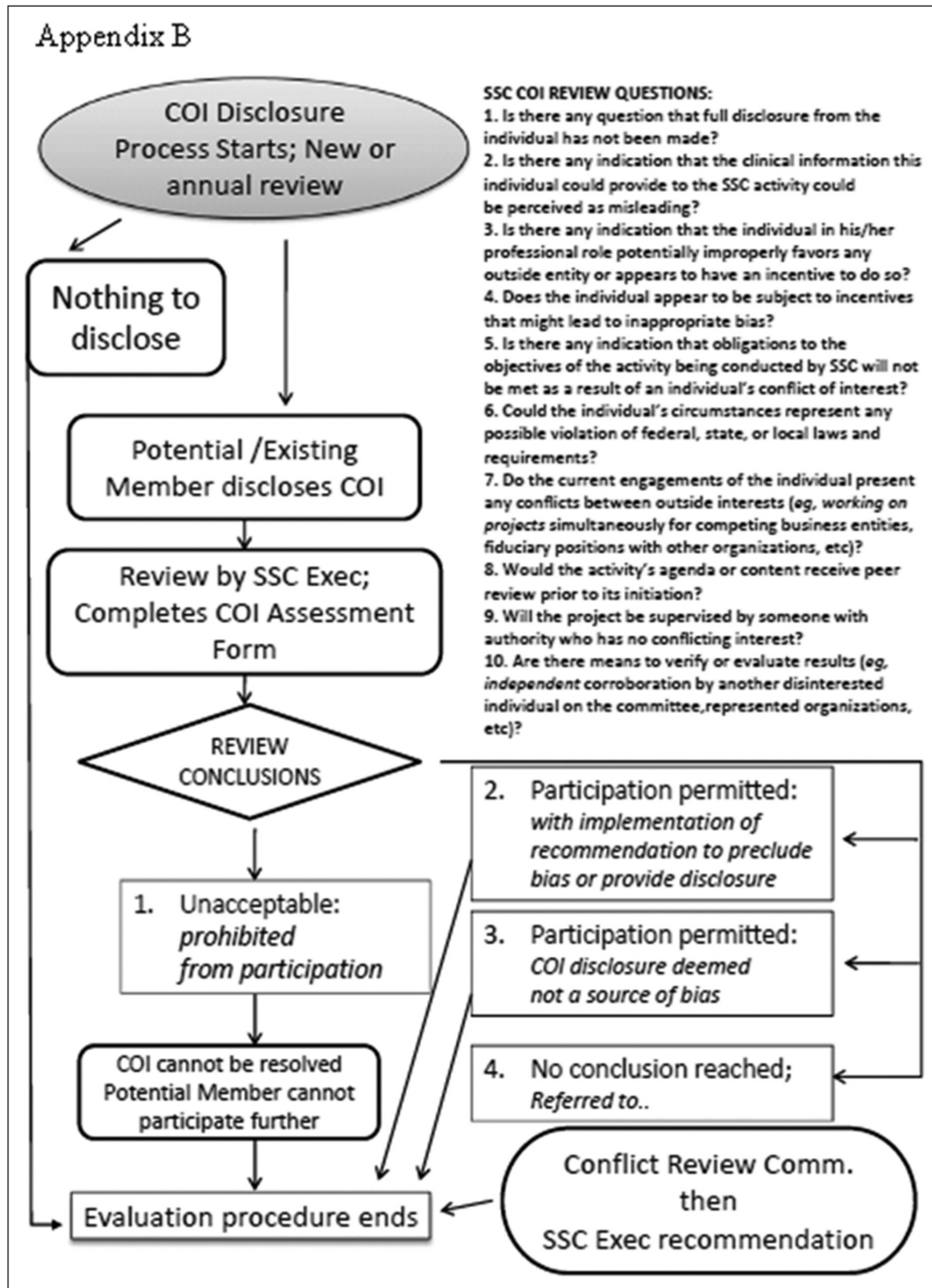

## APPENDIX C ARDSnet Ventilator Management

Assist control mode—volume ventilation														
Reduce tidal volume to 6 mL/kg lean body weight														
Keep plateau pressure < 30 cm H <sub>2</sub> O														
–Reduce tidal volume as low as 4 mL/kg predicted body weight to limit plateau pressure														
Maintain Sa <sub>o</sub> <sub>2</sub> /Sp <sub>o</sub> <sub>2</sub> between 88% and 95%														
Anticipated PEEP settings at various F <sub>io</sub> <sub>2</sub> requirements														
F <sub>io</sub> <sub>2</sub>	0.3	0.4	0.4	0.5	0.5	0.6	0.7	0.7	0.7	0.8	0.9	0.9	0.9	1.0
PEEP	5	5	8	8	10	10	10	12	14	14	14	16	18	20-24
Predicted Body Weight Calculation														
Male— 50 + 2.3 [height (inches) – 60] or 50 + 0.91 [height (cm) – 152.4]														
Female—45.5 + 2.3 [height (inches) – 60] or 45.5 + 0.91 [height (cm) – 152.4]														

Sa<sub>o</sub><sub>2</sub> = arterial oxygen saturation, PEEP = positive end-expiratory pressure, Sp<sub>o</sub><sub>2</sub> = oxygen saturation on pulse oximetry. Adapted from Acute Respiratory Distress Syndrome Network. Ventilation with lower tidal volumes as compared with traditional tidal volumes for acute lung injury and the acute respiratory distress syndrome.

*N Engl J Med* 2000; 342:1301–1308.

## APPENDIX D Summary of Ventilator Procedures in the Higher PEEP Groups of the ALVEOLI Trial

Procedure	Value													
Ventilator mode	Volume assist/control													
Tidal volume goal	6 mL/kg of predicted body weight													
Plateau pressure goal	≤ 30 cm H <sub>2</sub> O													
Ventilator rate and pH goal	6–35, adjusted to achieve arterial pH ≥ 7.30 if possible													
Inspiration expiration time	1:1–1:3													
Oxygenation goal														
Pa <sub>o</sub> <sub>2</sub>	55–80 mm Hg													
Sp <sub>o</sub> <sub>2</sub>	88%–95%													
Weaning	Weaning attempted by means of pressure support when level of arterial oxygenation acceptable with PEEP < 8 cm H <sub>2</sub> O and F <sub>io</sub> <sub>2</sub> < 0.40													
Allowable combinations of PEEP and F <sub>io</sub> <sub>2</sub> <sup>a</sup>														
Higher PEEP group (after protocol changed to use higher levels of PEEP)														
F <sub>io</sub> <sub>2</sub>	0.3	0.3	0.4	0.4	0.5	0.5	0.5–0.8	0.8	0.9	0.9	0.9	0.9	0.9	1
PEEP	12	14	14	16	16	18	20	20	22	22	22	22	22	22–24

Note: Complete ventilator procedures and eligibility criteria can be found at [www.ardsnet.org](http://www.ardsnet.org).

Sp<sub>o</sub><sub>2</sub> = oxyhemoglobin saturation as measured by pulse oximetry, F<sub>io</sub><sub>2</sub> = fraction of inspired oxygen, PEEP = positive end-expiratory pressure.

<sup>a</sup>In both study groups (lower and higher PEEP), additional increases in PEEP to 34 cm H<sub>2</sub>O were allowed but not required after F<sub>io</sub><sub>2</sub> had been increased to 1.0, according to the protocol.

Adapted from Brower RG, Lanken PN, MacIntyre N, et al: Higher vs. lower positive end-expiratory pressures in patients with the acute respiratory distress syndrome.

*N Engl J Med*. 2004; 351(4):327–336.



Appendix 6, Instruction in the Event of a PMX Cartridge Malfunction or Defect



**Instruction in the Event of a PMX Cartridge Malfunction or Defect**

---

<b>Protocol No.</b>	<b>SDI-PMX-NA001</b>
<b>Title</b>	Evaluating the use of Polymyxin B Hemoperfusion in a Randomized controlled Trial of Adults Treated for Endotoxemia and Septic Shock
<b>Sponsor</b>	Spectral Diagnostics, Inc 135-2 The West Mall Toronto, Ontario M9C 1C2 Canada
<b>Version</b>	<b>Final v1.0</b>
<b>Version Date</b>	<b>19 Mar 2014</b>

---

Approved by:

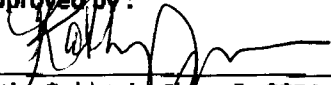
  
Kathy Goldstein, PharmD, CCRA  
Project Manager for SDI-PMX-NA001  
Amarex Clinical Research

19 Mar 2014

Date

Approved by:

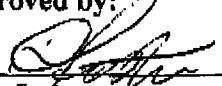
  
Debra Foster  
Vice President, Clinical Development  
Spectral Diagnostics, Inc.

19 MAR 2014

Date

## Instruction in the Event of a PMX Cartridge Malfunction or Defect

### **Definitions:**

**DEVICE DEFECT:** Device defects are identified upon inspection of the cartridge on receipt, prior to beginning treatment.

Examples of device defects include discoloration of the brown sterility mark, a crack or leak in the plastic casing and/or a bubble or suspended substance within the cartridge interior. **This is termed a PRODUCT COMPLAINT.**

**ADVERSE DEVICE EFFECT:** is an equivalent term for an AE (an unwanted medical occurrence in a subject) suspected to have been caused by an investigational device. For the purposes of this study, the device under investigation is the PMX cartridge.

According to the Toraymyxin Instructions for Use, there are known (anticipated) Adverse Device Effects [ADE]. These may or may not be associated with adverse effects on the patient. If an ADE occurs that also has an impact on the health and safety or any life-threatening problem then the term Serious adverse device effect [SADE] is used.

**Known (anticipated) adverse device effects:** These are malfunctions in the cartridge after treatment has been initiated (i.e., blood has hit the cartridge). Examples of anticipated adverse device effects include the following:

- i. Elevation of inlet pressure
- ii. Bubble generation
- iii. Cartridge leak
- iv. Cartridge break
- v. Cartridge clotting
- vi. Suspended substance

**SERIOUS ADVERSE DEVICE EFFECT:** A Serious Adverse Device Effect (SADE) is any adverse effect on the health and safety or any life-threatening problem or death caused by or associated with a device, and is suspected to have been caused by one of the device effects listed above.

SADEs are reported on the Safety Event form using the same process as an SAE.

### EUPHRATES Study Reporting Processes and CRF completion guidelines:

**If there is a DEVICE DEFECT, i.e. it is found BEFORE a patient's blood has reached the cartridge:**

- I. Reporting a product complaint:
  - a. The site should directly notify the Sponsor Quality Assurance (QA) through the product complaint line at 1-888-426-4264.

- b. Please have the following information ready:
  - i. Site and subject ID (note that the QA department is UNBLINDED)
  - ii. Serial number and lot number with expiry date of the cartridge with details of the defect.
- II. Recording the DEVICE DEFECT on the CRF:
  - a. CRF pages 26 or 28- PMX cartridge/Sham perfusion administration pages.
- III. Return of PMX cartridge:
  - a. Please refer to the Nephrology or Operations Manual for detailed instructions on how to return a defective PMX cartridge.

**If there is an ADVERSE DEVICE EFFECT, i.e., it occurred AFTER a patient's blood has reached the cartridge.**

- I. Reporting an Adverse Device Effect (ADE): Contact the Triage Center (TC) at 1-877-340-6211 and request to speak with the on-call Medical Monitor. The Amarex Medical Monitor will contact the site to determine the nature of the effect (SADE versus ADE).
  - a. If the device effect is an SADE:
    - i. Safety reporting is required within 24 hours of the Investigator's first knowledge of the event (or at the latest on the following working day)
    - ii. Amarex safety department will instruct the site to report the event via Safety Event form
  - b. If the device effect is an ADE:
    - i. Immediate reporting not required: Event was determined to have no impact on safety or welfare of subject. The ADE term (i.e., cartridge clot) needs to be captured on the AE CRF page (p. 86)\*
- II. Recording an ADE/SADE:
  - a. CRF page 86 (AE): ADE / SADE term to be captured on AE CRF page (note: SADE's will require immediate reporting as described above)
- III. Return of PMX Cartridge: because these cartridges will be contaminated by the patient's blood, they should be disposed of on-site per the site's hazardous material destruction standards and DO NOT need to be returned to the manufacturer.

\*Medical Monitor to generate TCR from conversation with the site. The Project Manager or Clinical Lead to communicate with Spectral QA department so that a product complaint can be logged