

## **SUPPLEMENTAL DATA**

### **A Phase I Trial of Low Dose Inhaled Carbon Monoxide in Sepsis-Induced ARDS**

Laura E. Fredenburgh<sup>1\*</sup>, Mark A. Perrella<sup>1,2</sup>, Diana Barragan Bradford<sup>1</sup>, Dean R. Hess<sup>3,4</sup>, Elizabeth Peters<sup>5</sup>, Karen E. Welty-Wolf<sup>6</sup>, Bryan D. Kraft<sup>6</sup>, R. Scott Harris<sup>7</sup>, Rie Maurer<sup>8</sup>, Kiichi Nakahira<sup>5</sup>, Clara Oromendia<sup>9</sup>, John D. Davies<sup>10</sup>, Angelica Higuera<sup>1</sup>, Kristen T. Schiffer<sup>5</sup>, Joshua A. Englert<sup>1</sup>, Paul B. Dieffenbach<sup>1</sup>, David A. Berlin<sup>5</sup>, Susan Lagambina<sup>11</sup>, Mark Bouthot<sup>11</sup>, Andrew I. Sullivan<sup>11</sup>, Paul F. Nuccio<sup>11</sup>, Mamary T. Kone<sup>7</sup>, Mona Malik<sup>6</sup>, Maria Angelica Pabon Porras<sup>5</sup>, Eli Finkelsztein<sup>5</sup>, Tilo Winkler<sup>3</sup>, Shelley Hurwitz<sup>8</sup>, Charles N. Serhan<sup>12</sup>, Claude A. Piantadosi<sup>6</sup>, Rebecca M. Baron<sup>1</sup>, B. Taylor Thompson<sup>7</sup>, Augustine M.K. Choi<sup>5\*</sup>

## **SUPPLEMENTAL DATA**

### **TABLE OF CONTENTS**

#### **1. Supplemental Figures**

Supplemental Figure 1. Arterial blood gas parameters by subject- Cohort 1

Supplemental Figure 2. Arterial blood gas parameters by subject- Cohort 2

Supplemental Figure 3. Carboxyhemoglobin levels by day

Supplemental Figure 4. Carboxyhemoglobin levels by subject

Supplemental Figure 5. Baseline mtDNA, RIPK3, and IL-18 levels

Supplemental Figure 6. Baseline and post-treatment day 2 mtDNA levels

Supplemental Figure 7. Change in circulating mtDNA levels

Supplemental Figure 8. Change in circulating RIPK3 levels

Supplemental Figure 9. Change in circulating IL-18 levels

Supplemental Figure 10. Coburn-Forster-Kane (CFK) equation

#### **2. Supplemental Tables**

Supplemental Table 1. Site of infection and microbiology results

Supplemental Table 2. Arterial blood gas parameters before and after treatment

Supplemental Table 3. Study drug holds per participant

Supplemental Table 4. Cohort 1 carboxyhemoglobin levels

Supplemental Table 5. Cohort 2 carboxyhemoglobin levels

Supplemental Table 6. Comparison of carboxyhemoglobin levels between groups

Supplemental Table 7. Baseline and post-treatment day 2 mtDNA levels

Supplemental Table 8. Luminex biomarker panel

Supplemental Table 9. Inclusion and exclusion criteria

Supplemental Table 10. Pre-specified administration-associated AEs

#### **3. Study Protocol**

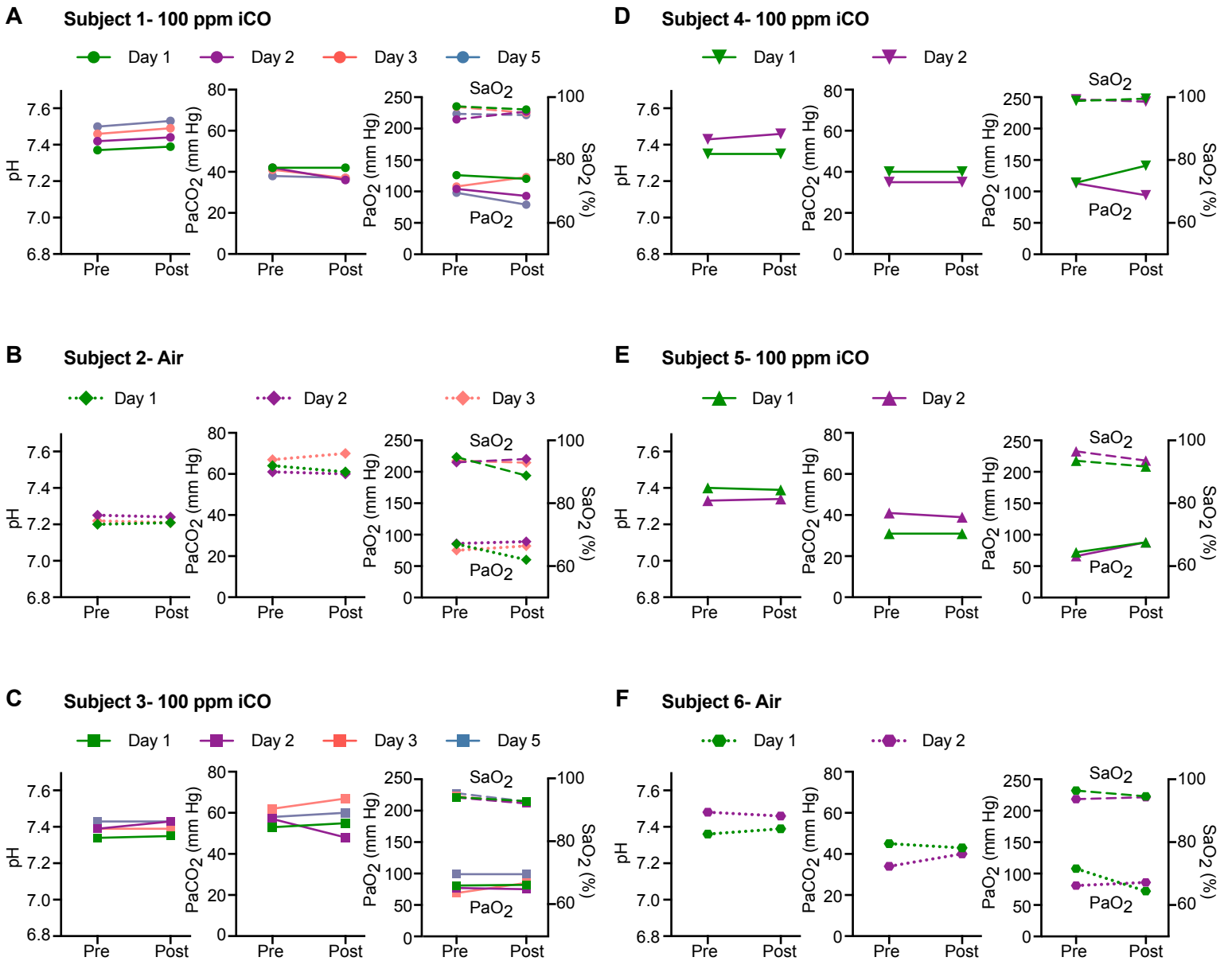

Supplemental Figure 1. Arterial blood gas parameters pre- and post-treatment with iCO vs. placebo air. Arterial pH, PaCO<sub>2</sub>, PaO<sub>2</sub>, and SaO<sub>2</sub> pre-treatment and post-treatment for each participant in Cohort 1 on each day of treatment.

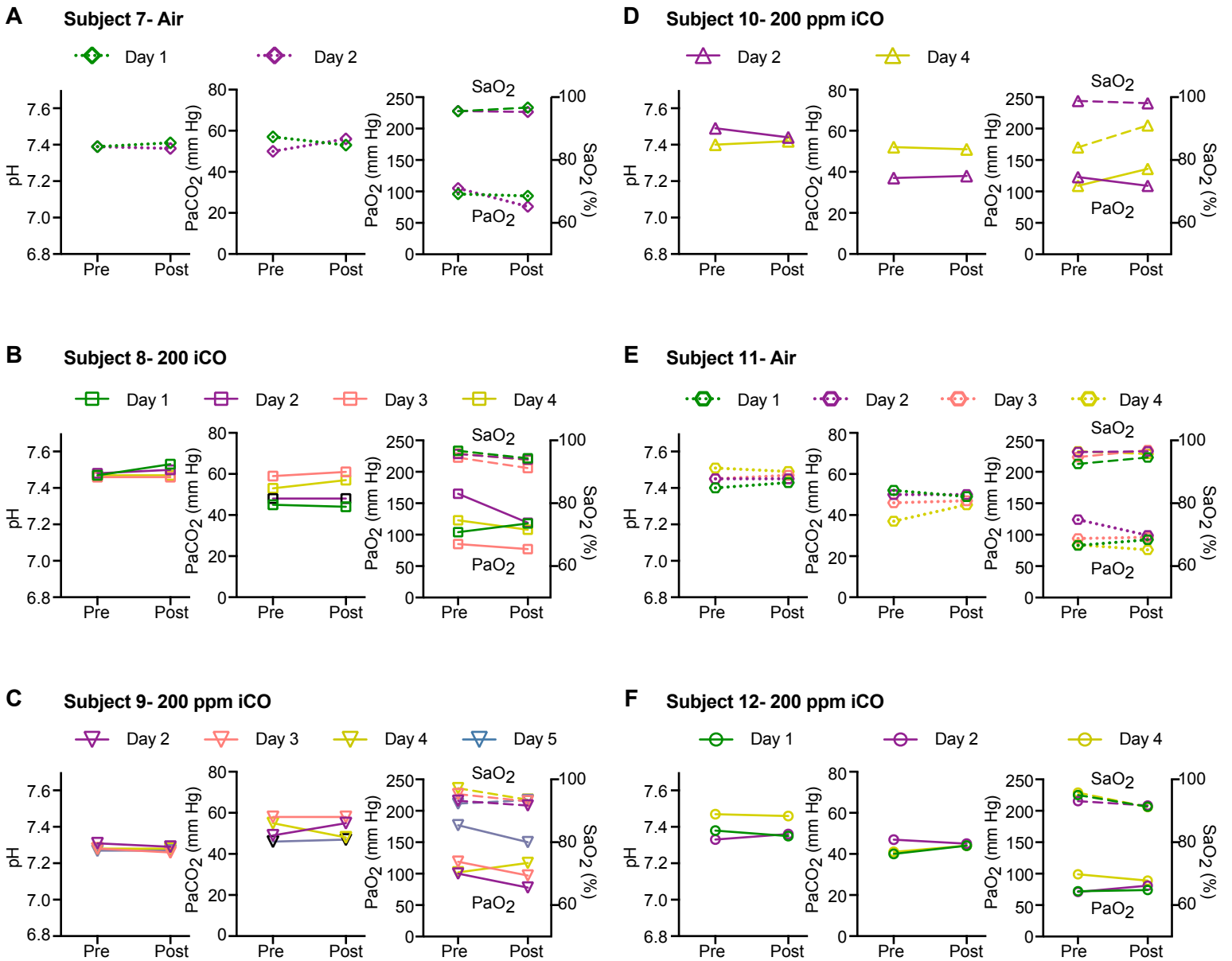

Supplemental Figure 2. Arterial blood gas parameters pre- and post-treatment with iCO vs. placebo air. Arterial pH, PaCO<sub>2</sub>, PaO<sub>2</sub>, and SaO<sub>2</sub> pre-treatment and post-treatment for each participant in Cohort 2 on each day of treatment.

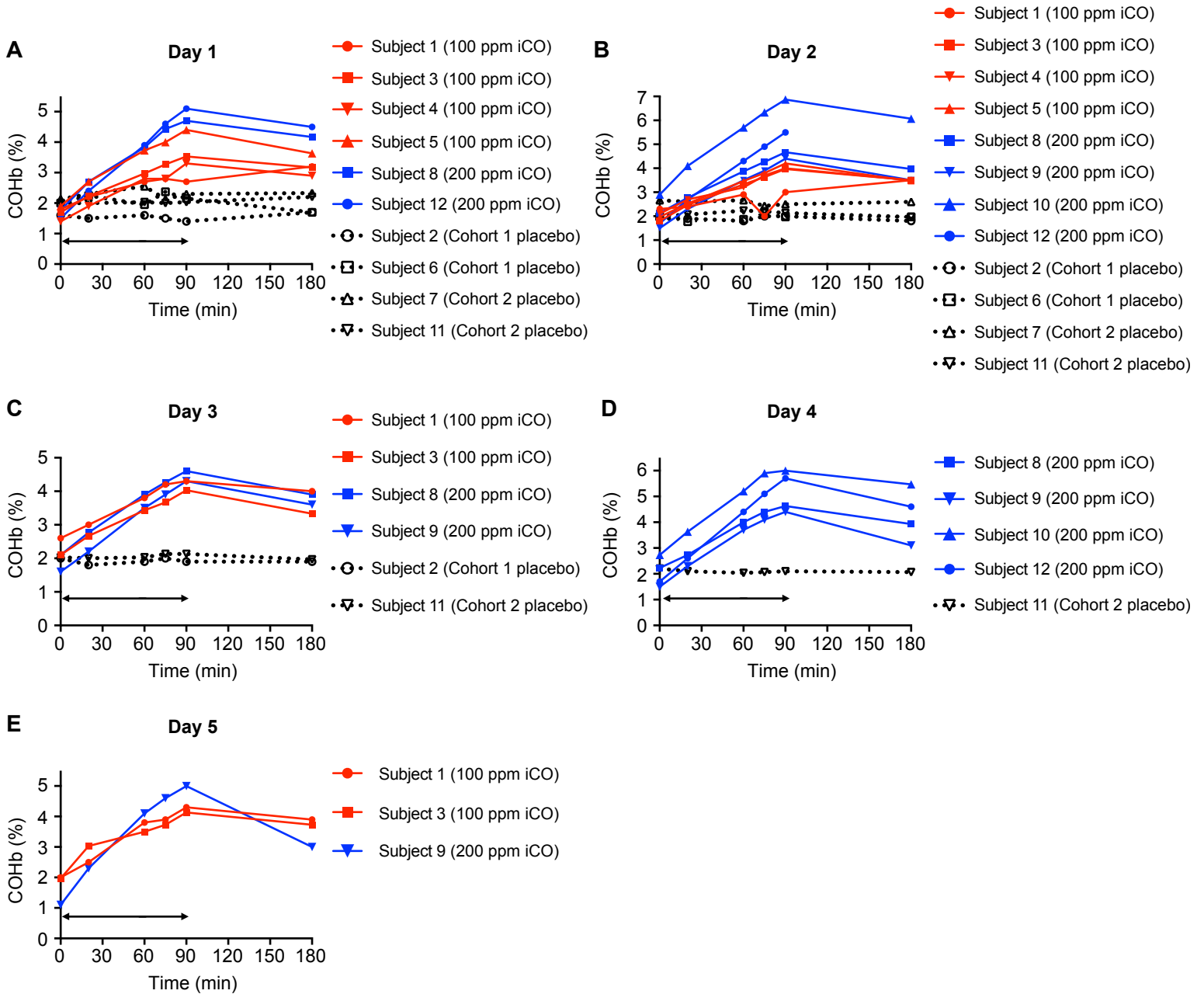

**Supplemental Figure 3. Carboxyhemoglobin levels by day for each individual subject.** Arterial COHb levels for each individual subject at 0, 20, 60, 75, 90, and 180 minutes on (A) Day 1, (B) Day 2, (C) Day 3, (D) Day 4, and (E) Day 5. Data are the means of triplicate values for each subject at each time point on each day of treatment. Arrows indicate duration of treatment.

Supplemental Figure 4. Fredenburgh *et al.*

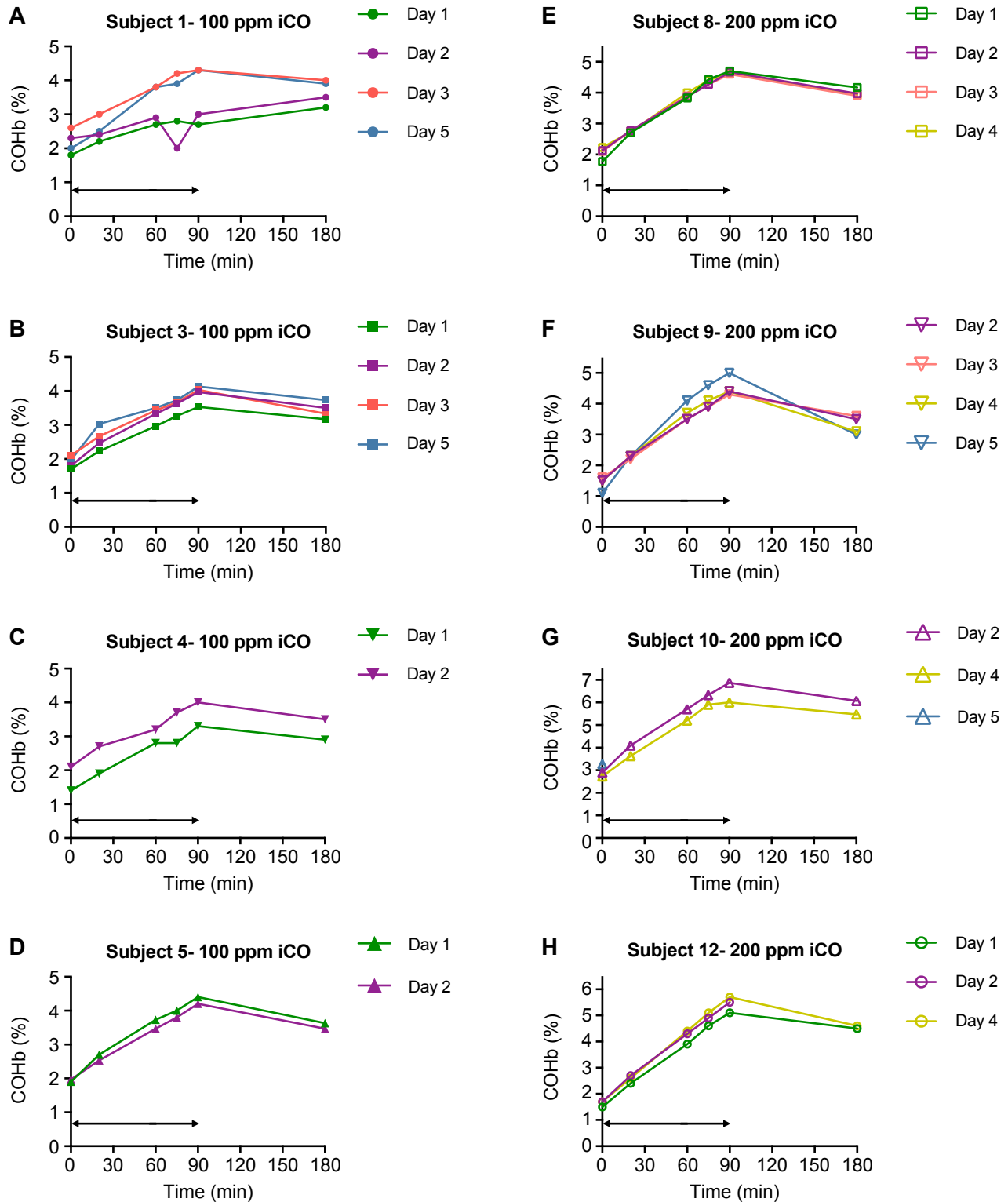

**Supplemental Figure 4. Carboxyhemoglobin levels by subject for CO-treated participants.** Arterial COHb levels at 0, 20, 60, 75, 90, and 180 minutes for each subject in Cohort 1 treated with 100 ppm iCO (**A-D**) and each subject in Cohort 2 treated with 200 ppm iCO (**E-H**) for each day of treatment. Data are mean of triplicate values for each subject at each time point on each day of treatment. Arrows indicate duration of treatment.

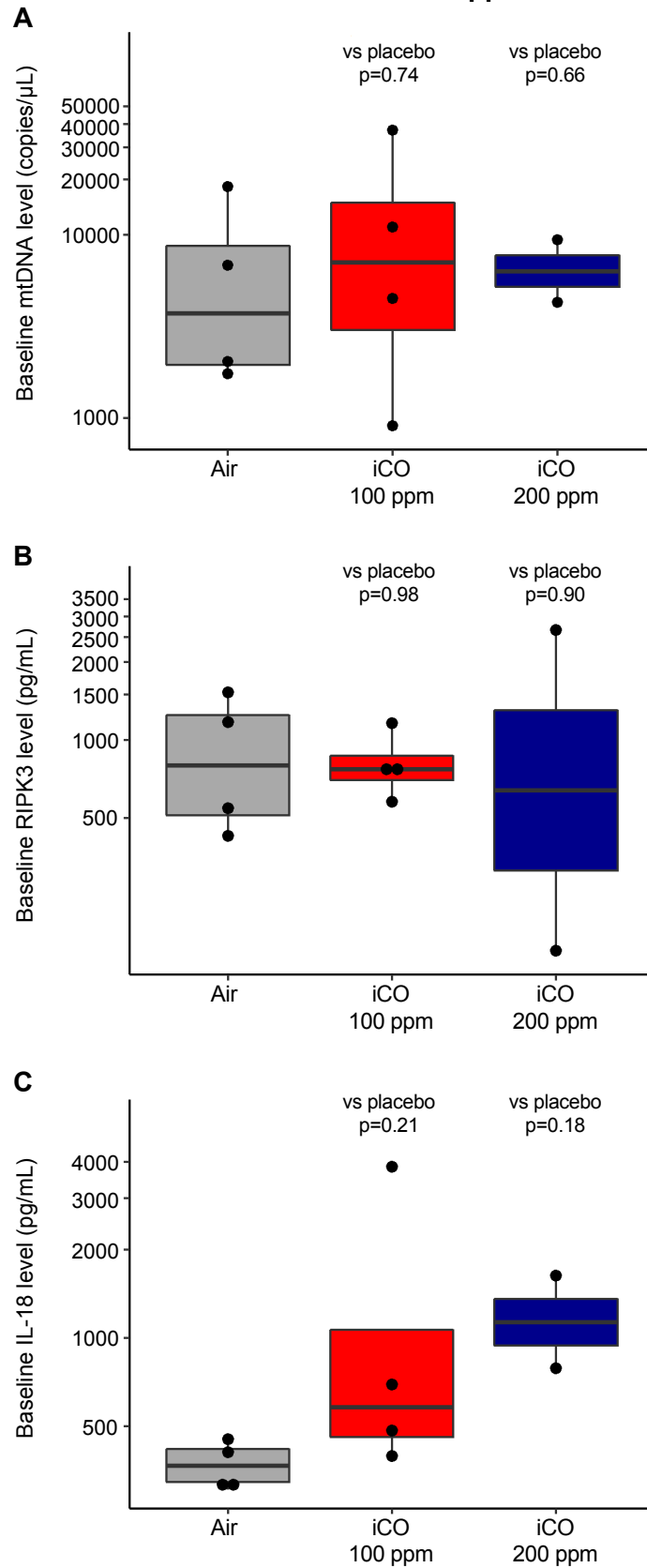

**Supplemental Figure 5. No difference in baseline mtDNA, RIPK3, and IL-18 levels.** Circulating mitochondrial DNA (mtDNA) (A), RIPK3 (B), and IL-18 (C) levels were measured in plasma pre-treatment on study day 1 in iCO-treated subjects (100 ppm and 200 ppm) and placebo-treated subjects. Statistical significance was determined in a pairwise manner using t-tests. Boxplots show 25th, median, and 75th percentiles.

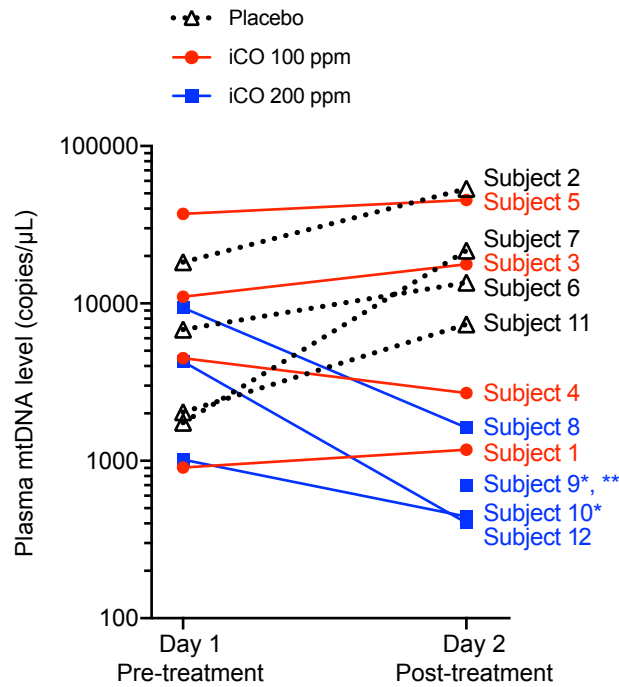

**Supplemental Figure 6. Baseline and post-treatment day 2 plasma mtDNA levels in iCO-treated subjects and placebo-treated subjects.** Plasma levels of mtDNA were measured in subjects pre-treatment on day 1 and post-treatment on day 2. \*Subjects 9 and 10 had a study hold on day 1. All other subjects (n=10) were treated on study days 1 and 2. \*\*Baseline mtDNA levels were not available for Subject 9.





Supplemental Figure 8. Fredenburgh et al.

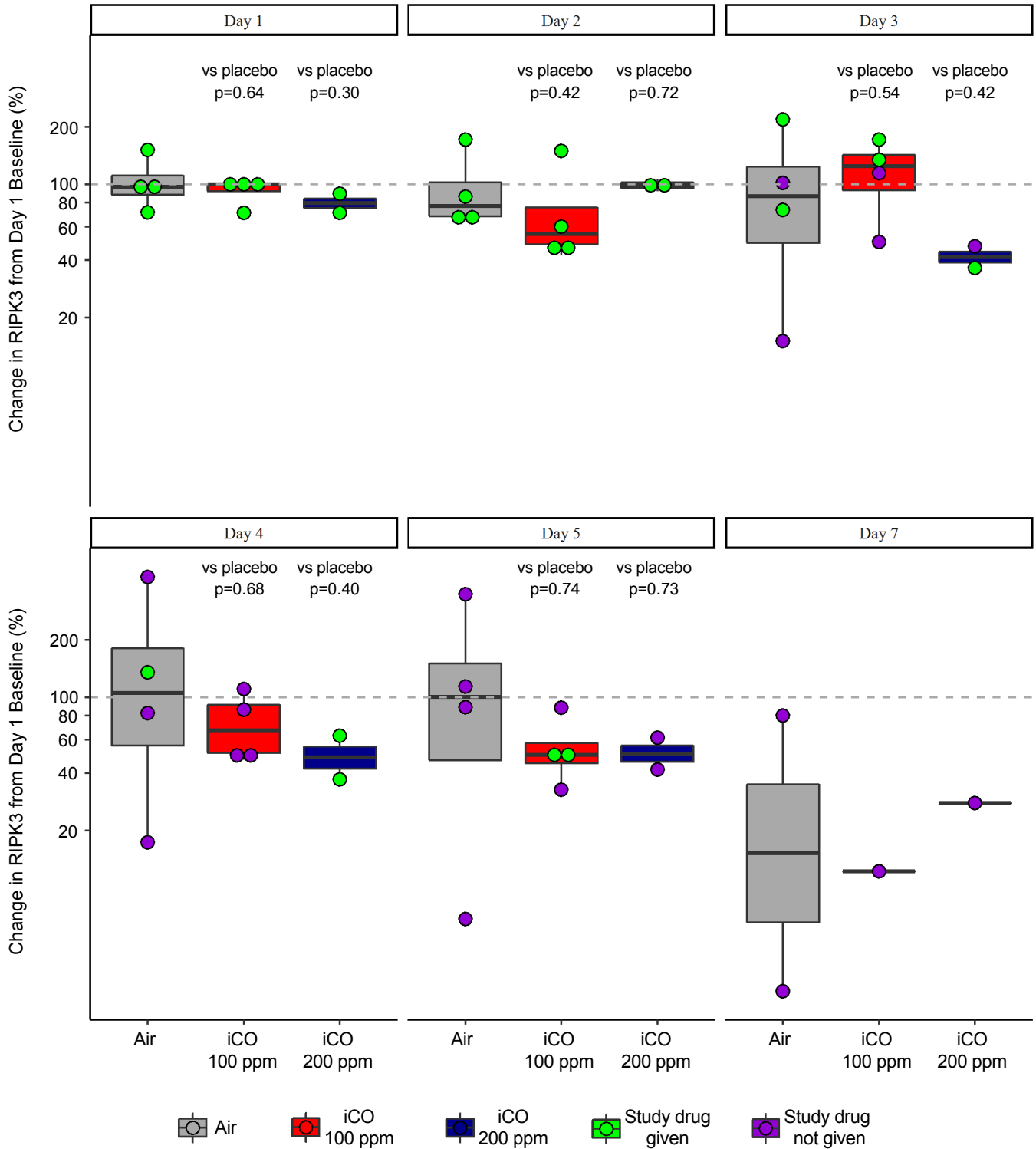

**Supplemental Figure 8. No difference in circulating RIPK3 levels among iCO- and placebo-treated subjects.** Plasma levels of RIPK3 were measured in subjects pre-treatment on day 1, post-treatment on days 1, 2, 3, 4, and 5 (n=10), and on day 7 in a subset of patients (n=5). Mean changes in RIPK3 in iCO-treated subjects (100 ppm and 200 ppm) were compared with changes in placebo-treated subjects in a pairwise manner using t-tests. Boxplots show 25th, median, and 75th percentiles.

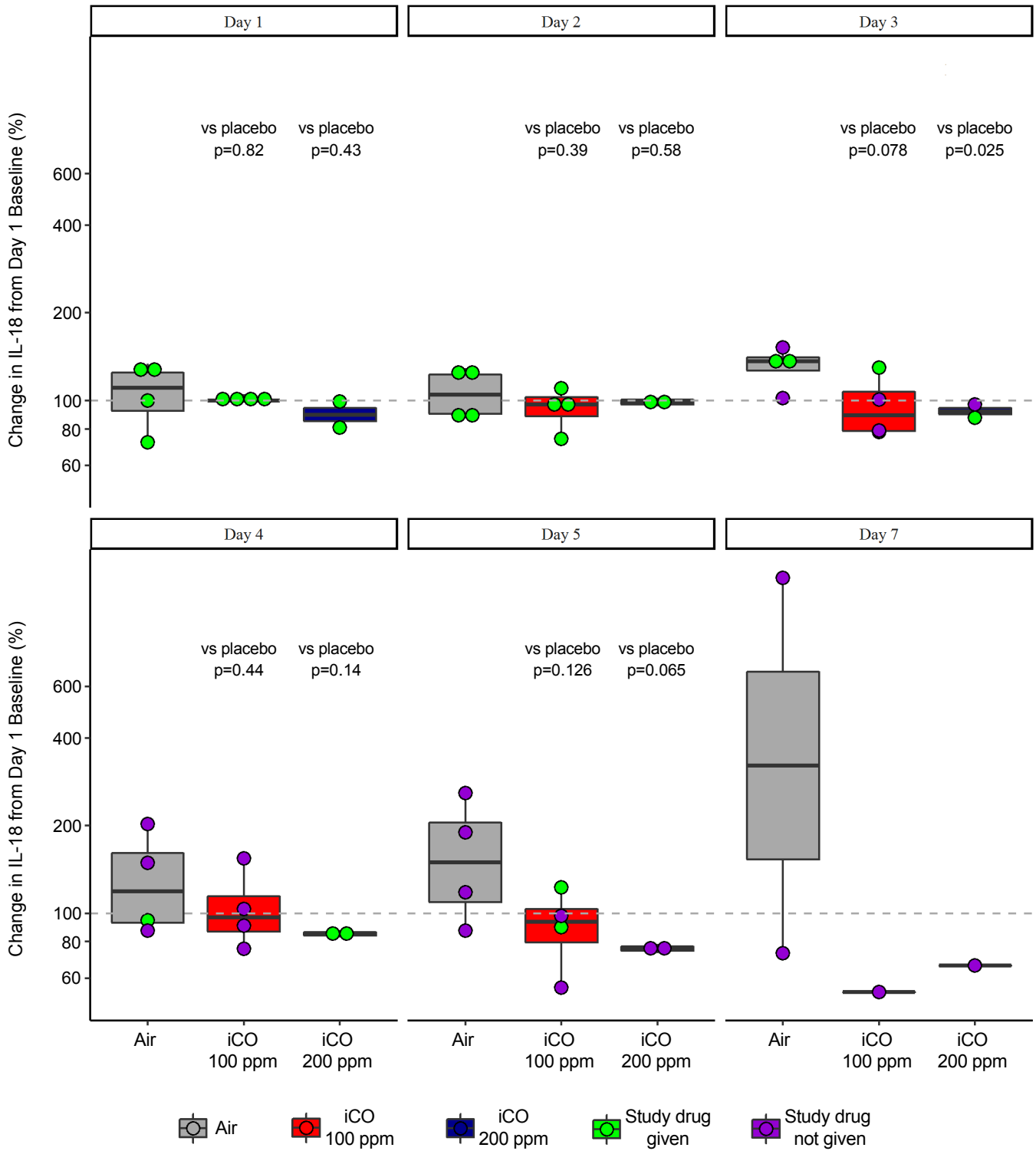

**Supplemental Figure 9. No difference in circulating IL-18 levels among iCO- and placebo-treated subjects.** Plasma levels of IL-18 were measured in subjects pre-treatment on day 1, post-treatment on days 1, 2, 3, 4, and 5 (n=10), and on day 7 in a subset of patients (n=5). Mean changes in IL-18 in iCO-treated subjects (100 ppm and 200 ppm) were compared with changes in placebo-treated subjects in a pairwise manner using t-tests. Boxplots show 25th, median, and 75th percentiles.

$$\frac{(A[\text{HbCO}]_t - B\dot{V}_{\text{CO}} - P_{\text{Ico}})}{(A[\text{HbCO}]_0 - B\dot{V}_{\text{CO}} - P_{\text{Ico}})} = \exp\left(-\frac{tA}{VbB}\right)$$

$A = P_{\text{C}_{\text{O}_2}} / M [\text{HbO}_2]$ ;  $B = 1/DL_{\text{CO}} + PL/\dot{V}_A$ ;  $M$  = ratio of the affinity of blood for CO to that for O<sub>2</sub>;  $[\text{HbCO}]_t$  = CO volume per mL of blood at time  $t$ ;  $[\text{HbCO}]_0$  = CO volume per mL of blood at time 0;  $P_{\text{C}_{\text{O}_2}}$  = average partial pressure of oxygen in lung capillaries;  $\dot{V}_{\text{CO}}$  = rate of endogenous CO production;  $DL_{\text{CO}}$  = diffusivity of the lung for CO;  $PL$  = barometric pressure – vapor pressure of H<sub>2</sub>O at body temperature;  $Vb$  = blood volume;  $P_{\text{Ico}}$  = partial pressure of CO in inhaled air;  $\dot{V}_A$  = alveolar ventilation;  $t$  = exposure duration

**Supplemental Figure 10. Coburn-Forster-Kane (CFK) equation.**

**Supplemental Table 1. Site of Infection and Microbiology Results**

Subject	Treatment	Site of infection	Microbiologic Data
<b>Cohort 1</b>			
Subject 1	CO	Lung/pleura	Negative
Subject 2	Air	Lung/pleura	BAL fluid and Sputum- <i>Pseudomonas</i>
Subject 3	CO	Lung/pleura	Sputum- <i>Klebsiella</i>
Subject 4	CO	Lung/pleura	Sputum- <i>S. aureus</i>
Subject 5	CO	Lung/pleura and GI/biliary tract	Blood- <i>Enterococcus</i> , <i>Candida</i>
Subject 6	Air	GI/biliary tract	Blood- <i>S. saccharolyticus</i>
<b>Cohort 2</b>			
Subject 7	Air	Lung/pleura	Sputum- <i>Serratia</i>
Subject 8	CO	Lung/pleura	Negative
Subject 9	CO	Lung/pleura	BAL fluid PCR- influenza
Subject 10	CO	Lung/pleura	BAL fluid, Tracheal aspirate, and Sputum- <i>S. aureus</i>
Subject 11	Air	Lung/pleura	Negative
Subject 12	CO	Skin/soft tissue	Negative

BAL, bronchoalveolar lavage

**Supplemental Table 2. Arterial Blood Gas Parameters Before and After Treatment**

Subject	Treatment	Study Day	Pre-treatment				Post-treatment			
			pH	PaCO <sub>2</sub>	PaO <sub>2</sub>	FiO <sub>2</sub>	pH	PaCO <sub>2</sub>	PaO <sub>2</sub>	FiO <sub>2</sub>
<b>Cohort 1</b>										
Subject 1	CO	Day 1	7.37	42	126	50	7.39	42	120	50
		Day 2	7.42	42	104	40	7.44	36	93	40
		Day 3	7.46	41	108	40	7.49	37	123	40
		Day 5	7.5	38	98	30	7.53	37	79	30
Subject 2	Air	Day 1	7.2	64	85	50	7.21	61	60	40
		Day 2	7.25	61	86	50	7.24	60	89	50
		Day 3	7.22	67	75	50	7.21	70	82	50
Subject 3	CO	Day 1	7.34	53	81	50	7.35	55	82	50
		Day 2	7.39	57	77	40	7.43	48	75	40
		Day 3	7.39	62	69	50	7.39	67	85	50
		Day 5	7.43	58	99	40	7.43	60	99	40
Subject 4	CO	Day 1	7.35	40	114	40	7.35	40	141	40
		Day 2	7.43	35	113	40	7.46	35	94	40
Subject 5	CO	Day 1	7.4	31	72	40	7.39	31	88	40
		Day 2	7.33	41	66	40	7.34	39	88	40
Subject 6	Air	Day 1	7.36	45	108	30	7.39	43	72	30
		Day 2	7.48	34	81	65	7.46	40	86	65
<b>Cohort 2</b>										
Subject 7	Air	Day 1	7.39	57	96	60	7.41	53	93	60
		Day 2	7.39	50	105	60	7.38	56	76	60
Subject 8	CO	Day 1	7.47	45	104	60	7.53	44	118	60
		Day 2	7.48	48	165	65	7.5	48	119	65
		Day 3	7.46	59	85	75	7.46	61	77	75
		Day 4	7.47	53	123	75	7.47	57	108	75
Subject 9	CO	Day 2	7.31	49	100	80	7.29	55	78	80
		Day 3	7.28	58	119	80	7.26	58	97	80
		Day 4	7.28	55	102	80	7.28	48	117	80
		Day 5	7.27	46	177	80	7.27	47	150	80
Subject 10	CO	Day 2	7.49	37	123	40	7.44	38	109	30
		Day 4	7.4	52	109	40	7.42	51	136	40
Subject 11	Air	Day 1	7.4	52	83	65	7.43	49	92	65
		Day 2	7.45	50	124	65	7.45	50	99	65
		Day 3	7.45	46	94	60	7.47	47	96	60
		Day 4	7.51	37	84	40	7.49	45	76	40
Subject 12	CO	Day 1	7.38	40	72	40	7.35	44	74	40
		Day 2	7.33	47	71	40	7.36	45	81	40
		Day 4	7.47	41	99	40	7.46	44	89	40

**Supplemental Table 3. Study Drug Holds Per Participant**

Subject	Treatment	Study Day	Reason For Study Drug Hold	Days Treated
<b>Cohort 1</b>				
Subject 1	CO	Day 4	Low hemoglobin as per protocol.	4
Subject 2	Air	Day 4	Patient went to the operating room for a procedure and was unable to be treated.	3
		Day 5	Low hemoglobin as per protocol.	
Subject 3	CO	Day 4	Pre-treatment EKG showed possible new ST elevations in leads V5 and V6. Cardiac enzymes were negative and not felt by clinical team to represent cardiac ischemia.	4
Subject 4	CO	Days 3, 4, and 5	Patient was no longer intubated.	2
Subject 5	CO	Days 3, 4, and 5	Arterial line fell out and was not replaced by the clinical team.	2
Subject 6	Air	Day 3	Severe hypoxemia as per protocol.	2
		Day 4	New hemodynamic instability.	
		Day 5	Arterial line not functioning, unable to monitor COHb levels.	
<b>Cohort 2</b>				
Subject 7	Air	Day 3	Arterial line fell out and was not replaced by the clinical team.	2
		Days 4 and 5	Patient was no longer intubated.	
Subject 8	CO	Day 5	Severe hypoxemia as per protocol.	4
Subject 9	CO	Day 1	Low hemoglobin as per protocol.	4
Subject 10	CO	Day 1	Low hemoglobin as per protocol.	2
		Day 3	Patient went to the operating room for a procedure and was unable to be treated.	
		Day 5	Baseline COHb level > 3%.	
Subject 11	Air	Day 5	Patient was going to be extubated that day.	4
Subject 12	CO	Day 3	Patient no longer had arterial line.	3
		Day 5	Patient was no longer intubated.	

COHb, carboxyhemoglobin; EKG, electrocardiogram.

**Supplemental Table 4. Cohort 1 Carboxyhemoglobin Levels**

Day	Time	N	Mean	SD	Median	Minimum	Maximum
<b>Cohort 1- CO group (n=4)</b>		<b>Carboxyhemoglobin Levels (%)</b>					
Day 1	Baseline	4	1.70	0.22	1.75	1.40	1.90
	20 min	4	2.26	0.33	2.22	1.90	2.70
	60 min	4	3.05	0.47	2.89	2.70	3.73
	75 min	4	3.22	0.57	3.04	2.80	4.00
	90 min	4	3.48	0.70	3.42	2.70	4.40
	180 min	4	3.23	0.30	3.19	2.90	3.63
	Δ 90 min	4	1.78	0.66	1.87	0.90	2.50
Day 2	Baseline	4	2.04	0.21	2.04	1.80	2.30
	20 min	4	2.53	0.13	2.50	2.40	2.70
	60 min	4	3.23	0.24	3.27	2.90	3.47
	75 min	4	3.28	0.86	3.67	2.00	3.80
	90 min	4	3.79	0.54	3.99	3.00	4.20
	180 min	4	3.49	0.02	3.50	3.47	3.50
	Δ 90 min	4	1.75	0.71	2.04	0.70	2.23
Day 3	Baseline	2	2.35	0.35	2.35	2.10	2.60
	20 min	2	2.84	0.23	2.84	2.67	3.00
	60 min	2	3.62	0.26	3.62	3.43	3.80
	75 min	2	3.94	0.37	3.94	3.67	4.20
	90 min	2	4.17	0.19	4.17	4.03	4.30
	180 min	2	3.67	0.47	3.67	3.33	4.00
	Δ 90 min	2	1.82	0.16	1.82	1.70	1.93
Day 5	Baseline	2	1.99	0.02	1.99	1.97	2.00
	20 min	2	2.77	0.37	2.77	2.50	3.03
	60 min	2	3.65	0.21	3.65	3.50	3.80
	75 min	2	3.82	0.12	3.82	3.73	3.90
	90 min	2	4.22	0.12	4.22	4.13	4.30
	180 min	2	3.82	0.12	3.82	3.73	3.90
	Δ 90 min	2	2.23	0.10	2.23	2.16	2.30
<b>Cohort 1- Placebo group (n=2)</b>		<b>Carboxyhemoglobin Levels (%)</b>					
Day 1	Baseline	2	1.80	0.28	1.80	1.60	2.00
	20 min	2	1.88	0.53	1.88	1.50	2.25
	60 min	2	1.78	0.25	1.78	1.60	1.95
	75 min	2	1.94	0.62	1.94	1.50	2.37
	90 min	2	1.78	0.53	1.78	1.40	2.15
	180 min	2	1.70	0.00	1.70	1.70	1.70
	Δ 90 min	2	-0.03	0.25	-0.03	-0.20	0.15
Day 2	Baseline	2	1.94	0.05	1.94	1.90	1.97
	20 min	2	1.84	0.09	1.84	1.77	1.90
	60 min	2	1.84	0.05	1.84	1.80	1.87
	75 min	2	2.07	0.09	2.07	2.00	2.13
	90 min	2	1.99	0.02	1.99	1.97	2.00
	180 min	2	1.89	0.12	1.89	1.80	1.97
	Δ 90 min	2	0.05	0.07	0.05	0.00	0.10
Day 3	Baseline	1	2.00	–	2.00	2.00	2.00
	20 min	1	1.80	–	1.80	1.80	1.80
	60 min	1	1.90	–	1.90	1.90	1.90
	75 min	1	2.00	–	2.00	2.00	2.00
	90 min	1	1.90	–	1.90	1.90	1.90
	180 min	1	1.90	–	1.90	1.90	1.90
	Δ 90 min	1	-0.10	–	-0.10	-0.10	-0.10

Δ 90 min, Change in carboxyhemoglobin level from baseline to 90 minutes at completion of treatment.



**Supplemental Table 5. Cohort 2 Carboxyhemoglobin Levels**

Day	Time	N	Mean	SD	Median	Minimum	Maximum
<b>Cohort 2- CO group (n=4)</b>		<b>Carboxyhemoglobin Levels (%)</b>					
Day 1	Baseline	2	1.64	0.19	1.64	1.50	1.77
	20 min	2	2.55	0.21	2.55	2.40	2.70
	60 min	2	3.87	0.05	3.87	3.83	3.90
	75 min	2	4.52	0.12	4.52	4.43	4.60
	90 min	2	4.90	0.28	4.90	4.70	5.10
	180 min	2	4.34	0.23	4.34	4.17	4.50
	Δ 90 min	2	3.27	0.47	3.27	2.93	3.60
Day 2	Baseline	4	2.06	0.62	1.92	1.50	2.90
	20 min	4	2.97	0.78	2.74	2.30	4.10
	60 min	4	4.34	0.96	4.09	3.50	5.70
	75 min	4	4.85	1.07	4.59	3.90	6.33
	90 min	4	5.36	1.11	5.09	4.40	6.87
	180 min	3	4.51	1.37	3.97	3.50	6.07
	Δ 90 min	4	3.30	0.69	3.35	2.54	3.97
Day 3	Baseline	2	1.85	0.35	1.85	1.60	2.10
	20 min	2	2.49	0.40	2.49	2.20	2.77
	60 min	2	3.70	0.28	3.70	3.50	3.90
	75 min	2	4.09	0.26	4.09	3.90	4.27
	90 min	2	4.45	0.21	4.45	4.30	4.60
	180 min	2	3.75	0.21	3.75	3.60	3.90
	Δ 90 min	2	2.60	0.14	2.60	2.50	2.70
Day 4	Baseline	4	2.04	0.55	1.97	1.50	2.73
	20 min	4	2.82	0.57	2.67	2.30	3.63
	60 min	4	4.33	0.65	4.20	3.70	5.20
	75 min	4	4.88	0.80	4.75	4.10	5.90
	90 min	4	5.18	0.79	5.17	4.40	6.00
	180 min	4	4.28	1.01	4.27	3.10	5.47
	Δ 90 min	4	3.14	0.67	3.09	2.40	4.00
Day 5	Baseline	2	2.19	1.53	2.19	1.10	3.27
	20 min	1	2.30	–	2.30	2.30	2.30
	60 min	1	4.10	–	4.10	4.10	4.10
	75 min	1	4.60	–	4.60	4.60	4.60
	90 min	1	5.00	–	5.00	5.00	5.00
	180 min	1	3.00	–	3.00	3.00	3.00
	Δ 90 min	1	3.90	–	3.90	3.90	3.90
<b>Cohort 2- Placebo group (n=2)</b>		<b>Carboxyhemoglobin Levels (%)</b>					
Day 1	Baseline	2	2.07	0.09	2.07	2.00	2.13
	20 min	2	2.15	0.21	2.15	2.00	2.30
	60 min	2	2.29	0.37	2.29	2.03	2.55
	75 min	2	2.07	0.09	2.07	2.00	2.13
	90 min	2	2.17	0.19	2.17	2.03	2.30
	180 min	2	2.27	0.09	2.27	2.20	2.33
	Δ 90 min	2	0.10	0.10	0.10	0.03	0.17
Day 2	Baseline	2	2.34	0.47	2.34	2.00	2.67
	20 min	2	2.34	0.37	2.34	2.07	2.60
	60 min	2	2.45	0.31	2.45	2.23	2.67
	75 min	2	2.32	0.16	2.32	2.20	2.43
	90 min	2	2.32	0.26	2.32	2.13	2.50
	180 min	2	2.29	0.45	2.29	1.97	2.60
	Δ 90 min	2	-0.02	0.21	-0.02	-0.17	0.13
Day 3	Baseline	1	2.03	–	2.03	2.03	2.03
	20 min	1	2.00	–	2.00	2.00	2.00
	60 min	1	2.03	–	2.03	2.03	2.03
	75 min	1	2.13	–	2.13	2.13	2.13
	90 min	1	2.13	–	2.13	2.13	2.13
	180 min	1	1.97	–	1.97	1.97	1.97
	Δ 90 min	1	0.10	–	0.10	0.10	0.10
Day 4	Baseline	1	2.20	–	2.20	2.20	2.20
	20 min	1	2.10	–	2.10	2.10	2.10
	60 min	1	2.03	–	2.03	2.03	2.03
	75 min	1	2.07	–	2.07	2.07	2.07
	90 min	1	2.10	–	2.10	2.10	2.10
	180 min	1	2.07	–	2.07	2.07	2.07
	Δ 90 min	1	-0.10	–	-0.10	-0.10	-0.10

Δ 90 min, Change in carboxyhemoglobin level from baseline to 90 minutes at completion of treatment.

**Supplemental Table 6. Comparison of Carboxyhemoglobin Levels Between Groups**

	Baseline	20 min	60 min	75 min	90 min	180 min
<b>Day 1 COHb</b>						
100 ppm vs. placebo	NS	NS	p=0.0017	p=0.0002	p<0.0001	p=0.0001
200 ppm vs. placebo	NS	NS	p<0.0001	p<0.0001	p<0.0001	p<0.0001
100 ppm vs. 200 ppm	NS	NS	p=0.0501	p=0.0011	p=0.0004	p=0.0054
<b>Day 2 COHb</b>						
100 ppm vs. placebo	NS	NS	p=0.0515	p=0.0489	p=0.0018	p=0.0081
200 ppm vs. placebo	NS	NS	p<0.0001	p<0.0001	p<0.0001	p<0.0001
100 ppm vs. 200 ppm	NS	NS	p=0.0429	p=0.0029	p=0.0029	p=0.0556
<b>Day 3 COHb</b>						
100 ppm vs. placebo	NS	p=0.0060	p<0.0001	p<0.0001	p<0.0001	p<0.0001
200 ppm vs. placebo	NS	NS	p<0.0001	p<0.0001	p<0.0001	p<0.0001
100 ppm vs. 200 ppm	NS	NS	NS	NS	NS	NS

COHb, carboxyhemoglobin.

Statistical significance was determined by two-way ANOVA followed by Tukey's post-tests. Adjusted p values are shown between groups. Statistical testing could not be performed on days 4 and 5 due to insufficient n.

**Supplemental Table 7. Baseline and Day 2 Post-Treatment Mitochondrial DNA Levels**

Subject	Treatment	Pre-treatment mtDNA level, Day 1 (copies/ $\mu$ L)	Post-treatment mtDNA level, Day 2 (copies/ $\mu$ L)
<b>Cohort 1</b>			
Subject 1	CO	907	1179
Subject 2	Air	18280	53698
Subject 3	CO	11048	17770
Subject 4	CO	4496	2701
Subject 5	CO	37055	45391
Subject 6	Air	6813	13554
<b>Cohort 2</b>			
Subject 7	Air	1745	21700
Subject 8	CO	9371	1622
Subject 9*	CO	**	695
Subject 10*	CO	1016	443
Subject 11	Air	2034	7382
Subject 12	CO	4281	404

\* Study hold on day 1, not included in analysis. \*\* Baseline level not available.

**Supplemental Table 8. Luminex Biomarker Panel**

Analyte
sCD40L
EGF
Eotaxin/CCL11
FGF-2
Fit-3 ligand
Fractalkine
G-CSF
GM-CSF
GRO
IFN- $\alpha$ 2
IFN- $\gamma$
IL-1 $\alpha$
IL-1 $\beta$
IL-1ra
IL-2
IL-3
IL-4
IL-5
IL-6
IL-7
IL-8
IL-9
IL-10
IL-12 (p40)
IL-12 (p70)
IL-13
IL-15
IL-17A
IP-10
MCP-1
MCP-3
MDC (CCL22)
MIP-1 $\alpha$
MIP-1 $\beta$
PDGF-AA
PDGF-AB/BB
RANTES
TGF- $\alpha$
TNF- $\alpha$
TNF- $\beta$
VEGF

## Supplemental Table 9. Inclusion and Exclusion Criteria

### Inclusion Criteria

- **Adults above the age of 18**
- **Sepsis**
  1. Suspected or proven infection
  2. SOFA  $\geq$  2
- **ARDS**
  1. PaO<sub>2</sub>/FiO<sub>2</sub> ratio  $\leq$  300 with at least 5 cm H<sub>2</sub>O PEEP
  2. Bilateral infiltrates consistent with pulmonary edema on chest X-ray
  3. A need for positive pressure ventilation
  4. No evidence of left atrial hypertension for bilateral infiltrates

### Exclusion Criteria

1. Age less than 18 years
2. Greater than 120 hours since ARDS onset
3. Pregnant or breastfeeding
4. Prisoner
5. Patient, surrogate, or physician not committed to full support (exception: a patient will not be excluded if he/she would receive all supportive care except for attempts at resuscitation from cardiac arrest)
6. No consent/inability to obtain consent
7. Physician refusal to allow enrollment in the trial
8. Moribund patient not expected to survive 24 hours
9. No arterial line/no intent to place an arterial line
10. No intent/unwillingness to follow lung protective ventilation strategy
11. Severe hypoxemia defined as SpO<sub>2</sub> < 95 or PaO<sub>2</sub> < 80 on FiO<sub>2</sub>  $\geq$  0.8
12. Hemoglobin < 7.5 g/dl or hemoglobin < 8 g/dl and actively bleeding
13. Subjects who are Jehovah's Witnesses or are otherwise unable or unwilling to receive blood transfusions during hospitalization
14. Acute myocardial infarction or acute coronary syndrome within 90 days
15. Coronary artery bypass graft (CABG) surgery within 30 days
16. Angina pectoris or use of nitrates with activities of daily living
17. Cardiopulmonary disease classified as NYHA class IV
18. Stroke (ischemic or hemorrhagic) within the prior 3 months
19. Diffuse alveolar hemorrhage from vasculitis
20. Use of high frequency ventilation
21. Participation in other interventional studies involving investigational agents
22. Burns > 40% total body surface area
23. Use of inhaled pulmonary vasodilator therapy (eg. NO or prostaglandins)

CABG, coronary artery bypass graft; NO, nitric oxide; NYHA, New York Heart Association; PEEP, positive end-expiratory pressure; SOFA, Sequential Organ Failure Assessment; SpO<sub>2</sub>, oxygen saturation by pulse oximetry.

**Supplemental Table 10. Pre-specified Administration-associated Adverse Events (AEs)**

- Acute myocardial infarction within 48 hours of study drug administration
- Acute cerebrovascular accident (CVA) within 48 hours of study drug administration
- New onset atrial or ventricular arrhythmia requiring DC cardioversion within 48 hours of study drug administration
- Increased oxygenation requirements defined as: an increase in  $\text{FiO}_2$  of  $\geq 0.2$  AND increase in PEEP  $\geq 5$  cm  $\text{H}_2\text{O}$  within 6 hours of study drug administration
- Increase in any protocol-specified measurement of COHb to  $\geq 10\%$
- Increase in lactate by  $\geq 2$  mmol/L within 6 hours of study drug administration

AE, adverse event; COHb, carboxyhemoglobin; CVA, cerebrovascular accident; DC, direct current; PEEP, positive end-expiratory pressure.

**A Phase I Trial of Inhaled Carbon Monoxide for the Treatment  
of Sepsis-Induced Acute Respiratory Distress Syndrome (ARDS)**

**Protocol Version 12  
December 5, 2017  
IND 122800**

**Sponsor: Mark A. Perrella, M.D.**

## TABLE OF CONTENTS

<b>ABBREVIATIONS</b> .....	<b>5</b>
<b>DEFINITIONS</b> .....	<b>7</b>
<b>PART I: STUDY SUMMARY</b> .....	<b>9</b>
<b>PART II: STUDY DESCRIPTION</b> .....	<b>12</b>
<b>1. BACKGROUND</b> .....	<b>12</b>
1.1. INTRODUCTION.....	12
1.2. BIOLOGICAL PROPERTIES OF CO.....	12
1.3. CO AND ANIMAL MODELS OF SEPSIS AND ALI.....	12
1.4. LUNG PROTECTIVE EFFECTS OF CO.....	14
1.5. CO DELIVERY VIA AN INHALED ROUTE IS SAFE IN HUMAN SUBJECTS.....	14
1.6. STEADY STATE DIFFUSING CAPACITY AND THE SAFETY OF INHALED CO.....	16
1.7. DELIVERY OF INHALED CO TO MECHANICALLY VENTILATED SUBJECTS.....	16
1.8. CO DELIVERY SYSTEM TESTING IN BABOON MODEL OF PNEUMONIA.....	17
1.9. CO DOSING STRATEGY USING CFK EQUATION.....	19
1.11. STUDY RATIONALE.....	20
<b>2. OBJECTIVES AND STUDY DESIGN</b> .....	<b>21</b>
2.1. STUDY OBJECTIVE.....	21
2.2. HYPOTHESES.....	21
2.3. STUDY DESIGN.....	21
2.4. ACCRUAL OBJECTIVE.....	21
2.5. STUDY PRODUCT, DOSE, ROUTE, AND REGIMEN.....	22
<b>3. ENDPOINTS</b> .....	<b>23</b>
3.1. PRIMARY ENDPOINT.....	23
3.2. SECONDARY ENDPOINT.....	23
3.3. OTHER SECONDARY ENDPOINTS.....	23
3.4. FOCUSED SAFETY ANALYSIS.....	23
<b>4. STUDY POPULATION AND ENROLLMENT</b> .....	<b>23</b>
4.1. SCREENING.....	23
4.2. INCLUSION CRITERIA.....	24
4.3. EXCLUSION CRITERIA.....	24
4.4. ENROLLMENT, RANDOMIZATION AND STUDY INITIATION TIME WINDOW.....	25



# A Phase I Trial of Inhaled Carbon Monoxide for the Treatment of Sepsis-Induced ARDS

4.5. INFORMED CONSENT.....	26
4.6. ENROLLMENT AND RANDOMIZATION .....	26
<b>5. STUDY PROCEDURES .....</b>	<b>27</b>
5.1 CO OR PLACEBO STUDY PROCEDURES .....	27
5.2. VENTILATOR PROCEDURES.....	32
<b>6. DATA COLLECTION.....</b>	<b>33</b>
6.1. BACKGROUND ASSESSMENTS .....	33
6.2. BASELINE ASSESSMENTS.....	33
6.3. ASSESSMENTS AFTER ENROLLMENT .....	34
6.4. ASSESSMENTS AFTER HOSPITALIZATION.....	38
6.5. ENDPOINT DETERMINATIONS.....	39
<b>7. STATISTICAL CONSIDERATIONS AND SAFETY ASSESSMENT .....</b>	<b>39</b>
7.1. STATISTICAL CONSIDERATIONS .....	39
7.2. PHASE I SAFETY ASSESSMENT .....	40
7.3. SUMMARY GUIDELINES FOR SRC AND DSMB ASSESSMENT.....	40
<b>8. DATA COLLECTION AND SITE MONITORING.....</b>	<b>41</b>
8.1. DATA COLLECTION.....	41
8.2. SITE MONITORING.....	41
<b>9. RISK ASSESSMENT .....</b>	<b>41</b>
9.1. RISKS OF ACTIVE STUDY DRUG .....	41
9.2. RISKS OF BLOOD DRAWS .....	41
9.3. MINIMIZATION OF RISKS.....	41
9.4. POTENTIAL BENEFITS .....	42
9.5. RISKS VERSUS BENEFITS.....	42
<b>10. HUMAN SUBJECTS.....</b>	<b>42</b>
10.1. SELECTION OF SUBJECTS .....	43
10.2. INFORMED CONSENT.....	43
10.3. CONTINUING CONSENT .....	43
10.4. IDENTIFICATION OF SURROGATES.....	43
10.5. JUSTIFICATION OF SURROGATE CONSENT .....	44
10.6. ADDITIONAL SAFEGUARDS FOR VULNERABLE SUBJECTS .....	44
10.7. CONFIDENTIALITY .....	45

**11. ADVERSE EVENT REPORTING ..... 45**

**12. REFERENCES..... 47**

**13. APPENDICES .....53**

**APPENDIX A: GUIDELINES FOR EVIDENCE OF INFECTION ..... 53**

**APPENDIX B: CFK EQUATION AND PREDICTED COHB CURVES IN HUMANS ..... 55**

**APPENDIX C: PREDICTED COHB LEVELS IN ARDS USING CFK EQUATION ..... 58**

**APPENDIX D: DE-IDENTIFIED DATA FOR SCREENED, NON-ENROLLED SUBJECTS ..... 59**

**APPENDIX E: AMBIENT CO TESTING ..... 60**

**APPENDIX F: TIME-EVENTS SCHEDULE ..... 86**

**APPENDIX G: VENTILATOR PROCEDURES ..... 87**

**APPENDIX H: DEAD SPACE MEASUREMENT ..... 90**

**APPENDIX I: GENETIC TESTING ..... 93**

**APPENDIX J: DATA AND SAFETY MONITORING BOARD ..... 94**

**APPENDIX K: ADVERSE EVENTS ..... 95**

**APPENDIX L: IL682 CO-OXIMETER PROCEDURE ..... 96**

**APPENDIX M: NEUROCOGNITIVE DATA- CO AND IPF ..... 105**

**APPENDIX N: LINDE CSR - SAFETY AND TOLERABILITY OF INHALED CO ..... 106**

**APPENDIX O: CO DELIVERY SYSTEM OPERATOR’S MANUAL ..... 341**

**APPENDIX P: CO DELIVERY SYSTEM TECHNICAL INFORMATION ..... 368**

## ABBREVIATIONS

**ABG** = arterial blood gas  
**ALI** = Acute Lung Injury  
**Ang-2** = Angiopoietin-2  
**ARDS** = Acute Respiratory Distress Syndrome  
**BAL** = Bronchoalveolar Lavage  
**BMI** = Body Mass Index  
**BUN** = Blood Urea Nitrogen  
**BWH** = Brigham and Women's Hospital  
**CO** = carbon monoxide  
**COHb** = carboxyhemoglobin  
**CHF** = Congestive Heart Failure  
**CFK equation** = Coburn-Foster-Kane equation  
**CPAP** = Continuous Positive Airway Pressure  
**CPR** = Cardiopulmonary resuscitation  
**CT** = Computed Tomography  
**DCC** = Data Coordinating Center  
**DBP** = Diastolic Blood Pressure  
**DLCO** = Diffusing capacity for carbon monoxide  
**DSMB** = Data Safety Monitoring Board  
**FiO<sub>2</sub>** = Fraction of Inspired Oxygen  
**GCS** = Glasgow Coma Scale  
**iCO** = inhaled carbon monoxide  
**ICU** = Intensive Care Unit  
**IL-1 $\beta$**  = Interleukin 1 $\beta$   
**IL-1Ra** = IL-1 receptor antagonist  
**IL-6** = Interleukin 6  
**IL-8** = Interleukin 8  
**IL-10** = Interleukin 10  
**IL-18** = Interleukin 18  
**IMV** = Intermittent Mechanical Ventilation  
**INR** = International Normalized Ratio  
**mBW** = measured body weight  
**MGH** = Massachusetts General Hospital  
**NO** = nitric oxide  
**OR** = Odds Ratio  
**PaCO<sub>2</sub>** = Partial pressure of arterial carbon dioxide  
**PaO<sub>2</sub>** = Partial pressure of arterial oxygen  
**PAP** = Pulmonary Artery Pressure

## A Phase I Trial of Inhaled Carbon Monoxide for the Treatment of Sepsis-Induced ARDS

**PB** = Barometric Pressure

**PBW** = Predicted Body Weight

**PEEP** = Positive End-Expiratory Pressure

**Pplat** = Plateau pressure

**ppm** = parts per million

**PS** = Pressure Support Ventilation

**Receptor for Advanced Glycation Endproducts** = RAGE

**SRC** = Scientific Review Committee

**SBP** = Systolic Blood Pressure

**SBT** = Spontaneous Breathing Trial

**Sequential Organ Failure Assessment**= SOFA

**SpO<sub>2</sub>** = Oxygen Saturation

**SpCO** = Non-invasive COHb by pulse oximetry

**VFD** = Ventilator-free Days

**V<sub>A</sub>** = Alveolar ventilation

**Vd/Vt** = Dead space

**von Willebrand factor** = vWF

**WBC** = White Blood Cell

## DEFINITIONS

**Acute Kidney Injury:** Acute kidney injury network Stage 3 disease, defined as a threefold increase in creatinine from baseline or the need for dialysis

**Completing 48 hours of UAB (from weaning form):** Defined as the date (calendar day) that the subject reaches exactly 48 hours of UAB. Example: if subject meets UAB at 1900 on 6/1/06 and does not return to AB, then the date of completing 48 hours of UAB would be 6/3/06.

**Date of first UAB (from Study Termination form):** Defined as the first day that the subject is on UAB from midnight to midnight. Example: if subject meets UAB at 1900 on 6/1/06, then the date of first UAB would be 6/2/06, as long as subject does not return to AB on 6/2/06.

**Day zero:** Defined as day of randomization.

**Drug held/hold drug:** Study medication withheld for 24 hours.

**Drug permanently discontinued:** Study medication stopped for remainder of the trial.

**Extubation:** Removal of an orotracheal, nasotracheal tube, or unassisted breathing with a tracheostomy.

**Home:** level of residence or health care facility where the patient was residing prior to hospital admission

**Hospital Mortality to Day 60:** This primary endpoint includes all deaths following randomization in any health care facility prior to discharge “home” until study day 60. Study subjects still in a health care facility at study day 61 are considered alive for this endpoint.

**Interruption of Dosing During Drug Administration:** Study medication prematurely stopped prior to 90 minutes.

**NYHA:** New York Heart Association Class IV subjects (defined as subjects who have cardiac disease resulting in inability to carry out physical activity without discomfort. Symptoms of cardiac insufficiency or an anginal syndrome may be present even at rest. If any physical activity is undertaken, discomfort is increased).

**Sepsis:** Suspected or known infection.

**Study Drug:** Defined as inhaled carbon monoxide at 100 ppm, 200 ppm, or dosing algorithm-specified dose, or placebo.

**Study hospital:** Defined as the hospital where the patient was enrolled.

**Study withdrawal:** Defined as permanent withdrawal from study before completion of study activities. This does not include those subjects who have completed the protocol procedures or stopped procedures because they have reached unassisted breathing. If a patient or surrogate requests withdrawal from the study, the investigators will seek explicit permission to continue data collection.

**UAB (Unassisted Breathing):** Spontaneously breathing with face mask, nasal prong oxygen, or room air, T-tube breathing, tracheostomy mask breathing, or CPAP  $\leq 5$  without PS or IMV assistance, or the use of noninvasive ventilation solely for sleep-disordered breathing. Assisted breathing is any level of ventilator support at pressures higher than the unassisted breathing.

## Part I: Study Summary

**Title:** A Phase I Trial of Inhaled Carbon Monoxide for the Treatment of Sepsis-Induced Acute Respiratory Distress Syndrome (ARDS)

**Objective:** To assess the safety of inhaled carbon monoxide (iCO) in intubated patients with sepsis-induced ARDS.

### Hypotheses:

- Administration of inhaled CO therapy will be safe in intubated patients with sepsis-induced ARDS.
- CO dosing approach will be safe and effective in determining patient-specific CO dose to achieve a target COHb of 6-8% (Cohort 3).

### Study Design:

1. Multi-center, prospective, randomized, placebo-controlled Phase 1 clinical trial of inhaled CO for the treatment of sepsis-induced ARDS.
2. In Cohorts 1 and 2, intubated patients will be randomized to receive inhaled CO or inhaled air placebo for up to 90 minutes daily.
3. In Cohort 3, intubated patients will receive open label inhaled CO for up to 90 minutes daily.
4. Treatment will continue for 5 days, until discontinuation of mechanical ventilation, or death, whichever comes first.
5. In Cohort 1, patients will be randomized to iCO at 100 ppm or placebo (2:1 ratio).
6. In Cohort 2, patients will be randomized to iCO at 200 ppm or placebo (2:1 ratio).
7. In Cohort 3, patients will receive open label algorithm-specified iCO dose (not to exceed 500 ppm) to achieve COHb of 6-8%.
8. Patients will be followed for 60 days or until discharge from the hospital to home with unassisted breathing, whichever occurs first.

### Sample Size/Interim Monitoring:

1. A total of 36 patients will be enrolled to achieve dosing of 18 subjects meeting protocol defined criteria for cohort completers. Enrollment goal for cohort completers will be as follows: Cohort 1- 6 subjects (2:1 CO:placebo); Cohort 2- 6 subjects (2:1 CO:placebo); Cohort 3- 6 subjects open label CO.
2. The primary analysis will be safety.
3. Trial progress will be monitored after each cohort by an independent Data and Safety Monitoring Board to determine if the study should proceed to the next cohort. The DSMB will also monitor trial quality and feasibility approximately every 6 months and will be available as needed on *ad hoc* basis.

**Inclusion Criteria:** Patients with ARDS from sepsis will be enrolled as defined below.

- Patients with sepsis are defined as those with suspected or documented infection:
  - Suspected or proven infection: Sites of infection include thorax, urinary tract, abdomen, skin, sinuses, central venous catheters, and central nervous system (**Appendix A**).

## A Phase I Trial of Inhaled Carbon Monoxide for the Treatment of Sepsis-Induced ARDS

All eligible patients meet the new definition of sepsis (suspected or proven infection and a SOFA  $\geq$  2) as  $\text{PaO}_2/\text{FiO}_2$  ratio  $< 300 = 2$  SOFA points<sup>1</sup>.

- ARDS is defined when all four of the following criteria are met:
  1. A  $\text{PaO}_2/\text{FiO}_2$  ratio  $\leq 300$  with at least 5 cm  $\text{H}_2\text{O}$  positive end-expiratory airway pressure (PEEP)
  2. Bilateral infiltrates consistent with pulmonary edema on frontal chest radiograph
  3. A need for positive pressure ventilation by an endotracheal or tracheal tube
  4. No clinical evidence of left atrial hypertension for bilateral pulmonary infiltrates.
- ARDS onset is defined as the time the last of criteria 1-4 are met. ARDS must persist through the enrollment time window of 120 hours.
- Infiltrates considered “consistent with pulmonary edema” include any infiltrates not fully explained by mass, atelectasis, or effusion or opacities known to be chronic (greater than 1 week). Vascular redistribution, indistinct vessels, and indistinct heart borders alone are not considered “consistent with pulmonary edema” and thus would not count as qualifying opacities for this study.

### **Exclusion Criteria:**

1. Age less than 18 years
2. Greater than 120 hours since ARDS onset
3. Pregnant or breast-feeding
4. Prisoner
5. Patient, surrogate, or physician not committed to full support (exception: a patient will not be excluded if he/she would receive all supportive care except for attempts at resuscitation from cardiac arrest)
6. No consent/inability to obtain consent
7. Physician refusal to allow enrollment in the trial
8. Moribund patient not expected to survive 24 hours
9. No arterial line/no intent to place an arterial line
10. No intent/unwillingness to follow lung protective ventilation strategy
11. Severe hypoxemia defined as  $\text{SpO}_2 < 95$  or  $\text{PaO}_2 < 80$  on  $\text{FiO}_2 \geq 0.8$
12. Hemoglobin  $< 7.5$  g/dl or hemoglobin  $< 8$  g/dl and actively bleeding
13. Subjects who are Jehovah’s Witnesses or are otherwise unable or unwilling to receive blood transfusions during hospitalization
14. Acute myocardial infarction (MI) or acute coronary syndrome (ACS) within the last 90 days
15. Coronary artery bypass graft (CABG) surgery within 30 days
16. Angina pectoris or use of nitrates with activities of daily living
17. Cardiopulmonary disease classified as NYHA class IV
18. Stroke (ischemic or hemorrhagic) within the prior 3 months
19. Diffuse alveolar hemorrhage from vasculitis
20. Use of high frequency ventilation
21. Participation in other interventional studies involving investigational agents



## A Phase I Trial of Inhaled Carbon Monoxide for the Treatment of Sepsis-Induced ARDS

22. Burns > 40% total body surface area

23. Use of inhaled pulmonary vasodilator therapy (eg. NO or prostaglandins)

**Endpoint:** The primary endpoint is safety of inhaled CO, defined by the incidence of pre-specified administration-associated adverse events and severe adverse events, in sepsis-induced ARDS patients.

**Secondary Endpoint:** The secondary endpoint is determination of the accuracy of the inhaled CO dosing approach in intubated patients with sepsis-induced ARDS.

### **Other Secondary Endpoints:**

1. Mean daily Sequential Organ Failure Assessment (SOFA) score
2. PaO<sub>2</sub>/FiO<sub>2</sub> ratio and Oxygenation Index
3. Lung injury score
4. Vasopressor-free days
5. Ventilator-free days
6. ICU-free days at day 28
7. Hospital-free days at day 60
8. Hospital mortality to day 28 and 60
9. Plasma biomarkers of inflammation (IL-6, IL-8, IL-10, IL-1Ra, IL-18, IL1 $\beta$ , and circulating mitochondrial DNA), lung epithelial injury (RAGE), endothelial injury (vWF, Ang-2), markers of change in other end-organ function (e.g., creatinine, liver function tests, lactate)

**Focused Safety Analysis:** The incidence of elevation in plasma COHb  $\geq$  10% measured on study days 1-5 and pre-specified administration-associated adverse events and serious adverse events.

**Study Drug Dosing:** All study drug doses will be administered via inhalation using a mechanical ventilator approved for nitric oxide (NO) delivery and the CO Delivery System. The study drug will be blinded to the study coordinator using identical tanks containing either CO or placebo air. The administering respiratory therapist and a physician study staff member will be unblinded to the treatment assignments.

**Completion of study drug administration:** Study drug administration will be stopped when one of the following conditions is met, whichever comes first:

1. Completion of the fifth dose of study drug
2. Discontinuation of mechanical ventilation
3. Death
4. Pre-specified criteria met for permanent discontinuation of study drug (**Section 5.1.9**)

## Part II: Study Description

### A Phase I Trial of Inhaled Carbon Monoxide for the Treatment of Sepsis-Induced Acute Respiratory Distress Syndrome (ARDS)

#### 1. Background

##### 1.1. Introduction

The acute respiratory distress syndrome (ARDS) is a syndrome of severe acute lung inflammation and hypoxemic respiratory failure with an incidence of 180,000 cases annually in the U.S.<sup>2,3</sup>. Despite decades of research and recent advances in lung protective ventilator strategies<sup>4</sup>, morbidity and mortality remain unacceptably high. Furthermore, no specific effective pharmacologic therapies currently exist. Sepsis, a clinical syndrome manifested by a systemic inflammatory response to an underlying infection, represents a major risk for the development of ARDS and multi-organ dysfunction syndrome (MODS). In recent years, the number of patients with severe sepsis has risen to 750,000 per year in the U.S.<sup>5-7</sup>, which bears an alarming forecast for critically ill patients in the intensive care unit with significant risk for the development of ARDS. The lack of specific effective therapies for sepsis-related ARDS indicates a need for new treatments that target novel pathways. Carbon monoxide (CO) represents a novel therapeutic modality in ARDS based on data obtained in experimental models of ARDS and sepsis over the past decade.

##### 1.2. CO is an endogenously produced gaseous molecule with pleiotropic biological functions

CO is made in the body by heme oxygenase-1 (HO-1), one of the few inducible molecules that can protect the lungs from an increased oxidant burden under circumstances of stress<sup>8</sup>. HO-1 is ubiquitously expressed, and is responsible for degradation of heme to biliverdin, free iron, and CO. While all three products of its activity have been shown to possess cytoprotective properties, CO is the product that has been most extensively studied with respect to lung disease. This colorless, odorless diatomic gas has been shown in the past to exert biological functions as diverse as protection against oxidative injury<sup>9-11</sup>, inflammation<sup>12</sup>, and cell death<sup>13,14</sup>, inhibition of cell proliferation<sup>15</sup>, suppression of matrix production<sup>16</sup>, increased fibrinolysis<sup>17</sup>, as well as enhanced phagocytosis<sup>18,19</sup> and macrophage efferocytosis<sup>20</sup>, all of which may be important in the pathogenesis of sepsis and ARDS. Recently, we have demonstrated several mechanisms by which CO exerts these beneficial effects including activation of mitochondrial biogenesis<sup>21</sup>, enhancement of autophagy<sup>19</sup>, and acceleration of resolution of inflammation via biosynthesis of specialized proresolving mediators<sup>20</sup>.

##### 1.3. Administration of inhaled CO protects against endotoxemia and lung injury in animal models

Our laboratory has a long history of studying experimental ALI using animal models, including hyperoxia and endotoxin exposure, bleomycin, ischemia/reperfusion, and ventilator-induced lung injury (VILI). Our published studies have indicated that application of CO at low concentration can confer tissue protective effects in these ALI models<sup>10,11,16,22-27</sup>. In addition, we and others have demonstrated that CO decreases inflammation, enhances phagocytosis, and improves mortality in models of sepsis including endotoxemia<sup>12,28,29</sup>, hemorrhagic shock<sup>30</sup> and cecal ligation and puncture (CLP)<sup>18,19</sup>. In addition, CO has been shown to have beneficial therapeutic effects in pre-clinical models of disease including pulmonary hypertension<sup>31-34</sup>, vascular injury<sup>35-39</sup>, and transplantation<sup>25,26,40-48</sup> (**Table 1**).

**Table 1: Pre-clinical studies using inhaled CO**

Model	Year	Species	CO (ppm)	Outcome	Reference
Lung injury (VILI, acid, hyperoxia, LPS)	1999, 2003, 2004, 2008, 2009, 2010	mouse, rat, macaques	10-250, 500	Less inflammation & lung injury	10,11,22-24,49
Bleomycin lung fibrosis	2005	mouse	250	Decreased lung hydroxyproline, fibronectin, collagen	16
Ischemia-reperfusion (hind leg, lung)	2001, 2003, 2006, 2007, 2009	mouse, rat	250, 500, 1000	Less remote organ inflammation, less apoptosis, improved survival	14,17,27,50-52
Transplantation (liver, lung, kidney, heart, intestine)	2001, 2003, 2004, 2006, 2007, 2008, 2009	mouse, rat	20, 250, 400, 500	Improved survival & graft function, less inflammation & apoptosis	25,26,40-43,45-48,53
Endotoxemia	2000, 2003, 2004	rat, mouse	10-250	Improved survival, decreased inflammation	12,28,29
Hemorrhagic shock	2005	mouse	250	Decreased end organ injury/ischemia	30
Cecal ligation and puncture	2008, 2014	mouse	250	Improved survival, decreased inflammation, enhanced phagocytosis	18,19
Pulmonary arterial hypertension	2006	rat, mouse	50, 250	Reversal of established PAH & reversal of remodeling	31
Vascular injury	2003, 2005, 2006, 2007	mouse, pig	100, 250-500	less intimal hyperplasia, reduced thrombosis	35-39
Cardiopulmonary bypass	2004, 2008, 2009	pig	250	Less lung injury, decreased cardiac edema, apoptosis	54-57
Doxorubicin cardiomyopathy	2007	mouse	500	Improved cardiac function	58,59
Asthma	2003	mouse	250-1000	Reduced inflammation & bronchoconstriction	16,60,61
Cerebral malaria	2007	mouse	250	Reduced incidence of cerebral malaria	62
Hepatitis	2003, 2007	mouse	100, 250, 500	Improved survival, decreased apoptosis	63,64
Colitis, ileus	2005	mouse, rat, pig	250	Reduced injury & inflammation, improved motility	31,65-67

Sickle cell disease	2009	mouse	250	Reduced leukocytosis	68
Collagen-induced arthritis	2009	mouse	200	Improved arthritis score, less inflammation	69
Ureteral obstruction	2008	mouse	250	Reduced renal fibrosis	70

### 1.4. Lung protective effects of carbon monoxide

Numerous studies have examined the protective effects of low concentrations of carbon monoxide on the pulmonary parenchyma and vasculature. Inhaled CO prolongs survival and prevents tissue injury and epithelial cell death in rodents subjected to high oxygen stress<sup>10</sup>. CO also reduces lung cell apoptosis during lung ischemia-reperfusion injury in mice<sup>27</sup> and prevents tissue injury during mechanical ventilation in mice by preventing alveolar-capillary barrier dysfunction and reducing inflammation<sup>22-24</sup>. Low concentration inhaled CO can also reverse established pulmonary hypertension in rats<sup>31</sup> and has been shown to protect against endothelial apoptosis<sup>13</sup>. In addition, CO has been shown to de-repress fibrinolysis and to inhibit expression of plasminogen activator inhibitor-1, which could alter the progression of fibrosis<sup>17</sup>. CO has also been shown to confer protection in a number of additional disease models, including asthma, vascular injury, transplantation and fibrosis (**Table 1**). These studies collectively have provided a rationale for pursuing the clinical applications of CO, including the trials outlined below.

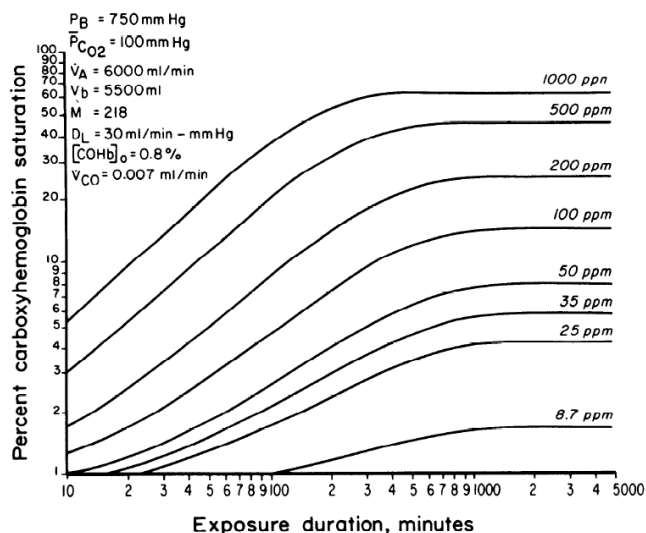

### 1.5. CO delivery via an inhaled route is safe in human subjects

Carbon monoxide has proven to be an ideal gas for developing theoretical uptake equations. The formation of carboxyhemoglobin (COHb) on the basis of CO exposure is well described by a physiologically based pharmacokinetics model developed by Coburn in 1965 and is referred to as the Coburn-Foster-Kane equation (typically identified as the CFK or CFKE) in the literature<sup>71</sup>. This model has been tested and confirmed in humans for varying inspired CO levels and durations of exposure<sup>72-78</sup> (**Figure 1**).

**Figure 1. COHb levels as a function of exposure duration and CO concentration as determined by the CFK equation. (Peterson et al., 1975)**

Extensive data is available regarding the safety and tolerability of low dose inhaled CO in healthy volunteers<sup>76,79-84</sup> and more recently, in subjects with COPD<sup>85</sup> (**Table 2**). Previous studies have carefully

measured carboxyhemoglobin levels in response to inhaled CO and demonstrated that low dose carbon monoxide is safe in healthy normal volunteers<sup>76,79-84</sup>. Stewart et al. performed 25 exposures to known CO concentrations in healthy volunteers; in this study, exposure to 100 ppm CO for 8 hours resulted in COHb levels of 11-13% with no adverse effects in time estimation, steadiness, manual dexterity, EEG, and evoked potentials<sup>81</sup>. In a recent study aiming to simulate cigarette smoke inhalation, Zevin et al. exposed healthy volunteers to CO (1200-1500 ppm) for ten minutes, repeating every 45 minutes for 16 hours per day for 7 days<sup>82</sup>. In this study, mean COHb levels were  $5 \pm 1\%$  and no adverse events were reported<sup>82</sup>.

**Table 2: Clinical Trials of CO in Human Subjects**

Study	CO Exposure	COHb	Adverse Effects
Stewart (1970) <sup>81</sup>	100 ppm for 8 h	11-13%	No adverse effects
Peterson (1975) <sup>76</sup>	50-200 ppm, up to 5.25 h	1-20%	None noted
Hausberg (1997) <sup>79</sup>	1000 ppm x 30 min, then 100 ppm x 30 min	8.3 ± 0.5%	None reported
Zevin (2001) <sup>82</sup>	1500 ppm x 10 min, then every 45 min x 16 h for 7 days	5 ± 1%	None reported
Ren (2001) <sup>84</sup>	4000 ppm until COHb ~ 10%, then repeated to keep COHb ~ 10% for 8 h	9.7 ± 0.1%	None reported
Mayr (2005) <sup>80</sup>	500 ppm for 1 h	6.5-7.7%	Mild headache in 1 subject
Bathorn (2007) <sup>85</sup>	125 ppm for 2 h, 4 consecutive days	2.1-3.4%	2 COPD exacerbations, judged unrelated
Rhodes (2009) <sup>83</sup>	100 ppm for 1 h for 5 days	3.3 ± 0.6%	No adverse effects
NCT00094406 (IND# 70,694)	100 ppm for 6 h	6.5 ± 1.7%	No adverse effects
NCT01214187 (IND# 109,756)	100-200 ppm x 2 h, 2 times weekly x 12 wks	ongoing	Well tolerated, no SAEs related to CO

In a study evaluating the effects of hypoxemia, hemodilution, and carboxyhemoglobinemia on respiratory control, Ren et al. exposed 11 normal volunteers to a CO regimen aiming to maintain a COHb level of 10% for 8 hours<sup>84</sup>. COHb levels ranged from 9.1 to 10.5% (mean 9.7%) and no adverse effects were reported<sup>84</sup>. Similar results have been published in a number of other studies, and none have reported adverse events<sup>76,79,80,83</sup>. Of note, baseline COHb levels of 3% have been reported in some urban areas<sup>81</sup> and levels as high as 10-15% may be observed in asymptomatic chronic smokers<sup>86-88</sup>.

**Table 3: Effects of CO on Vital Signs and Laboratory Values**

Parameter	Room Air	CO 100 ppm	P-value
Respiratory rate	17.7 ± 3.6	16.7 ± 4.0	0.50
Heart rate	84.5 ± 14	83.8 ± 15	0.90
Temperature °C	36.9 ± 0.4	37.2 ± 0.4	0.15
Mean arterial pressure (mmHg)	92.8 ± 11	98.7 ± 11	0.21
Carboxyhemoglobin (%)	1.1 ± 0.7	6.5 ± 1.7	<b>0.001</b>
Oxyhemoglobin (%)	96.3 ± 2.1	92.3 ± 1.9	<b>0.002</b>
PaO <sub>2</sub>	96.5 ± 11	94.0 ± 7.3	0.54
Arterial pH	7.40 ± 0.02	7.41 ± 0.02	0.29
Lactate (mmol/L)	0.70 ± 0.26	0.62 ± 0.19	0.41

In addition, we demonstrated the safety of inhaled carbon monoxide in healthy volunteers after endotoxin instillation (NCT00094406-IND# 70,694). In this placebo-controlled study, 24 healthy volunteers (11 females; mean age 26.2 ± 5.2 yrs) were randomized to receive room air or CO (100

ppm) inhalation for 6 hrs starting immediately after bronchoscopic endotoxin instillation (4 ng/kg). In this study, subjects had a mean COHb of 6.5% ± 1.7% and CO inhalation was well tolerated and was not associated with any clinically significant abnormalities in vital signs, laboratory parameters,

neurocognitive studies (including immediate and delayed memory, attention, language and visuospatial/constructional function) or adverse events (**Table 3**).

In addition to the experience in normal volunteers, a recently completed clinical trial demonstrates the feasibility of administering a low dose of inhaled CO to humans with chronic obstructive pulmonary disease (COPD) (NCT00122694)<sup>85</sup>. In this study, ex-smoking subjects with stable COPD were treated with inhaled CO at 100–125 ppm for 2 hours per day on 4 consecutive days. This led to COHb levels of 2.1-3.4% with a maximal individual COHb level of 4.5%. Inhalation of CO by subjects with stable COPD led to trends in reduction of sputum eosinophils and improvement of methacholine responsiveness<sup>85</sup>. Finally, low dose inhaled CO has been administered to subjects with idiopathic pulmonary fibrosis in an ongoing multicenter phase II clinical trial with no serious adverse events related to CO therapy reported to date (NCT01214187- IND# 109,756). Taken together, these findings demonstrate that experimental administration of several different concentrations of CO is well tolerated and that low dose inhaled CO can be safely administered to subjects in a controlled research environment.

### 1.6. Steady State Diffusing Capacity and the Safety of Inhaled Carbon Monoxide

CO is also a diagnostic gas that has been used for more than a century to evaluate lung function, and in particular, in the steady state diffusing capacity test to determine the function of the alveolar-capillary membrane. The steady state method of measuring the diffusing capacity of the lung dates back more than 100 years, based on the research of Haldane and Smith. In the early 1900's, Krogh and Barcroft developed it into a standard test procedure for both understanding alveolar membrane function as well as diagnosing diseases of the alveolar-capillary membrane. Up until the 1970's, steady state diffusing capacity was the standard diagnostic test for pulmonary laboratories worldwide when it was replaced by the single breath diffusing capacity test due to its better accuracy and being less time consuming. The steady state diffusing capacity test is still used today in some instances where the single breath procedure is not as practical, such as measurements during exercise. The procedure for steady state diffusing capacity testing entails patients inhaling 0.1% CO (1000 ppm) for seven minutes<sup>89</sup>. As duplicate or triplicate measurements are required for most lung function tests, this suggests that hundreds of thousands of people have inhaled 1000 ppm for 14 to 21 minutes with no known reports of adverse events associated with the test. Based on the curves from the CFK equation (**Figure 1**), it is likely that this same number of people had their carboxyhemoglobin levels raised above 3-6% following the diagnostic procedure. This longstanding diagnostic procedure reinforces that inhaling a constant concentration of low dose carbon monoxide can be safely done without significant adverse events.



**Figure 2. CO Delivery System (12<sup>th</sup> Man Technologies)**

### 1.7. Delivery of inhaled CO to mechanically ventilated subjects

In order to study inhaled CO in mechanically ventilated subjects with ARDS in this Phase I trial, a Carbon Monoxide Delivery System (**Figure 2**) developed by 12<sup>th</sup> Man Technologies will be used (**Appendices O and P- CO Delivery System**). The CO Delivery System is a microprocessor-based constant gas concentration delivery system that can be used to deliver operator specified concentrations of CO to mechanically ventilated patients. The CO Delivery System delivers an operator set, constant concentration of carbon monoxide gas into the inspiratory path of the patient breathing circuit independent of the

patient's inspiratory flow, while the patient's respiration is supported by a ventilator. For safety reasons, the CO Delivery System has twin microprocessors so that the division of control is split between a closed loop proportional-integral-derivative (PID) controlled mixing module that is only involved with monitoring the patient flow and mixing of the gases and an interface module that is the working face to the user for control and monitoring functions. This second microprocessor watches the delivery subsystem, monitors the inspired gas for deviations from the set concentration, and monitors inspired oxygen.

The heart of the system is comprised of three components including an inspiratory flow monitor with a ratio-metric matching CO injector module, an inhaled gas monitoring module, and a gas mixing subject interface/breathing valve for spontaneously breathing subjects. It is a variable inspiratory flow delivery system that matches the patient's inspiratory flow with the injected 5000 ppm CO to deliver the operator set CO concentration on the LCD user interface. It is a breathing initiated delivery system and the CO is blended into the inspiratory gas stream only as long as flow is being delivered to the patient and at the exact proportions to maintain the desired concentration, independent of any change in breathing pattern, flow rate, respiratory rate, or tidal volume. The analyzer, with alarm functions, monitors the inhaled carbon monoxide and oxygen concentrations.

The CO Injector is a core component for the delivery of CO. The CO Injector is constructed of carbon monoxide compatible materials and consists of a pressure regulation circuit that reduces the 40-60 psig inlet CO gas source to the optimal pressure for its proportional flow control valve. Upon sensing inspiratory flow by the patient with the flow monitoring interface, the injector module will track the flow and match the volume of carbon monoxide injected to the volume of inspired gas to keep the concentration of CO constant independent of the patient's pattern of inspiratory flow. The PID controlled mixing module's sole function is to read the patient's inspiratory flow and inject CO proportional to that flow in 1 millisecond intervals. Alarms will sound on high or low CO or O<sub>2</sub> concentrations. Should the inspired CO concentration rise above 660 ppm, in addition to the alarms, the system will stop injecting CO into the circuit.

### **1.8. Testing of the CO Delivery System in a Baboon Model of Pneumococcal Pneumonia**

We evaluated the safety and efficacy of the CO Delivery System developed by 12<sup>th</sup> Man Technologies in a baboon model of *S. pneumoniae* pneumonia. Four juvenile, male colony-bred baboons (*Papio cynocephalus*) were intubated, sedated, and mechanically ventilated<sup>90</sup> with a Puritan Bennett 840 ventilator in volume-control mode. The animals underwent bronchoscopy and a baseline bronchoalveolar lavage (BAL) was performed followed by instillation of *Streptococcus pneumoniae* (10<sup>8</sup> - 10<sup>9</sup> CFU) in the right and left lower lung zones. At 24 or 48 hours post-inoculation, animals were sedated, intubated, ventilated, and underwent a repeat bronchoscopy and BAL. The CO Delivery System was calibrated using 100 ppm and 400 ppm CO tanks and readied for use with a 5000 ppm CO source cylinder. All CO tanks contained CO gas at the specified concentration in air. Ambient CO levels were monitored during the CO delivery device assembly, calibration, and continuously throughout the experiment using a CO detector.

Following bronchoscopy, animals were administered CO at 200 ppm through the ventilator via the CO Delivery System for 60-90 minutes. After CO treatment was completed, animals were administered supplemental FiO<sub>2</sub> for 60-90 minutes until COHb levels returned to near baseline levels. Arterial blood was drawn before, during, and after CO delivery at 10-15 minute intervals and arterial blood gas (ABG) and COHb measurements were performed. In certain experiments, both venous and arterial blood samples were drawn simultaneously for measurement of venous and arterial COHb levels and blood

gases respectively. COHb levels were measured using the IL 682 Co-Oximeter and, in certain experiments, using the AVOXimeter 4000 Co-Oximeter. After CO exposure, animals were administered ceftriaxone daily for a total of 3 days.

Animals met pre-specified pneumonia criteria (white blood cell count, microbiology, and signs/symptoms) as previously defined<sup>90</sup>. At 24-48 hours post-inoculation, animals developed fever ( $39.2 \pm 0.8^\circ \text{C}$ ), tachycardia (HR  $125 \pm 15$  beats/min), and tachypnea (RR  $39 \pm 8$  breaths/min, or  $25 \pm 16\%$  above baseline). Mean arterial blood pressure was unchanged throughout the experiment. Chest radiographs showed bilateral lower lobe opacities. Laboratory analysis was notable for hypoxemia (PaO<sub>2</sub>  $76 \pm 7$  mm Hg) and leukocytosis ( $17.9 \pm 5$  thousand/ $\mu\text{L}$ ) with 90% neutrophils on differential. At 168 hours, there was a late-onset thrombocytosis ( $669 \pm 52$  thousand/ $\mu\text{L}$ ). BAL fluid (BALF) gram stain at 24-48 hours demonstrated numerous neutrophils with moderate gram-positive diplococci consistent with *S. pneumoniae*. *S. pneumoniae* was isolated from BALF at 48 hours ( $8.4 \times 10^4 \pm 7.1 \times 10^4$

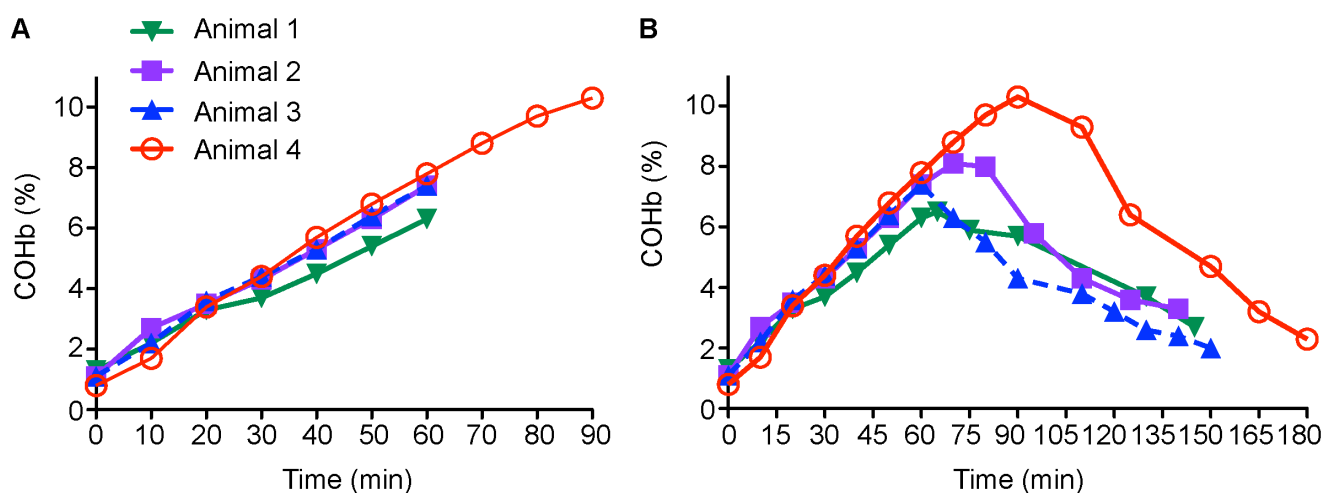

**Figure 3. Inhaled CO at 200 ppm for one hour achieves desired goal COHb level.**

CFU/mL) and from blood at 24-48 hours ( $14 \pm 10$  CFU/mL); however, BALF and blood were sterile at 168 hours. Pneumococcal urinary antigen was negative at baseline but detected in all animals at 24, 48, and 168 hours post-inoculation. Post-mortem examination of the lungs at 168 hours revealed minimal to moderate bilateral lower lobe consolidation, without pleural effusions or pleuritis. H&E stained lung tissue showed mild alveolar filling by mononuclear cells with and without fibrin.

Following one hour of CO administration at 200 ppm, animals achieved the pre-specified desired goal COHb level of 6-8% ( $7.2 \pm 0.6\%$ ). Arterial COHb levels were  $1.07 \pm 0.2$  at baseline, and increased linearly to  $2.2 \pm 0.4\%$ ,  $3.45 \pm 0.1\%$ ,  $4.2 \pm 0.3\%$ ,  $5.2 \pm 0.5\%$ ,  $6.2 \pm 0.6\%$ , and  $7.2 \pm 0.6\%$  at 10, 20, 30, 40, 50 and 60 minutes of CO administration, respectively ( $p=0.0002$ ) (**Figure 3A**). One animal was intentionally subjected to a prolonged (90 minute) exposure which similarly demonstrated a linear rise in COHb to 7.8%, 8.8%, 9.7%, and 10.3% at 60, 70, 80, and 90 minutes, respectively. Peak COHb levels decreased following administration of 1.0 FiO<sub>2</sub>, returning to near baseline levels after  $82 \pm 9.5$  minutes (**Figure 3B**).

Using the IL 682 Co-Oximeter, we found that venous and arterial COHb levels were highly correlated ( $r=0.9904$ ,  $p<0.0001$ ). Modeling these data with type II linear regression, we found that the regression line was a near-perfect diagonal with a slope of 1.003 (95% CI [0.952 – 1.05]) and a y-intercept of -0.064 (95% CI [-0.2941 – 0.1661]). (**Figure 4**). This tight correlation argues that venous measurements



are as accurate and reliable as arterial measurements. We also found superior accuracy and precision of the IL 682 Co-Oximeter compared with the AVOXimeter 4000 Co-Oximeter. The IL 682 Co-Oximeter had increased sensitivity to measure COHb, especially at low COHb levels, compared with the AVOXimeter 4000 Co-oximeter. Modeling these data with type II linear regression, we found that the regression line was a poor model of the data with a slope of 0.6062 (95% CI [0.4937 – 0.7188]) and a y-intercept of -2.233 (95% CI [-2.828 – -1.638]) (Figure 5).

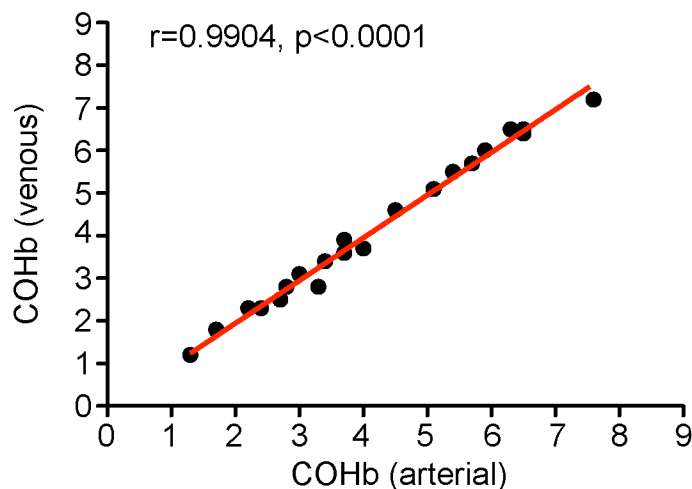

**Figure 4. Correlation between venous and arterial COHb.**

Labor, Occupational Safety & Health methods/inorganic/id209/id209.html).

### 1.9. CO Dosing Strategy Using CFK Equation

In order to develop a safe and effective dosing strategy based on an initial short exposure to inhaled CO, we also evaluated the accuracy of the Coburn-Forster-Kane (CFK) equation (below, Appendix B)<sup>71,76</sup> to predict COHb levels using measured COHb levels following a 10 and 20 minute CO exposure. Using the 10 minute COHb, we found that there was good correlation between measured COHb levels and the COHb levels predicted by the CFK equation (r=0.9251, p<0.0001). However, there was superior correlation between measured COHb levels and COHb levels predicted by the CFK equation using the 20 minute

$$\frac{A[\text{HbCO}]_t - B\dot{V}_{\text{CO}} - P_{\text{ICO}}}{A[\text{HbCO}]_0 - B\dot{V}_{\text{CO}} - P_{\text{ICO}}} = \exp(-tA/VbB)$$

CI [0.9468 – 1.057]) with a y-intercept of 0.423 (95% CI [0.056 – 0.789]) and R<sup>2</sup>=0.9878 (p<0.0001). Furthermore, the 20 minute COHb was highly accurate in predicting the 60 minute COHb with a difference between predicted and actual COHb of 0.28 ± 0.43% (95% CI [-0.4 – 0.97]) (Figure 6B). Using the 20 minute COHb level as input into the CFK equation, this method can be used to predict the 60 minute COHb level with high accuracy.

### 1.10. Programming of the CFK equation

Ambient CO levels in the experiment room remained at 0-1 ppm during assembly, calibration, and use of the CO delivery device. These levels are well below the OSHA permissible exposure limit of 50 ppm as an 8 h time-weighted average U.S. Department of Administration, <https://www.osha.gov/dts/sltc/>

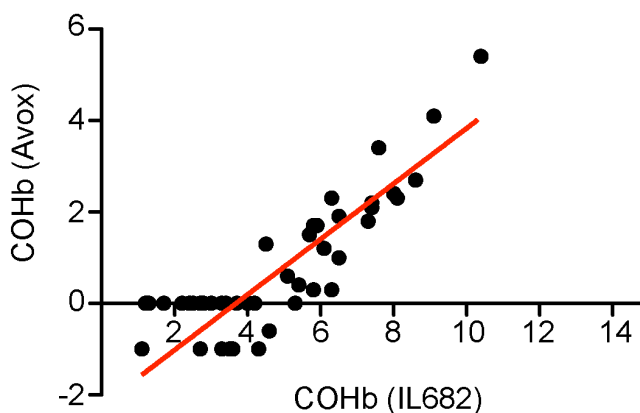

**Figure 5. Measurement of COHb levels by Avox4000 versus IL682 Co-Oximeters.**

COHb (r=0.9767, p<0.0001) (Figure 6A). Modeling these data with linear regression, we found that the regression line was a near-perfect diagonal with a slope of 1.002 (95%

The above predictions using the CFK equation were made using a computer program generated in

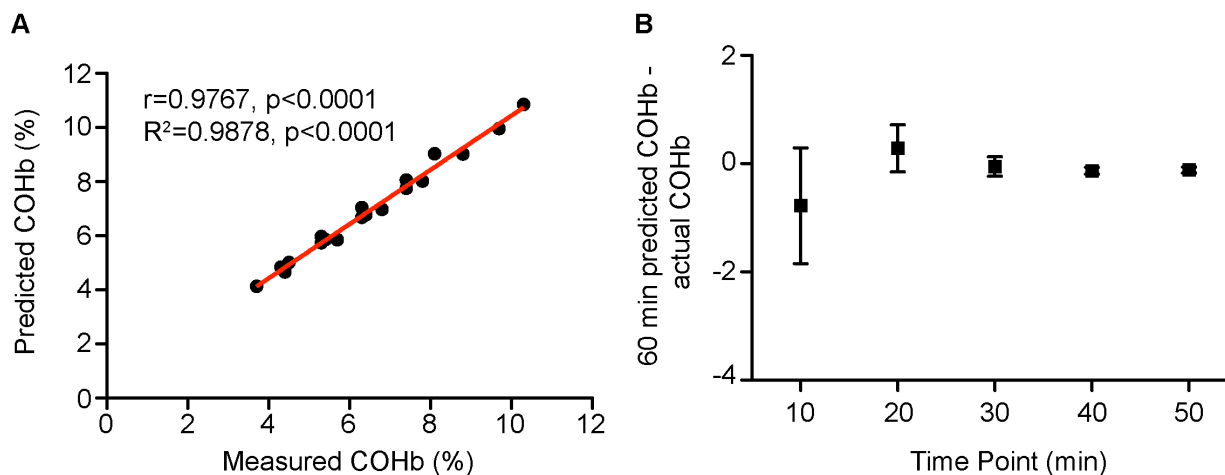

**Figure 6. Exposure to CO for 20 min allows for accurate prediction of 60 min COHb using CFK equation.**

MATLAB to estimate DLCO using the baseline and 20 minute COHb. The estimated DLCO was then input into the programmed CFK equation and used to predict the 60 minute COHb. This program was validated by generating the previous published curves (**Figure 1**) that were derived from predicted values using the CFK equation<sup>76</sup> (**Appendix B**). In addition, we used the programmed CFK equation and published values for CFK variables in ARDS (DLCO,  $V_A$ , Hgb, weight,  $FiO_2$ ) to predict COHb levels in ARDS patients (average and severe) for a given CO concentration and duration of exposure (**Appendix C**).

### 1.11. Study Rationale

The purpose of this study is to assess the safety of inhaled CO therapy in mechanically ventilated patients with sepsis-induced ARDS. By studying subjects with sepsis and ARDS, we have targeted diseases that have been well studied in animal models. Furthermore, by focusing on intubated subjects with sepsis-induced ARDS, we have chosen a group with higher disease burden than sepsis alone and thus likely to have both increased mortality and an increased opportunity for benefit, including a reduction in the requirement for mechanical ventilation.

Mitochondrial dysfunction is associated with increased disease severity and poor outcomes during sepsis and may be a key mechanism underlying ARDS and multiple organ dysfunction syndrome during sepsis<sup>91</sup>. Furthermore, early activation of mitochondrial biogenesis has been associated with improved survival in critically ill patients with sepsis<sup>92</sup>. CO has been shown to activate mitochondrial biogenesis<sup>83</sup> and may be a key mechanism by which CO protects against ARDS and organ failure during sepsis. The optimal dose and duration of CO therapy in sepsis-induced ARDS is unknown. The decision to examine five days of treatment in Phase 1 is based on trials in healthy volunteers demonstrating activation of skeletal muscle mitochondrial biogenesis with no toxicity after 5 days of CO exposure<sup>83</sup>.

The rationale to examine a dose escalation of 100 and 200 ppm in Cohorts 1 and 2 is to demonstrate safety of low dose inhaled CO treatment in intubated patients with sepsis-induced ARDS. It is anticipated that the COHb levels in Cohorts 1 and 2 will be well below the target range for Cohort 3 (6-8%) given reductions in CO diffusion in patients with ARDS. However, this low dose escalation design was favored as an additional safety measure in this vulnerable population. The decision to target a COHb level of 6-8% in Cohorts 3 is based on human studies that demonstrate activation of skeletal

muscle biogenesis and safety of COHb levels of 6-8% (**Table 2**)<sup>76,79,80,82-85</sup>. Given diffusion impairment in patients with ARDS, it is anticipated, based on CFK equation predictions (**Appendix C**), that patients will require doses in the range of 200-500 ppm to achieve COHb levels of 6-8%. The decision to limit the maximal dose to 500 ppm in Cohort 3 is based on concern for potential epithelial toxicity at inhaled concentrations above 500 ppm. Previous studies have demonstrated safety of CO inhalation at 500 ppm in humans<sup>80</sup> and reduction of pulmonary neutrophilia in non-human primates<sup>49</sup>, therefore we do not anticipate epithelial toxicity at our maximal dose in Cohort 3.

## 2. Objectives and Study Design

### 2.1. Study Objective:

To assess the safety of inhaled carbon monoxide (iCO) in intubated patients with sepsis-induced ARDS.

### 2.2. Hypotheses:

- Administration of inhaled CO therapy will be safe in intubated patients with sepsis-induced ARDS.
- CO dosing approach will be safe and effective in determining patient-specific CO dose to achieve a target COHb of 6-8% (Cohort 3).

### 2.3. Study Design:

We will perform a multi-center, prospective, randomized, placebo-controlled Phase 1 clinical trial of inhaled CO for the treatment of sepsis-induced ARDS. Intubated subjects with sepsis-induced ARDS will be randomized to inhaled CO versus inhaled air placebo for up to 90 minutes daily for a total of 5 days **in three separate cohorts**. The DSMB will meet after each cohort to determine whether to proceed to the subsequent cohort (**Section 7.3**).

**Cohorts 1-2:** randomized, placebo-controlled, multi-center, dose escalation study (all sites-BWH, MGH, Duke, Cornell)

**Cohort 1:** iCO at 100 ppm or placebo for up to 90 minutes daily for a total of 5 days

**Cohort 2:** iCO at 200 ppm or placebo for up to 90 minutes daily for a total of 5 days

**Cohort 3:** multi-center, open label algorithm-specified iCO dose (not to exceed 500 ppm) to achieve a COHb of 6-8% based on dosing algorithm confirmed predictive and safe in Cohorts 1-2

**Cohort 3:** open label algorithm-specified dose of iCO for up to 90 minutes daily for a total of 5 days (all sites)

### 2.4. Accrual Objective for Cohort Completers:

**Cohort 1:** 4 subjects receiving iCO 100 ppm; 2 subjects receiving inhaled air placebo (all sites)

**Cohort 2:** 4 subjects receiving iCO 200 ppm, 2 subjects receiving inhaled air placebo (all sites)

**Cohort 3:** 6 subjects receiving variable dose iCO, titrated to COHb 6-8%

#### **2.4.1. Cohort Completers:**

All enrolled subjects that initiate study drug dosing procedures, as described in Section 5.1.6, will be included in the primary safety analysis. A subject will be considered a cohort completer if they meet the criteria in Section 5.1.10. Because some patients may withdraw or have a change in clinical status precluding dosing of study drug (eg. post randomization lactic acidosis), we may randomize additional patients to achieve the number of cohort completers identified in Section 2.4. We expect this to be an uncommon occurrence.

For cohort 1, we will enroll up to 4 additional subjects in order to achieve the accrual objective for cohort completers in Section 2.4.

For cohort 2, we will enroll up to 4 additional subjects in order to achieve the accrual objective for cohort completers in Section 2.4.

For cohort 3, we will enroll up to 4 additional subjects in order to achieve the accrual objective for cohort completers in Section 2.4.

#### **2.5. Study Product, Dose, Route, and Regimen:**

The study drug will be administered to mechanically ventilated subjects based on a dosing algorithm and using a CO delivery device tested in pre-clinical non-human primate models. All study drug doses will be administered via inhalation using a mechanical ventilator approved for NO delivery and the CO Delivery System. The study drug will be blinded to the study coordinator using identical tanks containing either CO or placebo air. The administering respiratory therapist and a physician study staff member will be unblinded to the treatment assignments.

For all cohorts, each dose of iCO or inhaled air placebo will be administered to subjects on a mechanical ventilator via the CO delivery device for up to 90 minutes. All patients will receive one dose daily for 5 days (as tolerated based upon safety stops built into the protocol).

##### **Cohort 1: Dose Escalation, Part I**

100 ppm iCO or placebo for up to 90 minutes (n=6; 2:1 ratio) (all sites)

**[STOP for DSMB REVIEW, (Section 7.3.)]**



##### **Cohort 2: Dose Escalation, Part II**

200 ppm iCO or placebo for up to 90 minutes (n=6; 2:1 ratio) (all sites)

**[STOP for DSMB REVIEW, (Section 7.3.)]**



**Cohort 3: Algorithm-specified dose**

CO dose predicted by algorithm for up to 90 minutes to reach COHb 6-8% based on a 200 ppm iCO test dose for 20 min (n=6 open label CO) (all sites)

**[DSMB REVIEW, (Section 7.3.)]**

### **3. Endpoints**

#### **3.1. Primary Endpoint**

The primary endpoint is safety of inhaled CO, defined by the incidence of pre-specified administration-associated adverse events and severe adverse events, in sepsis-induced ARDS patients.

#### **3.2. Secondary Endpoint**

The secondary endpoint is determination of the accuracy of the inhaled CO dosing approach in intubated patients with sepsis-induced ARDS.

#### **3.3. Other Secondary Endpoints:**

1. Mean daily Sequential Organ Failure Assessment (SOFA) score
2. PaO<sub>2</sub>/FiO<sub>2</sub> ratio and Oxygenation Index
3. Lung injury score
4. Vasopressor-free days
5. Ventilator-free days
6. ICU-free days at day 28
7. Hospital-free days at day 60
8. Hospital mortality to day 28 and 60
9. Plasma biomarkers of inflammation (IL-6, IL-8, IL-10, IL-1Ra, IL-18, IL1 $\beta$ , and circulating mitochondrial DNA), lung epithelial injury (RAGE), endothelial injury (vWF, Ang-2), markers of change in other end-organ function (e.g., creatinine, liver function tests, lactate)

#### **3.4. Focused Safety Analysis:**

The incidence of elevation in plasma COHb  $\geq$  10% measured on study days 1-5 and pre-specified administration-associated adverse events (**Section 5.1.9.**) and serious adverse events (**Section 11.**).

### **4. Study Population and Enrollment**

#### **4.1. Screening**

Study coordinators will screen intensive care units daily to identify potential subjects for enrollment. Permission to approach patients and/or their families will be requested from the attending physicians. All patients meeting the inclusion criteria will be entered into a screening log. If the patient is not enrolled, the screening log will include information explaining why enrollment did not occur (exclusion

criteria, attending physician denial, patient refusal, etc. see **Appendix D** for a listing of the de-identified data to be collected on screened, non-enrolled subjects).

#### **4.2. Inclusion Criteria:**

All patients (age 18 and older) will be eligible for inclusion if they meet all of the below criteria for sepsis and ARDS.

- Patients with sepsis are defined as those with suspected or documented infection:
  - Suspected or proven infection: Sites of infection include thorax, urinary tract, abdomen, skin, sinuses, central venous catheters, and central nervous system (**Appendix A**).

All eligible patients meet the new definition of sepsis (suspected or proven infection and a SOFA  $\geq$  2) as PaO<sub>2</sub>/FiO<sub>2</sub> ratio  $<$  300 = 2 SOFA points<sup>1</sup>.

- ARDS is defined when all four of the following criteria are met:
  1. A PaO<sub>2</sub>/FiO<sub>2</sub> ratio  $\leq$  300 with at least 5 cm H<sub>2</sub>O positive end-expiratory airway pressure (PEEP)
  2. Bilateral infiltrates consistent with pulmonary edema on frontal chest radiograph
  3. A need for positive pressure ventilation by an endotracheal or tracheal tube
  4. No clinical evidence of left atrial hypertension for bilateral pulmonary infiltrates.
- ARDS onset is defined as the time the last of criteria 1-4 are met. ARDS must persist through the enrollment time window of 120 hours.
- Infiltrates considered “consistent with pulmonary edema” include any infiltrates not fully explained by mass, atelectasis, or effusion or opacities known to be chronic (greater than 1 week). Vascular redistribution, indistinct vessels, and indistinct heart borders alone are not considered “consistent with pulmonary edema” and thus would not count as qualifying opacities for this study.

#### **4.3. Exclusion Criteria:**

1. Age less than 18 years
2. Greater than 120 hours since ARDS onset
3. Pregnant or breast-feeding
4. Prisoner
5. Patient, surrogate, or physician not committed to full support (exception: a patient will not be excluded if he/she would receive all supportive care except for attempts at resuscitation from cardiac arrest)
6. No consent/inability to obtain consent
7. Physician refusal to allow enrollment in the trial
8. Moribund patient not expected to survive 24 hours
9. No arterial line/no intent to place an arterial line
10. No intent/unwillingness to follow lung protective ventilation strategy

## A Phase I Trial of Inhaled Carbon Monoxide for the Treatment of Sepsis-Induced ARDS

11. Severe hypoxemia defined as  $SpO_2 < 95$  or  $PaO_2 < 80$  on  $FiO_2 \geq 0.8$
12. Hemoglobin  $< 7.5$  g/dl or hemoglobin  $< 8$  g/dl and actively bleeding
13. Subjects who are Jehovah's Witnesses or are otherwise unable or unwilling to receive blood transfusions during hospitalization
14. Acute myocardial infarction or acute coronary syndrome within the last 90 days
15. Coronary artery bypass graft (CABG) surgery within 30 days
16. Angina pectoris or use of nitrates with activities of daily living
17. Cardiopulmonary disease classified as NYHA class IV
18. Stroke (ischemic or hemorrhagic) within the prior 3 months
19. Diffuse alveolar hemorrhage from vasculitis
20. Use of high frequency ventilation
21. Participation in other interventional studies involving investigational agents
22. Burns  $> 40\%$  total body surface area
23. Use of inhaled pulmonary vasodilator therapy (eg. NO or prostaglandins)

### **Reasons for Exclusions:**

Patients less than 18 years of age are excluded because the study ICUs do not admit pediatric patients. Patients with ARDS for more than 120 hours are excluded to evaluate more clearly the effects of CO early in the course of lung injury. Patients with severe hypoxemia are excluded because they do not have adequate reserve to tolerate the reduction in oxygen carrying capacity. Patients with hemoglobin  $< 7.5$  g/dl, hemoglobin  $< 8$  g/dl and actively bleeding, Jehovah's witnesses, or patients otherwise unable or unwilling to receive blood transfusions during hospitalization are excluded because of the volume of blood required for monitoring during CO therapy may place these patients at greater risks from complications of anemia. Moribund patients and patients with large body surface area burns have a high incidence of adverse events and lactic acidosis that will confound the safety assessment. Pregnancy and recent stroke are exclusions because CO may reduce oxygen delivery to the fetus and recently injured brain respectively. Patients with alveolar hemorrhage from vasculitis are excluded because the mechanism of lung injury is different from ARDS and diffuse alveolar damage. Patients with acute myocardial infarction within 90 days, recent CABG, and angina pectoris are excluded because of a potential excess risk of reducing oxygen delivery to the myocardium. Patients with congestive heart failure are excluded because of concerns about ventricular arrhythmias. Patients ventilated with high frequency ventilation are excluded because dosing of CO during this mode of ventilation is unreliable. Patients on inhaled pulmonary vasodilators are excluded as these inhaled medications may interfere with the dosing of inhaled CO.

### **4.4. Enrollment, Randomization, and Study Initiation Time Window**

All ARDS criteria must occur within the same 24 hour period. The onset of ARDS is when the last criterion is met. Patients must be enrolled within 120 hours of ARDS onset. Information for determining when these time window criteria were met may come from either the site hospital or a referring hospital reports. Following randomization, the low tidal volume protocol for mechanical ventilation must be initiated within one hour.

The first treatment of study drug must be given within 24 hours of randomization. The day of randomization will be considered study day zero. Study day 1 will be the 24 hour period following randomization. Following randomization, the low tidal volume protocol for mechanical ventilation must be initiated within one hour.

#### **4.5. Informed Consent**

Written informed consent will be obtained from each patient or surrogate. If available, informed consent will be obtained from, in order of preference: the subject's court appointed guardian or from a health care proxy/person with durable power of attorney. If no such representative exists, then the subject's "next of kin" will be approached, consistent with hospital policy for obtaining consent for other medical procedures. Informed consent will be sought from the following individuals, in the order listed: spouse; natural or adoptive parent; adult child; adult brother or sister; any other available adult relative related through blood or marriage known and documented to have made decisions for the subject in prior health care settings. Patients who regain decision-making capacity prior to discharge from the study hospital will be asked to provide written consent for ongoing participation in the study. No study procedure will be conducted before obtaining informed consent. If consent from a Legally Authorized Representative (LAR) or surrogate cannot be obtained in person on behalf of a subject with impaired decision-making capacity, a licensed physician investigator may call the subject's LAR to perform consent by phone using an IRB-approved telephone script. Consent obtained by telephone must comply with all regulatory requirements about the process, the consent elements, and documentation of consent.

#### **4.6. Enrollment and Randomization**

Site investigators will review all potential study participants with one of the Data Coordinating Center (DCC) physician members. Once a potential participant has completed screening and is determined to meet eligibility criteria, the site personnel will call or page the DCC physician to request a randomization number and study assignment. The DCC personnel will enter a randomization number and an assigned treatment from the pre-provided randomization list into the unblinded electronic database. The DCC will also notify the site investigator of the assigned treatment by phone. The site investigator or person administering the study drug will log into the database to find out the subject's treatment assignment and note this in the Subject Drug Administration form.

In cohorts 1 and 2, eligible participants will be randomized to one of the two treatment arms using a permuted block method<sup>93</sup>. Randomization ratio will be 2 (iCO):1 (placebo) for cohorts 1 and 2. Patients in cohort 3 will receive open label CO. A biostatistician will generate the randomization codes and incorporate into the REDCap randomization module. The site investigator will call or page an unblinded DCC physician member to request a randomization number and study assignment which will be obtained from the REDCap randomization module.

The study coordinators at each site who are responsible for data entry will be blinded to the study treatment assignments. The respiratory therapist and a physician study staff member administering the study drug will conceal the gas cylinders, the CO delivery device, and measurements of COHb, SpCO, and ambient CO levels, to assure that the study coordinator remains blinded to the study drug assignment. The physician study staff member will be responsible for maintaining a separate password-protected file with the subject identification number and CO-related measurements (SpCO, COHb, ambient CO) which the study coordinator will not have access to. While investigators will be unblinded throughout the study due to safety monitoring in the Phase 1 trial, they will only be unblinded to the



treatment assignment for subjects enrolled at their own site. Investigators will otherwise be blinded to the study treatment assignment for subjects enrolled at the other three sites. This will prevent investigators from knowing the treatment assignment of the fifth or sixth patient enrolled into cohort 2. A lead respiratory therapist and co-investigator at MGH (Dr. Hess) may become unblinded to the treatment assignments at other sites to assist with study drug administration procedures if necessary.

As for adverse event adjudication, the Medical Monitors (Drs. Baron and Thompson) will review the events in an unblinded fashion as is currently recommended by the FDA for SAEs (Guidance for Industry and Investigators Safety: Reporting Requirements for INDs and BA/BE Studies (Section VI.C); December 2012). We do not see a way around site level adjudication by the site PIs evaluating AEs with knowledge of the treatment assignment but do conduct a 100% audit of source documents for unreported AEs.

Central review of randomization by the DCC physician will assure that no subjects are enrolled in this multicenter Phase 1 study during planned or unplanned study holds. The DCC will pause enrollment and notify all sites of any planned or unplanned study holds.

## **5. Study Procedures**

### **5.1 CO or Placebo Study Procedures**

#### **5.1.1. Study Drug Dose**

The study drug will be administered as follows:

- Subjects in Cohort 1 will be treated with inhaled CO at a dose of 100 ppm or placebo. (all sites)
- Subjects in Cohort 2 will be treated with inhaled CO at a dose of 200 ppm or placebo. (all sites)
- Subjects in Cohort 3 will be treated with inhaled CO at a concentration determined by a dosing algorithm (**5.1.6.**) in order to achieve a COHb level of 6-8%. (all sites)

Placebo will consist of medical-grade air in identical appearing gas cylinders.

#### **5.1.2. Treatment Period**

The study drug will be administered for up to 90 minutes daily for five days following randomization or until discontinuation of mechanical ventilation, whichever occurs first. For patients who have a tracheostomy, the equivalent of extubation for the purposes of this protocol will be breathing via tracheostomy with unassisted breathing.

#### **5.1.3. CO Delivery System**

Inhaled CO or placebo will be administered to mechanically ventilated subjects using a mechanical ventilator approved for NO delivery and the CO Delivery System developed by 12<sup>th</sup> Man Technologies (**Figure 2, Appendices O and P**). See **Appendices O and P** for details of the CO Delivery Device testing, assembly, calibration, and standard operating procedures (SOP). The CO Delivery System will be calibrated and connected to the ventilator (**Figure 7**) as described in **Appendices O and P**. As per the SOP and illustrated in the schema in **Figure 7**, the injector module will be connected between the

inspiration port of the ventilator and inlet port of the humidifier. The gas sampling line will be placed between the outlet port of the humidifier and the patient wye as shown.

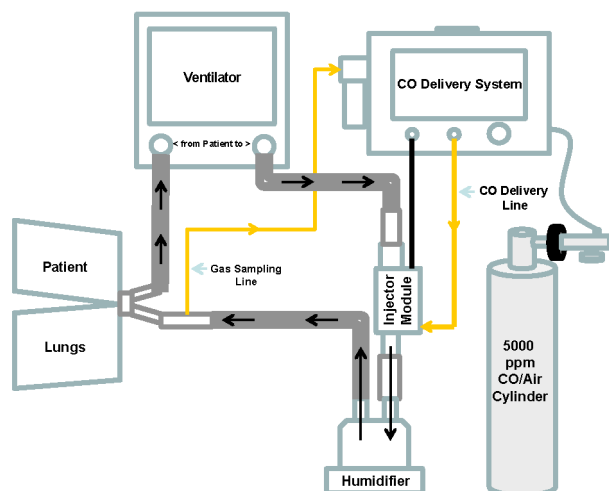

**Figure 7. Schema of CO Delivery System and ventilator.**

**for Chemistry data).** The cylinder contains approximately 360 liters of 5000 ppm (0.5%) Carbon Monoxide in room air (21% oxygen) and poses no increased flammability risk. Placebo tanks will contain medical grade air (**see attached letter from Praxair for Chemistry data**). The gas cylinder’s nominal size is 5 inches in diameter by 17 inches tall. See **Appendix P** for potential leak sources that could release CO into the room besides through the exhalation valve. Given the flow limitation from the regulator of ~7 liters per minute and a minimum of 6 air exchanges per hour in an average 15x15x10 ICU room, we do not expect ambient CO levels to exceed the OSHA permissible exposure limit (PEL) of 50 ppm as an 8 hour time-weighted average. We measured ambient CO levels during our animal studies using the CO Delivery System and were unable to detect increases in ambient CO levels throughout assembly, calibration, and delivery of CO to the animals. In addition, we simulated CO administration with an ICU ventilator (Puritan-Bennett 840), CO Delivery System, and lung model in an ICU room at the MGH at 500 ppm for over 2 hours and ambient CO levels were near zero and well below the OSHA PEL (**Appendix E**).

### 5.1.5. CO Monitoring

Subjects will have blood drawn daily for measurement of lactate as well as COHb using an IL682 Co-Oximeter (**Appendix L**) prior to administration of study drug. If COHb  $\geq 3\%$  or lactate  $\geq 4$  mmol/L, the study drug will not be given on that study day. In addition, subjects will also have baseline SpCO measured noninvasively using a Masimo Radical 7 (Rad-7) pulse oximeter. During and after administration of the study drug, carboxyhemoglobin levels will be measured invasively (COHb by IL682) at the following time points: 20 min, 60 min, 75 min, 90 min, and 3 hours. In addition, COHb will be monitored continuously throughout the treatment period with a noninvasive pulse oximeter (SpCO by Rad-7).

The concentration of the study drug will be measured by the built-in gas monitor in the CO Delivery System. The CO Delivery System contains an inhaled gas monitor which is an electrochemical device that monitors the inhaled gas for concentrations of CO (0-800 ppm) and O<sub>2</sub> (15-100%) to assure that safe levels are inhaled. The sample pump maintains a constant flow of gas to the sensors. Samples of

The study drug will be administered by a respiratory therapist and a physician study staff member will be present at the bedside during and immediately after administration of the study drug for any clinical concerns that arise. The administering respiratory therapist and a physician study staff member will be unblinded to the treatment assignments and will conceal the gas cylinders and CO delivery device to assure that the study coordinator remains blinded to the study drug assignment.

### 5.1.4. CO or Placebo Cylinders

The gas cylinders proposed for this clinical trial are AG aluminum cylinders with a CGA 500 valve and will be supplied by Praxair (**see attached letter from Praxair**

## A Phase I Trial of Inhaled Carbon Monoxide for the Treatment of Sepsis-Induced ARDS

inspired gases are taken with a continuous ~400 mL/min sample pump just proximal to the patient's airway to reflect actual inspired gases. Alarms will sound on high or low CO or O<sub>2</sub> concentrations.

Ambient air CO concentrations will be measured in real time with a Dräger Pac 7000 CO detector to assure that ambient levels are maintained within the recommended limits for occupational exposure of a maximum of 50 ppm. Ambient air carbon monoxide detectors will be calibrated every 6 months per the manufacturer's instructions to ensure proper functioning.

All CO monitoring will be carried out by the administering respiratory therapist and/or the physician study staff member and concealed from the study coordinator. The physician study staff member will be responsible for maintaining a separate password-protected file with the subject identification number and CO-related measurements (SpCO, COHb, ambient CO) which the study coordinator will not have access to.

### 5.1.6. CO Dosing Algorithm Using the CFK Equation

Patients in Cohorts 1 and 2 will be administered inhaled CO at 100 and 200 ppm, respectively, for up to 90 minutes. Subjects randomized to placebo will be administered inhaled air using the identical delivery system and ventilator. COHb will be measured at baseline and after 20 minutes of CO treatment. The CFK equation will be used to predict the 90 minute COHb level. **No adjustment in the CO concentration will be made in Cohorts 1 and 2.**

1. Arterial blood (2.5 ml) will be drawn for baseline ABG and COHb prior to CO or placebo administration.
2. Subjects will be treated with placebo or inhaled CO at 100 ppm in Cohort 1 and 200 ppm in Cohort 2.
3. After 20 minutes, arterial blood will be drawn for COHb measurement.
4. DLCO will be estimated from the sample taken at 20 minutes using the computer-programmed CFK equation (**Appendix B**).
5. The 90 minute COHb level will be predicted using the CFK equation and compared with the 90 minute measured COHb.
6. Arterial blood will be drawn for COHb measurements at 20 min, 60 min, 75 min, 90 min, and 3 hours (1.5 ml each time point). Arterial blood will be drawn for both ABG analysis and COHb measurement at completion of study drug (2.5 ml).

On days 1-5, a total of approximately 11 ml of arterial blood will be drawn during the study drug administration for safety monitoring of COHb levels, ABG analysis, and measurement of DLCO.

Patients in Cohort 3 will be administered inhaled CO at 200 ppm for 20 minutes as a "test dose" on each study day to determine each subject's algorithm-determined dose. The COHb level will be measured prior to the test dose and 20 minutes after the test dose. These two COHb levels will be used in the CFK equation to determine each subject's specified dose in order to achieve a COHb level of 6-8%. After the

## A Phase I Trial of Inhaled Carbon Monoxide for the Treatment of Sepsis-Induced ARDS

CO dose is determined, subjects will be administered inhaled CO at the algorithm-determined dose- **not to exceed 500 ppm or 90 minutes total (including test dose).**

1. Arterial blood will be drawn for baseline ABG and COHb prior to CO administration (1.5 ml).
2. Subjects will be treated with inhaled CO at 200 ppm for 20 minutes (test dose).
3. After 20 minutes, arterial blood will be drawn for COHb measurement.
4. DLCO will be estimated from the sample taken at 20 minutes using the computer-programmed CFK equation (**Appendix B**).
5. Estimated DLCO will be used to compute the iCO dose to achieve a COHb level of 7% (target 6-8%) at 90 minutes.
6. Dose will be adjusted (200-500 ppm) based on CFK equation-determined dose.
7. Arterial blood will be drawn for COHb measurements at 20 min, 40 min, 60 min, 75 min, 90 min, and 3 hours (0.5 ml each time point). Arterial blood will be drawn for both ABG analysis and COHb measurement at completion of study drug (1.5 ml).

On days 1-5, a total of approximately 5.5 ml of arterial blood will be drawn during the study drug administration for safety monitoring of COHb levels, ABG analysis, measurement of DLCO, and adjustment of study drug dose.

### 5.1.7. Daily Hold Parameters Prior to Study Drug Administration

Subjects will have blood drawn daily for measurement of COHb and lactate prior to administration of study drug. If COHb  $\geq 3\%$  or lactate  $\geq 4$  mmol/L, the study drug will be held until the next scheduled dose the following day. Lactate and COHb will be measured the following day to determine whether the study drug will be administered. If the study drug is being held for another reason, lactate and COHb levels will not be measured on days the study drug is being held.

A 12 lead EKG will also be performed daily prior to study drug administration to evaluate for cardiac exclusion criteria *ie.* acute myocardial infarction or acute coronary syndrome (ACS). If a subject meets the following criteria for ST elevation MI or unstable angina/non ST elevation MI concerning for ACS according to the American College of Cardiology Foundation/American Heart Association guidelines<sup>94-96</sup>, they will be excluded from enrollment or further study drug administration according to exclusion criteria.

ST elevation MI (STEMI) Criteria: New ST elevation at the J point in at least 2 contiguous leads of  $\geq 2$  mm (0.2 mV) in men or  $\geq 1.5$  mm (0.15 mV) in women in leads V2–V3 and/or of  $\geq 1$  mm (0.1mV) in other contiguous chest leads or the limb leads; New or presumably new left bundle branch block (LBBB)<sup>94-96</sup>.

Unstable angina/non ST elevation MI (NSTEMI): Ischemic ST-segment depression  $\geq 0.5$  mm (0.05 mV) or dynamic T-wave inversion with pain or discomfort; Nonpersistent or transient ST-

## A Phase I Trial of Inhaled Carbon Monoxide for the Treatment of Sepsis-Induced ARDS

segment elevation  $\geq 0.5$  mm for  $< 20$  minutes. Threshold values for ST-segment depression consistent with ischemia are J-point depression 0.05 mV (-0.5 mm) in leads V2 and V3 and -0.1 mV (-1 mm) in all other leads (men and women)<sup>94-96</sup>.

Note, troponin (I or T) may be increased in patients with sepsis and ARDS<sup>97</sup> in the absence of an acute MI or ACS from coronary artery disease. If, in the judgment of the clinical team a septic patient with elevated troponin levels has no other indication of an MI or ACS, the patient may still be eligible for enrollment.

In addition, if a subject develops the following criteria during the study, the study drug will be held until resolved:

- Severe hypoxemia defined as  $SpO_2 < 95$  or  $PaO_2 < 80$  on  $FiO_2 \geq 0.8$
- Hemoglobin  $< 7.5$  g/dl or hemoglobin  $< 8$  g/dl and actively bleeding
- Diffuse alveolar hemorrhage from vasculitis
- Use of high frequency ventilation
- Use of inhaled pulmonary vasodilator therapy (eg. NO or prostaglandins)

### 5.1.8. Interruption of Dosing During Study Drug Administration

Subjects will have arterial blood drawn for COHb measurements prior to study drug treatment and 20 min, 40 min, 60 min, 75 min, 90 min, and 3 hours after study drug treatment. It is anticipated that the predicted and achieved COHb in Cohorts 1 and 2 will be well below the target range for Cohort 3 (6-8%) given reductions in CO diffusion in patients with ARDS. However, the following parameters will be used to shorten the 90 minute exposure should CO uptake be higher than anticipated:

#### The study drug will be stopped prior to 90 minutes:

1. If measured COHb  $> 7\%$  at any time during study drug treatment.
2. If COHb is predicted to be  $> 7\%$  prior to 90 minutes. If this occurs, study drug treatment will be stopped at the time the COHb is predicted to be 7% by the CFK equation and an arterial COHb measured at that time.
3. If the investigator, attending physician, the patient, or their surrogate decides that the study drug should be discontinued.

### 5.1.9. Permanent Discontinuation of Study Drug Administration

Permanent discontinuation of the study drug is defined as cessation of the study drug without the intent of restarting the study drug during the five-day treatment period.

#### Permanent discontinuation of the study drug inhalation will occur in the following situations:

- Occurrence of pre-specified administration related adverse events:
  - Acute myocardial infarction within 48 hours of study drug administration
  - Acute cerebrovascular accident (CVA) within 48 hours of study drug administration
  - New onset atrial or ventricular arrhythmia requiring DC cardioversion within 48 hours of study drug administration

## A Phase I Trial of Inhaled Carbon Monoxide for the Treatment of Sepsis-Induced ARDS

- Increased oxygenation requirements defined as: an increase in  $\text{FiO}_2$  of  $\geq 0.2$  **AND** increase in PEEP  $\geq 5$  cm  $\text{H}_2\text{O}$  within 6 hours of study drug administration
- Increase in any protocol specified measurement of COHb  $\geq 10\%$
- Increase in lactate by  $\geq 2$  mmol/L within 6 hours of study drug administration
- If the patient experiences serious adverse events *related to the study drug* (**Section 11** and **Appendix K**)
- If the investigator, attending physician, the patient or their surrogate decides that the study drug should be discontinued. If this decision is made because of an adverse event, then appropriate adverse event reporting procedures will be followed (**Section 11** and **Appendix K**).
- Daily baseline COHb levels greater than 3% leading to three missed drug doses.
- Three or more missed drug administrations due to adverse events.

Patients who have their study drug permanently discontinued will continue their participation in the study, and will be followed to determine their vital status to hospital day 60 or hospital discharge, as outlined in the Time-Events Schedule (**Appendix F**).

### 5.1.10. Completion of Study Drug Administration

Subjects will be considered to have completed the study drug administration portion of the study when one of the following conditions is met, whichever comes first:

1. Five days after study drug administration
2. Discontinuation of mechanical ventilation
3. Completion of one or more doses of study drug
4. Death

The optimal duration of CO therapy for sepsis-induced ARDS is unknown. The decision to examine 5 days of exposure in Phase I was based on trials in healthy volunteers showing skeletal muscle mitochondrial biogenesis activation with no toxicity after a 5 day exposure. Multisystem organ failure is the most common cause of death in patients with ARDS and dysregulated mitochondrial biogenesis has been described in non-survivors of sepsis and may be a key element in the development of organ failure<sup>92</sup>. Thus we chose a 5 day exposure in Phase I to provide more a more complete safety assessment for the anticipated Phase II dosing regimen.

### 5.2. Ventilator Procedures

$\text{FiO}_2$  will be increased prior to study drug administration in order to achieve a  $\text{PaO}_2 \geq 80$  or  $\text{SpO}_2 \geq 95\%$ . Ventilator management, including weaning, will follow the modified ARDS Network lower tidal volume (6 ml/kg PBW) protocol (**Appendix G**)<sup>4</sup>. If not already being utilized, this low tidal volume protocol for mechanical ventilation must be initiated within one hour of randomization. Since the time a patient achieves unassisted ventilation affects a secondary endpoint, VFDs, and because recent evidence-based consensus recommendations have identified a best practice for weaning, weaning strategy will also be controlled by protocol rules in accordance with these evidence-based recommendations. This newer weaning strategy is a simplified version of the protocolized weaning strategy used in prior ARDS Network studies (**Appendix G**). Study drug administration will be continued in patients undergoing weaning from mechanical ventilation as in **Appendix G** unless the subject is deemed ready for extubation by the clinical team. The study drug will not be administered on

the day of planned extubation if the subject has passed a spontaneous awakening trial and spontaneous breathing trial and the clinical team has made the decision for extubation.

## 6. Data Collection

### 6.1. Background Assessments

1. Demographic and Admission Data
2. Pertinent Medical History and Physical Examination
3. Height; gender, measured body weight (MBW); calculated predicted body weight (PBW).
4. Time on ventilator prior to enrollment
5. Type of Admission
  - a. Medical
  - b. Surgical scheduled
  - c. Surgical unscheduled
  - d. Trauma
6. Risk factors for ARDS (sepsis, aspiration, trauma, pneumonia, drug overdose, other)
7. Acute or Chronic renal failure and use of dialysis
8. Presence of the following chronic diseases:
  - a. Metastatic cancer
  - b. Hematological malignancy
  - c. AIDS
  - d. Diabetes Mellitus
  - e. COPD
  - f. Asthma
  - g. Liver cirrhosis
  - h. Hypertension
  - i. Coronary artery disease
  - j. Congestive heart failure
  - k. Peripheral Vascular Disease
  - l. Dementia
  - m. Prior stroke with sequelae
9. Survey of smoking history including:
  - a. Ever smoker (> 100 cigarettes in lifetime)?
  - b. If yes, current smoker?
    - Estimate of pack years (# packs per day) x (# years smoked)
  - c. If former smoker, when did the subject quit smoking?
10. Pregnancy test (serum or urine) for women of childbearing potential

### 6.2. Baseline Assessments

The following information will be recorded during the 24-hour interval preceding initiation of study drug treatment.

If more than one value is available for this 24-hour period, the appropriate values for the APACHE II calculator will be recorded. If no values are available from the 24 hours prior to study drug administration, then values must be measured prior to initiation of study drug.

## A Phase I Trial of Inhaled Carbon Monoxide for the Treatment of Sepsis-Induced ARDS

1. Vital Signs: Heart rate (beats/min), systemic systolic, diastolic, and mean arterial blood pressure (mm Hg), body temperature (°C), and central venous pressure (CVP) if available.
2. Electrocardiogram (EKG)
3. APACHE II Score and SOFA Score
4. Ventilator mode, tidal volume, FiO<sub>2</sub> and PEEP, peak inspiratory pressure, plateau pressure, compliance, minute ventilation, set respiratory rate and total respiratory rate, and mean airway pressure. If on a pressure-cycling mode, peak pressure during inspiration will be assumed to be the plateau pressure.
5. Arterial PaO<sub>2</sub>, PaCO<sub>2</sub>, pH, SpO<sub>2</sub>, and base excess (qualifying arterial blood gas), SpCO, COHb, and ScvO<sub>2</sub> if available
6. Serum CK, AST, ALT, Bilirubin, and Lactate
7. Frontal Chest Radiograph (qualifying radiograph) – radiographic lung injury score (# of quadrants), barotrauma if available
8. Vasopressors or inotropes (epinephrine, norepinephrine, phenylephrine, vasopressin, dopamine, dobutamine, phosphodiesterase inhibitors, including dose)
9. Suspected or known site of infection
10. Fluid intake, fluid output (most recent 24 hour value) or mean hourly value for most recently available period
11. Serum electrolytes, glucose, albumin, and total protein
12. Complete blood count (CBC), prothrombin time (PT), International Normalized Ratio (INR)
13. Glasgow Coma Score
14. Presumed site of infection, if sepsis is the etiology of ARDS.
15. Concomitant medications: Aspirin, Angiotensin converting enzyme inhibitors (ACEIs), Steroids, Statins, Nitroprusside, Methylene blue, Nitrates, Neuromuscular blockade, Inhaled NO or prostaglandins
16. Discarded bronchoalveolar lavage fluid and plasma will be obtained (when available) from the Crimson Biospecimen bank (BWH Biobank which provides discarded samples from consented subjects) for levels of cytokines, mediators, and protein. Plasma and BAL fluid will be divided into equal aliquots in specified tubes, and frozen at -80<sup>0</sup> C.

### 6.3. Assessments after Enrollment

The following data will provide the basis for assessing protocol compliance and safety as well as between-group differences in several efficacy variables. Data for each of the variables will be recorded on the days shown in the Time-Events schedule (**Appendix F**) or until death, discharge from the intensive care unit, or unassisted ventilation for 48 hours.

### Reference Measurements (Days 1 - 5)

The following parameters will be measured and recorded daily on every day of study drug administration from 4:00-10:00 am using the values closest to 8:00 am on the days specified in the Time-Events schedule (**Appendix F**). The following conditions will be ensured prior to measurements: no endobronchial suctioning for 10 minutes; no invasive procedures or ventilator changes for 30 minutes. All vascular pressures will be zero-referenced to the mid-axillary line with the patient supine.

- 1) CO or Placebo Administration- To be collected only on days when study drug is being administered
  - a) Cohort



## A Phase I Trial of Inhaled Carbon Monoxide for the Treatment of Sepsis-Induced ARDS

- b) Dose
- c) Time of administration
- d) COHb and SpCO (0, 20 min, 40 min, 60 min, 75 min, 90 min, 3h after administration)
- e) Tank label and pressures in the tank before and after dose
- f) Safety check
- g) CO ambient levels before and after administration
- 2) Assisted ventilation- record daily up to day 5
  - a) Mode of ventilation, Minute ventilation, Tidal volume, FiO<sub>2</sub>, PEEP, Respiratory Rate, Peak, plateau, and mean airway pressures
  - b) Pressure during inspiration if on a pressure targeted mode (PSV, PCV, etc).
  - c) Arterial PaO<sub>2</sub>, PaCO<sub>2</sub>, pH, base excess, and SaO<sub>2</sub>; if no ABG available, SpO<sub>2</sub>
  - d) Inspiratory flow rate
  - e) End tidal CO<sub>2</sub> (ETCO<sub>2</sub>)- To be collected only on days when study drug is being administered
  - f) Dead space (as measured by NICO, see **Appendix H**) and alveolar ventilation- To be collected only on days when study drug is being administered
- 3) EKG
- 4) Lactate- To be collected only on days when study drug is being administered
- 5) Total Bilirubin
- 6) Arterial Blood Gas before and after study drug administration (according to **Section 5.1.6**)
- 7) Fluid intake and output in the past 24 hours and diuretic administration if applicable
- 8) Renal replacement therapy
- 9) Metabolic panel if available and requested by treating physician
- 10) Serum CK, AST, ALT, Albumin, Total Protein if available and ordered by the treating physician
- 11) Complete blood count (CBC), prothrombin time (PT), International Normalized Ratio (INR) if available and requested by treating physician
- 12) Vital signs: Heart rate, systolic and diastolic blood pressure, body temperature, CVP
- 13) SOFA score daily
  - a) Worst PaO<sub>2</sub>/FiO<sub>2</sub> for that date
  - b) Worst creatinine (or urine output), bilirubin, and platelet count for that date
  - c) Worst Glasgow Coma Scale for that date
  - d) Vasopressor use and maximal dose for that date
- 14) Richmond Agitation Sedation Scale (RASS)
- 15) Frontal Chest Radiograph – radiographic lung injury score (# of quadrants), barotrauma if available
- 16) Vasopressors or inotropes (epinephrine, norepinephrine, phenylephrine, vasopressin, dopamine, dobutamine, phosphodiesterase inhibitors, including dose)
- 17) Concomitant medications: Aspirin, Angiotensin converting enzyme inhibitors (ACEIs), Steroids, Statins, Nitroprusside, Methylene blue, Nitrates, Neuromuscular blockade, Inhaled NO or prostaglandins (Yes/No each day).
- 18) Adverse Event Monitoring (**Section 11** and **Appendix K**)
- 19) Microbiological results when available
  - a) Blood cultures
  - b) Urine cultures
  - c) Sputum cultures
  - d) BAL cultures
  - e) CSF cultures if available

## A Phase I Trial of Inhaled Carbon Monoxide for the Treatment of Sepsis-Induced ARDS

- f) Stool
  - g) Other
- 20) On every day of study drug administration, blood (4 ml) will be collected in EDTA anti-coagulated blood samples for cytokines, mediators, and markers of inflammation. Blood will be collected before and after study drug administration (90 min and 3 hr). Plasma will be obtained and divided immediately after centrifugation into equal aliquots in specified tubes and frozen at  $-80^{\circ}\text{C}$ . Blood for DNA banking by isolation of cell pellets from whole blood (**Appendix I**) will be obtained on every study day.
  - 21) On days 1 (before study drug administration), 3 and 5 (90 min and 3 hr after study drug administration), blood (2.5 ml) for RNA will be collected in Paxgene tubes and frozen at  $-80^{\circ}\text{C}$ .
  - 22) Discarded bronchoalveolar lavage fluid and plasma will be obtained (when available) from the Crimson Biospecimen bank (BWH) on days 1-5 for levels of cytokines, mediators, and protein. Plasma and BAL fluid will be divided into equal aliquots in specified tubes, and frozen at  $-80^{\circ}\text{C}$ .

### Post-Treatment Assessments

#### Day 7

- 1) Assisted ventilation
  - a) Mode of ventilation, Minute ventilation, Tidal volume,  $\text{FiO}_2$ , PEEP, Respiratory Rate, Peak, plateau, and mean airway pressures, compliance
  - b) Pressure during inspiration if on a pressure targeted mode (PSV, PCV, etc).
  - c) Arterial  $\text{PaO}_2$ ,  $\text{PaCO}_2$ , pH, base excess, and  $\text{SaO}_2$ ; if no ABG available,  $\text{SpO}_2$
  - d) Inspiratory flow rate
- 2) EKG
- 3) Lactate if available and requested by treating physician
- 4) Total Bilirubin
- 5) Arterial blood gas
- 6) Renal replacement therapy
- 7) Metabolic panel if available and requested by treating physician
- 8) Serum CK, AST, ALT, Albumin, Total Protein if available and ordered by the treating physician
- 9) Complete blood count (CBC), prothrombin time (PT), International Normalized Ratio (INR) if available and requested by treating physician
- 10) SOFA score
  - a) Worst  $\text{PaO}_2/\text{FiO}_2$  for that date
  - b) Worst creatinine (or urine output), bilirubin, and platelet count for that date
  - c) Worst Glasgow Coma Scale for that date
  - d) Vasopressor use and maximal dose for that date
- 11) Richmond Agitation Sedation Scale (RASS)
- 12) Frontal Chest Radiograph – radiographic lung injury score (# of quadrants), barotrauma if available
- 13) Vasopressors or inotropes (epinephrine, norepinephrine, phenylephrine, vasopressin, dopamine, dobutamine, phosphodiesterase inhibitors, including dose)

## A Phase I Trial of Inhaled Carbon Monoxide for the Treatment of Sepsis-Induced ARDS

- 14) Concomitant medications: Aspirin, Angiotensin converting enzyme inhibitors (ACEIs), Steroids, Statins, Nitroprusside, Methylene blue, Nitrates, Neuromuscular blockade, Inhaled NO or prostaglandins (Yes/No each day).
- 15) Adverse Event Monitoring
- 16) Discarded bronchoalveolar lavage fluid and plasma will be obtained (when available) from the Crimson Biospecimen bank (BWH) on days 1-5 for levels of cytokines, mediators, and protein. Plasma and BAL fluid will be divided into equal aliquots in specified tubes, and frozen at -80° C.

### Day 14

- 1) Assisted ventilation
  - a) Mode of ventilation, Minute ventilation, Tidal volume, FiO<sub>2</sub>, PEEP, Respiratory Rate, Peak, plateau, and mean airway pressures, compliance
  - b) Pressure during inspiration if on a pressure targeted mode (PSV, PCV, etc).
  - c) Arterial PaO<sub>2</sub>, PaCO<sub>2</sub>, pH, base excess, and SaO<sub>2</sub>; if no ABG available, SpO<sub>2</sub>
  - d) Inspiratory flow rate
- 2) SOFA score
  - a) Worst PaO<sub>2</sub>/FiO<sub>2</sub> for that date
  - b) Worst creatinine (or urine output), bilirubin, and platelet count for that date
  - c) Worst Glasgow Coma Scale for that date
  - d) Vasopressor use and maximal dose for that date
- 3) Arterial blood gas
- 4) Vasopressors or inotropes (epinephrine, norepinephrine, phenylephrine, vasopressin, dopamine, dobutamine, phosphodiesterase inhibitors, including dose)
- 5) Renal replacement therapy
- 6) Adverse Event Monitoring if remains in ICU

### Day 28 and 60

Vital Status

Glasgow Coma Scale at Day 28 or on discharge date

Adverse Event Monitoring if remains in ICU

### Day 60

Vital Status

A total of approximately 100 ml of blood will be collected during the study from each study subject as follows:

Before and during study drug administration:

## A Phase I Trial of Inhaled Carbon Monoxide for the Treatment of Sepsis-Induced ARDS

<b>Sample collection</b>	<b>Day 1</b>	<b>Day 2</b>	<b>Day 3</b>	<b>Day 4</b>	<b>Day 5</b>
4 ml EDTA Vacutainer Tube	X	X	X	X	X
2.5 ml Paxgene Tube	X				
5.5 ml for ABG and COHb Analysis	X	X	X	X	X

After study drug administration (90 min and 3 hours):

<b>Sample collection</b>	<b>Day 1</b>	<b>Day 2</b>	<b>Day 3</b>	<b>Day 4</b>	<b>Day 5</b>
4 ml EDTA Vacutainer Tube- 2 tubes	X	X	X	X	X
2.5 ml Paxgene Tube- 2 tubes			X		X

In the case of a study drug hold, blood will only be drawn once and the tubes drawn will be the tubes as indicated in the table below. As blood will only be drawn once on study drug hold days, this will decrease the volume of blood drawn for those subjects.

<b>Sample collection</b>	<b>Day 1</b>	<b>Day 2</b>	<b>Day 3</b>	<b>Day 4</b>	<b>Day 5</b>
4 ml EDTA Vacutainer Tube- 2 tubes	X	X	X	X	X
2.5 ml Paxgene Tube- 2 tubes	X		X		X

Samples will be sent to a central repository to be stored (as described below). Central repository accession numbers will identify samples during shipment and storage in the central repository. In the future, the data coordinating center (DCC) will instruct the repository to prepare the appropriate samples for shipment. The key relating the subject study ID number to the new specimen accession number will be kept at the DCC in a restricted access electronic file. The DCC will not record or store unique patient identifiers (such as initials, date of birth, hospital record numbers, addresses, phone numbers, etc.) in the database. All data released by the DCC for studies will be linked to the specimen but will be de-identified. The link (key) between the de-identified database and the patient will be removed two years after the primary publication. Samples collected for this trial will be frozen and stored at a biorepository for future research.

### 6.4. Assessments after Hospitalization

Vital status will be collected at 28 and 60 days through telephone interviews with patients. Surrogates will be contacted in the case that patients cannot be reached. In addition, we will verify duration of survival for patients lost to follow-up or noted to have died using the Centers for Disease Control and Prevention's National Death Index (National Death Index, 2000). We will use each patient's social security number (SSN) for an exact NDI match. We will collect contact information for the patient and alternative contact information on up to 3 individuals. This information and the SSN will be collected on paper at the time of consent, and forwarded via secure fax to the DCC. Contact information and SSN will be maintained on paper and will not appear in the DCC database.

Long term cognitive function will not be assessed in this Phase 1 study due to multiple confounding factors. Cognitive impairment is highly prevalent among survivors of critical illness<sup>98-103</sup>. In addition, neurocognitive deficits observed at three months after hospitalization persist at 12 months following

critical illness in the majority of patients<sup>103</sup>. In survivors of ARDS, cognitive impairment has been observed in approximately 30-55% of patients following one year of hospitalization<sup>98,102</sup>. Similarly, moderate to severe cognitive impairment has been observed in survivors of severe sepsis up to one year following hospitalization<sup>99</sup>.

Furthermore, several studies have demonstrated the safety of CO, including lack of adverse neurocognitive effects, at levels of COHb <10%, which exceed the levels anticipated in our study. Neurocognitive effects of CO have been extensively evaluated in previous human studies<sup>81,104</sup>, our endotoxin study in healthy volunteers (NCT00094406), and our recent trial of CO treatment in IPF patients (NCT01214187). Stewart et al. demonstrated no impairment in performance testing in healthy humans exposed to CO at 100 ppm for 8 hours with COHb levels of 11-13%<sup>81</sup>. In addition, we demonstrated lack of adverse neurocognitive effects in healthy volunteers exposed to CO at 100 ppm for 6 hours with COHb 6.5% ± 1.7%. In addition, a recent study by Linde Gas Therapeutics assessed the safety of inhaled CO in 32 healthy subjects. CO was well tolerated with no significant neurocognitive effects observed in subjects with COHb levels of 2-8.8% (**Appendix N**). Furthermore, we recently evaluated neurocognitive function in subjects enrolled in our CO IPF trial using the Montreal Cognitive Assessment tool. Subjects with IPF receiving biweekly treatment with inhaled CO at 100-200 ppm for 2 hours demonstrated no impairment in neurocognitive function after 2.5 weeks of follow-up (**Appendix M**). In addition to these studies, a recent review of the literature suggests that neurocognitive effects are only seen once COHb rises above 15-20%<sup>104</sup>.

In addition, this Phase 1 dose-finding and safety trial is not powered to see differences in outcomes. Should this treatment proceed to a Phase 2 study, it will be powered to allow for a direct assessment of the incremental risk, if any, of carbon monoxide inhalation on cognitive function in patients with sepsis and ARDS.

## 6.5. Endpoint Determinations

1. Vital status at 60 days until discharged home on unassisted breathing
2. Time of initiation of unassisted breathing (assuming a patient achieves 48 consecutive hours of unassisted breathing)
3. Need for re-instituting assisted or mechanical ventilation after achieving 48 consecutive hours of unassisted breathing
4. Need for, timing, and duration of dialysis
5. Vital status 48 hours after initiation of unassisted breathing
6. ICU length of stay in calendar days including ICU days after readmission to ICU
7. Hospital length of stay in calendar days and discharge disposition (home, other facility, with or without assisted ventilation)
8. Administration associated adverse events (**Section 5.1.9.**)
9. All adverse events

## 7. Statistical Considerations and Safety Assessment

### 7.1. Statistical Considerations

For this phase I safety trial, any patient who is randomized and receives a portion of any dose of treatment will be included in the primary safety analysis. Baseline demographics and clinical

characteristics will be summarized descriptively overall and by group. The primary endpoint of this Phase I trial is safety of inhaled CO, defined by the incidence of pre-specified CO-administration associated adverse events and severe adverse events. All safety data and on-study vital signs will be summarized descriptively for each treatment group. Although the study is not powered to demonstrate significant differences in secondary endpoints, numerical secondary outcomes will be compared between two groups using either Student's t tests or Mann-Whitney U tests. Categorical secondary outcomes will be compared using either chi-square ( $\chi^2$ ) test or Fisher's exact test. All statistical analyses will be performed using SAS v 9.4 or newer versions (Cary, NC) or equivalent statistical packages.

For secondary and exploratory endpoints, analyses may be limited to subjects who have met the criteria for study drug completion as per Section 5.1.10. Subjects who have not met the criteria for study drug completion (as per Section 5.1.10) may be analyzed separately.

For secondary and exploratory endpoints, subjects may also be analyzed according to number of study drug doses completed.

## 7.2. Phase I Safety Assessment

The Scientific Review Committee (SRC, **Appendix J**) will independently review the safety data within 14 days after the last enrolled subject in each cohort has completed the study drug, and make recommendations to the DSMB. In addition, site investigators will notify the DCC of any severe unexpected adverse event (**Appendix K**) within 24 hours of becoming aware of the event. The DCC will review all reported events and report all serious, unexpected, and study-related adverse events and all "administration related adverse events" to the SRC for review and input by email or telephone prior to submission to the DSMB within 7 calendar days of the DCC being notified of the event. The decision about whether the frequency of adverse events is too high will not have formal evaluation criteria. The DSMB will be provided with summary statistics of baseline and on-study vital signs and laboratory values as well as tabulations of all the study endpoints.

## 7.3. Summary Guidelines for SRC and DSMB Assessment

The SRC and DSMB will meet following completion of subjects within each cohort. The DSMB will perform a safety evaluation and make the decision whether to proceed with the next cohort. **The DSMB will make a recommendation to either: proceed to the next cohort; add additional subjects to a given cohort; or terminate the study.** Recommendations by the SRC or DSMB to add additional subjects to a cohort will be reviewed by the Institutional Review Board (IRB) of each study hospital prior to enrollment of additional subjects. **The SRC and DSMB may halt enrollment in the study at any time during the trial.**

### 7.3.1. Decision to Proceed to Cohort 2

A decision to proceed to Cohort 2 using 200 ppm of inhaled CO will be made by the DSMB after review of safety data obtained up to 14 days from the last dose in the last patient in Cohort 1.

### 7.3.2. Decision to Proceed to Cohort 3

A decision to proceed to Cohort 3 using algorithm-specified inhaled CO dose (to achieve COHb of 6-8%) will be made by the DSMB after review of safety data obtained up to 14 days from the last dose in

the last patient in Cohort 2.

These are guidelines for decision-making. The SRC and DSMB may elect to terminate the study based on the nature and seriousness of infrequent adverse events.

## **8. Data Collection and Site Monitoring**

### **8.1. Data Collection**

Study coordinators will collect data and enter it directly into the web-based data entry system managed by the Data Coordinating Center or record on paper data forms. Data will be transferred to the DCC on a prescribed basis through a web-based data entry program.

### **8.2. Site Monitoring**

Site visits will be performed on a regular basis by the DCC, to ensure that all regulatory requirements are met and to monitor the quality of the data collected. Records of Institutional Review Board approvals and patients' charts will be examined on a spot check basis to evaluate the accuracy of the data entered into the database.

## **9. Risk Assessment**

### **9.1. Risks of Active Study Drug**

Potential risks of active study drug include headache and tachycardia. In cases of overdose, patients can have nausea, vomiting, seizures, problems thinking, coma, cardiopulmonary arrest, and death. These adverse effects are seen at doses much higher than those proposed in this study. Subjects will be vigilantly monitored for side effects during drug administration and COHb and lactate levels will be carefully monitored as outlined in the Study Protocol. There may be other risks of inhaled CO in patients with ARDS that are currently unknown. Subjects will be monitored closely throughout their participation in the trial.

### **9.2. Risks of blood draws**

All patients will have blood drawn for research purposes. Most blood will be drawn through indwelling catheters. Risks of drawing blood percutaneously are uncommon and include bleeding and bruising.

### **9.3. Minimization of Risks**

Federal regulations at 45 CFR 46.111(a) (1) requires that risks to subjects are minimized by using procedures which are consistent with sound research design. There are several elements of study design in the present protocol that meets this human subject protection requirement. First, several of the exclusion criteria prohibit participation of patients who might be at increased risk from the effects of CO as outlined in **Section 4.3.**) These include individuals with severe hypoxemia, acute myocardial infarction or acute coronary syndrome within 90 days, angina pectoris with activities of daily living, cardiopulmonary disease (NYHA class IV), CVA within 3 months, as well as women who are pregnant or breast feeding.

Second, to limit risk of toxicity during drug administration, we will:

1. Monitor inhaled CO concentrations via the CO analyzer in the CO Delivery System during drug administration.
2. Perform serial bedside measurements of arterial COHb at 20, 40, 60, 75, and 90 minutes during study drug administration as well as 3 hours after treatment.
3. Measure SpCO at the same time points throughout the study.
4. Use the CFK equation to predict increases in COHb for a given study drug concentration and exposure duration.

Third, there are provisions in the protocol for daily hold parameters, interruption of dosing, and permanent discontinuation of the study drug. As well, in Cohort 3, there are provisions in the protocol for dosage adjustment based on the predicted 90 minute COHb using the CFK equation. Fourth, we will monitor for adverse effects by monitoring baseline COHb and lactate prior to each dose. We will not administer the study drug if COHb  $\geq 3\%$  or lactate  $\geq 4$  mmol/L.

Finally, the SRC and DSMB will meet after completion of each cohort for safety evaluation before proceeding to the next cohort.

#### **9.4. Potential Benefits**

Study subjects may or may not receive any direct benefits from their participation in this study. Potential benefits from the administration of CO include decreased requirement for ventilatory support, decreased days spent in the ICU, increased organ failure free days, and enhanced survival. Finally, there are potential benefits to society since the discovery of agents that can reduce the substantial mortality and morbidity of ARDS would enhance the health of society.

#### **9.5. Risks versus Benefits**

Federal regulations at 45 CFR 46. 111 (a)(2) require that “the risks to subjects are reasonable in relation to anticipated benefits, if any, to subjects, and the importance of the knowledge that may reasonably be expected to result.” Based on the preceding assessment of risks and potential benefits, the risks to subjects are reasonable in relation to anticipated benefits.

Blood draws: The risks associated with this common clinical practice are small, however, the knowledge gained in furthering our understanding of the pathophysiology and potentially leading to better and targeted therapy may be substantial.

CO Treatment: Although there is a risk of toxicity associated with inhalation of high concentrations of CO, low dose inhaled CO has been shown to be protective in animal models and safe in humans. Data from animal studies demonstrate that inhaled CO has beneficial effects on outcomes in sepsis and ALI. There is potential for benefit to society and individual patients should treatment prove to be of benefit for future patients with ARDS.

## **10. Human Subjects**

Each study participant or a legally authorized representative must sign and date an informed consent form. Institutional review board approval will be required before any subject is entered into the study.



## **10.1. Selection of Subjects**

### **10.1.1. Equitable Selection of Subjects**

Federal regulations at 45 CFR 46(a)(3) require the equitable selection of subjects. The ICUs will be screened to determine if any patient meets the inclusion and exclusion criteria. Data that have been collected as part of the routine management of the subject will be reviewed to determine eligibility. No protocol-specific tests or procedures will be performed as part of the screening process. If any subjects meet criteria for study enrollment, then the attending physician will be asked for permission to approach the patient or his/her surrogate for informed consent. Justifications of exclusion criteria are given in **Section 4.3**. These exclusion criteria neither unjustly exclude classes of individuals from participation in the research nor unjustly include classes of individuals from participation in the research. Hence, the recruitment of subjects conforms to the principle of distributive justice.

### **10.1.2. Justification of Including Vulnerable Subjects**

The present research aims to investigate the safety of a type of treatment for patients with sepsis-induced ARDS. Due to the nature of these illnesses, the vast majority of these patients will have impaired decision-making capabilities. This study cannot be conducted if enrollment is limited to only those subjects with decision-making capacity. Potential benefits to participation in this study are increased survival and VFDs.

## **10.2. Informed Consent**

Federal regulations 45 CFR 46.111(a)(5) require that informed consent will be sought from each prospective subject or the subject's legally authorized representative. The investigator is responsible for ensuring that the patient understands the risks and benefits of participating in the study, and answering any questions the patient may have throughout the study and sharing any new information in a timely manner that may be relevant to the patient's willingness to continue his or her participation in the trial. All study participants or their surrogates will be informed of the objectives of the study and the potential risks. The informed consent document will be used to explain the risks and benefits of study participation to the patient in simple terms before the patient is entered into the study, and to document that the patient is satisfied with his or her understanding of the risks and benefits of participating in the study and desires to participate in the study. The investigator is responsible for ensuring that informed consent is given by each patient or legal representative. This includes obtaining the appropriate signatures and dates on the informed consent document prior to the performance of any protocol procedures and prior to the administration of study agent.

## **10.3. Continuing Consent**

For subjects for whom consent was initially obtained from a surrogate, but who subsequently regain decision-making capacity while in hospital, we will obtain formal consent for continuing participation, inclusive of continuance of data acquisition. The initial consent form signed by the surrogate will reflect that such continuing consent will be obtained when possible.

## **10.4. Identification of Surrogates**

Many of the patients approached for participation in this research protocol will have limitations of

decision-making abilities due to their critical illness. Hence, most patients will not be able to provide informed consent. Accordingly, informed consent will be sought from the potential subject's legally authorized representative. Regarding proxy consent, the existing federal research regulations ('the Common Rule') state at 45 CFR 46.116 that "no investigator may involve a human being as a subject in research...unless the investigator has obtained the legally effective informed consent of the subject or the subject's legally authorized representative"; and defines at 45 CFR 46 102 (c) a legally authorized representative (LAR) as "an individual or judicial or other body authorized under applicable law to consent on behalf of a prospective subject to the subject's participation in the procedures(s) involved in the research." OHRP defined examples of "applicable law" as being state statutes, regulations, case law, or formal opinion of a State Attorney General that addresses the issue of surrogate consent to medical procedures. Such "applicable law" could then be considered as empowering the surrogate to provide consent for subject participation in the research. Interpretation of "applicable law" is therefore state specific and hence, will be left to the discretion of the individual IRBs of the respective clinical centers involved in the study.

According to a previous President's Bioethics Committee (National Bioethics Advisory Committee), an investigator should accept as an LAR...a relative or friend of the potential subject who is recognized as an LAR for purposes of clinical decision making under the law of the state where the research takes place<sup>105</sup>. Finally, OHRP has opined in their determination letters that a surrogate could serve as a LAR for research decision making if such an individual is authorized under applicable state law to provide consent for the "procedures" involved in the research study<sup>106</sup>.

### **10.5. Justification of Surrogate Consent**

According to the Belmont Report, respect for persons incorporates at least two ethical convictions; first, that individuals should be treated as autonomous agents, and second, that persons with diminished autonomy are entitled to protection. One method that serves to protect subjects is restrictions on the participation of subjects in research that presents more than minimal risks. Commentators and Research Ethics Commission have held the view that it is permissible to include incapable subjects in research that involves more than minimal risk as long as there is the potential for beneficial effects and if the research presents a balance of risks and expected direct benefits similar to that available in the clinical setting<sup>107</sup>. Several U.S. task forces have deemed it is permissible to include incapable subjects in research. For example, the American College of Physicians' document allows surrogates to consent to research involving incapable subjects only "if the net additional risks of participation are not substantially greater than the risks of standard treatment<sup>108</sup>." Finally, the National Bioethics Advisory Committee (NBAC) stated that an IRB may approve a protocol that presents greater than minimal risk but offers the prospect of direct medical benefits to the subject, provided that...the potential subject's LAR gives permission...<sup>105</sup>.

### **10.6. Additional Safeguards for Vulnerable Subjects**

The present research will involve subjects who might be vulnerable to coercion or undue influence. As required in 45CFR46.111(b), we recommend that additional safeguards be included to protect the rights and welfare of these subjects. Such safeguards might include, but are not limited to: a) assessment of the potential subject's capacity to provide informed consent, b) requirement for subject's assent, c) the availability of the LAR to monitor the subject's subsequent participation and withdrawal from the study, and d) augmented consent processes. The specific nature of the additional safeguards will be left to the discretion of the individual IRBs.

## 10.7. Confidentiality

All subjects or surrogates must provide written informed consent and signed HIPAA authorization prior to the performance of any screening or main study procedures. Federal regulations at 45 CFR 46 111 (a) (7) requires that when appropriate, there are adequate provisions to protect the privacy of subjects and to maintain the confidentiality of data. Subject confidentiality will be protected throughout the study and no subject-identifying information will be released to anyone outside the study. Confidentiality will be secured through several mechanisms. To maintain confidentiality, all laboratory specimens, evaluation forms, and reports will be identified only by a coded number. The coded number will be generated at random by a computer, and only the study investigators will have access to the codes. All records will be kept in a locked, password protected computer. All computer entry and networking programs will be done with coded numbers only. Any study forms and paper records containing personal identifier information (e.g., address, phone number) will be kept secured and locked at each clinical center. No personal identifiers will be placed on biological samples and other documents forwarded to central labs. All paper case report forms will be maintained in a locked cabinet inside a locked office. No personal identifiers, such as name, address, or social security number will be entered into the study database. Any subject-specific data reported to any study committees will only be identified by subject ID number. Access to all subject data and information at the clinical centers, including biological samples, will be restricted to authorized personnel. Finally, subjects will not be identified by name in any reports or publications, nor will the data be presented in such a way that the identity of individual subjects can be inferred. Analysis files created for further study by the scientific community will have no subject identifiers. Clinical information will not be released without the written permission of the patient, except as necessary for monitoring by the National Heart, Lung, and Blood Institute, the Federal Drug Administration or other authorized Federal Agencies, local IRBs, and the Data Coordinating Center.

## 11. Adverse Event Reporting

Investigators will determine daily if any clinical adverse events occur during the period from enrollment to ICU discharge as described in Appendix K. An *adverse event* is any untoward medical occurrence associated with the use of a drug, whether or not considered drug related. The investigator will evaluate any changes in laboratory values and physical signs and will determine if these changes are clinically important. All clinically important adverse events will be recorded in the case report form regardless of attribution to study drug.

**For this trial, a subset of adverse events will be considered to be “administration related adverse events”.** These "administration related adverse events" will by definition be considered suspected adverse reactions, as outlined in Appendix K. These events are:

- New onset atrial or ventricular arrhythmias requiring DC cardioversion within 48 hours of study drug administration
- Myocardial infarction within 48 hours of study drug administration
- CVA within 48 hours of study drug administration
- Increase in O<sub>2</sub> requirements defined as: an increase in FiO<sub>2</sub> of  $\geq 0.2$  **AND** increase in PEEP  $\geq 5$  cm H<sub>2</sub>O within 6 hours of study drug administration
- Increase in lactate by 2 mmol/L within 6 hours of study drug administration
- Increase in any protocol specified measurement of COHb  $\geq 10\%$

## A Phase I Trial of Inhaled Carbon Monoxide for the Treatment of Sepsis-Induced ARDS

Investigators will report all **serious AND unexpected adverse events or reactions**, as defined in **Appendix K**, as well as serious AND “administration related adverse events” as described above, to the DCC by phone, fax or email within 24 hours of becoming aware of the event. The DCC will review the event and may inform the site to permanently discontinue study drug administration to the subject (**Section 5.1.9.**), and may hold enrollment pending SRC and DSMB review (**Section 7.3.**). The local Institutional Review Boards will also be notified according to local requirements. The investigator will then submit a detailed written report to the DCC and the Institutional Review Board no later than 5 calendar days after the investigator discovers the event.

The DCC will report all unexpected and study-related deaths or life-threatening suspected serious adverse events to the FDA within 7 days. The DCC will report all deaths occurring during the study hospitalization and all serious, unexpected, and study-related adverse events and all administration related adverse events to the DSMB, by email, or telephone, within 7 calendar days of the DCC being notified of the event. A written report will be sent to the DSMB and the FDA within 15 calendar days, and these reports will be sent to investigators for submission to their respective Institutional Review Boards. The DSMB will also review all adverse events during scheduled interim analyses. The DCC will distribute the written summary of the DSMB’s periodic review of adverse events to investigators for submission to their respective Institutional Review Boards in accordance with NIH guidelines.

Investigators must also report Unanticipated Problems, regardless of severity, associated with the study drug or study procedures within 24 hours. An unanticipated problem is defined as follows: **Unanticipated Problem (UP)**: any incident, experience, or outcome that meets all of the following criteria:

- Unexpected, in terms of nature, severity, or frequency, given the research procedures that are described in the protocol-related documents, such as the IRB-approved research protocol and informed consent document; and the characteristics of the subject population being studied;
- Related or possibly related to participation in the research, in this guidance document, possibly related means there is a reasonable possibility that the incident, experience, or outcome may have been caused by the procedures involved in the research;
- Suggests that the research places subjects or others at a greater risk of harm (including physical, psychological, economic, or social harm) than was previously known or recognized.

## 12. References

1. Singer M, Deutschman CS, Seymour CW, et al. The Third International Consensus Definitions for Sepsis and Septic Shock (Sepsis-3). *JAMA* 2016;315:801-10.
2. Rubenfeld GD, Caldwell E, Peabody E, et al. Incidence and outcomes of acute lung injury. *N Engl J Med* 2005;353:1685-93.
3. Ware LB, Matthay MA. The acute respiratory distress syndrome. *N Engl J Med* 2000;342:1334-49.
4. The Acute Respiratory Distress Syndrome Network. Ventilation with lower tidal volumes as compared with traditional tidal volumes for acute lung injury and the acute respiratory distress syndrome. *N Engl J Med* 2000;342:1301-8.
5. Angus DC, Linde-Zwirble WT, Lidicker J, Clermont G, Carcillo J, Pinsky MR. Epidemiology of severe sepsis in the United States: analysis of incidence, outcome, and associated costs of care. *Crit Care Med* 2001;29:1303-10.
6. Angus DC, Wax RS. Epidemiology of sepsis: an update. *Crit Care Med* 2001;29:S109-16.
7. Hotchkiss RS, Karl IE. The pathophysiology and treatment of sepsis. *N Engl J Med* 2003;348:138-50.
8. Morse D, Choi AM. Heme oxygenase-1: from bench to bedside. *Am J Respir Crit Care Med* 2005;172:660-70.
9. Otterbein LE, Choi AM. Heme oxygenase: colors of defense against cellular stress. *Am J Physiol Lung Cell Mol Physiol* 2000;279:L1029-37.
10. Otterbein LE, Mantell LL, Choi AM. Carbon monoxide provides protection against hyperoxic lung injury. *Am J Physiol* 1999;276:L688-94.
11. Otterbein LE, Otterbein SL, Ifedigbo E, et al. MKK3 mitogen-activated protein kinase pathway mediates carbon monoxide-induced protection against oxidant-induced lung injury. *Am J Pathol* 2003;163:2555-63.
12. Otterbein LE, Bach FH, Alam J, et al. Carbon monoxide has anti-inflammatory effects involving the mitogen-activated protein kinase pathway. *Nat Med* 2000;6:422-8.
13. Brouard S, Otterbein LE, Anrather J, et al. Carbon monoxide generated by heme oxygenase 1 suppresses endothelial cell apoptosis. *J Exp Med* 2000;192:1015-26.
14. Zhang X, Shan P, Alam J, Davis RJ, Flavell RA, Lee PJ. Carbon monoxide modulates Fas/Fas ligand, caspases, and Bcl-2 family proteins via the p38alpha mitogen-activated protein kinase pathway during ischemia-reperfusion lung injury. *J Biol Chem* 2003;278:22061-70.
15. Song R, Mahidhara RS, Liu F, Ning W, Otterbein LE, Choi AM. Carbon monoxide inhibits human airway smooth muscle cell proliferation via mitogen-activated protein kinase pathway. *Am J Respir Cell Mol Biol* 2002;27:603-10.
16. Zhou Z, Song R, Fattman CL, et al. Carbon monoxide suppresses bleomycin-induced lung fibrosis. *Am J Pathol* 2005;166:27-37.
17. Fujita T, Toda K, Karimova A, et al. Paradoxical rescue from ischemic lung injury by inhaled carbon monoxide driven by derepression of fibrinolysis. *Nat Med* 2001;7:598-604.
18. Chung SW, Liu X, Macias AA, Baron RM, Perrella MA. Heme oxygenase-1-derived carbon monoxide enhances the host defense response to microbial sepsis in mice. *J Clin Invest* 2008;118:239-47.
19. Lee S, Lee SJ, Coronata AA, et al. Carbon monoxide confers protection in sepsis by enhancing beclin 1-dependent autophagy and phagocytosis. *Antioxid Redox Signal* 2014;20:432-42.
20. Chiang N, Shinohara M, Dalli J, et al. Inhaled carbon monoxide accelerates resolution of inflammation via unique proresolving mediator-heme oxygenase-1 circuits. *J Immunol* 2013;190:6378-88.

## A Phase I Trial of Inhaled Carbon Monoxide for the Treatment of Sepsis-Induced ARDS

21. MacGarvey NC, Suliman HB, Bartz RR, et al. Activation of mitochondrial biogenesis by heme oxygenase-1-mediated NF-E2-related factor-2 induction rescues mice from lethal *Staphylococcus aureus* sepsis. *Am J Respir Crit Care Med* 2012;185:851-61.
22. Dolinay T, Szilasi M, Liu M, Choi AM. Inhaled carbon monoxide confers antiinflammatory effects against ventilator-induced lung injury. *Am J Respir Crit Care Med* 2004;170:613-20.
23. Hoetzel A, Dolinay T, Vallbracht S, et al. Carbon monoxide protects against ventilator-induced lung injury via PPAR-gamma and inhibition of Egr-1. *Am J Respir Crit Care Med* 2008;177:1223-32.
24. Hoetzel A, Schmidt R, Vallbracht S, et al. Carbon monoxide prevents ventilator-induced lung injury via caveolin-1. *Crit Care Med* 2009;37:1708-15.
25. Kohmoto J, Nakao A, Kaizu T, et al. Low-dose carbon monoxide inhalation prevents ischemia/reperfusion injury of transplanted rat lung grafts. *Surgery* 2006;140:179-85.
26. Kohmoto J, Nakao A, Stolz DB, et al. Carbon monoxide protects rat lung transplants from ischemia-reperfusion injury via a mechanism involving p38 MAPK pathway. *Am J Transplant* 2007;7:2279-90.
27. Zhang X, Shan P, Otterbein LE, et al. Carbon monoxide inhibition of apoptosis during ischemia-reperfusion lung injury is dependent on the p38 mitogen-activated protein kinase pathway and involves caspase 3. *J Biol Chem* 2003;278:1248-58.
28. Morse D, Pischke SE, Zhou Z, et al. Suppression of inflammatory cytokine production by carbon monoxide involves the JNK pathway and AP-1. *J Biol Chem* 2003;278:36993-8.
29. Sarady JK, Zuckerbraun BS, Bilban M, et al. Carbon monoxide protection against endotoxic shock involves reciprocal effects on iNOS in the lung and liver. *FASEB J* 2004;18:854-6.
30. Zuckerbraun BS, McCloskey CA, Gallo D, et al. Carbon monoxide prevents multiple organ injury in a model of hemorrhagic shock and resuscitation. *Shock* 2005;23:527-32.
31. Zuckerbraun BS, Chin BY, Wegiel B, et al. Carbon monoxide reverses established pulmonary hypertension. *J Exp Med* 2006;203:2109-19.
32. Christou H, Morita T, Hsieh CM, et al. Prevention of hypoxia-induced pulmonary hypertension by enhancement of endogenous heme oxygenase-1 in the rat. *Circ Res* 2000;86:1224-9.
33. Minamino T, Christou H, Hsieh CM, et al. Targeted expression of heme oxygenase-1 prevents the pulmonary inflammatory and vascular responses to hypoxia. *Proc Natl Acad Sci U S A* 2001;98:8798-803.
34. Yet SF, Perrella MA, Layne MD, et al. Hypoxia induces severe right ventricular dilatation and infarction in heme oxygenase-1 null mice. *J Clin Invest* 1999;103:R23-9.
35. Kim HP, Wang X, Nakao A, et al. Caveolin-1 expression by means of p38beta mitogen-activated protein kinase mediates the antiproliferative effect of carbon monoxide. *Proc Natl Acad Sci U S A* 2005;102:11319-24.
36. Otterbein LE, Zuckerbraun BS, Haga M, et al. Carbon monoxide suppresses arteriosclerotic lesions associated with chronic graft rejection and with balloon injury. *Nat Med* 2003;9:183-90.
37. Raman KG, Barbato JE, Ifedigbo E, et al. Inhaled carbon monoxide inhibits intimal hyperplasia and provides added benefit with nitric oxide. *J Vasc Surg* 2006;44:151-8.
38. Ramlawi B, Scott JR, Feng J, et al. Inhaled carbon monoxide prevents graft-induced intimal hyperplasia in swine. *J Surg Res* 2007;138:121-7.
39. True AL, Olive M, Boehm M, et al. Heme oxygenase-1 deficiency accelerates formation of arterial thrombosis through oxidative damage to the endothelium, which is rescued by inhaled carbon monoxide. *Circ Res* 2007;101:893-901.
40. Akamatsu Y, Haga M, Tyagi S, et al. Heme oxygenase-1-derived carbon monoxide protects hearts from transplant associated ischemia reperfusion injury. *FASEB J* 2004;18:771-2.

41. Faleo G, Neto JS, Kohmoto J, et al. Carbon monoxide ameliorates renal cold ischemia-reperfusion injury with an upregulation of vascular endothelial growth factor by activation of hypoxia-inducible factor. *Transplantation* 2008;85:1833-40.
42. Kaizu T, Ikeda A, Nakao A, et al. Protection of transplant-induced hepatic ischemia/reperfusion injury with carbon monoxide via MEK/ERK1/2 pathway downregulation. *Am J Physiol Gastrointest Liver Physiol* 2008;294:G236-44.
43. Nakao A, Faleo G, Nalesnik MA, Seda-Neto J, Kohmoto J, Murase N. Low-dose carbon monoxide inhibits progressive chronic allograft nephropathy and restores renal allograft function. *Am J Physiol Renal Physiol* 2009;297:F19-26.
44. Nakao A, Kimizuka K, Stolz DB, et al. Carbon monoxide inhalation protects rat intestinal grafts from ischemia/reperfusion injury. *Am J Pathol* 2003;163:1587-98.
45. Nakao A, Toyokawa H, Abe M, et al. Heart allograft protection with low-dose carbon monoxide inhalation: effects on inflammatory mediators and alloreactive T-cell responses. *Transplantation* 2006;81:220-30.
46. Neto JS, Nakao A, Kimizuka K, et al. Protection of transplant-induced renal ischemia-reperfusion injury with carbon monoxide. *Am J Physiol Renal Physiol* 2004;287:F979-89.
47. Sato K, Balla J, Otterbein L, et al. Carbon monoxide generated by heme oxygenase-1 suppresses the rejection of mouse-to-rat cardiac transplants. *J Immunol* 2001;166:4185-94.
48. Song R, Kubo M, Morse D, et al. Carbon monoxide induces cytoprotection in rat orthotopic lung transplantation via anti-inflammatory and anti-apoptotic effects. *Am J Pathol* 2003;163:231-42.
49. Mitchell LA, Channell MM, Royer CM, Ryter SW, Choi AM, McDonald JD. Evaluation of inhaled carbon monoxide as an anti-inflammatory therapy in a nonhuman primate model of lung inflammation. *Am J Physiol Lung Cell Mol Physiol* 2010;299:L891-7.
50. Boutros C, Zegdi R, Lila N, et al. Carbon monoxide can prevent acute lung injury observed after ischemia reperfusion of the lower extremities. *J Surg Res* 2007;143:437-42.
51. Mishra S, Fujita T, Lama VN, et al. Carbon monoxide rescues ischemic lungs by interrupting MAPK-driven expression of early growth response 1 gene and its downstream target genes. *Proc Natl Acad Sci U S A* 2006;103:5191-6.
52. Scott JR, Cukiernik MA, Ott MC, et al. Low-dose inhaled carbon monoxide attenuates the remote intestinal inflammatory response elicited by hindlimb ischemia-reperfusion. *Am J Physiol Gastrointest Liver Physiol* 2009;296:G9-G14.
53. Nakao A, Moore BA, Murase N, et al. Immunomodulatory effects of inhaled carbon monoxide on rat syngeneic small bowel graft motility. *Gut* 2003;52:1278-85.
54. Goebel U, Mecklenburg A, Siepe M, et al. Protective effects of inhaled carbon monoxide in pig lungs during cardiopulmonary bypass are mediated via an induction of the heat shock response. *Br J Anaesth* 2009;103:173-84.
55. Goebel U, Siepe M, Mecklenburg A, et al. Reduced pulmonary inflammatory response during cardiopulmonary bypass: effects of combined pulmonary perfusion and carbon monoxide inhalation. *Eur J Cardiothorac Surg* 2008;34:1165-72.
56. Goebel U, Siepe M, Mecklenburg A, et al. Carbon monoxide inhalation reduces pulmonary inflammatory response during cardiopulmonary bypass in pigs. *Anesthesiology* 2008;108:1025-36.
57. Lavitrano M, Smolenski RT, Musumeci A, et al. Carbon monoxide improves cardiac energetics and safeguards the heart during reperfusion after cardiopulmonary bypass in pigs. *FASEB J* 2004;18:1093-5.
58. Piantadosi CA, Carraway MS, Babiker A, Suliman HB. Heme oxygenase-1 regulates cardiac mitochondrial biogenesis via Nrf2-mediated transcriptional control of nuclear respiratory factor-1. *Circ Res* 2008;103:1232-40.

## A Phase I Trial of Inhaled Carbon Monoxide for the Treatment of Sepsis-Induced ARDS

59. Suliman HB, Carraway MS, Ali AS, Reynolds CM, Welty-Wolf KE, Piantadosi CA. The CO/HO system reverses inhibition of mitochondrial biogenesis and prevents murine doxorubicin cardiomyopathy. *J Clin Invest* 2007;117:3730-41.
60. Ameredes BT, Otterbein LE, Kohut LK, Gligonic AL, Calhoun WJ, Choi AM. Low-dose carbon monoxide reduces airway hyperresponsiveness in mice. *Am J Physiol Lung Cell Mol Physiol* 2003;285:L1270-6.
61. Chapman JT, Otterbein LE, Elias JA, Choi AM. Carbon monoxide attenuates aeroallergen-induced inflammation in mice. *Am J Physiol Lung Cell Mol Physiol* 2001;281:L209-16.
62. Pamplona A, Ferreira A, Balla J, et al. Heme oxygenase-1 and carbon monoxide suppress the pathogenesis of experimental cerebral malaria. *Nat Med* 2007;13:703-10.
63. Tsui TY, Obed A, Siu YT, et al. Carbon monoxide inhalation rescues mice from fulminant hepatitis through improving hepatic energy metabolism. *Shock* 2007;27:165-71.
64. Zuckerbraun BS, Billiar TR, Otterbein SL, et al. Carbon monoxide protects against liver failure through nitric oxide-induced heme oxygenase 1. *J Exp Med* 2003;198:1707-16.
65. Hegazi RA, Rao KN, Mayle A, Sepulveda AR, Otterbein LE, Plevy SE. Carbon monoxide ameliorates chronic murine colitis through a heme oxygenase 1-dependent pathway. *J Exp Med* 2005;202:1703-13.
66. Moore BA, Overhaus M, Whitcomb J, et al. Brief inhalation of low-dose carbon monoxide protects rodents and swine from postoperative ileus. *Crit Care Med* 2005;33:1317-26.
67. Zuckerbraun BS, Otterbein LE, Boyle P, et al. Carbon monoxide protects against the development of experimental necrotizing enterocolitis. *Am J Physiol Gastrointest Liver Physiol* 2005;289:G607-13.
68. Beckman JD, Belcher JD, Vineyard JV, et al. Inhaled carbon monoxide reduces leukocytosis in a murine model of sickle cell disease. *Am J Physiol Heart Circ Physiol* 2009;297:H1243-53.
69. Takagi T, Naito Y, Inoue M, et al. Inhalation of carbon monoxide ameliorates collagen-induced arthritis in mice and regulates the articular expression of IL-1beta and MCP-1. *Inflammation* 2009;32:83-8.
70. Wang L, Lee JY, Kwak JH, He Y, Kim SI, Choi ME. Protective effects of low-dose carbon monoxide against renal fibrosis induced by unilateral ureteral obstruction. *Am J Physiol Renal Physiol* 2008;294:F508-17.
71. Coburn RF, Forster RE, Kane PB. Considerations of the physiological variables that determine the blood carboxyhemoglobin concentration in man. *J Clin Invest* 1965;44:1899-910.
72. Bernard TE, Duker J. Modeling carbon monoxide uptake during work. *Am Ind Hyg Assoc J* 1981;42:361-4.
73. Hauck H, Neuberger M. Carbon monoxide uptake and the resulting carboxyhemoglobin in man. *Eur J Appl Physiol Occup Physiol* 1984;53:186-90.
74. Joumard R, Chiron M, Vidon R, Maurin M, Rouzioux JM. Mathematical models of the uptake of carbon monoxide on hemoglobin at low carbon monoxide levels. *Environ Health Perspect* 1981;41:277-89.
75. Peterson JE, Stewart RD. Absorption and elimination of carbon monoxide by inactive young men. *Arch Environ Health* 1970;21:165-71.
76. Peterson JE, Stewart RD. Predicting the carboxyhemoglobin levels resulting from carbon monoxide exposures. *J Appl Physiol* 1975;39:633-8.
77. Tikuisis P, Buick F, Kane DM. Percent carboxyhemoglobin in resting humans exposed repeatedly to 1,500 and 7,500 ppm CO. *J Appl Physiol* (1985) 1987;63:820-7.
78. Tikuisis P, Kane DM, McLellan TM, Buick F, Fairburn SM. Rate of formation of carboxyhemoglobin in exercising humans exposed to carbon monoxide. *J Appl Physiol* 1992;72:1311-9.



## A Phase I Trial of Inhaled Carbon Monoxide for the Treatment of Sepsis-Induced ARDS

79. Hausberg M, Somers VK. Neural circulatory responses to carbon monoxide in healthy humans. *Hypertension* 1997;29:1114-8.
80. Mayr FB, Spiel A, Leitner J, et al. Effects of carbon monoxide inhalation during experimental endotoxemia in humans. *Am J Respir Crit Care Med* 2005;171:354-60.
81. Stewart RD, Peterson JE, Baretta ED, Bachand RT, Hosko MJ, Herrmann AA. Experimental human exposure to carbon monoxide. *Arch Environ Health* 1970;21:154-64.
82. Zevin S, Saunders S, Gourlay SG, Jacob P, Benowitz NL. Cardiovascular effects of carbon monoxide and cigarette smoking. *J Am Coll Cardiol* 2001;38:1633-8.
83. Rhodes MA, Carraway MS, Piantadosi CA, et al. Carbon monoxide, skeletal muscle oxidative stress, and mitochondrial biogenesis in humans. *Am J Physiol Heart Circ Physiol* 2009;297:H392-9.
84. Ren X, Dorrington KL, Robbins PA. Respiratory control in humans after 8 h of lowered arterial PO<sub>2</sub>, hemodilution, or carboxyhemoglobinemia. *J Appl Physiol* 2001;90:1189-95.
85. Bathoorn E, Slebos DJ, Postma DS, et al. Anti-inflammatory effects of inhaled carbon monoxide in patients with COPD: a pilot study. *Eur Respir J* 2007;30:1131-7.
86. Behera D, Dash S, Dinakar M. Blood carboxyhaemoglobin levels in Indian bidi and cigarette smokers. *Respiration* 1991;58:26-8.
87. Behera D, Dash S, Dinakar M. Correlation of smoking behaviour and blood carboxyhaemoglobin in bidi and cigarette smokers. *Indian J Chest Dis Allied Sci* 1991;33:43-6.
88. Stewart RD, Hake CL, Wu A, Stewart TA, Kalbfleisch JH. Carboxyhemoglobin trend in Chicago blood donors, 1970-1974. *Arch Environ Health* 1976;31:280-5.
89. Clausen JL ZL. *Pulmonary Function Testing, Guidelines and Controversies: Equipment, Methods, and Normal Values*. New York: Academic Press 1982.
90. Kraft BD, Piantadosi CA, Benjamin AM, et al. Development of a Novel Pre-Clinical Model of Pneumococcal Pneumonia in Non-Human Primates. *Am J Respir Cell Mol Biol* 2013.
91. Brealey D, Brand M, Hargreaves I, et al. Association between mitochondrial dysfunction and severity and outcome of septic shock. *Lancet* 2002;360:219-23.
92. Carre JE, Orban JC, Re L, et al. Survival in critical illness is associated with early activation of mitochondrial biogenesis. *Am J Respir Crit Care Med* 2010;182:745-51.
93. Pocock S. *Clinical Trials: A Practical Approach*. New York: John Wiley; 1984.
94. Wagner GS, Macfarlane P, Wellens H, et al. AHA/ACCF/HRS recommendations for the
95. American College of Emergency Physicians, Society for Cardiovascular Angiography Interventions, O'Gara PT, et al. 2013 ACCF/AHA guideline for the management of ST-elevation myocardial infarction: executive summary: a report of the American College of Cardiology Foundation/American Heart Association Task Force on Practice Guidelines. *J Am Coll Cardiol* 2013;61:485-510.
96. O'Connor RE, Brady W, Brooks SC, et al. Part 10: acute coronary syndromes: 2010 American Heart Association Guidelines for Cardiopulmonary Resuscitation and Emergency Cardiovascular Care. *Circulation* 2010;122:S787-817.
97. Rivara MB, Bajwa EK, Januzzi JL, Gong MN, Thompson BT, Christiani DC. Prognostic significance of elevated cardiac troponin-T levels in acute respiratory distress syndrome patients. *PLoS One* 2012;7:e40515.
98. Hopkins RO, Weaver LK, Pope D, Orme JF, Bigler ED, Larson LV. Neuropsychological sequelae and impaired health status in survivors of severe acute respiratory distress syndrome. *Am J Respir Crit Care Med* 1999;160:50-6.
99. Iwashyna TJ, Ely EW, Smith DM, Langa KM. Long-term cognitive impairment and functional disability among survivors of severe sepsis. *JAMA* 2010;304:1787-94.

## A Phase I Trial of Inhaled Carbon Monoxide for the Treatment of Sepsis-Induced ARDS

100. Jackson JC, Girard TD, Gordon SM, et al. Long-term cognitive and psychological outcomes in the awakening and breathing controlled trial. *Am J Respir Crit Care Med* 2010;182:183-91.
101. Jones C, Griffiths RD, Slater T, Benjamin KS, Wilson S. Significant cognitive dysfunction in non-delirious patients identified during and persisting following critical illness. *Intensive Care Med* 2006;32:923-6.
102. Mikkelsen ME, Christie JD, Lanken PN, et al. The adult respiratory distress syndrome cognitive outcomes study: long-term neuropsychological function in survivors of acute lung injury. *Am J Respir Crit Care Med* 2012;185:1307-15.
103. Pandharipande PP, Girard TD, Jackson JC, et al. Long-term cognitive impairment after critical illness. *N Engl J Med* 2013;369:1306-16.
104. Raub JA, Benignus VA. Carbon monoxide and the nervous system. *Neurosci Biobehav Rev* 2002;26:925-40.
105. National Bioethics Advisory Committee. *Research Involving Persons with Mental Disorders That May Affect Decision Making Capacity*. Rockville, MD: US Government Printing Office; 1998.
106. Office of Human Research Protections. *Compliance Determination Letters*; 2002.
107. Dresser R. *Research Involving Persons with Mental Disabilities: A Review of Policy Issues and Proposals*. National Bioethics Advisory Commission. Rockville: US Government Printing Office 1999:5-28.
108. American College of Physicians. Cognitively impaired subjects. *Ann Intern Med* 1989;111:843-8.