

APPENDIX E TO PART 50 [RESERVED]

APPENDIX F TO PART 50—MEASUREMENT PRINCIPLE AND CALIBRATION PROCEDURE FOR THE MEASUREMENT OF NITROGEN DIOXIDE IN THE ATMOSPHERE (GAS PHASE CHEMILUMINESCENCE)

PRINCIPLE AND APPLICABILITY

1. Atmospheric concentrations of nitrogen dioxide (NO₂) are measured indirectly by photometrically measuring the light intensity, at wavelengths greater than 600 nanometers, resulting from the chemiluminescent reaction of nitric oxide (NO) with ozone (O₃). (1,2,3) NO₂ is first quantitatively reduced to NO(4,5,6) by means of a converter. NO, which commonly exists in ambient air together with NO₂, passes through the converter unchanged causing a resultant total NO_x concentration equal to NO+NO₂. A sample of the input air is also measured without having passed through the converter. This latter NO measurement is subtracted from the former measurement (NO+NO₂) to yield the final NO₂ measurement. The NO and NO+NO₂ measurements may be made concurrently with dual systems, or cyclically with the same system provided the cycle time does not exceed 1 minute.

2. Sampling considerations.

2.1 Chemiluminescence NO/NO_x/NO₂ analyzers will respond to other nitrogen containing compounds, such as peroxyacetyl nitrate (PAN), which might be reduced to NO in the thermal converter. (7) Atmospheric concentrations of these potential interferences are generally low relative to NO₂ and valid NO₂ measurements may be obtained. In certain geographical areas, where the concentration of these potential interferences is known or suspected to be high relative to NO₂, the use of an equivalent method for the measurement of NO₂ is recommended.

2.2 The use of integrating flasks on the sample inlet line of chemiluminescence NO/NO_x/NO₂ analyzers is optional and left to the discretion of the user or the manufacturer. Use of the filter should depend on the analyzer's susceptibility to interference, malfunction, or damage due to particulates. Users are cautioned that particulate matter concentrated on a filter may cause erroneous NO₂ measurements and therefore filters should be changed frequently.

2.3 The use of particulate filters on the sample inlet line of chemiluminescence NO/NO_x/NO₂ analyzers is optional and left to the discretion of the user or the manufacturer. Use of the filter should depend on the analyzer's susceptibility to interference, malfunction, or damage due to particulates. Users are cautioned that particulate matter concentrated on a filter may cause erroneous NO₂ measurements and therefore filters should be changed frequently.

3. An analyzer based on this principle will be considered a reference method only if it has been designated as a reference method in accordance with part 53 of this chapter.

CALIBRATION

1. *Alternative A*—Gas phase titration (GPT) of an NO standard with O₃.

Major equipment required: Stable O₃ generator. Chemiluminescence NO/NO_x/NO₂ analyzer with strip chart recorder(s). NO concentration standard.

1.1 *Principle.* This calibration technique is based upon the rapid gas phase reaction between NO and O₃ to produce stoichiometric quantities of NO₂ in accordance with the following equation: (8)

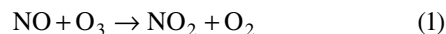

The quantitative nature of this reaction is such that when the NO concentration is known, the concentration of NO₂ can be determined. Ozone is added to excess NO in a dynamic calibration system, and the NO channel of the chemiluminescence NO/NO_x/NO₂ analyzer is used as an indicator of changes in NO concentration. Upon the addition of O₃, the decrease in NO concentration observed on the calibrated NO channel is equivalent to the concentration of NO₂ produced. The amount of NO₂ generated may be varied by adding variable amounts of O₃ from a stable uncalibrated O₃ generator. (9)

1.2 *Apparatus.* Figure 1, a schematic of a typical GPT apparatus, shows the suggested configuration of the components listed below. All connections between components in the calibration system downstream from the O₃ generator should be of glass, Teflon®, or other non-reactive material.

1.2.1 *Air flow controllers.* Devices capable of maintaining constant air flows within ±2% of the required flowrate.

1.2.2 *NO flow controller.* A device capable of maintaining constant NO flows within ±2% of the required flowrate. Component parts in contact with the NO should be of a non-reactive material.

1.2.3 *Air flowmeters.* Calibrated flowmeters capable of measuring and monitoring air flowrates with an accuracy of ±2% of the measured flowrate.

1.2.4 *NO flowmeter.* A calibrated flowmeter capable of measuring and monitoring NO flowrates with an accuracy of ±2% of the measured flowrate. (Rotameters have been reported to operate unreliably when measuring low NO flows and are not recommended.)

1.2.5 *Pressure regulator for standard NO cylinder.* This regulator must have a nonreactive diaphragm and internal parts and a suitable delivery pressure.

1.2.6 *Ozone generator.* The generator must be capable of generating sufficient and stable levels of O₃ for reaction with NO to generate

NO₂ concentrations in the range required. Ozone generators of the electric discharge type may produce NO and NO₂ and are not recommended.

1.2.7 *Valve*. A valve may be used as shown in Figure 1 to divert the NO flow when zero air is required at the manifold. The valve should be constructed of glass, Teflon®, or other nonreactive material.

1.2.8 *Reaction chamber*. A chamber, constructed of glass, Teflon®, or other nonreactive material, for the quantitative reaction of O₃ with excess NO. The chamber should be of sufficient volume (V_{RC}) such that the residence time (t_R) meets the requirements specified in 1.4. For practical reasons, t_R should be less than 2 minutes.

1.2.9 *Mixing chamber*. A chamber constructed of glass, Teflon®, or other nonreactive material and designed to provide thorough mixing of reaction products and diluent air. The residence time is not critical when the dynamic parameter specification given in 1.4 is met.

1.2.10 *Output manifold*. The output manifold should be constructed of glass, Teflon®, or other non-reactive material and should be of sufficient diameter to insure an insignificant pressure drop at the analyzer connection. The system must have a vent designed to insure atmospheric pressure at the manifold and to prevent ambient air from entering the manifold.

1.3 Reagents.

1.3.1 *NO concentration standard*. Gas cylinder standard containing 50 to 100 ppm NO in N₂ with less than 1 ppm NO₂. This standard must be traceable to a National Bureau of Standards (NBS) NO in N₂ Standard Reference Material (SRM 1683 or SRM 1684), an NBS NO₂ Standard Reference Material (SRM 1629), or an NBS/EPA-approved commercially available Certified Reference Material (CRM). CRM's are described in Reference 14, and a list of CRM sources is available from the address shown for Reference 14. A recommended protocol for certifying NO gas cylinders against either an NO SRM or CRM is given in section 2.0.7 of Reference 15. Reference 13 gives procedures for certifying an NO gas cylinder against an NBS NO₂ SRM and for determining the amount of NO₂ impurity in an NO cylinder.

1.3.2 *Zero air*. Air, free of contaminants which will cause a detectable response on the NO/NO_x/NO₂ analyzer or which might react with either NO, O₃, or NO₂ in the gas phase titration. A procedure for generating zero air is given in reference 13.

1.4 Dynamic parameter specification.

1.4.1 The O₃ generator air flowrate (F_O) and NO flowrate (F_{NO}) (see Figure 1) must be adjusted such that the following relationship holds:

$$P_R = [\text{NO}]_{RC} \times t_R \text{ 2.75 ppm-minutes} \quad (2)$$

$$[\text{NO}]_{RC} = [\text{NO}]_{\text{STD}} \left(\frac{F_{\text{NO}}}{F_O + F_{\text{NO}}} \right) \quad (3)$$

$$t_R = \frac{V_{RC}}{F_O + F_{\text{NO}}} < 2 \text{ minutes} \quad (4)$$

where:

P_R = dynamic parameter specification, determined empirically, to insure complete reaction of the available O₃, ppm-minute

$[\text{NO}]_{RC}$ = NO concentration in the reaction chamber, ppm

t_R = residence time of the reactant gases in the reaction chamber, minute

$[\text{NO}]_{\text{STD}}$ = concentration of the undiluted NO standard, ppm

F_{NO} = NO flowrate, scm³/min

F_O = O₃ generator air flowrate, scm³/min

V_{RC} = volume of the reaction chamber, scm³

1.4.2 The flow conditions to be used in the GPT system are determined by the following procedure:

(a) Determine F_T , the total flow required at the output manifold (F_T =analyzer demand plus 10 to 50% excess).

(b) Establish $[\text{NO}]_{\text{OUT}}$ as the highest NO concentration (ppm) which will be required at the output manifold. $[\text{NO}]_{\text{OUT}}$ should be approximately equivalent to 90% of the upper range limit (URL) of the NO₂ concentration range to be covered.

(c) Determine F_{NO} as

$$F_{\text{NO}} = \frac{[\text{NO}]_{\text{OUT}} \times F_T}{[\text{NO}]_{\text{STD}}} \quad (5)$$

(d) Select a convenient or available reaction chamber volume. Initially, a trial V_{RC} may be selected to be in the range of approximately 200 to 500 scm³.

(e) Compute F_O as

$$F_O = \sqrt{\frac{[\text{NO}]_{\text{STD}} \times F_{\text{NO}} \times V_{RC}}{2.75}} - F_{\text{NO}} \quad (6)$$

(f) Compute t_R as

$$t_R = \frac{V_{RC}}{F_O + F_{\text{NO}}} \quad (7)$$

Verify that $t_R < 2$ minutes. If not, select a reaction chamber with a smaller V_{RC} .

(g) Compute the diluent air flowrate as

$$F_D = F_T - F_O - F_{\text{NO}} \quad (8)$$

where:

F_D = diluent air flowrate, scm³/min

(h) If F_O turns out to be impractical for the desired system, select a reaction chamber

having a different V_{RC} and recompute F_O and F_D .

NOTE: A dynamic parameter lower than 2.75 ppm-minutes may be used if it can be determined empirically that quantitative reaction of O_3 with NO occurs. A procedure for making this determination as well as a more detailed discussion of the above requirements and other related considerations is given in reference 13.

1.5 Procedure.

1.5.1 Assemble a dynamic calibration system such as the one shown in Figure 1.

1.5.2 Insure that all flowmeters are calibrated under the conditions of use against a reliable standard such as a soap-bubble meter or wet-test meter. All volumetric flowrates should be corrected to 25 °C and 760 mm Hg. A discussion on the calibration of flowmeters is given in reference 13.

1.5.3 Precautions must be taken to remove O_2 and other contaminants from the NO pressure regulator and delivery system prior to the start of calibration to avoid any conversion of the standard NO to NO_2 . Failure to do so can cause significant errors in calibration. This problem may be minimized by (1) carefully evacuating the regulator, when possible, after the regulator has been connected to the cylinder and before opening the cylinder valve; (2) thoroughly flushing the regulator and delivery system with NO after opening the cylinder valve; (3) not removing the regulator from the cylinder between calibrations unless absolutely necessary. Further discussion of these procedures is given in reference 13.

1.5.4 Select the operating range of the NO/ NO_x / NO_2 analyzer to be calibrated. In order to obtain maximum precision and accuracy for NO_2 calibration, all three channels of the analyzer should be set to the same range. If operation of the NO and NO_x channels on higher ranges is desired, subsequent recalibration of the NO and NO_x channels on the higher ranges is recommended.

NOTE: Some analyzer designs may require identical ranges for NO, NO_x , and NO_2 during operation of the analyzer.

1.5.5 Connect the recorder output cable(s) of the NO/ NO_x / NO_2 analyzer to the input terminals of the strip chart recorder(s). All adjustments to the analyzer should be performed based on the appropriate strip chart readings. References to analyzer responses in the procedures given below refer to recorder responses.

1.5.6 Determine the GPT flow conditions required to meet the dynamic parameter specification as indicated in 1.4.

1.5.7 Adjust the diluent air and O_3 generator air flows to obtain the flows determined in section 1.4.2. The total air flow must exceed the total demand of the analyzer(s) connected to the output manifold to insure that no ambient air is pulled into the manifold

vent. Allow the analyzer to sample zero air until stable NO, NO_x , and NO_2 responses are obtained. After the responses have stabilized, adjust the analyzer zero control(s).

NOTE: Some analyzers may have separate zero controls for NO, NO_x , and NO_2 . Other analyzers may have separate zero controls only for NO and NO_x , while still others may have only one zero control common to all three channels.

Offsetting the analyzer zero adjustments to +5 percent of scale is recommended to facilitate observing negative zero drift. Record the stable zero air responses as Z_{NO} , Z_{NOX} , and Z_{NO2} .

1.5.8 Preparation of NO and NO_x calibration curves.

1.5.8.1 *Adjustment of NO span control.* Adjust the NO flow from the standard NO cylinder to generate an NO concentration of approximately 80 percent of the upper range limit (URL) of the NO range. This exact NO concentration is calculated from:

$$[NO]_{OUT} = \frac{F_{NO} \times [NO]_{STD}}{F_{NO} + F_O + F_D} \quad (9)$$

where:

$[NO]_{OUT}$ = diluted NO concentration at the output manifold, ppm

Sample this NO concentration until the NO and NO_x responses have stabilized. Adjust the NO span control to obtain a recorder response as indicated below:

recorder response (percent scale) =

$$\left(\frac{[NO]_{OUT} \times 100}{URL} \right) + Z_{NO} \quad (10)$$

where:

URL = nominal upper range limit of the NO channel, ppm

NOTE: Some analyzers may have separate span controls for NO, NO_x , and NO_2 . Other analyzers may have separate span controls only for NO and NO_x , while still others may have only one span control common to all three channels. When only one span control is available, the span adjustment is made on the NO channel of the analyzer.

If substantial adjustment of the NO span control is necessary, it may be necessary to recheck the zero and span adjustments by repeating steps 1.5.7 and 1.5.8.1. Record the NO concentration and the analyzer's NO response.

1.5.8.2 *Adjustment of NO_x span control.* When adjusting the analyzer's NO_x span control, the presence of any NO_2 impurity in the standard NO cylinder must be taken into account. Procedures for determining the amount of NO_2 impurity in the standard NO

cylinder are given in reference 13. The exact NO_x concentration is calculated from:

$$[\text{NO}_x]_{\text{OUT}} = \frac{F_{\text{NO}} \times ([\text{NO}]_{\text{STD}} + [\text{NO}_2]_{\text{IMP}})}{F_{\text{NO}} + F_{\text{O}} + F_{\text{D}}} \quad (11)$$

where:

[NO_x]_{OUT} = diluted NO_x concentration at the output manifold, ppm

[NO₂]_{IMP} = concentration of NO₂ impurity in the standard NO cylinder, ppm

Adjust the NO_x span control to obtain a recorder response as indicated below:

recorder response (% scale) =

$$\left(\frac{[\text{NO}_x]_{\text{OUT}} \times 100}{\text{URL}} \right) + Z_{\text{NO}_x} \quad (12)$$

NOTE: If the analyzer has only one span control, the span adjustment is made on the NO channel and no further adjustment is made here for NO_x.

If substantial adjustment of the NO_x span control is necessary, it may be necessary to recheck the zero and span adjustments by repeating steps 1.5.7 and 1.5.8.2. Record the NO_x concentration and the analyzer's NO_x response.

1.5.8.3 Generate several additional concentrations (at least five evenly spaced points across the remaining scale are suggested to verify linearity) by decreasing F_{NO} or increasing F_D. For each concentration generated, calculate the exact NO and NO_x

concentrations using equations (9) and (11) respectively. Record the analyzer's NO and NO_x responses for each concentration. Plot the analyzer responses versus the respective calculated NO and NO_x concentrations and draw or calculate the NO and NO_x calibration curves. For subsequent calibrations where linearity can be assumed, these curves may be checked with a two-point calibration consisting of a zero air point and NO and NO_x concentrations of approximately 80% of the URL.

1.5.9 Preparation of NO₂ calibration curve.

1.5.9.1 Assuming the NO₂ zero has been properly adjusted while sampling zero air in step 1.5.7, adjust F_O and F_D as determined in section 1.4.2. Adjust F_{NO} to generate an NO concentration near 90% of the URL of the NO range. Sample this NO concentration until the NO and NO_x responses have stabilized. Using the NO calibration curve obtained in section 1.5.8, measure and record the NO concentration as [NO]_{orig}. Using the NO_x calibration curve obtained in section 1.5.8, measure and record the NO_x concentration as [NO_x]_{orig}.

1.5.9.2 Adjust the O₃ generator to generate sufficient O₃ to produce a decrease in the NO concentration equivalent to approximately 80% of the URL of the NO₂ range. The decrease must not exceed 90% of the NO concentration determined in step 1.5.9.1. After the analyzer responses have stabilized, record the resultant NO and NO_x concentrations as [NO]_{rem} and [NO_x]_{rem}.

1.5.9.3 Calculate the resulting NO₂ concentration from:

$$[\text{NO}_2]_{\text{OUT}} = [\text{NO}]_{\text{orig}} - [\text{NO}]_{\text{rem}} + \frac{F_{\text{NO}} \times [\text{NO}_2]_{\text{IMP}}}{F_{\text{NO}} + F_{\text{O}} + F_{\text{D}}} \quad (13)$$

where:

[NO₂]_{OUT} = diluted NO₂ concentration at the output manifold, ppm

[NO]_{orig} = original NO concentration, prior to addition of O₃, ppm

[NO]_{rem} = NO concentration remaining after addition of O₃, ppm

Adjust the NO₂ span control to obtain a recorder response as indicated below:

recorder response (% scale) =

$$\left(\frac{[\text{NO}_2]_{\text{OUT}} \times 100}{\text{URL}} \right) + Z_{\text{NO}_2} \quad (14)$$

NOTE: If the analyzer has only one or two span controls, the span adjustments are made on the NO channel or NO and NO_x channels and no further adjustment is made here for NO₂.

If substantial adjustment of the NO₂ span control is necessary, it may be necessary to recheck the zero and span adjustments by repeating steps 1.5.7 and 1.5.9.3. Record the NO₂ concentration and the corresponding analyzer NO₂ and NO_x responses.

1.5.9.4 Maintaining the same F_{NO}, F_O, and F_D as in section 1.5.9.1, adjust the ozone generator to obtain several other concentrations of NO₂ over the NO₂ range (at least five evenly spaced points across the remaining scale are suggested). Calculate each NO₂ concentration using equation (13) and record the corresponding analyzer NO₂ and NO_x responses. Plot the analyzer's NO₂ responses versus the corresponding calculated NO₂ concentrations and draw or calculate the NO₂ calibration curve.

1.5.10 Determination of converter efficiency.

1.5.10.1 For each NO₂ concentration generated during the preparation of the NO₂

calibration curve (see section 1.5.9) calculate the concentration of NO₂ converted from:

$$[\text{NO}_2]_{\text{CONV}} = [\text{NO}_2]_{\text{OUT}} \left(\frac{[\text{NO}_X]_{\text{orig}}}{[\text{NO}_X]_{\text{rem}}} \right) \quad (15)$$

where:

[NO₂]_{CONV} = concentration of NO₂ converted, ppm

[NO_X]_{orig} = original NO_X concentration prior to addition of O₃, ppm

[NO_X]_{rem} = NO_X concentration remaining after addition of O₃, ppm

NOTE: Supplemental information on calibration and other procedures in this method are given in reference 13.

Plot [NO₂]_{CONV} (y-axis) versus [NO₂]_{OUT} (x-axis) and draw or calculate the converter efficiency curve. The slope of the curve times 100 is the average converter efficiency, E_C. The average converter efficiency must be greater than 96%; if it is less than 96%, replace or service the converter.

2. Alternative B—NO₂ permeation device.

Major equipment required:

Stable O₃ generator.

Chemiluminescence NO/NO_X/NO₂ analyzer with strip chart recorder(s).

NO concentration standard.

NO₂ concentration standard.

2.1 *Principle.* Atmospheres containing accurately known concentrations of nitrogen dioxide are generated by means of a permeation device. (10) The permeation device emits NO₂ at a known constant rate provided the temperature of the device is held constant (±0.1 °C) and the device has been accurately calibrated at the temperature of use. The NO₂ emitted from the device is diluted with zero air to produce NO₂ concentrations suitable for calibration of the NO₂ channel of the NO/NO_X/NO₂ analyzer. An NO concentration standard is used for calibration of the NO and NO_X channels of the analyzer.

2.2 *Apparatus.* A typical system suitable for generating the required NO and NO₂ concentrations is shown in Figure 2. All connections between components downstream from the permeation device should be of glass, Teflon®, or other non-reactive material.

2.2.1 *Air flow controllers.* Devices capable of maintaining constant air flows within ±2% of the required flowrate.

2.2.2 *NO flow controller.* A device capable of maintaining constant NO flows within ±2% of the required flowrate. Component parts in contact with the NO must be of a non-reactive material.

2.2.3 *Air flowmeters.* Calibrated flowmeters capable of measuring and monitoring air flowrates with an accuracy of ±2% of the measured flowrate.

2.2.4 *NO flowmeter.* A calibrated flowmeter capable of measuring and monitoring NO flowrates with an accuracy of ±2% of the measured flowrate. (Rotameters have been reported to operate unreliably when measuring low NO flows and are not recommended.)

2.2.5 *Pressure regulator for standard NO cylinder.* This regulator must have a non-reactive diaphragm and internal parts and a suitable delivery pressure.

2.2.6 *Drier.* Scrubber to remove moisture from the permeation device air system. The use of the drier is optional with NO₂ permeation devices not sensitive to moisture. (Refer to the supplier's instructions for use of the permeation device.)

2.2.7 *Constant temperature chamber.* Chamber capable of housing the NO₂ permeation device and maintaining its temperature to within ±0.1 °C.

2.2.8 *Temperature measuring device.* Device capable of measuring and monitoring the temperature of the NO₂ permeation device with an accuracy of ±0.05 °C.

2.2.9 *Valves.* A valve may be used as shown in Figure 2 to divert the NO₂ from the permeation device when zero air or NO is required at the manifold. A second valve may be used to divert the NO flow when zero air or NO₂ is required at the manifold.

The valves should be constructed of glass, Teflon®, or other nonreactive material.

2.2.10 *Mixing chamber.* A chamber constructed of glass, Teflon®, or other nonreactive material and designed to provide thorough mixing of pollutant gas streams and diluent air.

2.2.11 *Output manifold.* The output manifold should be constructed of glass, Teflon®, or other non-reactive material and should be of sufficient diameter to insure an insignificant pressure drop at the analyzer connection. The system must have a vent designed to insure atmospheric pressure at the manifold and to prevent ambient air from entering the manifold.

2.3 Reagents.

2.3.1 *Calibration standards.* Calibration standards are required for both NO and NO₂. The reference standard for the calibration may be either an NO or NO₂ standard, and must be traceable to a National Bureau of Standards (NBS) NO in N₂ Standard Reference Material (SRM 1683 or SRM 1684), and NBS NO₂ Standard Reference Material (SRM 1629), or an NBS/EPA-approved commercially

available Certified Reference Material (CRM). CRM's are described in Reference 14, and a list of CRM sources is available from the address shown for Reference 14. Reference 15 gives recommended procedures for certifying an NO gas cylinder against an NO SRM or CRM and for certifying an NO₂ permeation device against an NO₂ SRM. Reference 13 contains procedures for certifying an NO gas cylinder against an NO₂ SRM and for certifying an NO₂ permeation device against an NO SRM or CRM. A procedure for determining the amount of NO₂ impurity in an NO cylinder is also contained in Reference 13. The NO or NO₂ standard selected as the reference standard must be used to certify the other standard to ensure consistency between the two standards.

2.3.1.1 *NO₂ Concentration standard.* A permeation device suitable for generating NO₂ concentrations at the required flow-rates over the required concentration range. If the permeation device is used as the reference standard, it must be traceable to an SRM or CRM as specified in 2.3.1. If an NO cylinder is used as the reference standard, the NO₂ permeation device must be certified against the NO standard according to the procedure given in Reference 13. The use of the permeation device should be in strict accordance with the instructions supplied with the device. Additional information regarding the use of permeation devices is given by Scaringelli et al. (11) and Rook et al. (12).

2.3.1.2 *NO Concentration standard.* Gas cylinder containing 50 to 100 ppm NO in N₂ with less than 1 ppm NO₂. If this cylinder is used as the reference standard, the cylinder must be traceable to an SRM or CRM as specified in 2.3.1. If an NO₂ permeation device is used as the reference standard, the NO cylinder must be certified against the NO₂ standard according to the procedure given in Reference 13. The cylinder should be recertified on a regular basis as determined by the local quality control program.

2.3.3 *Zero air.* Air, free of contaminants which might react with NO or NO₂ or cause a detectable response on the NO/NO_x/NO₂ analyzer. When using permeation devices that are sensitive to moisture, the zero air passing across the permeation device must be dry to avoid surface reactions on the device. (Refer to the supplier's instructions for use of the permeation device.) A procedure for generating zero air is given in reference 13.

2.4 Procedure.

2.4.1 Assemble the calibration apparatus such as the typical one shown in Figure 2.

2.4.2 Insure that all flowmeters are calibrated under the conditions of use against a reliable standard such as a soap bubble meter or wet-test meter. All volumetric flowrates should be corrected to 25 °C and 760 mm Hg. A discussion on the calibration of flowmeters is given in reference 13.

2.4.3 Install the permeation device in the constant temperature chamber. Provide a small fixed air flow (200-400 scm³/min) across the device. The permeation device should always have a continuous air flow across it to prevent large buildup of NO₂ in the system and a consequent restabilization period. Record the flowrate as FP. Allow the device to stabilize at the calibration temperature for at least 24 hours. The temperature must be adjusted and controlled to within ±0.1 °C or less of the calibration temperature as monitored with the temperature measuring device.

2.4.4 Precautions must be taken to remove O₂ and other contaminants from the NO pressure regulator and delivery system prior to the start of calibration to avoid any conversion of the standard NO to NO₂. Failure to do so can cause significant errors in calibration. This problem may be minimized by

(1) Carefully evacuating the regulator, when possible, after the regulator has been connected to the cylinder and before opening the cylinder valve;

(2) Thoroughly flushing the regulator and delivery system with NO after opening the cylinder valve;

(3) Not removing the regulator from the cylinder between calibrations unless absolutely necessary. Further discussion of these procedures is given in reference 13.

2.4.5 Select the operating range of the NO/NO_x NO₂ analyzer to be calibrated. In order to obtain maximum precision and accuracy for NO₂ calibration, all three channels of the analyzer should be set to the same range. If operation of the NO and NO_x channels on higher ranges is desired, subsequent recalibration of the NO and NO_x channels on the higher ranges is recommended.

NOTE: Some analyzer designs may require identical ranges for NO, NO_x, and NO₂ during operation of the analyzer.

2.4.6 Connect the recorder output cable(s) of the NO/NO_x/NO₂ analyzer to the input terminals of the strip chart recorder(s). All adjustments to the analyzer should be performed based on the appropriate strip chart readings. References to analyzer responses in the procedures given below refer to recorder responses.

2.4.7 Switch the valve to vent the flow from the permeation device and adjust the diluent air flowrate, F_D, to provide zero air at the output manifold. The total air flow must exceed the total demand of the analyzer(s) connected to the output manifold to insure that no ambient air is pulled into the manifold vent. Allow the analyzer to sample zero air until stable NO, NO_x, and NO₂ responses are obtained. After the responses have stabilized, adjust the analyzer zero control(s).

NOTE: Some analyzers may have separate zero controls for NO, NO_x, and NO₂. Other analyzers may have separate zero controls

only for NO and NO_x, while still others may have only one zero common control to all three channels.

Offsetting the analyzer zero adjustments to +5% of scale is recommended to facilitate observing negative zero drift. Record the stable zero air responses as Z_{NO}, Z_{NO_x}, and Z_{NO₂}.

2.4.8 Preparation of NO and NO_x calibration curves.

2.4.8.1 Adjustment of NO span control. Adjust the NO flow from the standard NO cylinder to generate an NO concentration of approximately 80% of the upper range limit (URL) of the NO range. The exact NO concentration is calculated from:

$$[\text{NO}]_{\text{OUT}} = \frac{F_{\text{NO}} \times [\text{NO}]_{\text{STD}}}{F_{\text{NO}} + F_{\text{D}}} \quad (16)$$

where:

[NO]_{OUT} = diluted NO concentration at the output manifold, ppm

F_{NO} = NO flowrate, scm³/min

[NO]_{STD} = concentration of the undiluted NO standard, ppm

F_D = diluent air flowrate, scm³/min

Sample this NO concentration until the NO and NO_x responses have stabilized. Adjust the NO span control to obtain a recorder response as indicated below:

recorder response (% scale) =

$$= \left(\frac{[\text{NO}]_{\text{OUT}}}{\text{URL}} \times 100 \right) + Z_{\text{NO}} \quad (17)$$

$$= \left(\frac{[\text{NO}_x]_{\text{OUT}}}{\text{URL}} \times 100 \right) + Z_{\text{NO}_x} \quad (19)$$

where:

URL = nominal upper range limit of the NO channel, ppm

NOTE: Some analyzers may have separate span controls for NO, NO_x, and NO₂. Other analyzers may have separate span controls only for NO and NO_x, while still others may have only one span control common to all three channels. When only one span control is available, the span adjustment is made on the NO channel of the analyzer.

If substantial adjustment of the NO span control is necessary, it may be necessary to recheck the zero and span adjustments by repeating steps 2.4.7 and 2.4.8.1. Record the NO concentration and the analyzer's NO response.

2.4.8.2 Adjustment of NO_x span control. When adjusting the analyzer's NO_x span control, the presence of any NO₂ impurity in the standard NO cylinder must be taken into account. Procedures for determining the amount of NO₂ impurity in the standard NO

cylinder are given in reference 13. The exact NO_x concentration is calculated from:

$$[\text{NO}_x]_{\text{OUT}} = \frac{F_{\text{NO}} \times ([\text{NO}]_{\text{STD}} + [\text{NO}_2]_{\text{IMP}})}{F_{\text{NO}} + F_{\text{D}}} \quad (18)$$

where:

[NO_x]_{OUT} = diluted NO_x concentration at the output manifold, ppm

[NO₂]_{IMP} = concentration of NO₂ impurity in the standard NO cylinder, ppm

Adjust the NO_x span control to obtain a convenient recorder response as indicated below: recorder response (% scale)

$$= \left(\frac{[\text{NO}_x]_{\text{OUT}}}{\text{URL}} \times 100 \right) + Z_{\text{NO}_x} \quad (19)$$

NOTE: If the analyzer has only one span control, the span adjustment is made on the NO channel and no further adjustment is made here for NO_x.

If substantial adjustment of the NO_x span control is necessary, it may be necessary to recheck the zero and span adjustments by repeating steps 2.4.7 and 2.4.8.2. Record the NO_x concentration and the analyzer's NO_x response.

2.4.8.3 Generate several additional concentrations (at least five evenly spaced points across the remaining scale are suggested to verify linearity) by decreasing F_{NO} or increasing F_D. For each concentration generated, calculate the exact NO and NO_x concentrations using equations (16) and (18) respectively. Record the analyzer's NO and NO_x responses for each concentration. Plot the analyzer responses versus the respective calculated NO and NO_x concentrations and draw or calculate the NO and NO_x calibration curves. For subsequent calibrations where linearity can be assumed, these curves may be checked with a two-point calibration consisting of a zero point and NO and NO_x concentrations of approximately 80 percent of the URL.

2.4.9 Preparation of NO₂ calibration curve.

2.4.9.1 Remove the NO flow. Assuming the NO₂ zero has been properly adjusted while sampling zero air in step 2.4.7, switch the valve to provide NO₂ at the output manifold.

2.4.9.2 Adjust F_D to generate an NO₂ concentration of approximately 80 percent of the URL of the NO₂ range. The total air flow must exceed the demand of the analyzer(s) under calibration. The actual concentration of NO₂ is calculated from:

$$[\text{NO}_2]_{\text{OUT}} = \frac{R \times K}{F_{\text{P}} + F_{\text{D}}} \quad (20)$$

where:

$[\text{NO}_2]_{\text{OUT}}$ = diluted NO_2 concentration at the output manifold, ppm

R = permeation rate, $\mu\text{g}/\text{min}$

$K = 0.532 \mu\text{l NO}_2/\mu\text{g NO}_2$ (at 25 °C and 760 mm Hg)

F_p = air flowrate across permeation device, scm^3/min

F_D = diluent air flowrate, scm^3/min

Sample this NO_2 concentration until the NO_x and NO_2 responses have stabilized. Adjust the NO_2 span control to obtain a recorder response as indicated below:

recorder response (% scale)

$$= \left(\frac{[\text{NO}_2]_{\text{OUT}}}{URL} \times 100 \right) + Z_{\text{NO}_2} \quad (21)$$

NOTE: If the analyzer has only one or two span controls, the span adjustments are made on the NO channel or NO and NO_x channels and no further adjustment is made here for NO_2 .

If substantial adjustment of the NO_2 span control is necessary it may be necessary to recheck the zero and span adjustments by repeating steps 2.4.7 and 2.4.9.2. Record the NO_2 concentration and the analyzer's NO_2 response. Using the NO_x calibration curve obtained in step 2.4.8, measure and record the NO_x concentration as $[\text{NO}_x]_{\text{M}}$.

2.4.9.3 Adjust F_D to obtain several other concentrations of NO_2 over the NO_2 range (at least five evenly spaced points across the remaining scale are suggested). Calculate each NO_2 concentration using equation (20) and record the corresponding analyzer NO_2 and NO_x responses. Plot the analyzer's NO_2 responses versus the corresponding calculated NO_2 concentrations and draw or calculate the NO_2 calibration curve.

2.4.10 *Determination of converter efficiency.*

2.4.10.1 Plot $[\text{NO}_x]_{\text{M}}$ (y-axis) versus $[\text{NO}_2]_{\text{OUT}}$ (x-axis) and draw or calculate the converter efficiency curve. The slope of the curve times 100 is the average converter efficiency, E_c . The average converter efficiency must be greater than 96 percent; if it is less than 96 percent, replace or service the converter.

NOTE: Supplemental information on calibration and other procedures in this method are given in reference 13.

3. *Frequency of calibration.* The frequency of calibration, as well as the number of points necessary to establish the calibration curve and the frequency of other performance checks, will vary from one analyzer to another. The user's quality control program should provide guidelines for initial establishment of these variables and for subsequent alteration as operational experience is accumulated. Manufacturers of analyzers should include in their instruction/operation manuals information and guidance as to these variables and on other matters of operation, calibration, and quality control.

REFERENCES

1. A. Fontijn, A. J. Sabadell, and R. J. Ronco, "Homogeneous Chemiluminescent Measurement of Nitric Oxide with Ozone," *Anal. Chem.*, 42, 575 (1970).
2. D. H. Stedman, E. E. Daby, F. Stuhl, and H. Niki, "Analysis of Ozone and Nitric Oxide by a Chemiluminescent Method in Laboratory and Atmospheric Studies of Photochemical Smog," *J. Air Poll. Control Assoc.*, 22, 260 (1972).
3. B. E. Martin, J. A. Hodgeson, and R. K. Stevens, "Detection of Nitric Oxide Chemiluminescence at Atmospheric Pressure," Presented at 164th National ACS Meeting, New York City, August 1972.
4. J. A. Hodgeson, K. A. Rehme, B. E. Martin, and R. K. Stevens, "Measurements for Atmospheric Oxides of Nitrogen and Ammonia by Chemiluminescence," Presented at 1972 APCA Meeting, Miami, FL, June 1972.
5. R. K. Stevens and J. A. Hodgeson, "Applications of Chemiluminescence Reactions to the Measurement of Air Pollutants," *Anal. Chem.*, 45, 443A (1973).
6. L. P. Breitenbach and M. Shelef, "Development of a Method for the Analysis of NO_2 and NH_3 by NO-Measuring Instruments," *J. Air Poll. Control Assoc.*, 23, 128 (1973).
7. A. M. Winer, J. W. Peters, J. P. Smith, and J. N. Pitts, Jr., "Response of Commercial Chemiluminescent NO- NO_2 Analyzers to Other Nitrogen-Containing Compounds," *Environ. Sci. Technol.*, 8, 1118 (1974).
8. K. A. Rehme, B. E. Martin, and J. A. Hodgeson, Tentative Method for the Calibration of Nitric Oxide, Nitrogen Dioxide, and Ozone Analyzers by Gas Phase Titration," EPA-R2-73-246, March 1974.
9. J. A. Hodgeson, R. K. Stevens, and B. E. Martin, "A Stable Ozone Source Applicable as a Secondary Standard for Calibration of Atmospheric Monitors," *ISA Transactions*, 11, 161 (1972).
10. A. E. O'Keefe and G. C. Ortman, "Primary Standards for Trace Gas Analysis," *Anal. Chem.*, 38, 760 (1966).
11. F. P. Scaringelli, A. E. O'Keefe, E. Rosenberg, and J. P. Bell, "Preparation of Known Concentrations of Gases and Vapors with Permeation Devices Calibrated Gravimetrically," *Anal. Chem.*, 42, 871 (1970).
12. H. L. Rook, E. E. Hughes, R. S. Fuerst, and J. H. Margeson, "Operation Characteristics of NO_2 Permeation Devices," Presented at 167th National ACS Meeting, Los Angeles, CA, April 1974.
13. E. C. Ellis, "Technical Assistance Document for the Chemiluminescence Measurement of Nitrogen Dioxide," EPA-E600/4-75-003 (Available in draft form from the United States Environmental Protection Agency, Department E (MD-76), Environmental Monitoring and Support Laboratory, Research Triangle Park, NC 27711).

14. A Procedure for Establishing Traceability of Gas Mixtures to Certain National Bureau of Standards Standard Reference Materials. EPA-600/7-81-010, Joint publication by NBS and EPA. Available from the U.S. Environmental Protection Agency, Environmental Monitoring Systems Laboratory (MD-77), Research Triangle Park, NC 27711, May 1981.

15. *Quality Assurance Handbook for Air Pollution Measurement Systems, Volume II, Ambient Air Specific Methods*. The U.S. Environmental Protection Agency, Environmental Monitoring Systems Laboratory, Research Triangle Park, NC 27711. Publication No. EAP-600/4-77-027a.

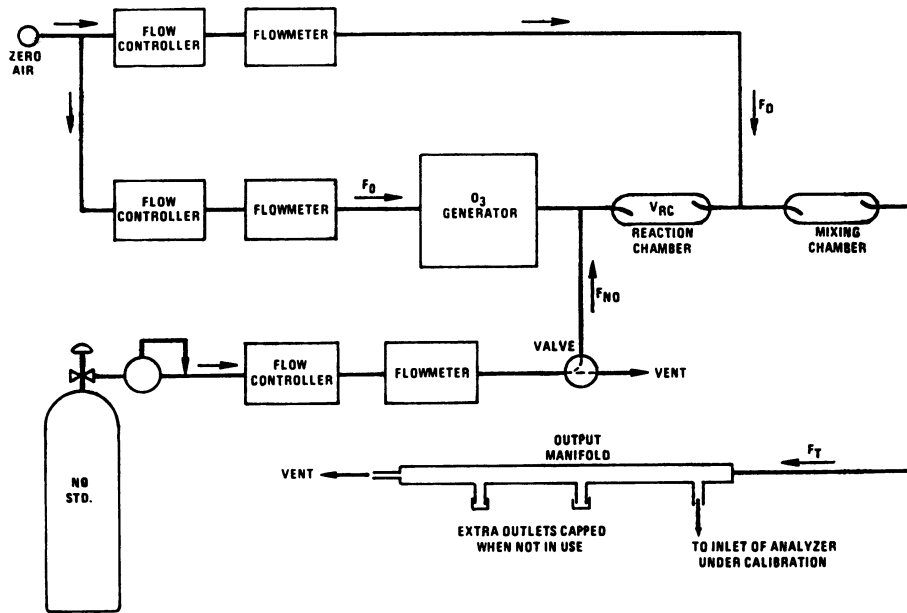

Figure 1. Schematic diagram of a typical GPT calibration system.

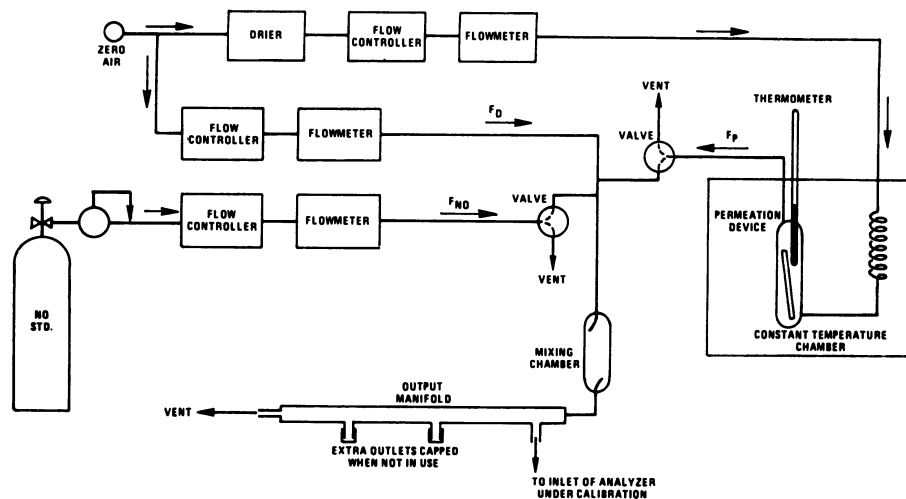

Figure 2. Schematic diagram of a typical calibration apparatus using an NO₂ permeation device.

[41 FR 52688, Dec. 1, 1976, as amended at 48 FR 2529, Jan 20, 1983]

APPENDIX G TO PART 50—REFERENCE METHOD FOR THE DETERMINATION OF LEAD IN SUSPENDED PARTICULATE MATTER COLLECTED FROM AMBIENT AIR

1. Principle and applicability.

1.1 Ambient air suspended particulate matter is collected on a glass-fiber filter for 24 hours using a high volume air sampler. The analysis of the 24-hour samples may be performed for either individual samples or composites of the samples collected over a calendar month or quarter, provided that the compositing procedure has been approved in accordance with section 2.8 of appendix C to part 58 of this chapter—*Modifications of methods by users*. (Guidance or assistance in requesting approval under Section 2.8 can be obtained from the address given in section 2.7 of appendix C to part 58 of this chapter.)

1.2 Lead in the particulate matter is solubilized by extraction with nitric acid (HNO₃), facilitated by heat or by a mixture of HNO₃ and hydrochloric acid (HCl) facilitated by ultrasonication.

1.3 The lead content of the sample is analyzed by atomic absorption spectrometry using an air-acetylene flame, the 283.3 or 217.0 nm lead absorption line, and the optimum instrumental conditions recommended by the manufacturer.

1.4 The ultrasonication extraction with HNO₃/HCl will extract metals other than lead from ambient particulate matter.

2. Range, sensitivity, and lower detectable limit. The values given below are typical of the methods capabilities. Absolute values will vary for individual situations depending on the type of instrument used, the lead line, and operating conditions.

2.1 Range. The typical range of the method is 0.07 to 7.5 µg Pb/m³ assuming an upper linear range of analysis of 15 µg/ml and an air volume of 2,400 m³.

2.2 Sensitivity. Typical sensitivities for a 1 percent change in absorption (0.0044 absorbance units) are 0.2 and 0.5 µg Pb/ml for the 217.0 and 283.3 nm lines, respectively.

2.3 Lower detectable limit (LDL). A typical LDL is 0.07 µg Pb/m³. The above value was calculated by doubling the between-laboratory standard deviation obtained for the lowest measurable lead concentration in a collaborative test of the method.⁽¹⁵⁾ An air volume of 2,400 m³ was assumed.

3. Interferences. Two types of interferences are possible: chemical and light scattering.

3.1 Chemical. Reports on the absence (1, 2, 3, 4, 5) of chemical interferences far outweigh those reporting their presence, (6) therefore, no correction for chemical interferences is given here. If the analyst suspects that the sample matrix is causing a chemical interference, the interference can be verified and corrected for by carrying out the analysis