

Supplemental Figure 1

52 statistically significant KEGG pathways enriched with 1088 overlapped molecules (DEGs; proteins)

1. Focal adhesion
2. Carbon metabolism
3. Platelet activation
4. Dopaminergic synapse
5. Human cytomegalovirus infection
6. Proteoglycans in cancer
7. Regulation of actin cytoskeleton
8. cGMP-PKG signaling pathway
9. Retrograde endocannabinoid signaling
10. Biosynthesis of amino acids
11. Thyroid hormone signaling pathway
12. Adrenergic signaling in cardiomyocytes
13. ECM-receptor interaction
14. Relaxin signaling pathway
15. Insulin signaling pathway
16. PPAR signaling pathway
17. Neurotrophin signaling pathway
18. Estrogen signaling pathway
19. Dilated cardiomyopathy (DCM)
20. Hypertrophic cardiomyopathy (HCM)
21. Circadian entrainment
22. Glucagon signaling pathway
23. Glycolysis / Gluconeogenesis
24. Phagosome
25. Salivary secretion
26. Aldosterone synthesis and secretion
27. Pancreatic secretion
28. Inflammatory mediator regulation of TRP channels
29. C-type lectin receptor signaling pathway
30. Cholinergic synapse
31. Gap junction
32. GnRH signaling pathway
33. HIF-1 signaling pathway
34. Fatty acid metabolism
35. Arrhythmogenic right ventricular cardiomyopathy (ARVC)
36. Small cell lung cancer
37. Adipocytokine signaling pathway
38. Amphetamine addiction
39. Gastric acid secretion
40. Glycine, serine and threonine metabolism
41. Arginine and proline metabolism
42. Ferroptosis
43. Cysteine and methionine metabolism
44. Pyruvate metabolism
45. Fatty acid degradation
46. Biosynthesis of unsaturated fatty acids
47. Citrate cycle (TCA cycle)
48. Pentose phosphate pathway
49. Glyoxylate and dicarboxylate metabolism
50. Mucin type O-glycan biosynthesis
51. Propanoate metabolism
52. Proximal tubule bicarbonate reclamation

FOCAL ADHESION

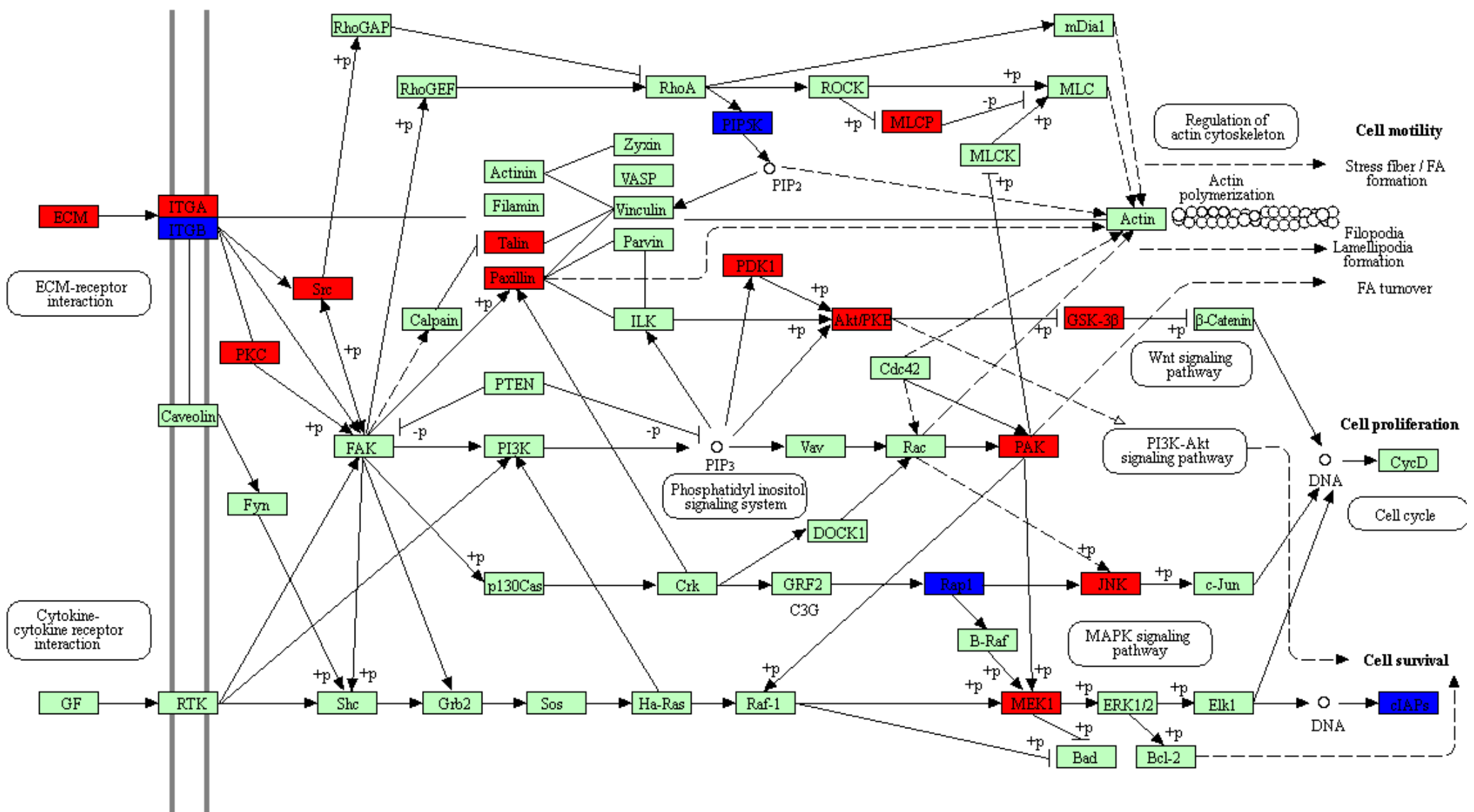

PLATELET ACTIVATION

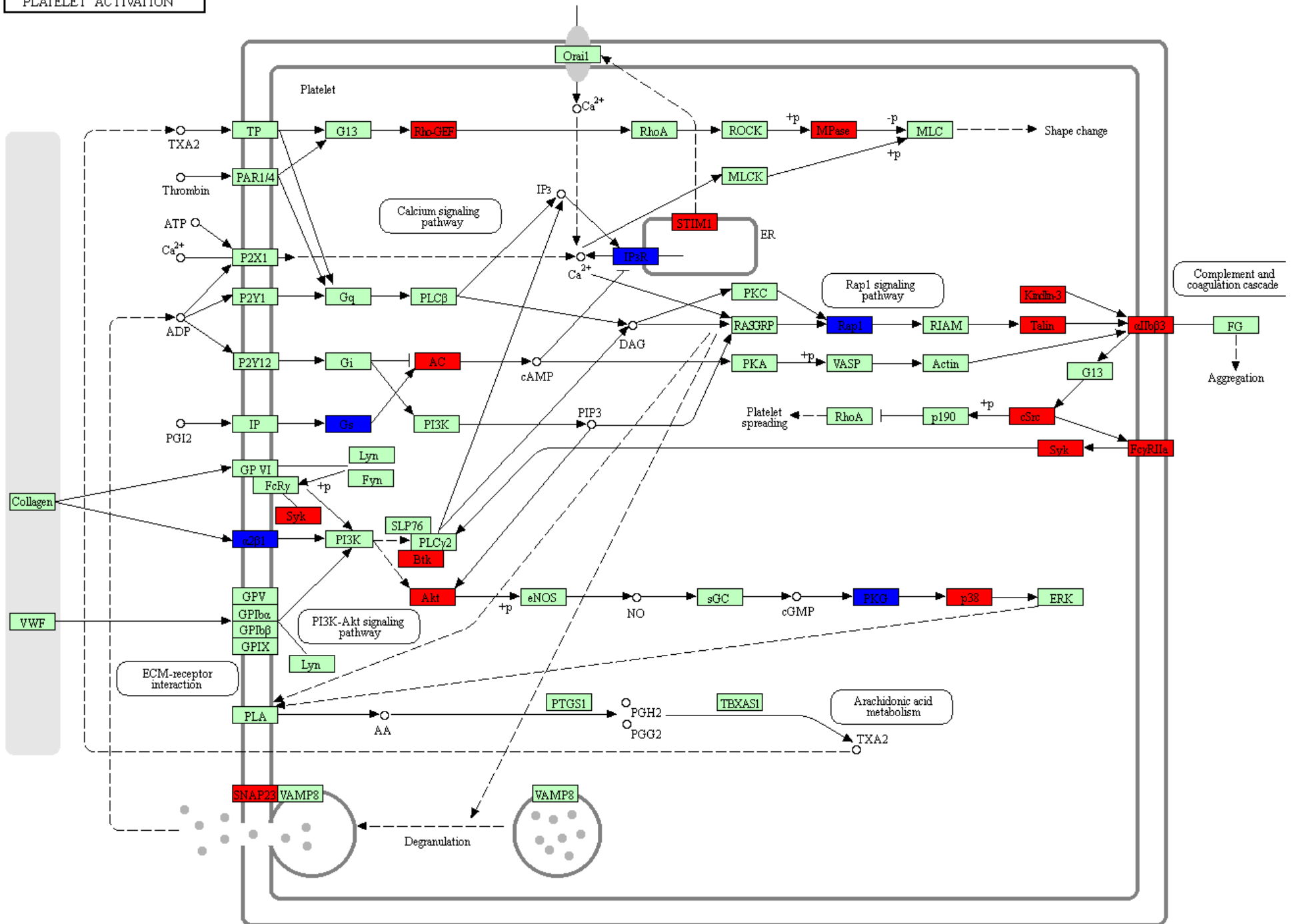

DOPAMINERGIC SYNAPSE

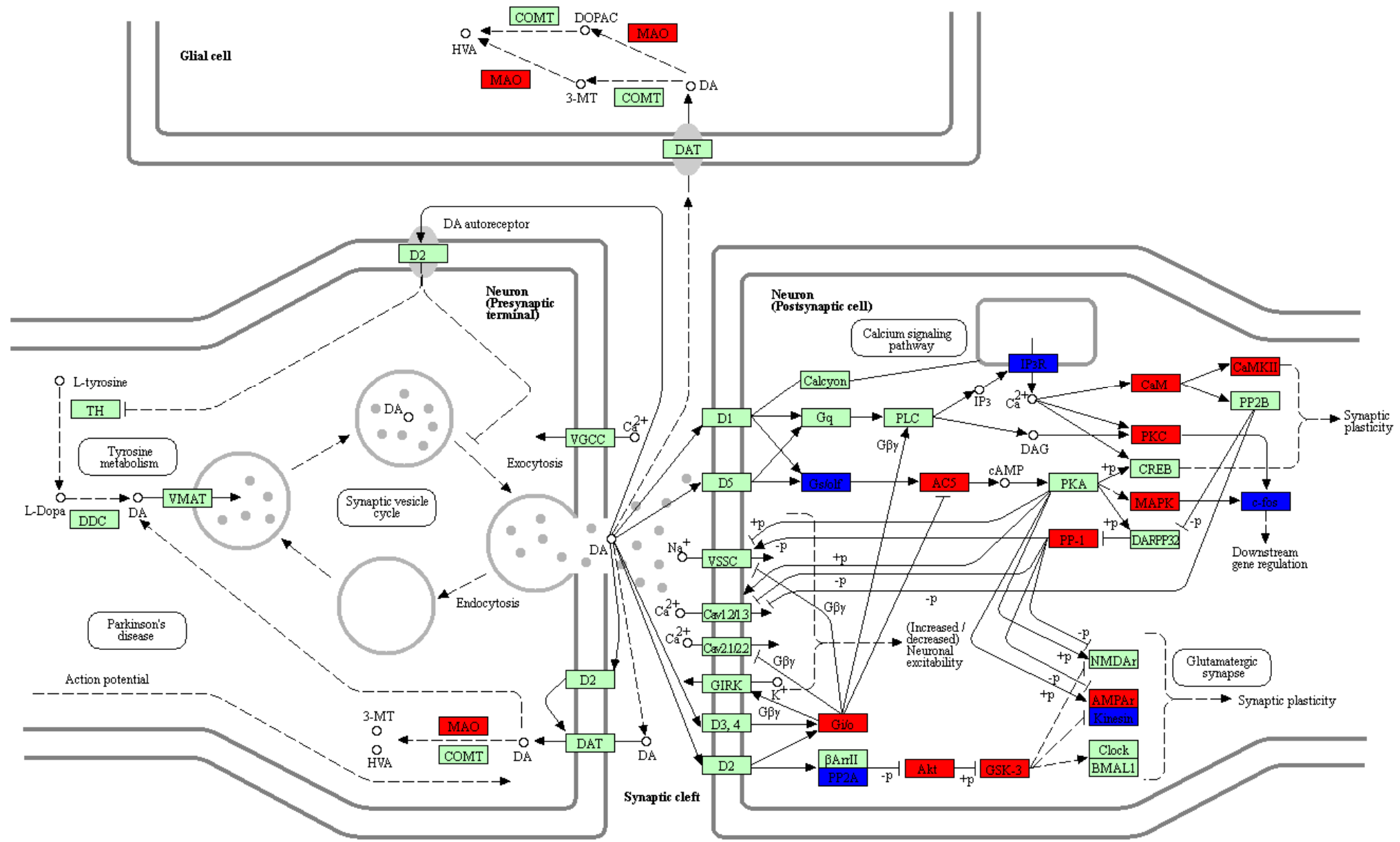

HUMAN CYTOMEGALOVIRUS INFECTION

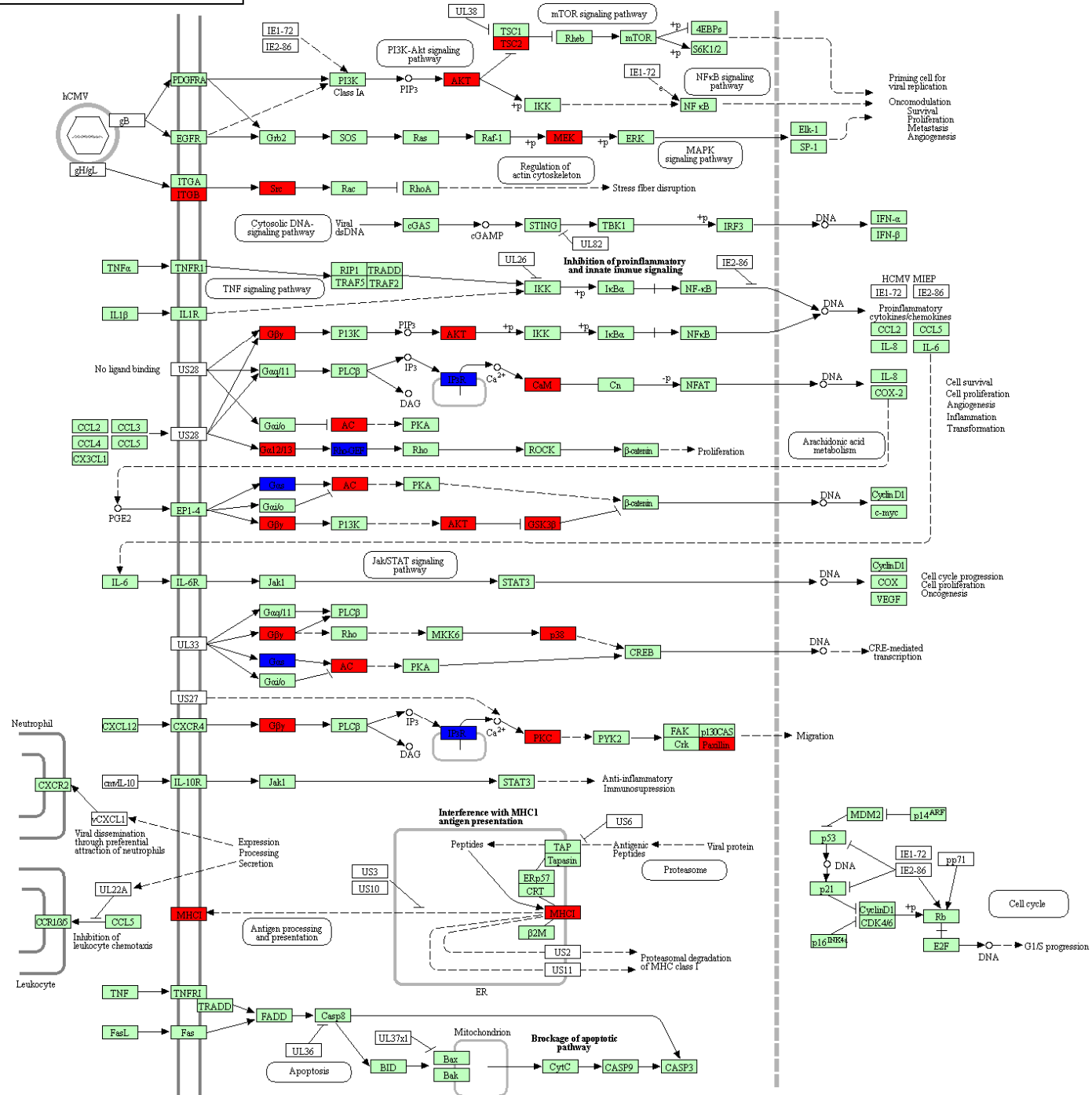

PROTEOGLYCAN IN CANCER

Hyaluronan (HA)

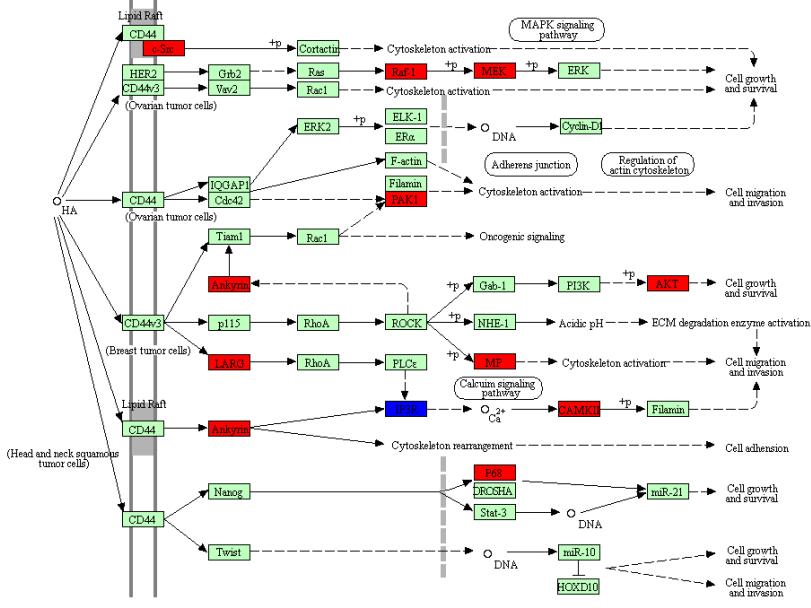

Chondroitin sulfate/ Dermatan sulfate proteoglycan (CSPG/DSPG)

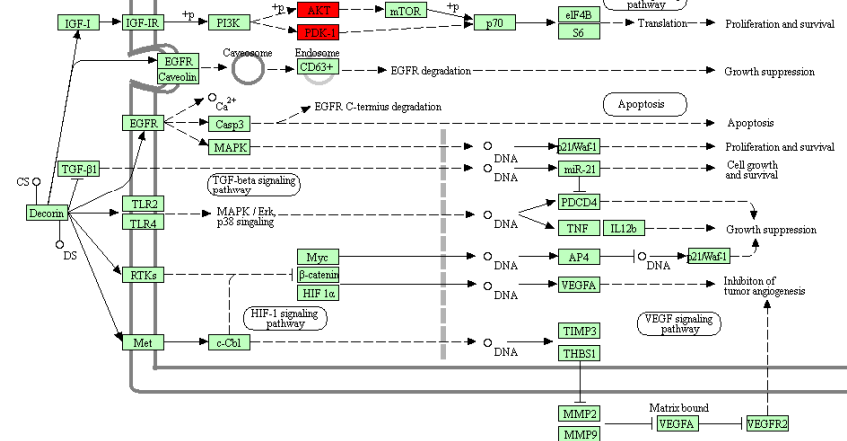

Keratan sulfate proteoglycan (KSPG)

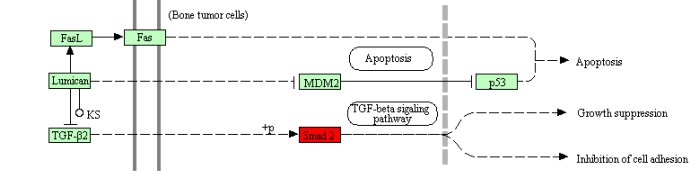

Heparan sulfate proteoglycans (HSPGs)

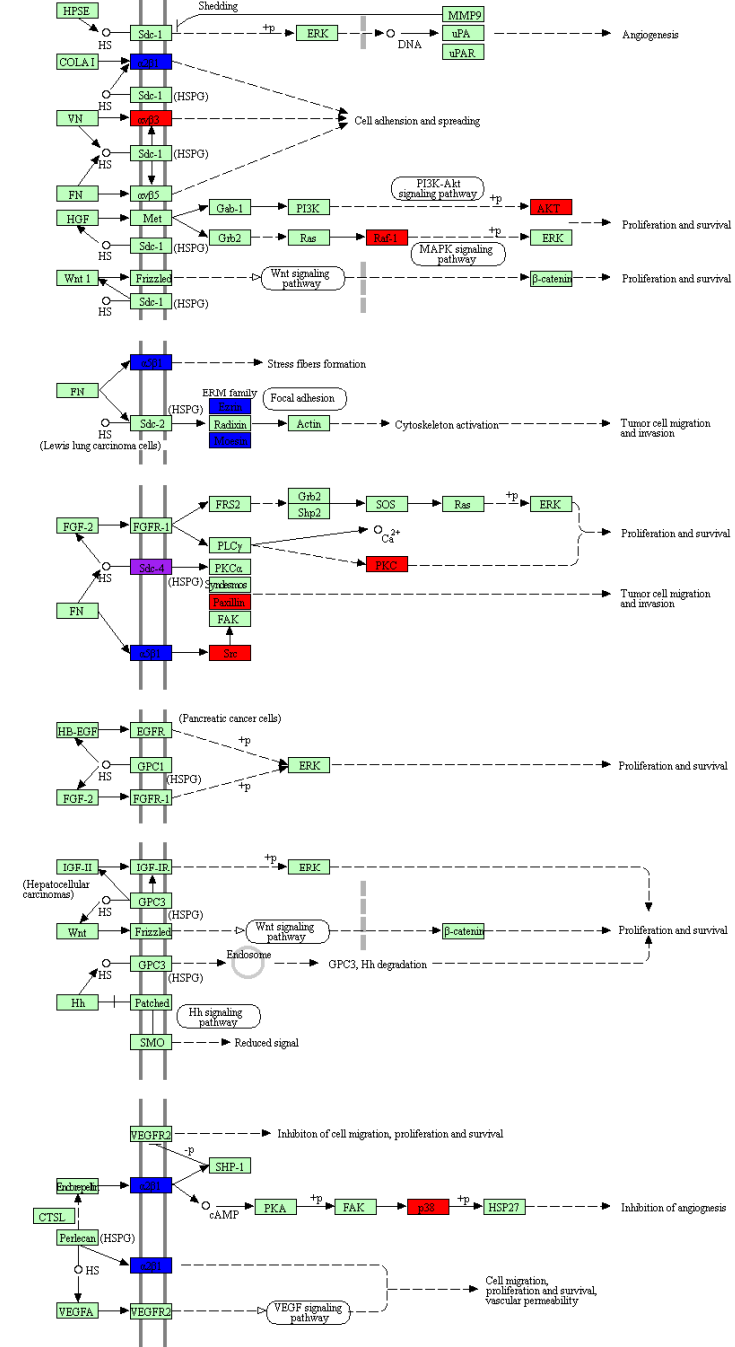

REGULATION OF ACTIN CYTOSKELETON

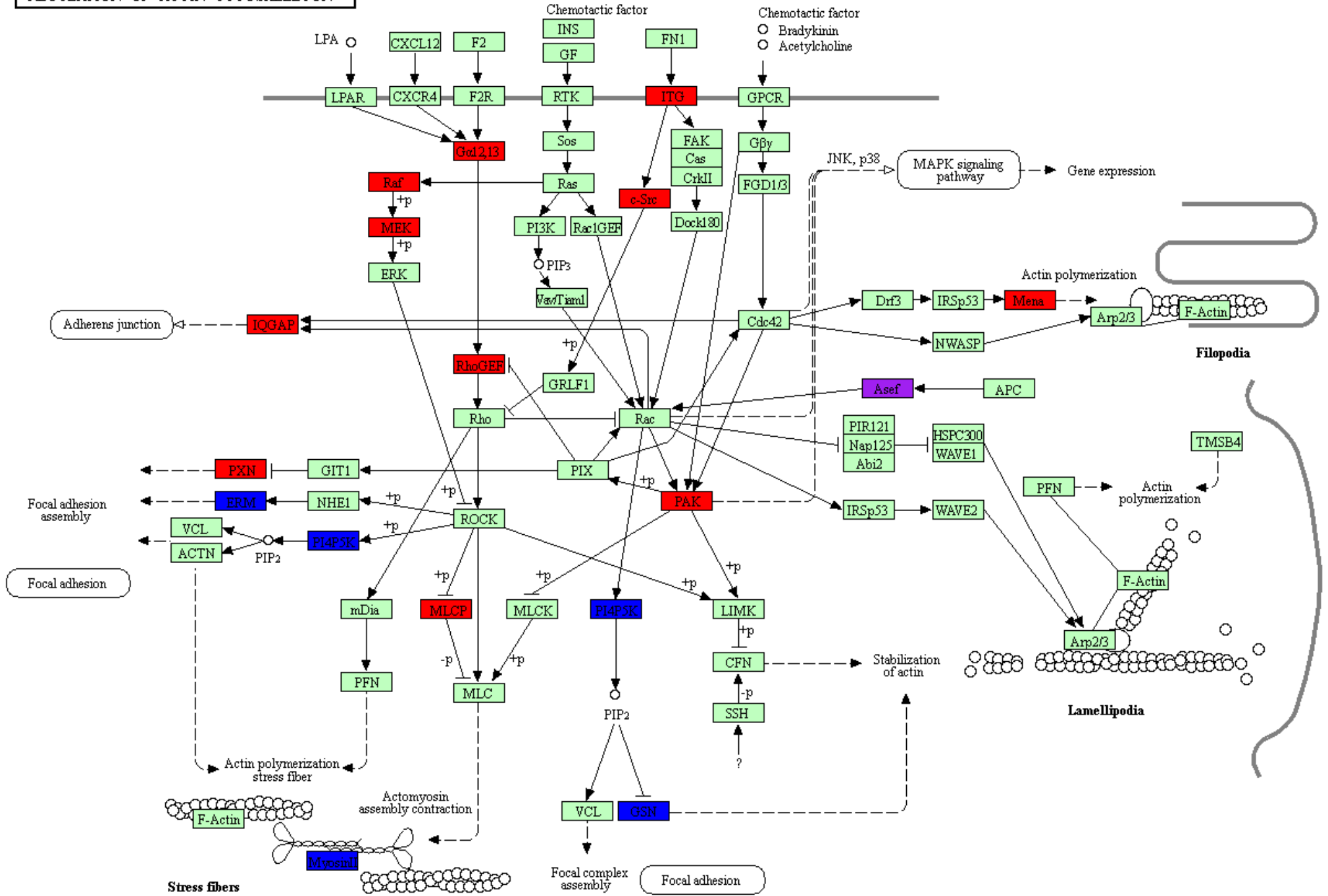

cGMP-PKG SIGNALING PATHWAY

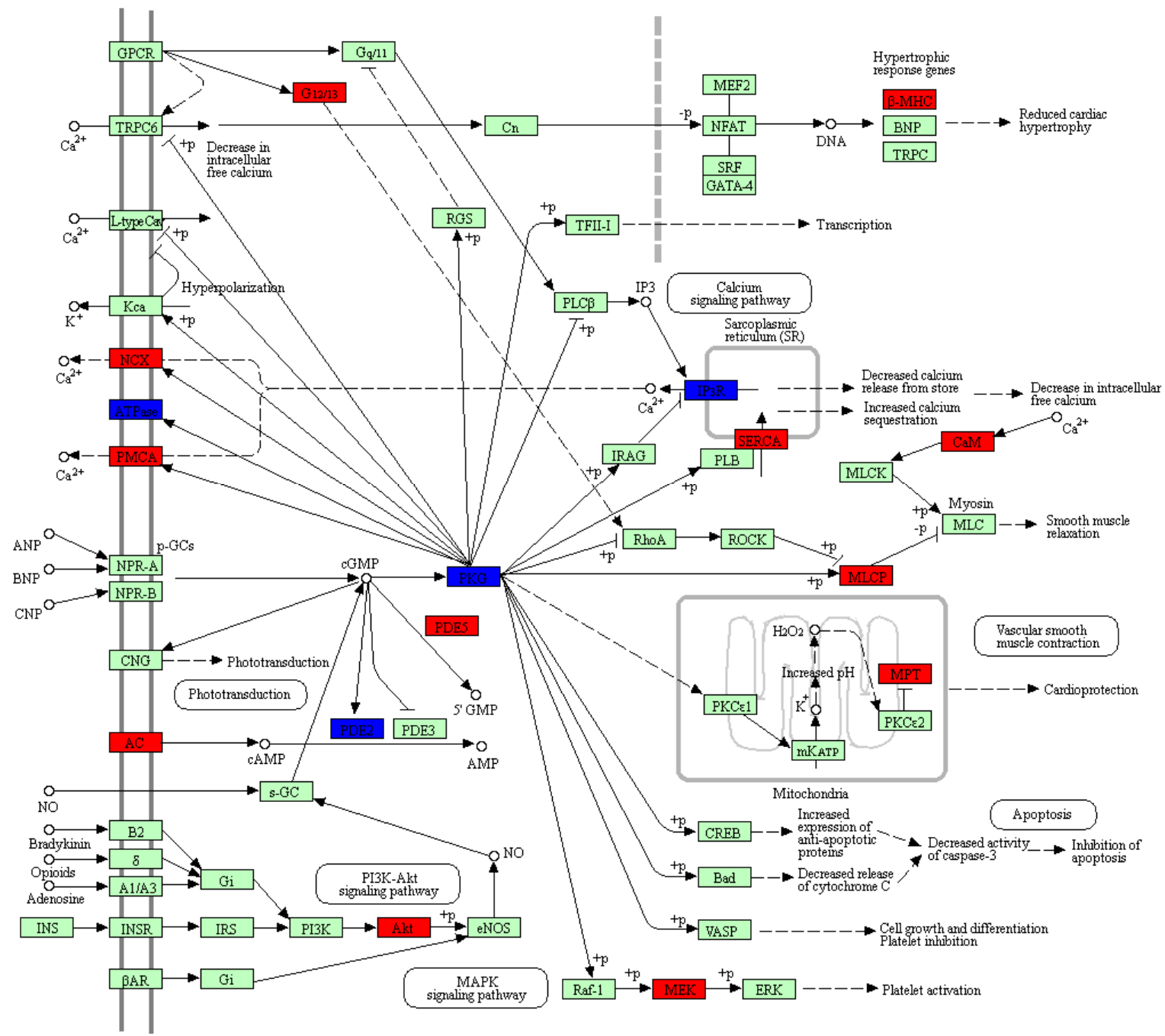

RETROGRADE ENDOCANNABINOID SIGNALING

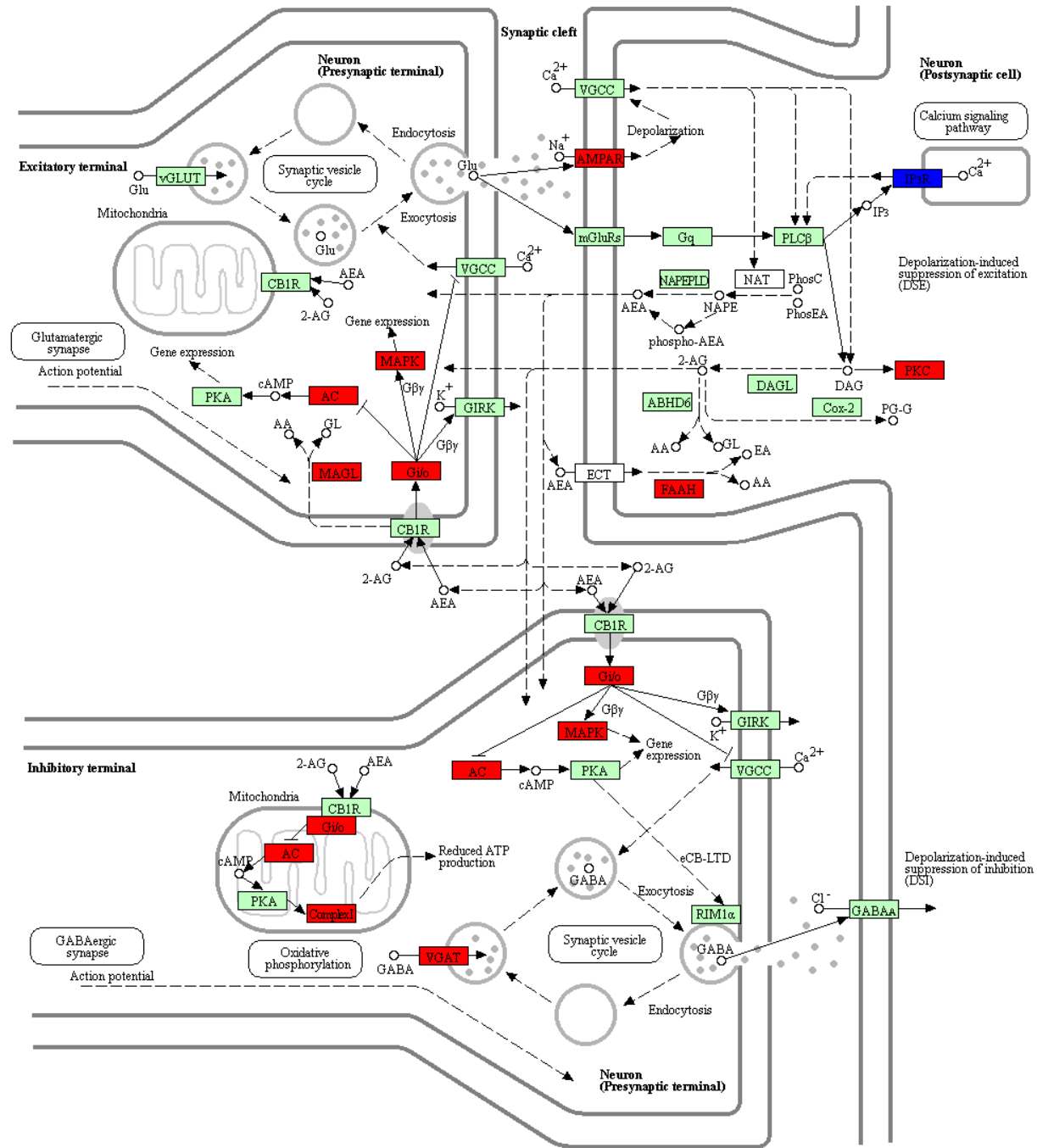

HORMONE SIGNALING PATHWAY

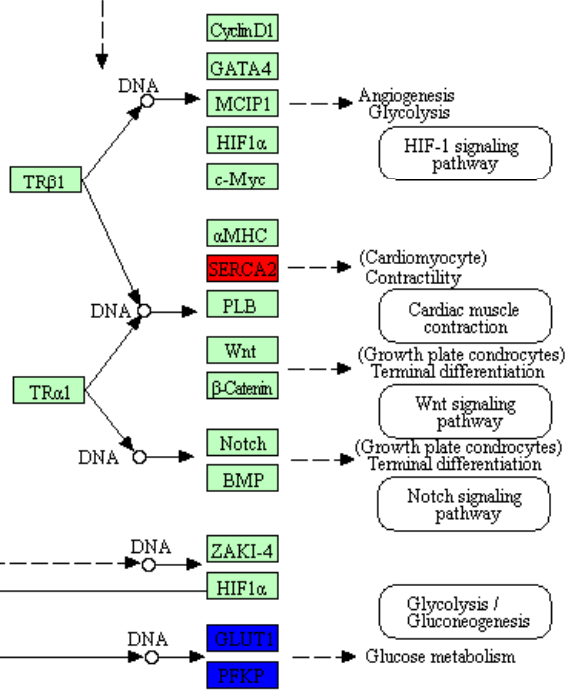
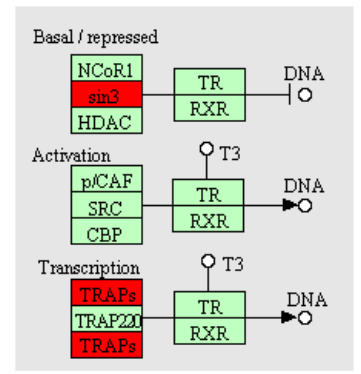
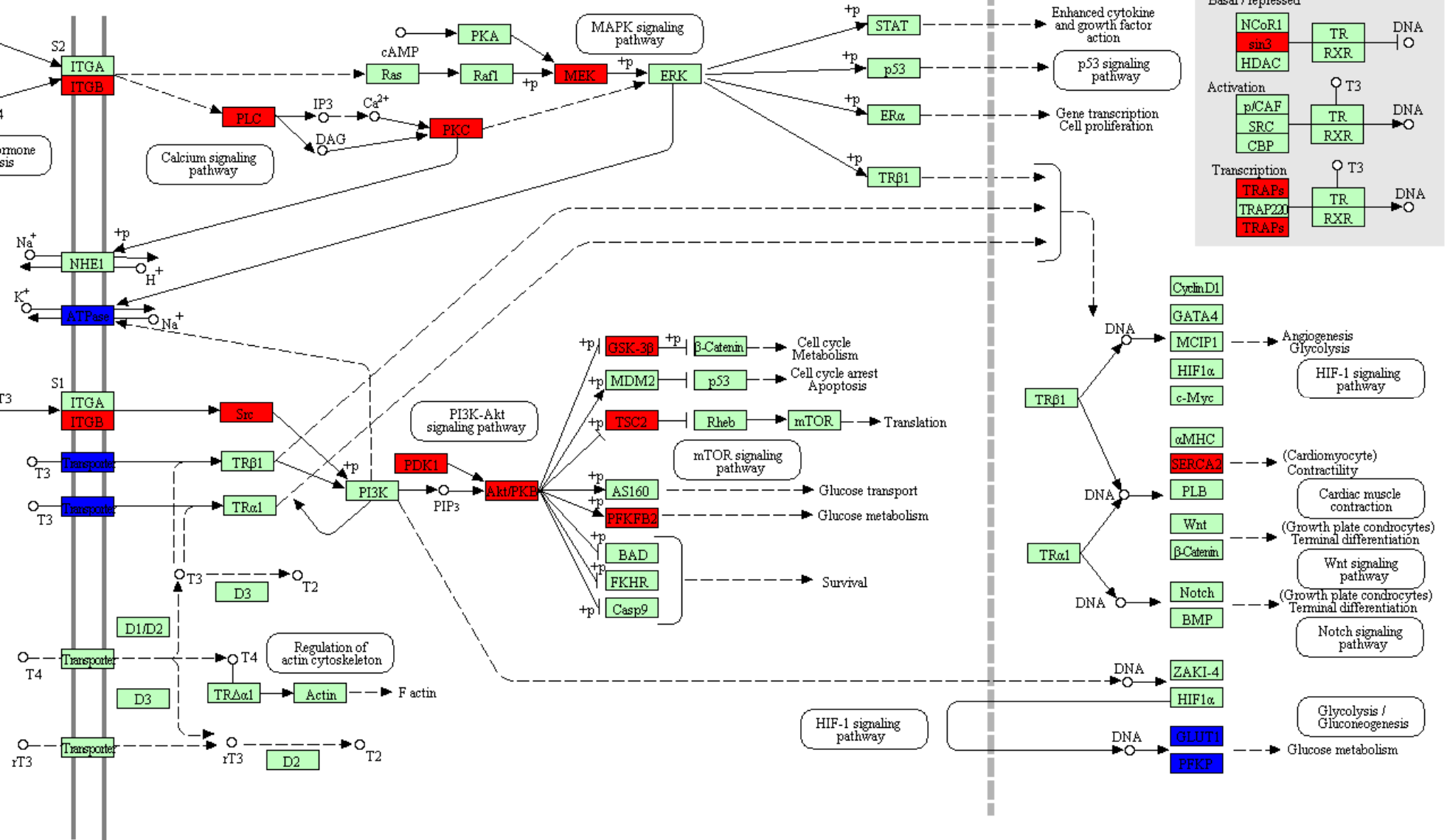

ADRENERGIC SIGNALING IN CARDIOMYOCYTES

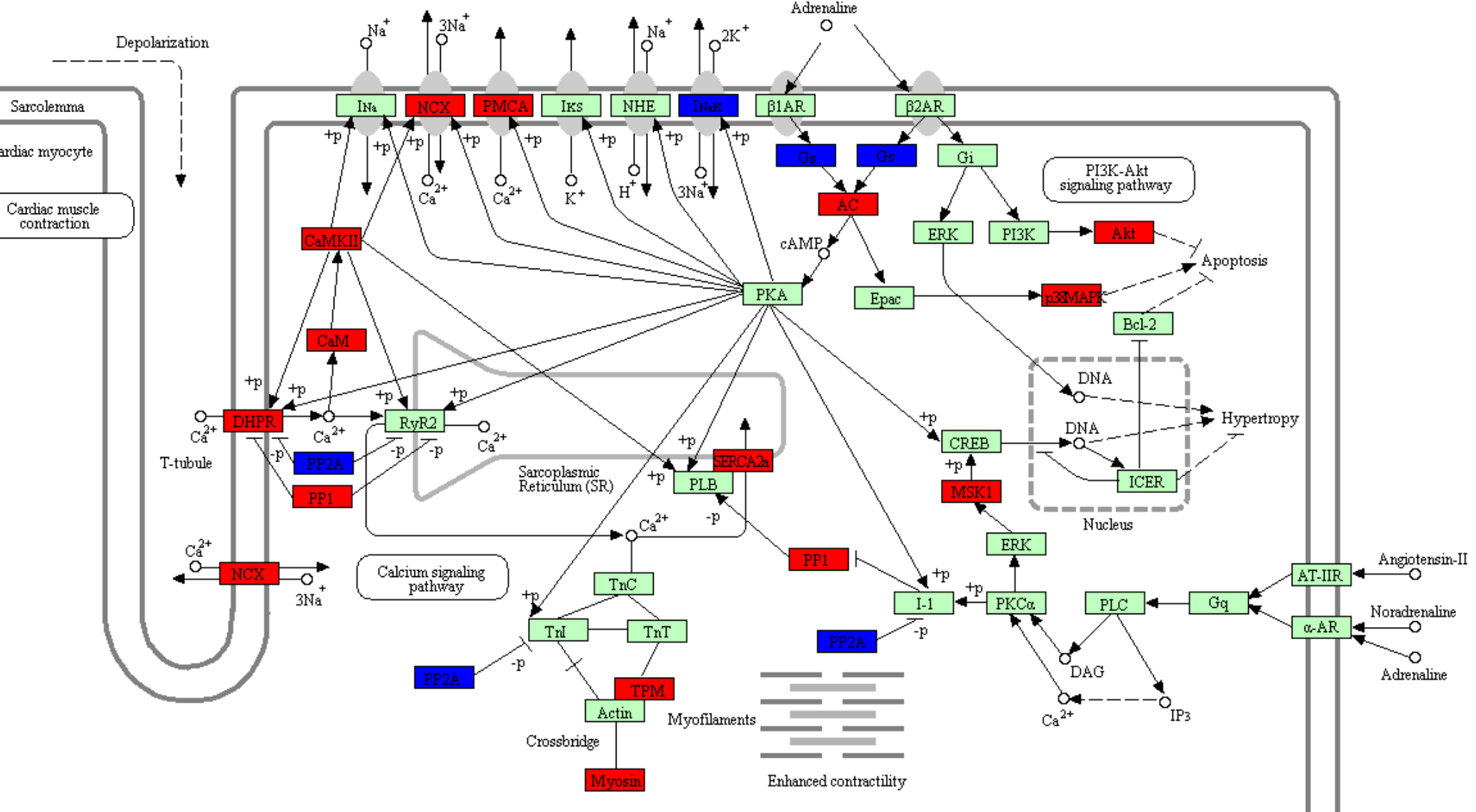

PHAGOSOME

Conventional phagocytosis

ER-mediated phagocytosis

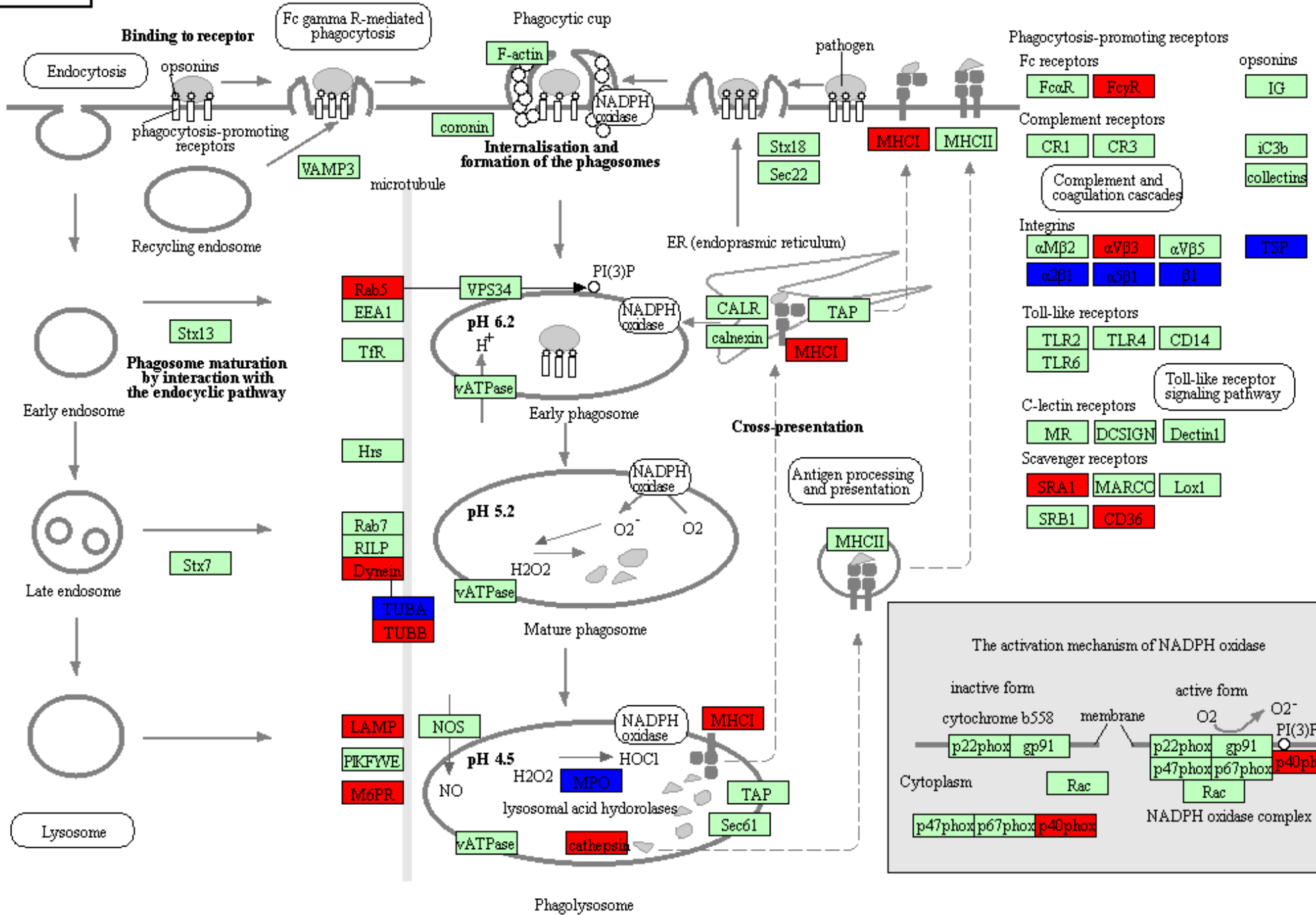

ECM-RECEPTOR INTERACTION

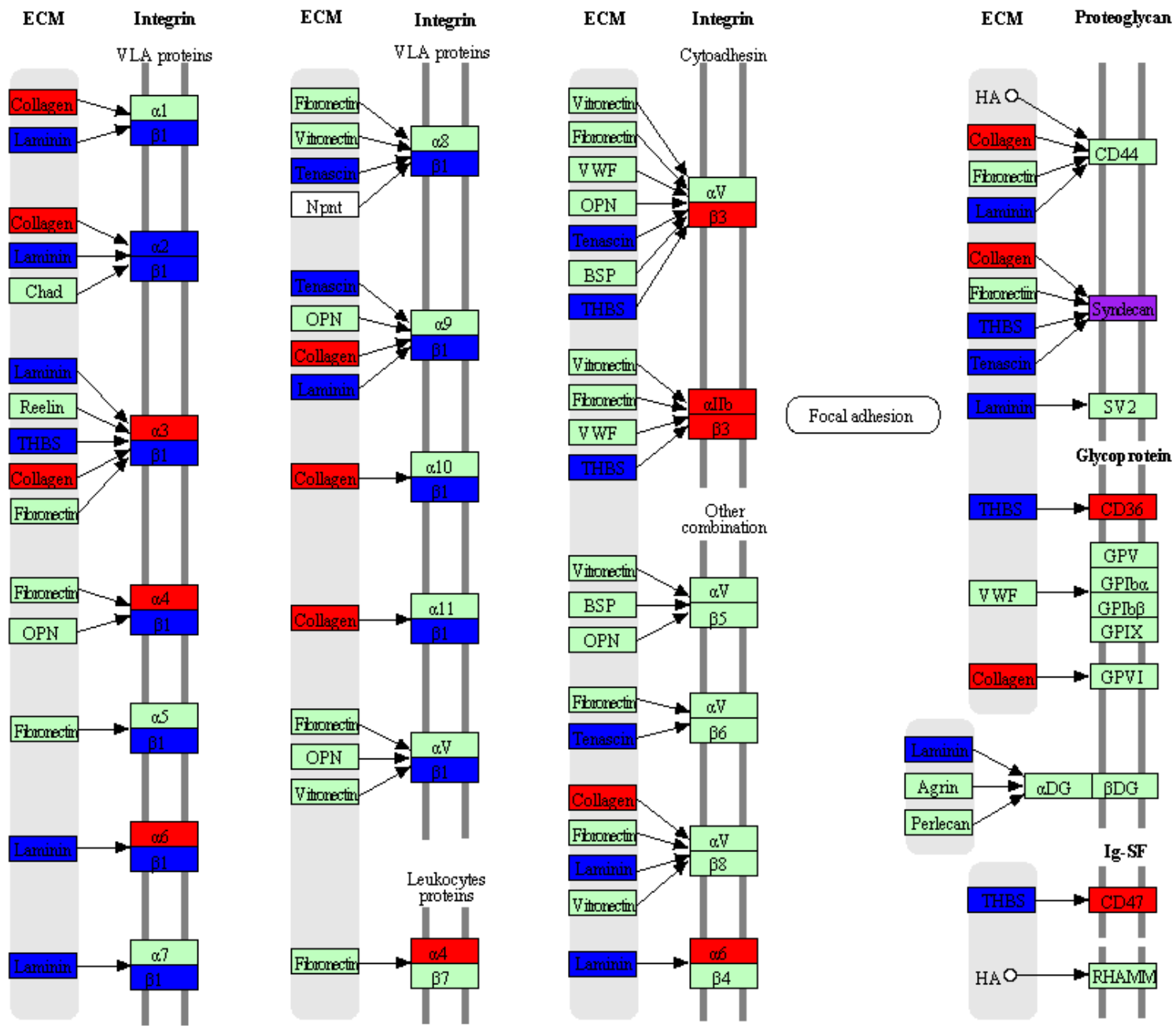

INSULIN SIGNALING PATHWAY

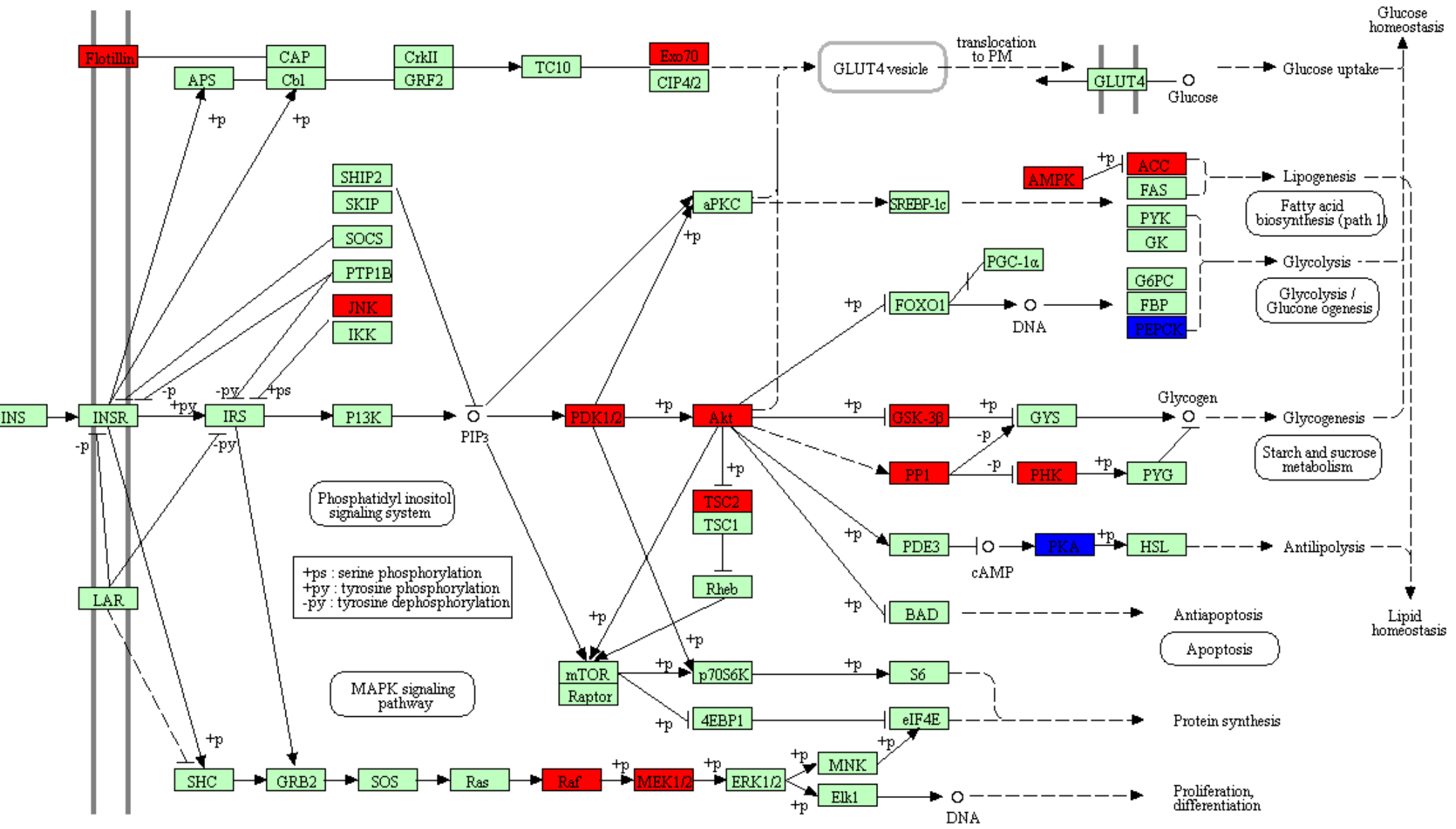

PPAR SIGNALING PATHWAY

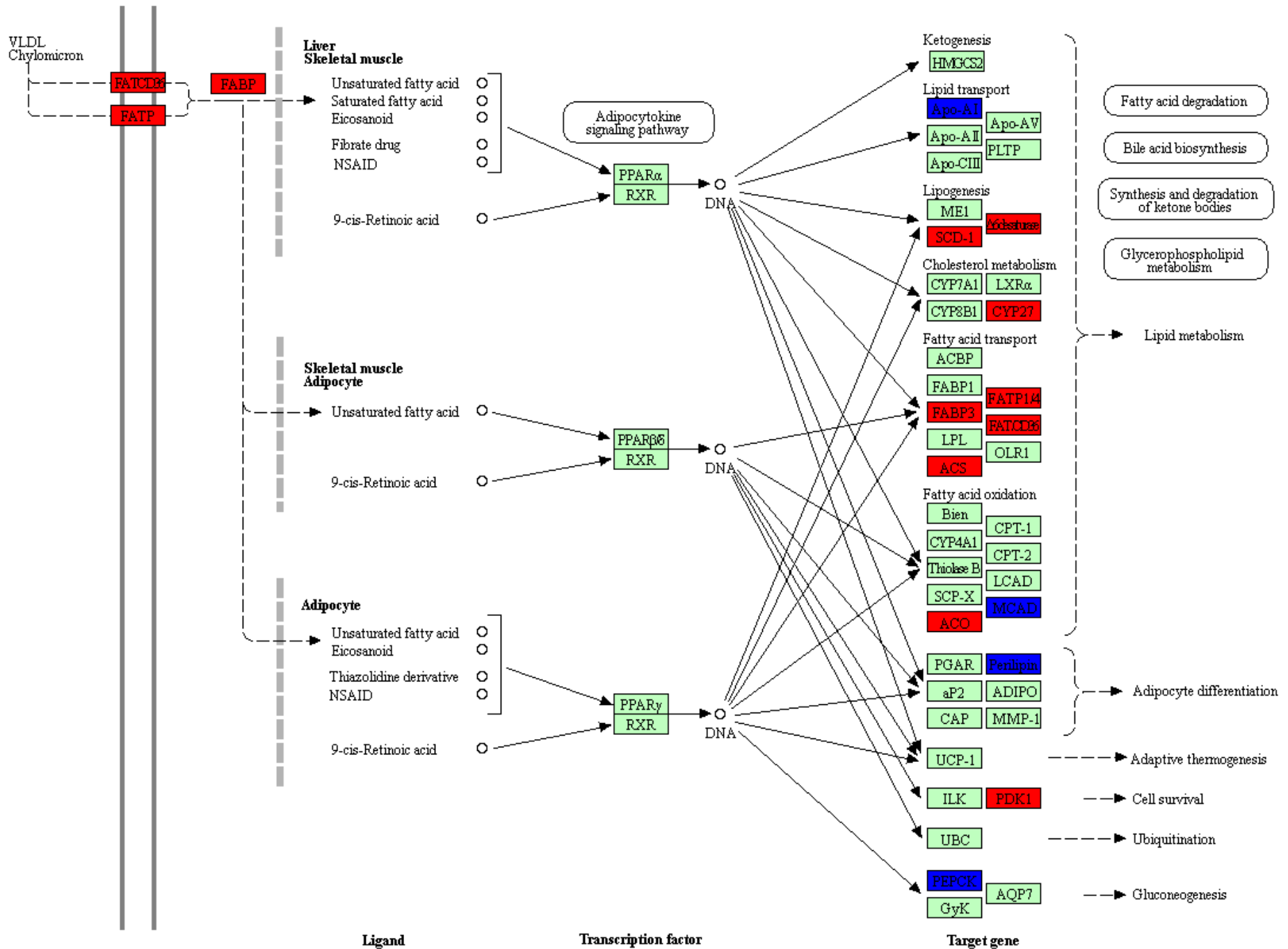

NEUROTROPHIN SIGNALING PATHWAY

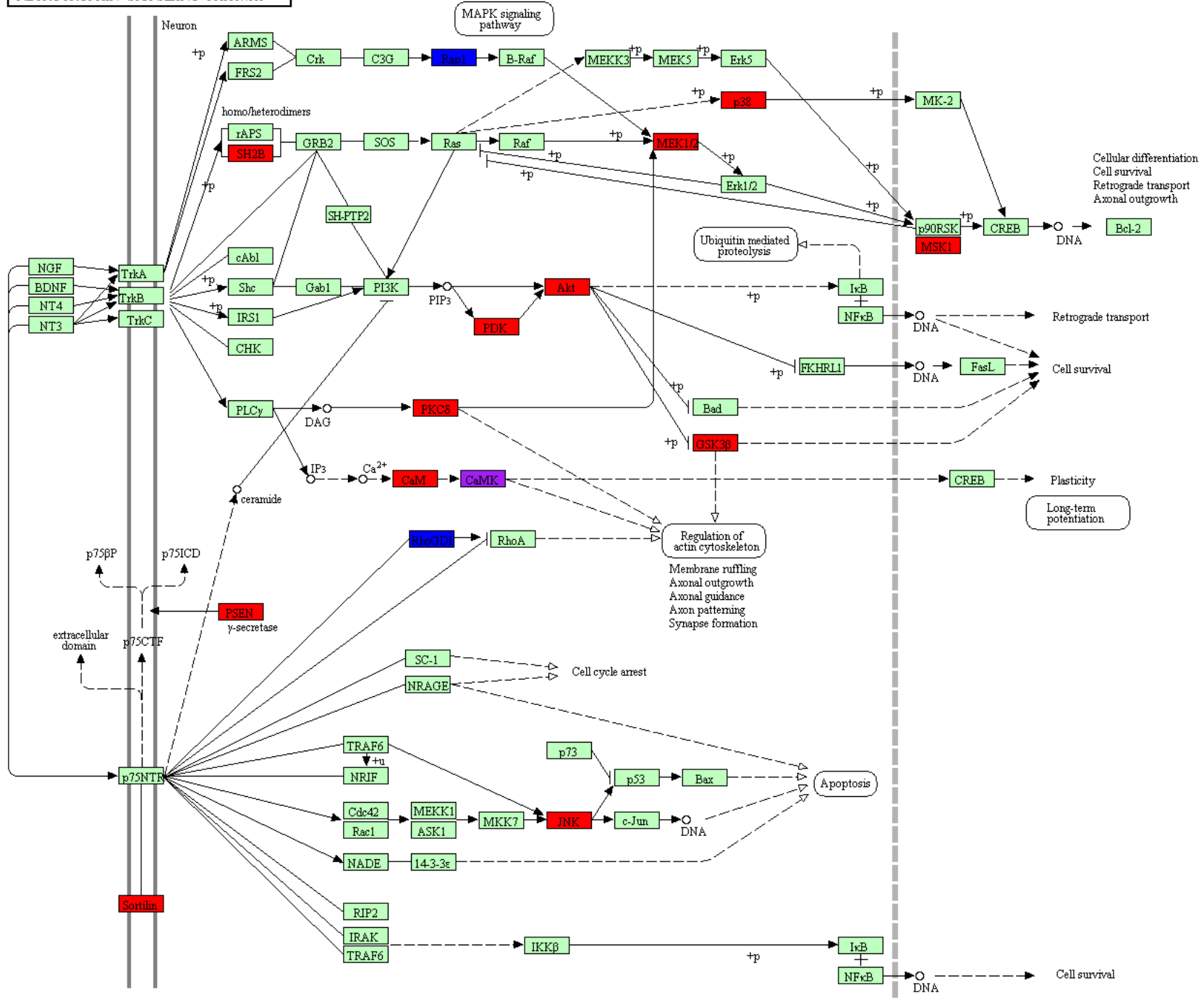

ESTROGEN SIGNALING PATHWAY

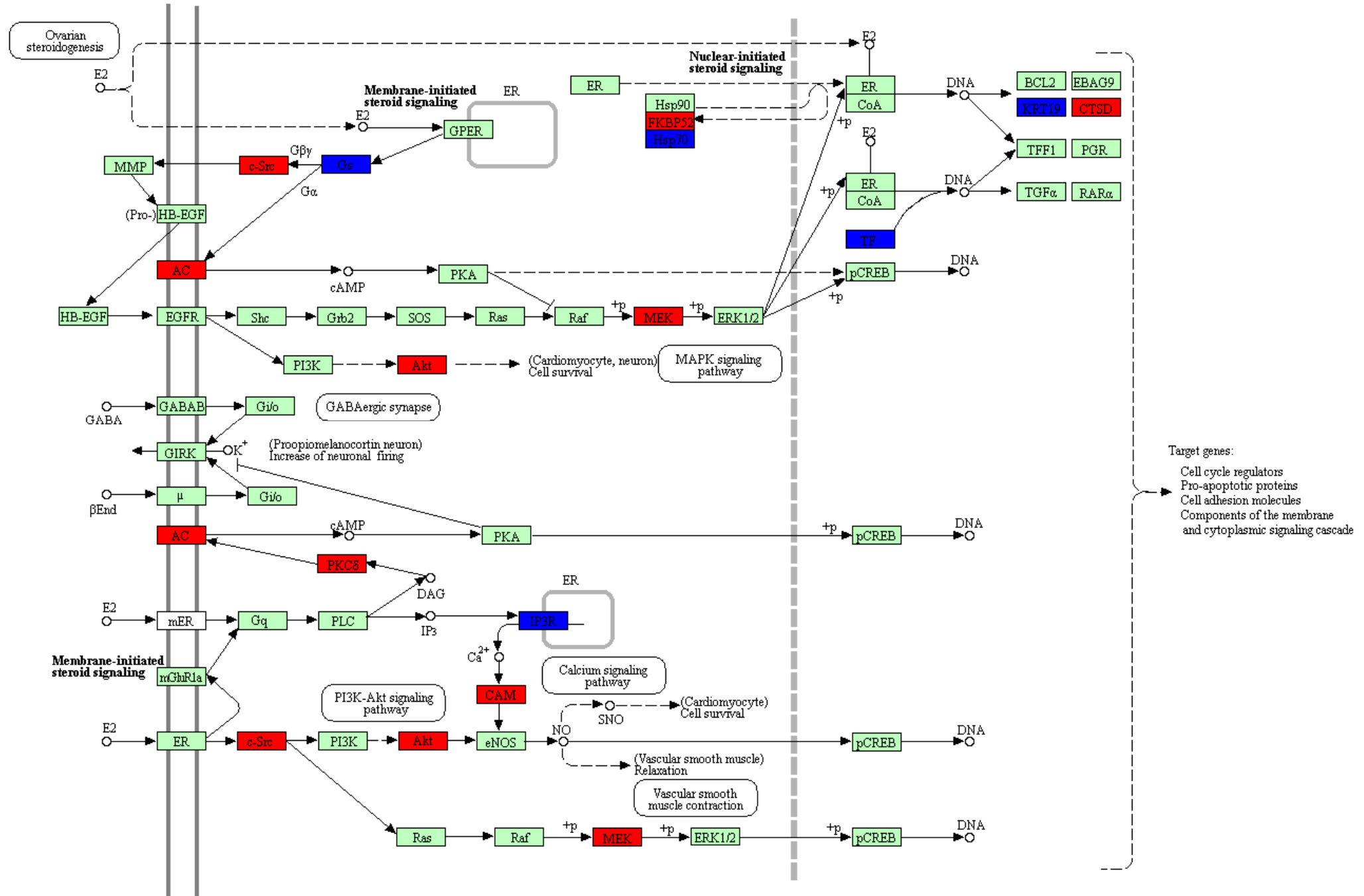

DILATED CARDIOMYOPATHY (DCM)

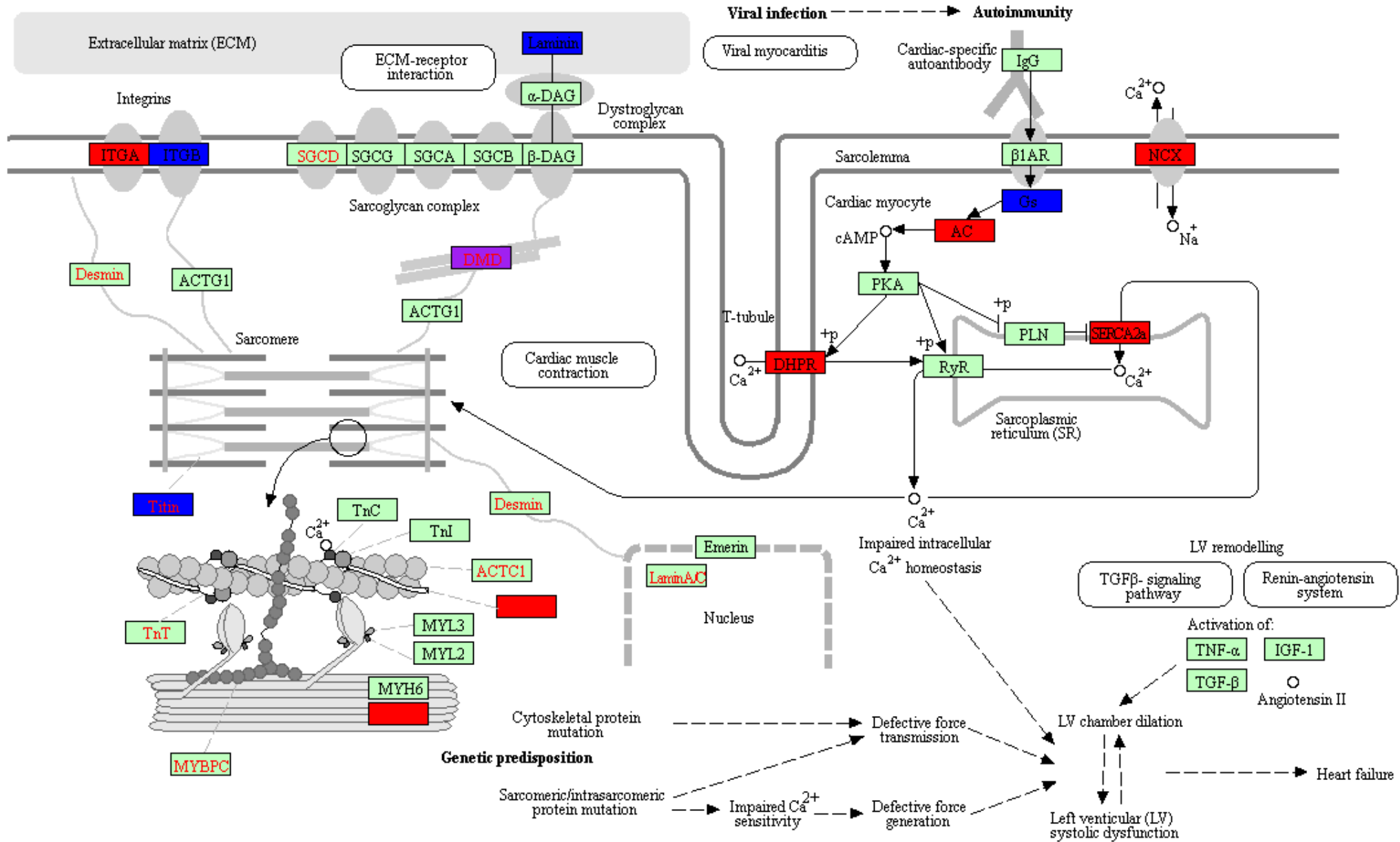

HYPERTROPHIC CARDIOMYOPATHY (HCM)

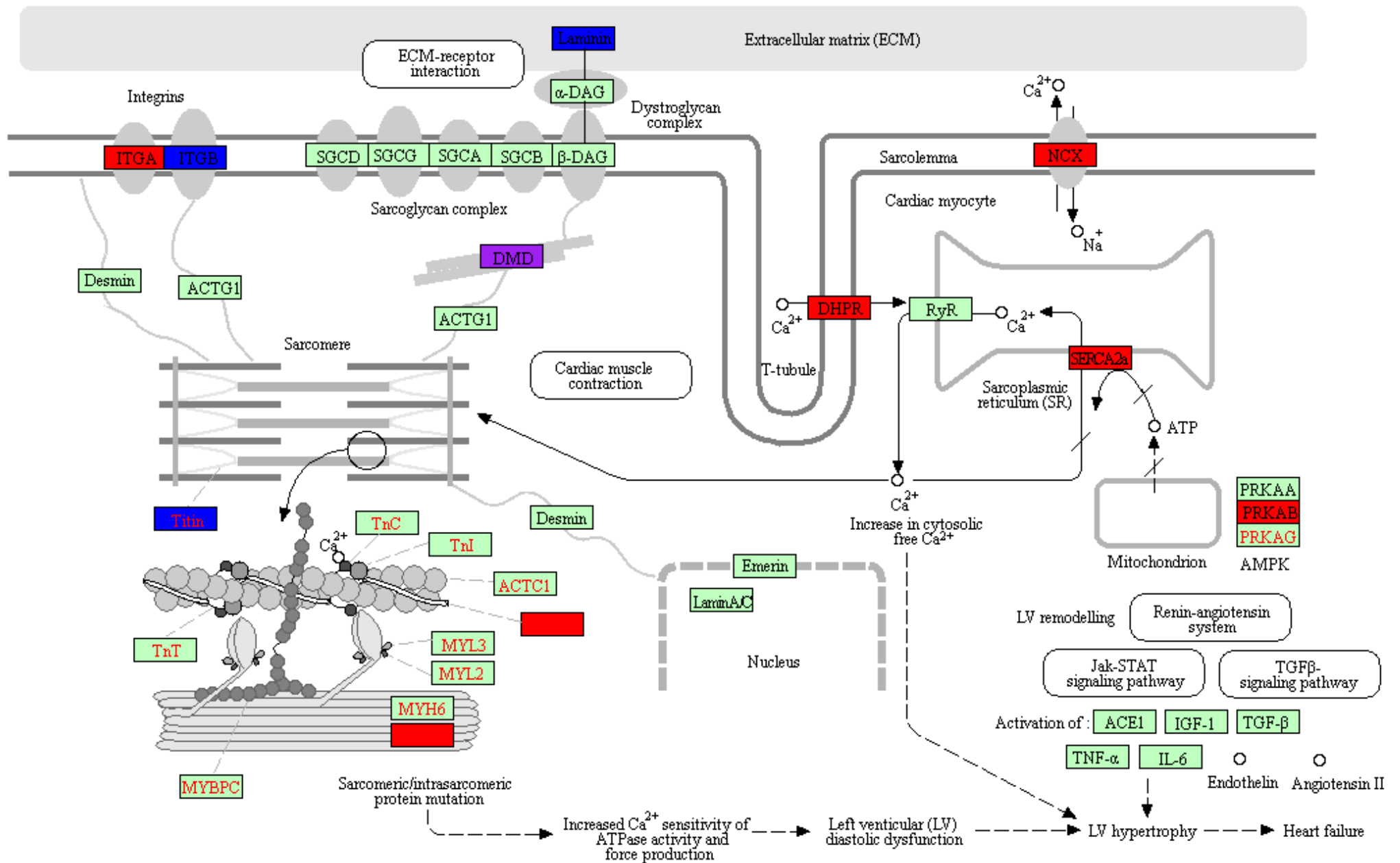

CIRCADIAN ENTRAINMENT

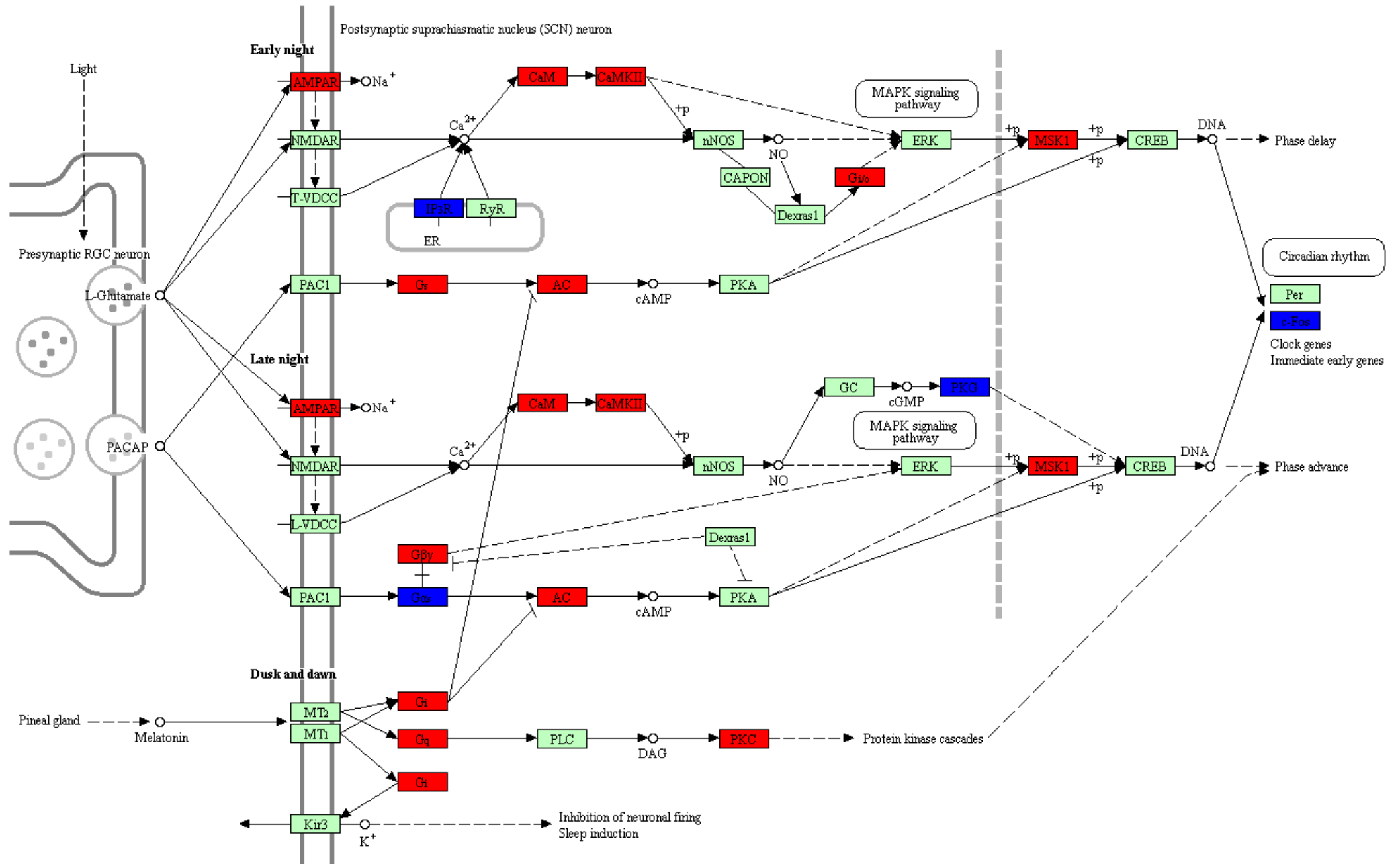

GLUCAGON SIGNALING PATHWAY

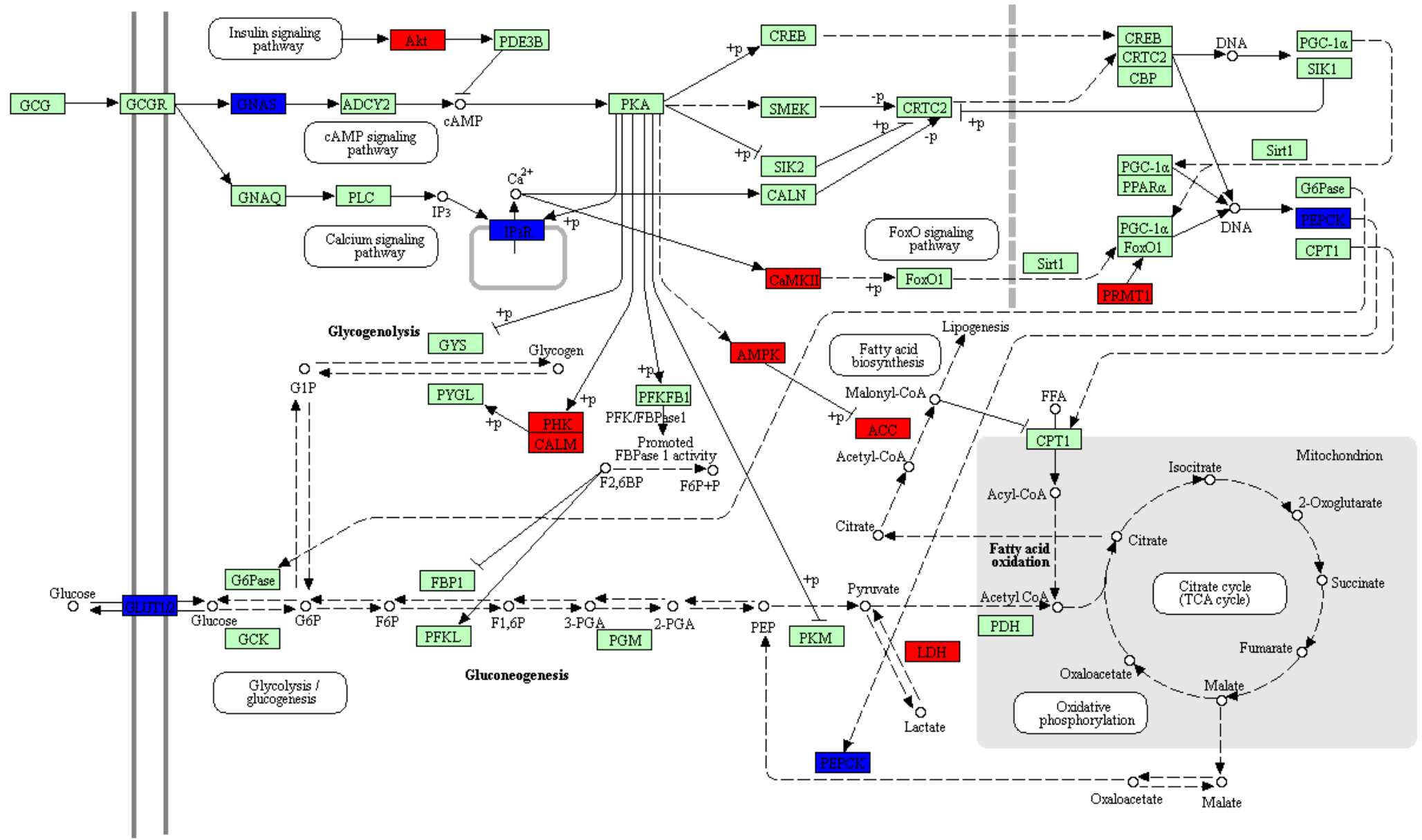

SALIVARY SECRETION

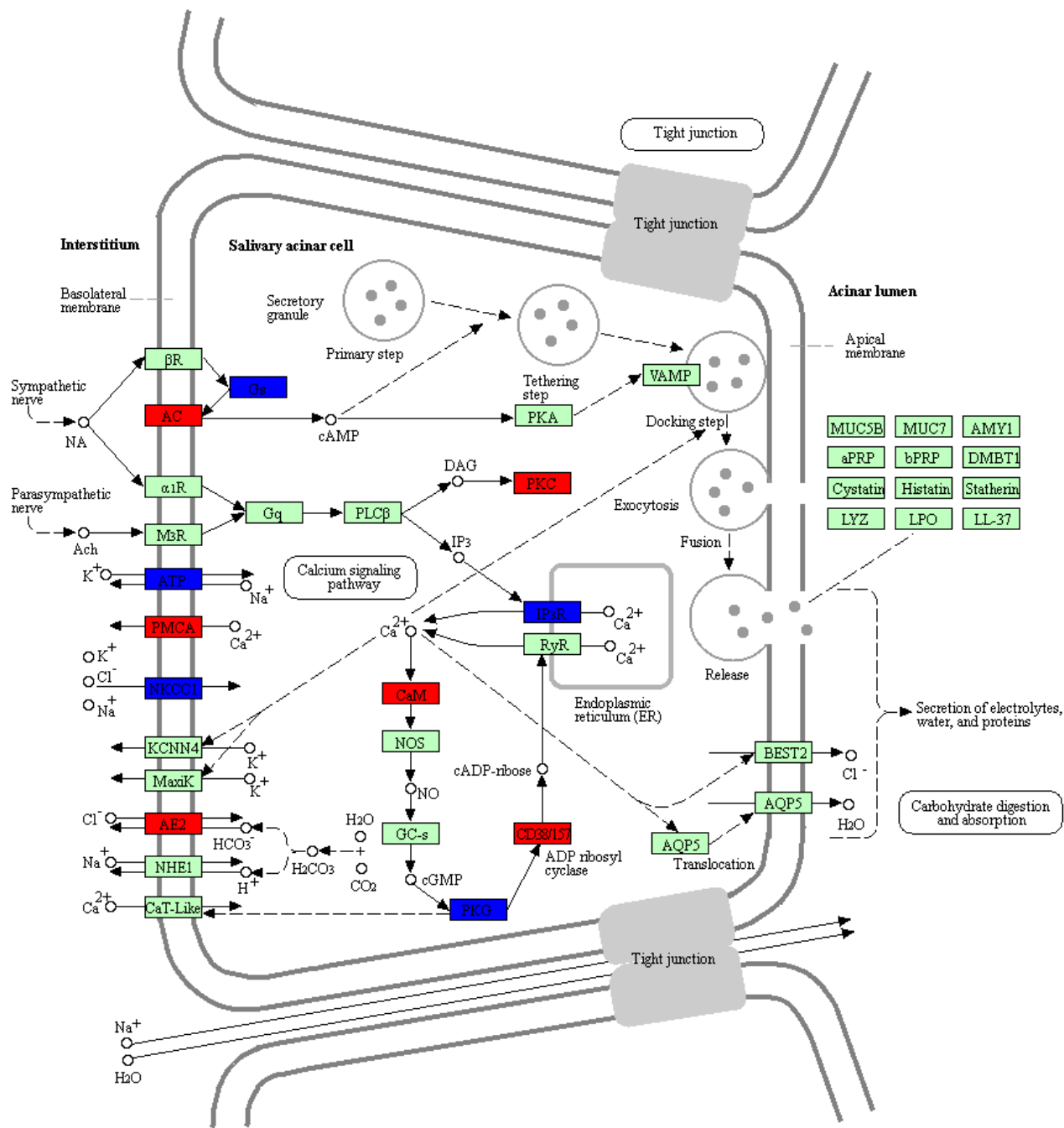

ALDOSTERONE SYNTHESIS AND SECRETION

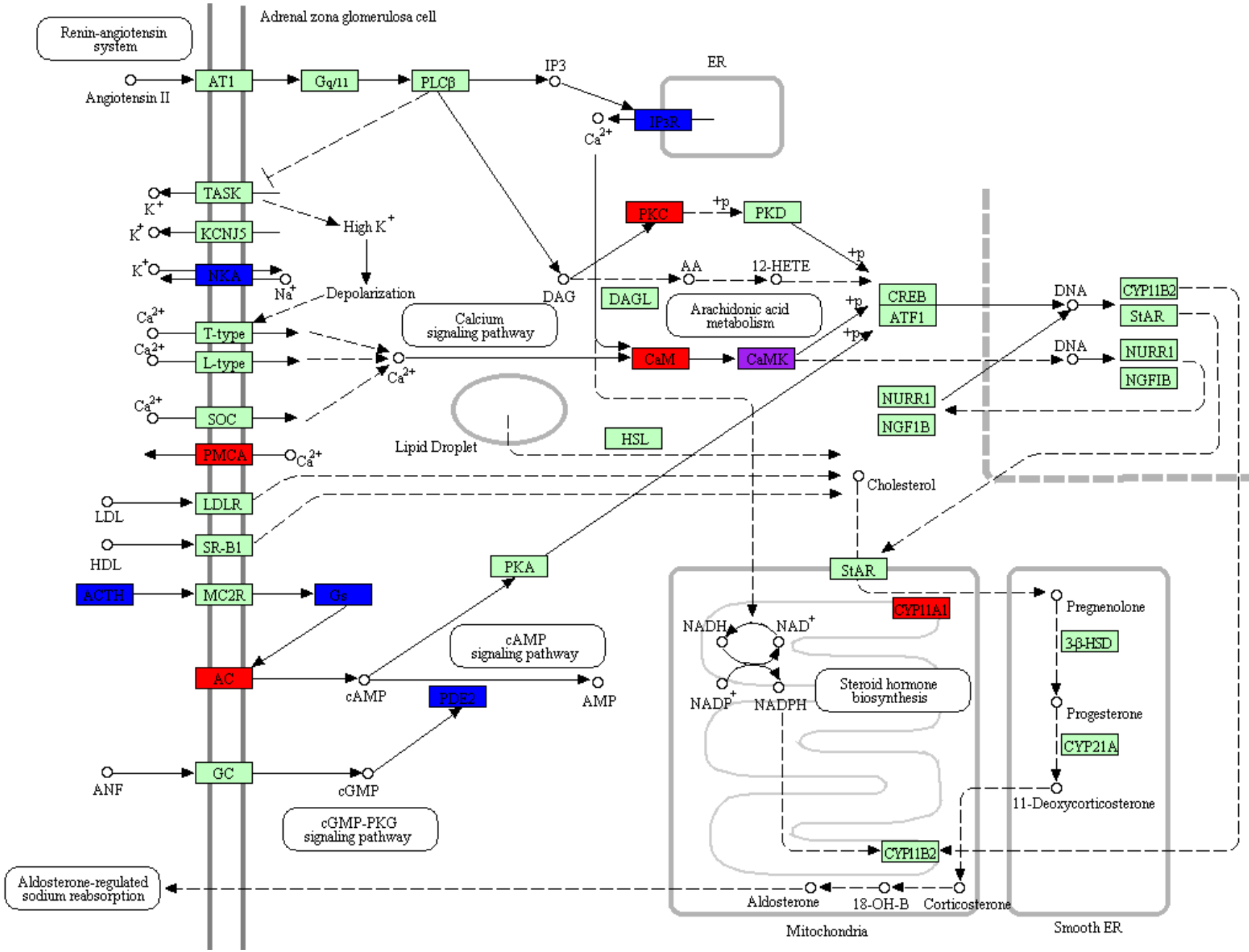

PANCREATIC SECRETION

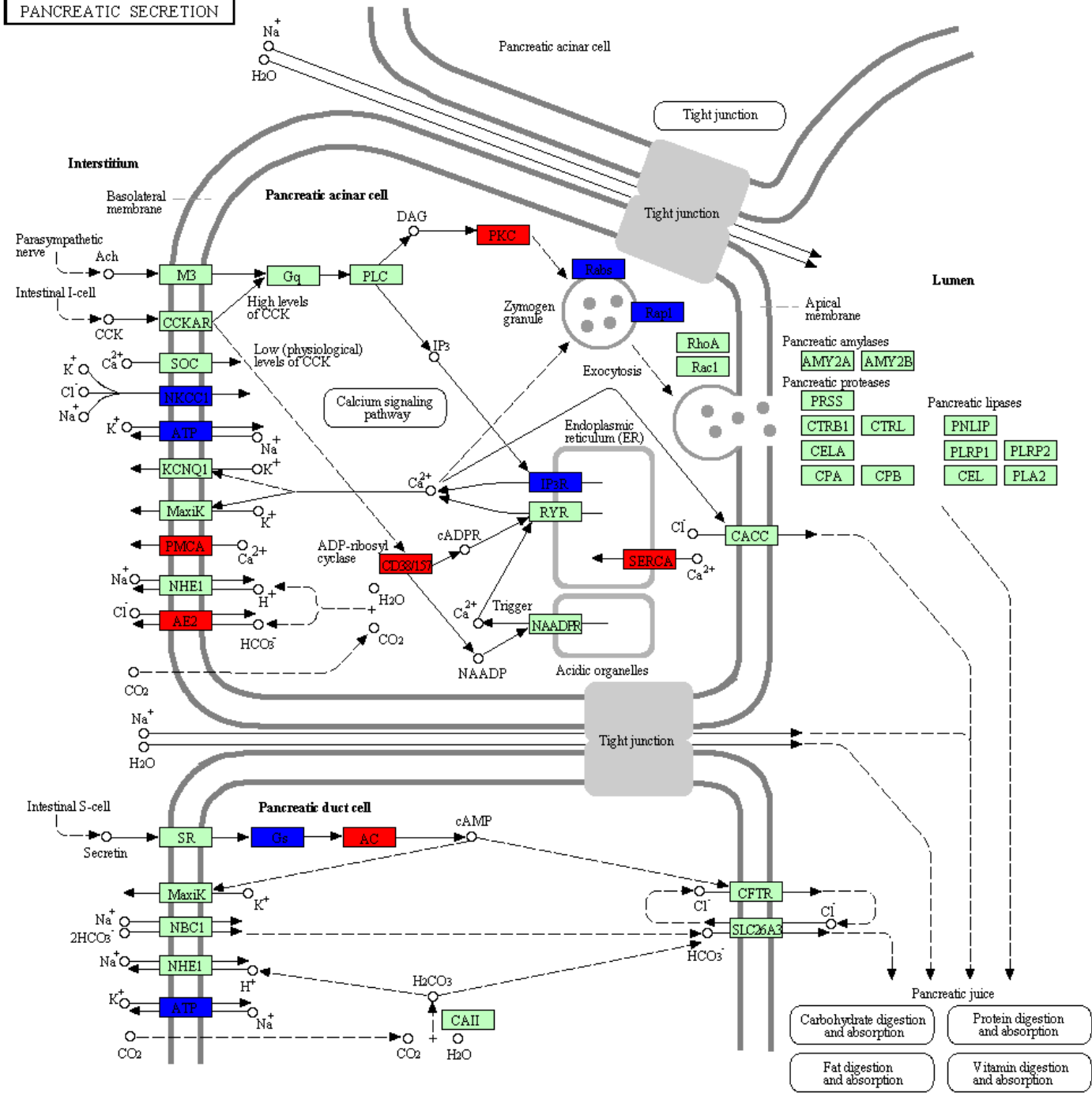

INFLAMMATORY MEDIATOR REGULATION OF TRP CHANNELS

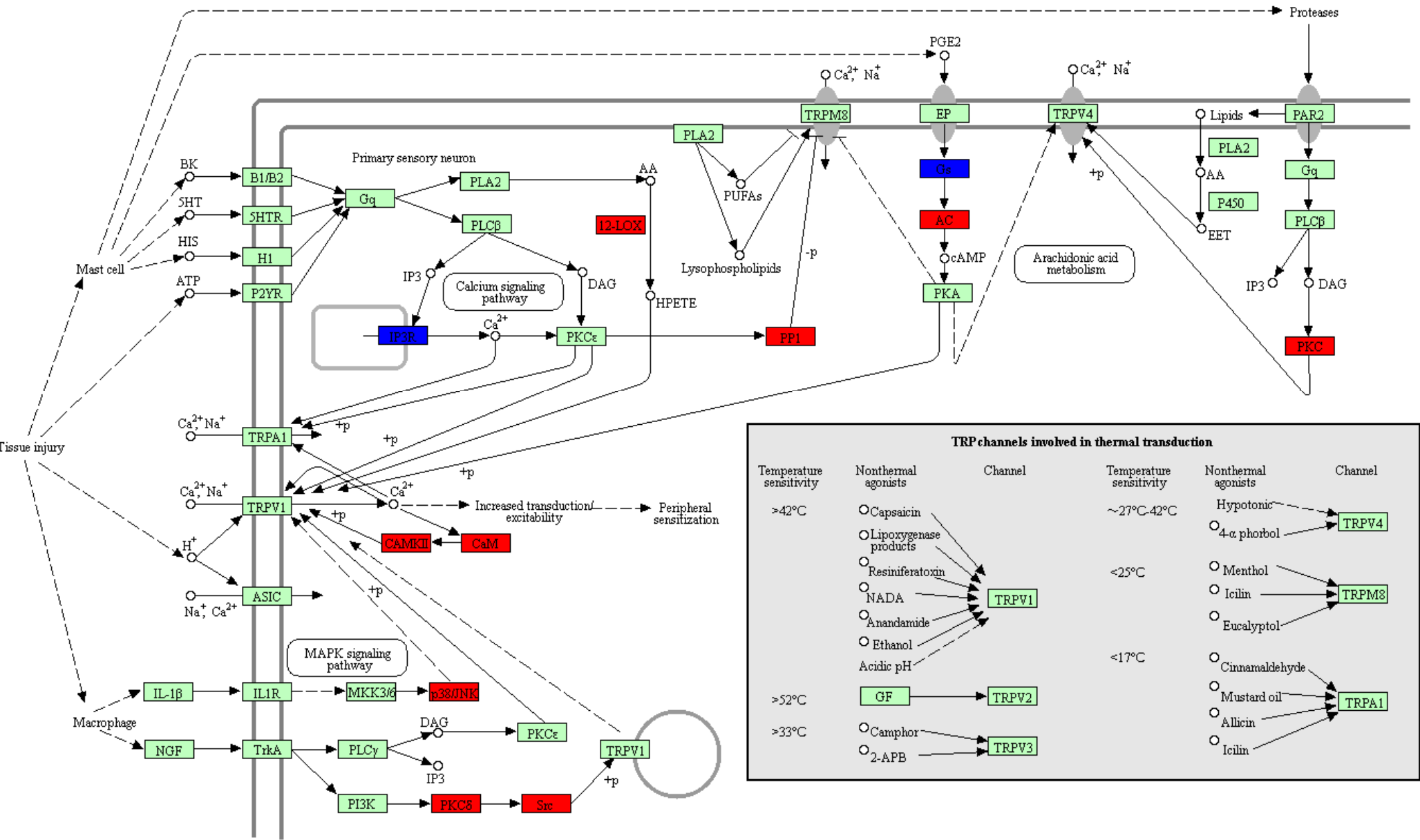

TRP channels involved in thermal transduction

Temperature sensitivity	Nonthermal agonists	Channel	Temperature sensitivity	Nonthermal agonists	Channel	
>42°C	○ Capsaicin	TRPV1	~27°C-42°C	○ Hypotonic	TRPV4	
	○ Lipoxygenase products			○ 4-α phorbol		
	○ Resiniferatoxin					
	○ NADA			<25°C	○ Menthol	TRPM8
	○ Anandamide				○ Icilin	
	○ Ethanol				○ Eucalyptol	
	○ Acidic pH		<17°C	○ Cinnamaldehyde	TRPA1	
>52°C	○ GF	TRPV2		○ Mustard oil		
>33°C	○ Camphor	TRPV3		○ Allicin		
	○ 2-APB			○ Icilin		

CHolinergic SYNAPSE

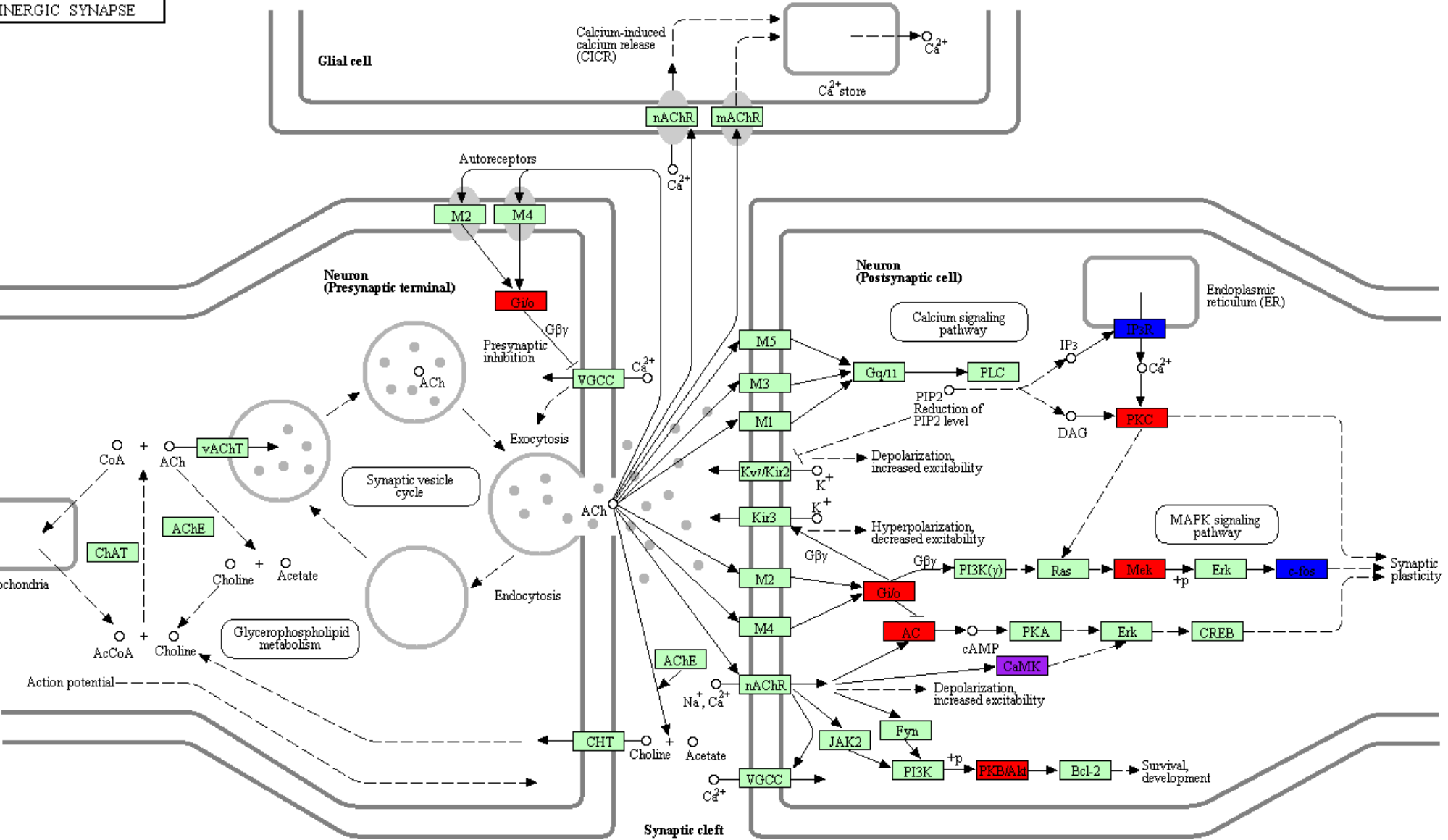

GAP JUNCTION

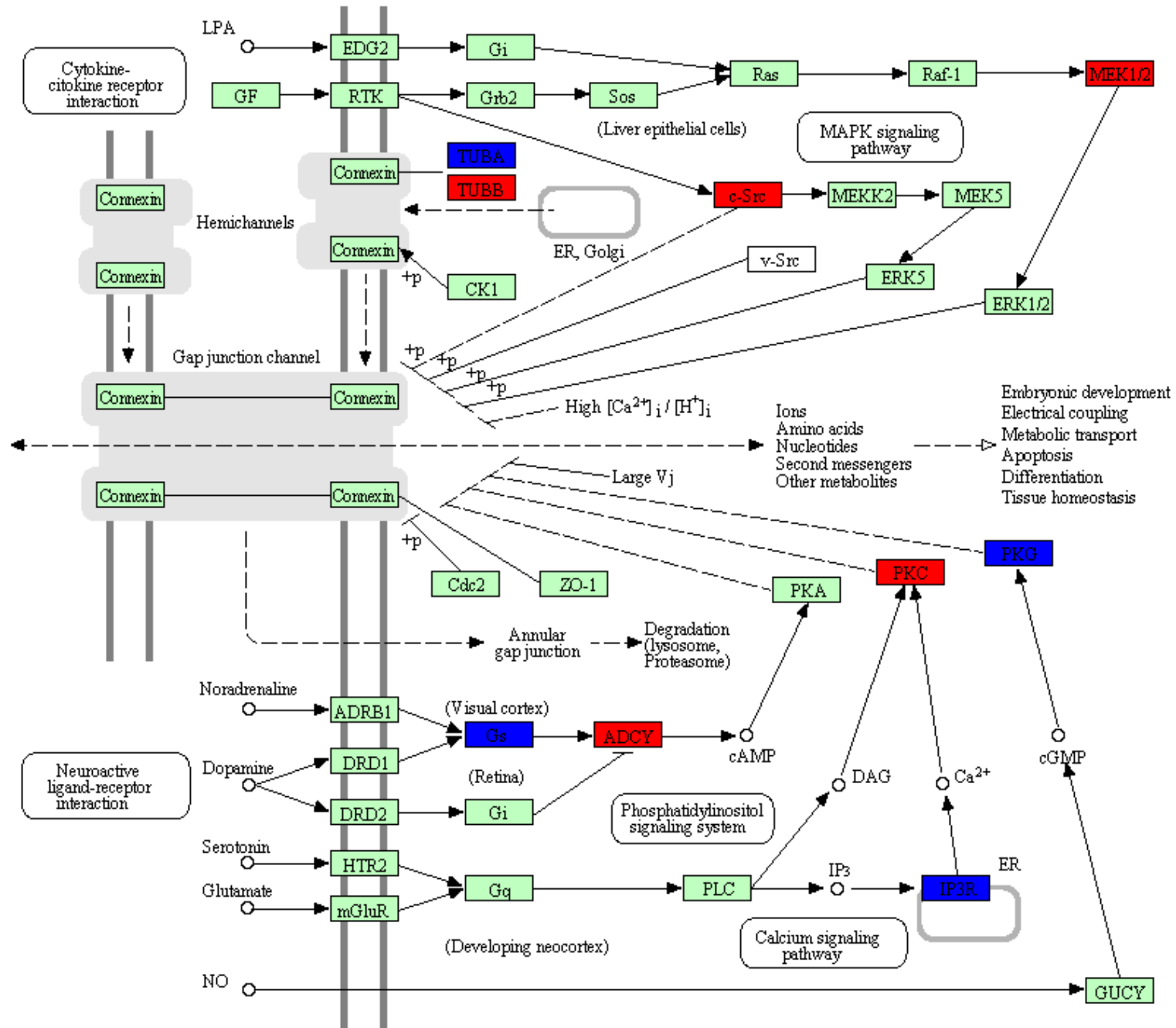

GnRH SIGNALING PATHWAY

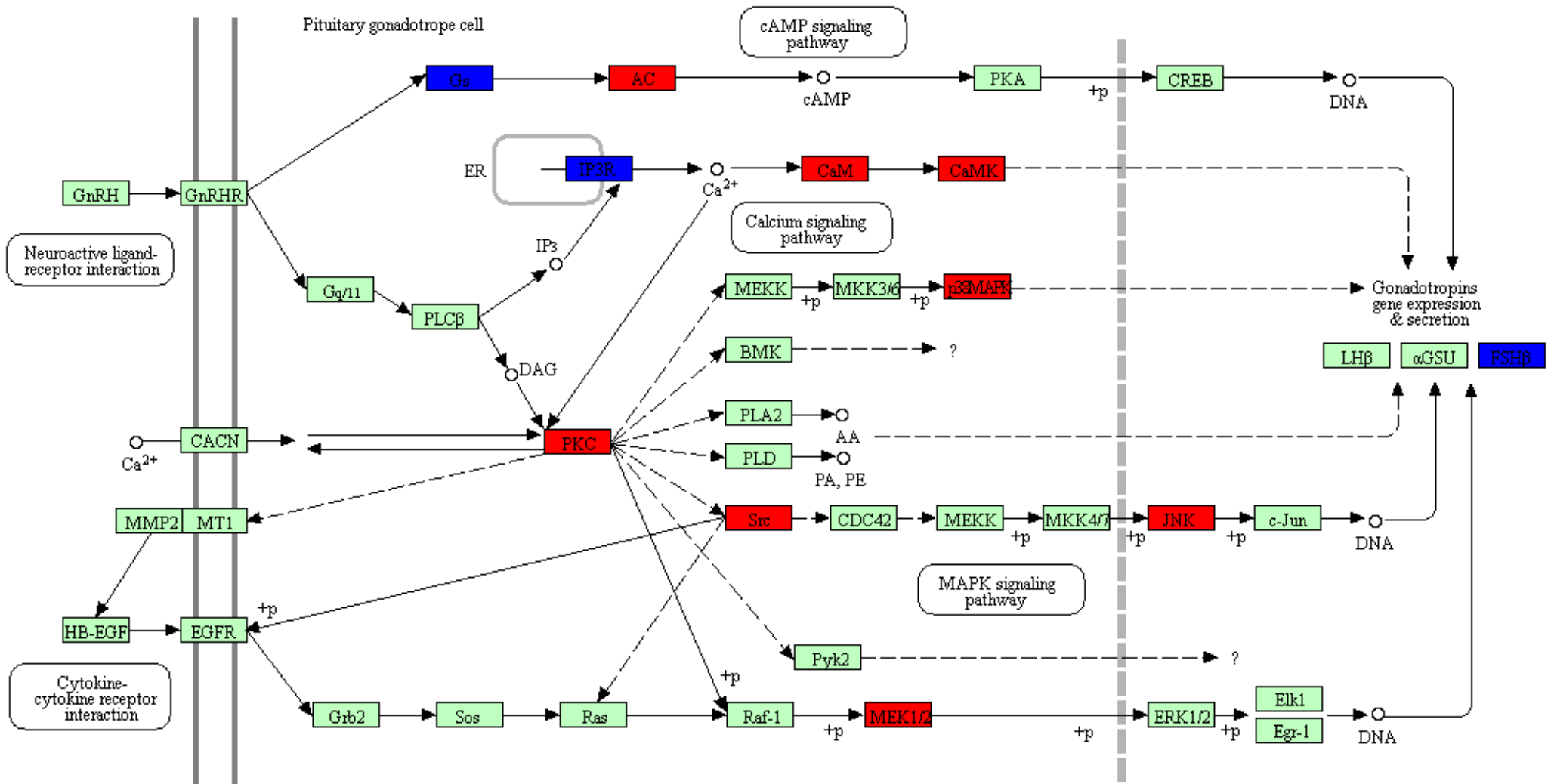

HIF-1 SIGNALING PATHWAY

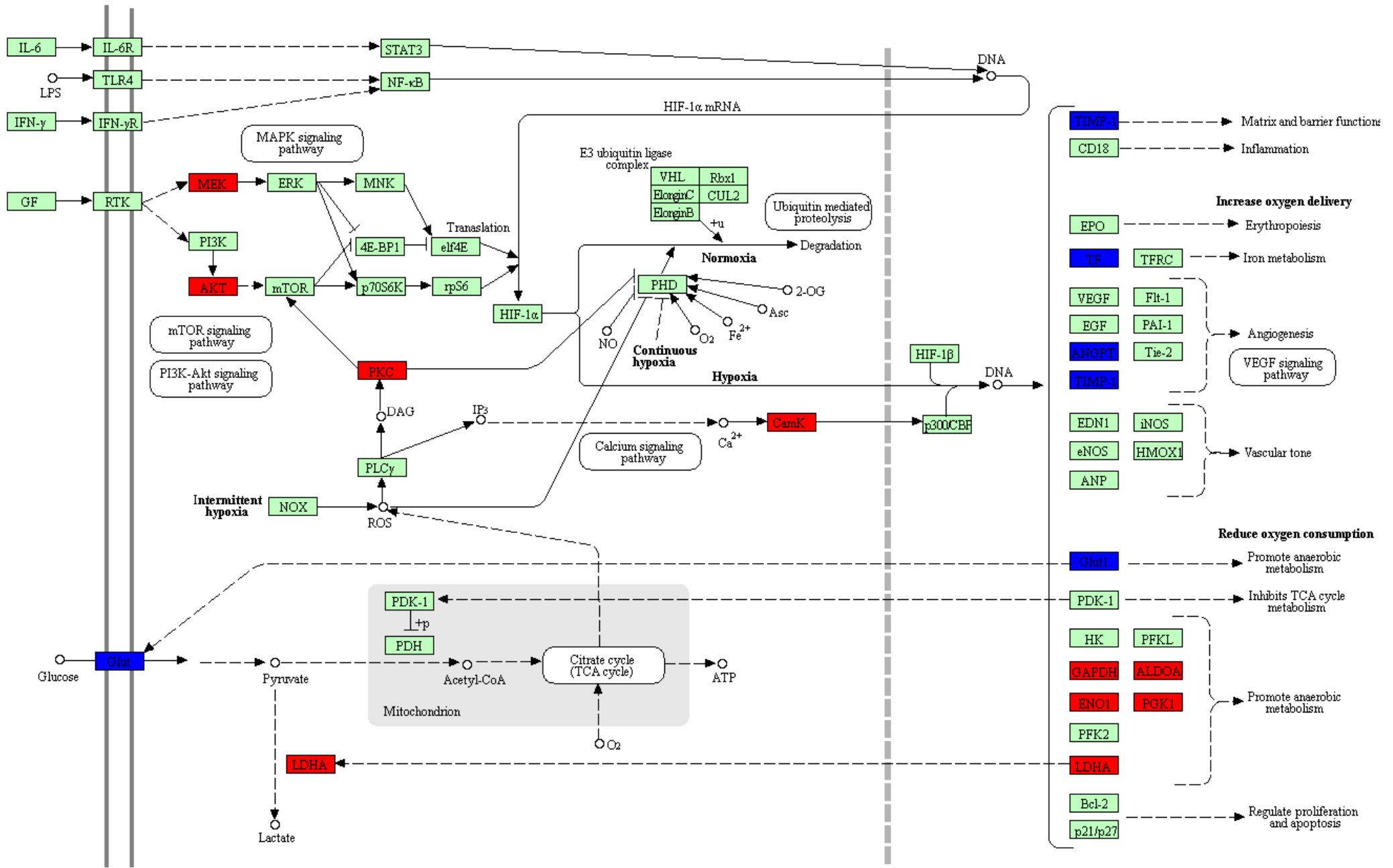

ARRHYTHMOGENIC RIGHT VENTRICULAR CARDIOMYOPATHY (ARVC)

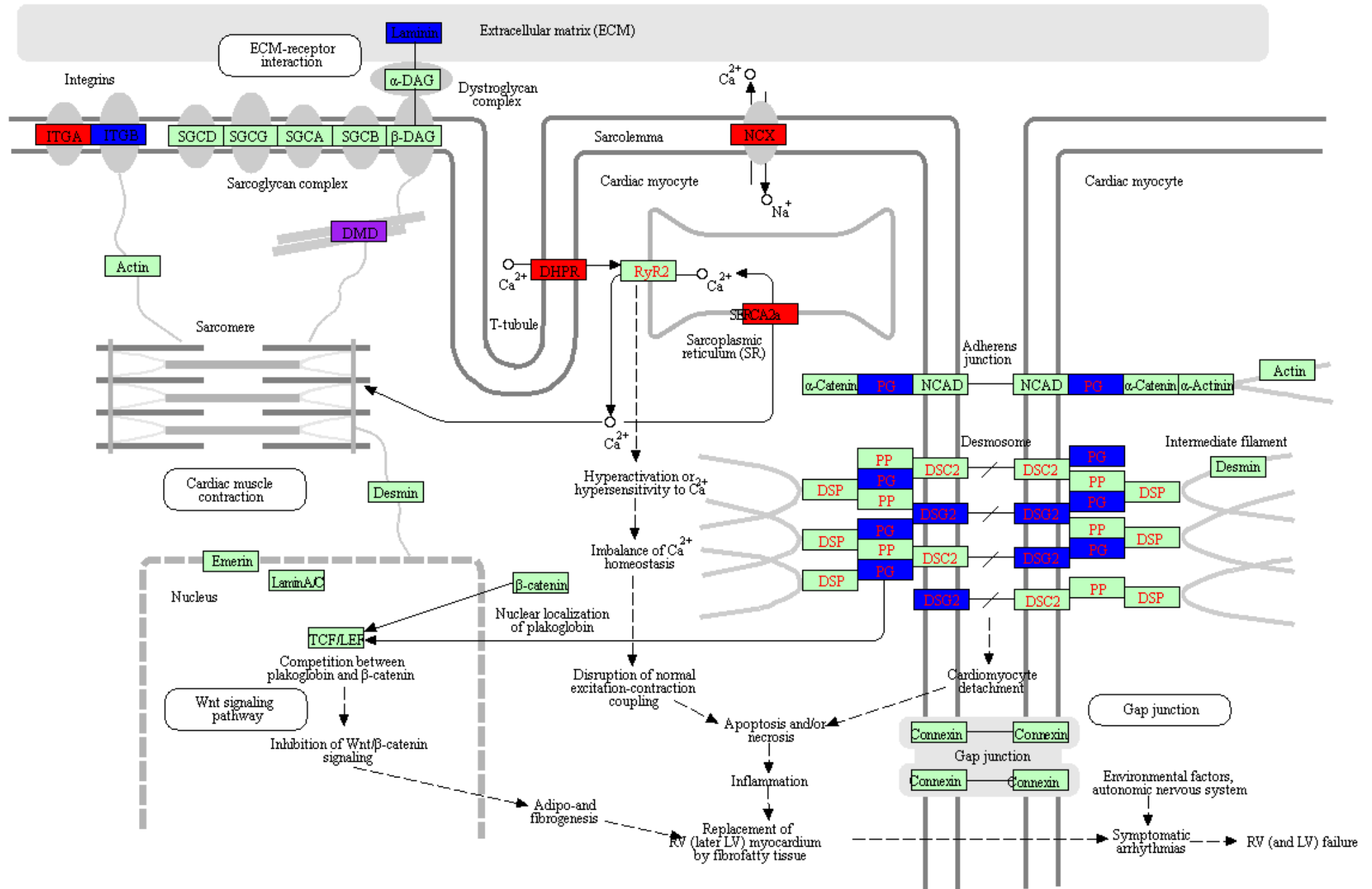

SMALL CELL LUNG CANCER

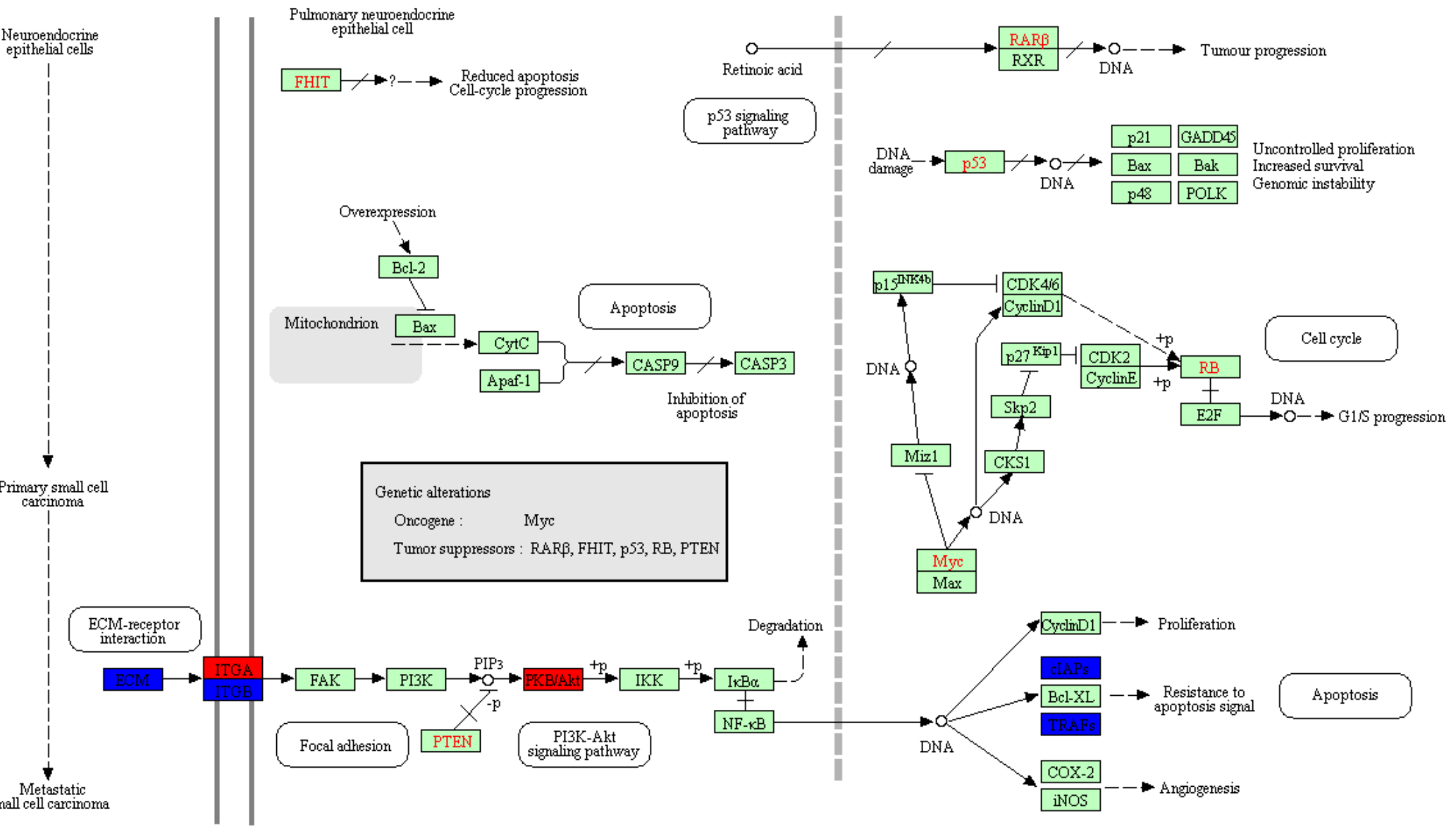

ADIPOCYTOKINE SIGNALING PATHWAY

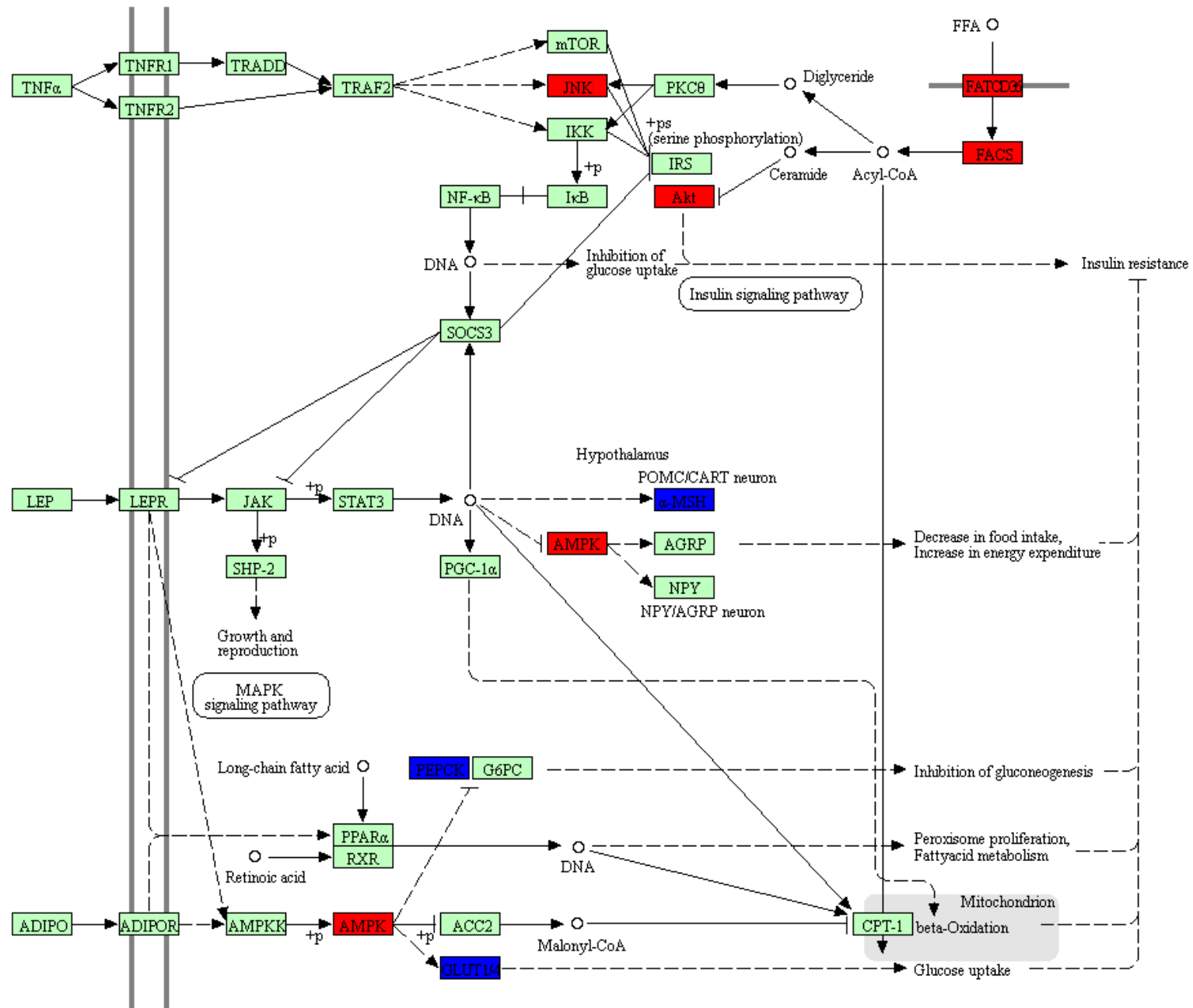

AMPHETAMINE ADDICTION

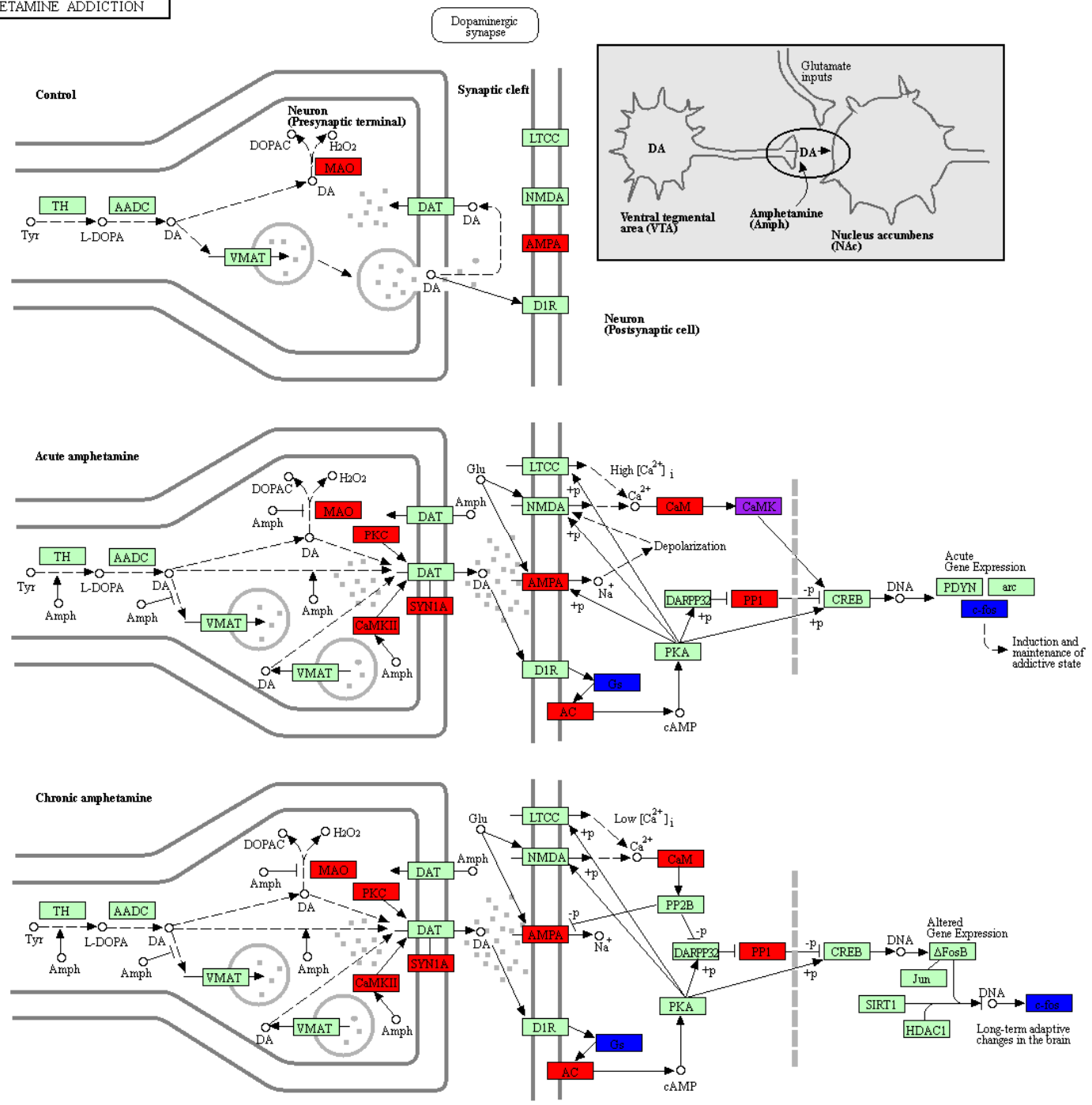

GLYCINE, SERINE AND THREONINE METABOLISM

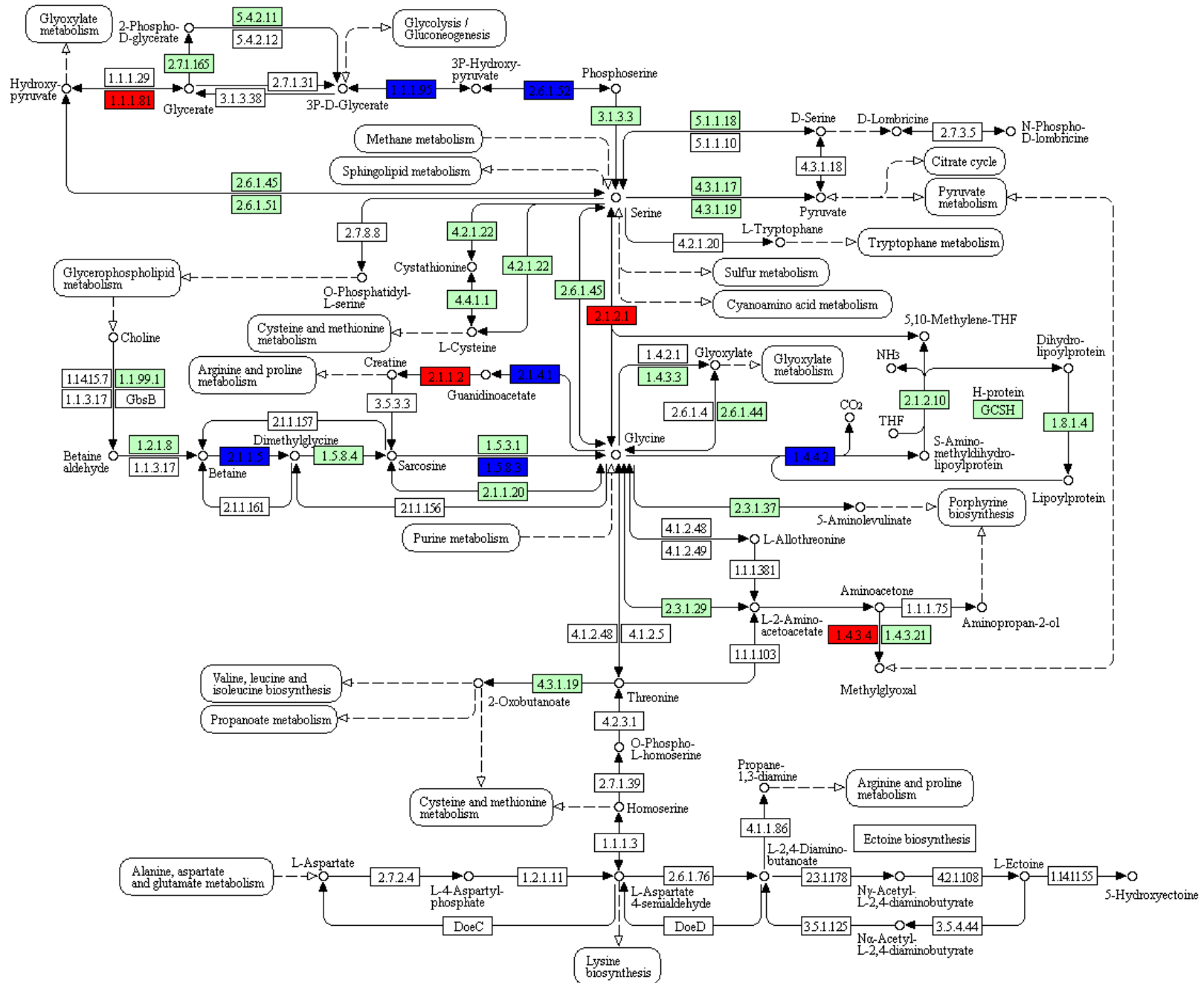

ARGININE AND PROLINE METABOLISM

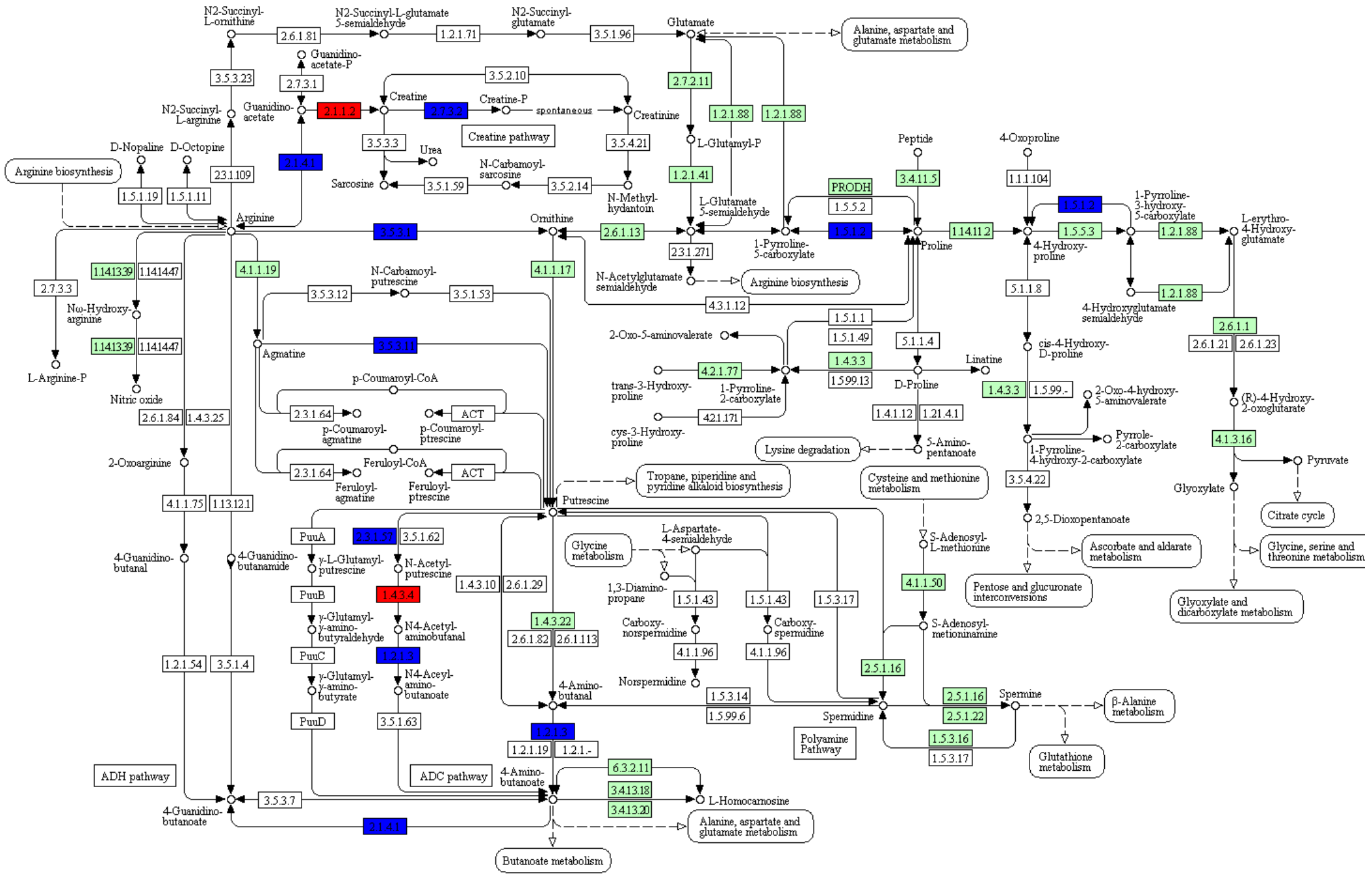

FERROPTOSIS

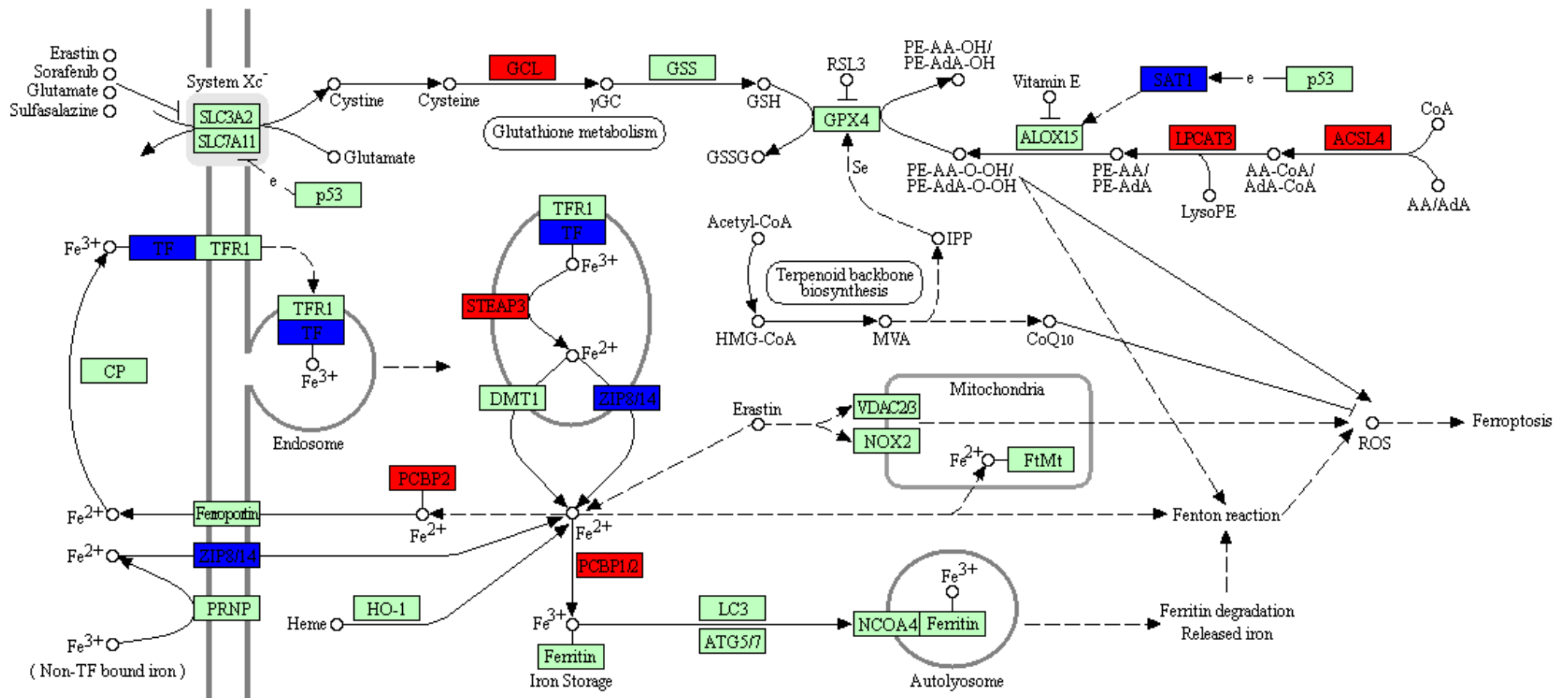

CYSTEINE AND METHIONINE METABOLISM

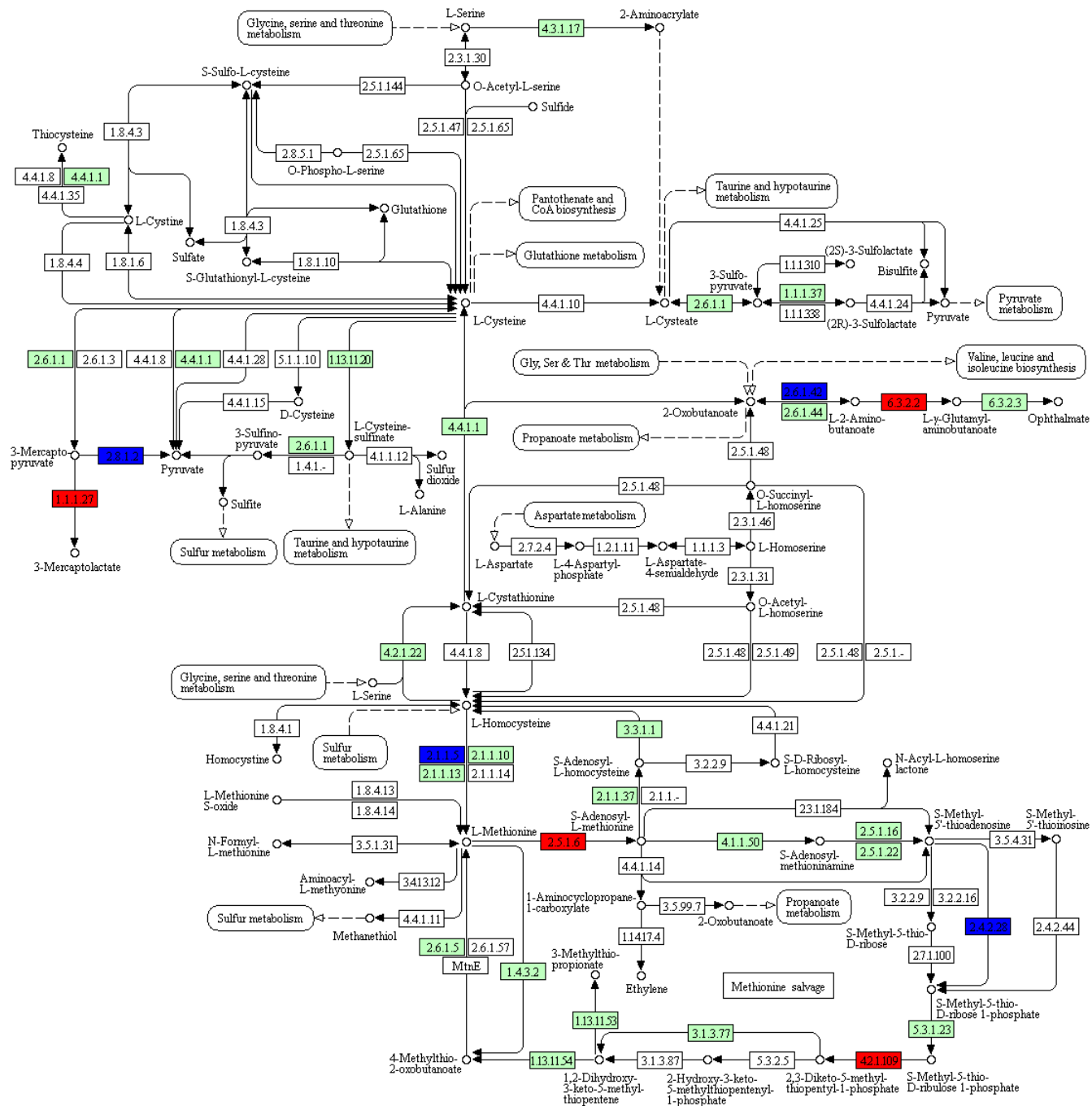

FATTY ACID DEGRADATION

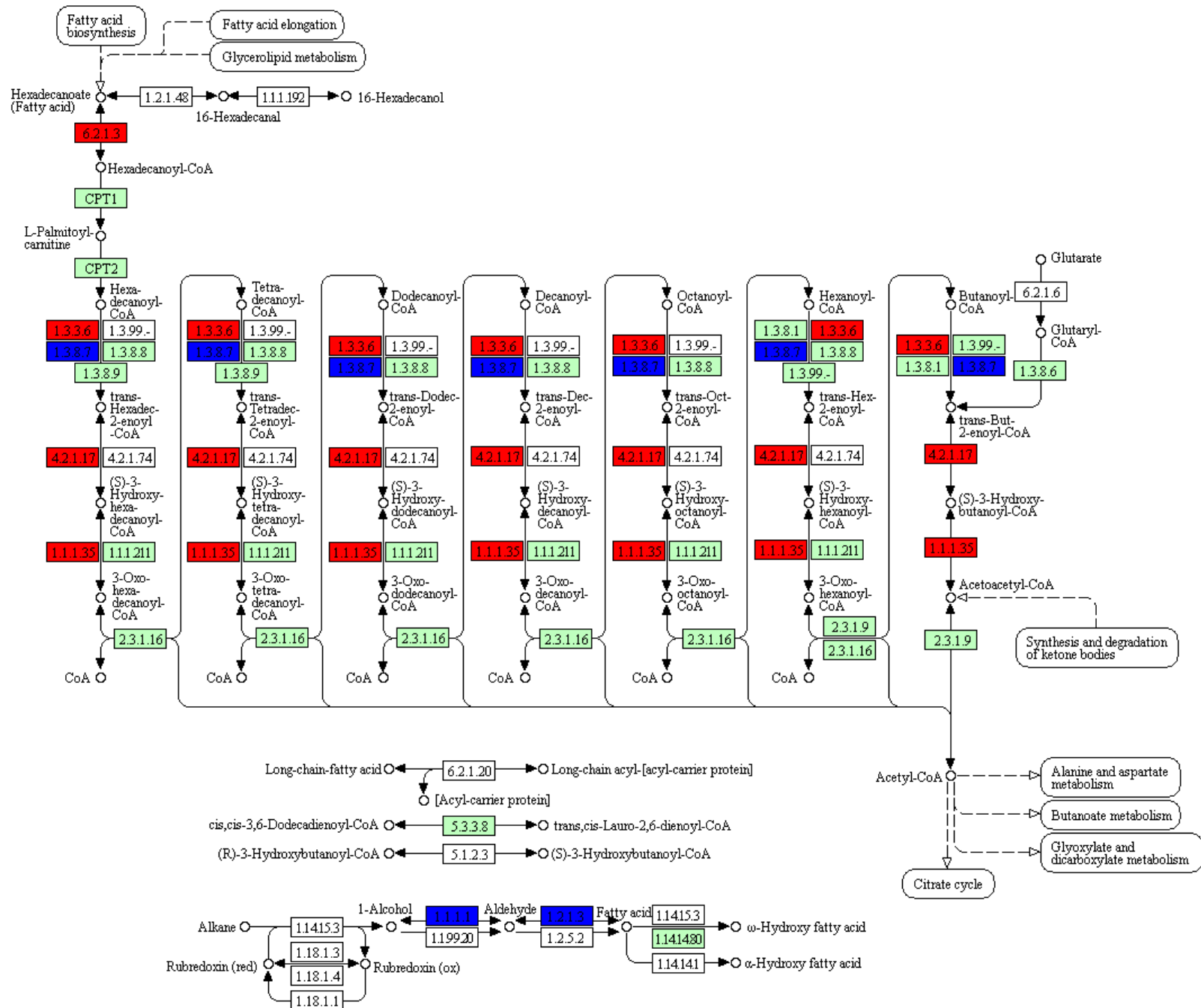

BIOSYNTHESIS OF UNSATURATED FATTY ACIDS

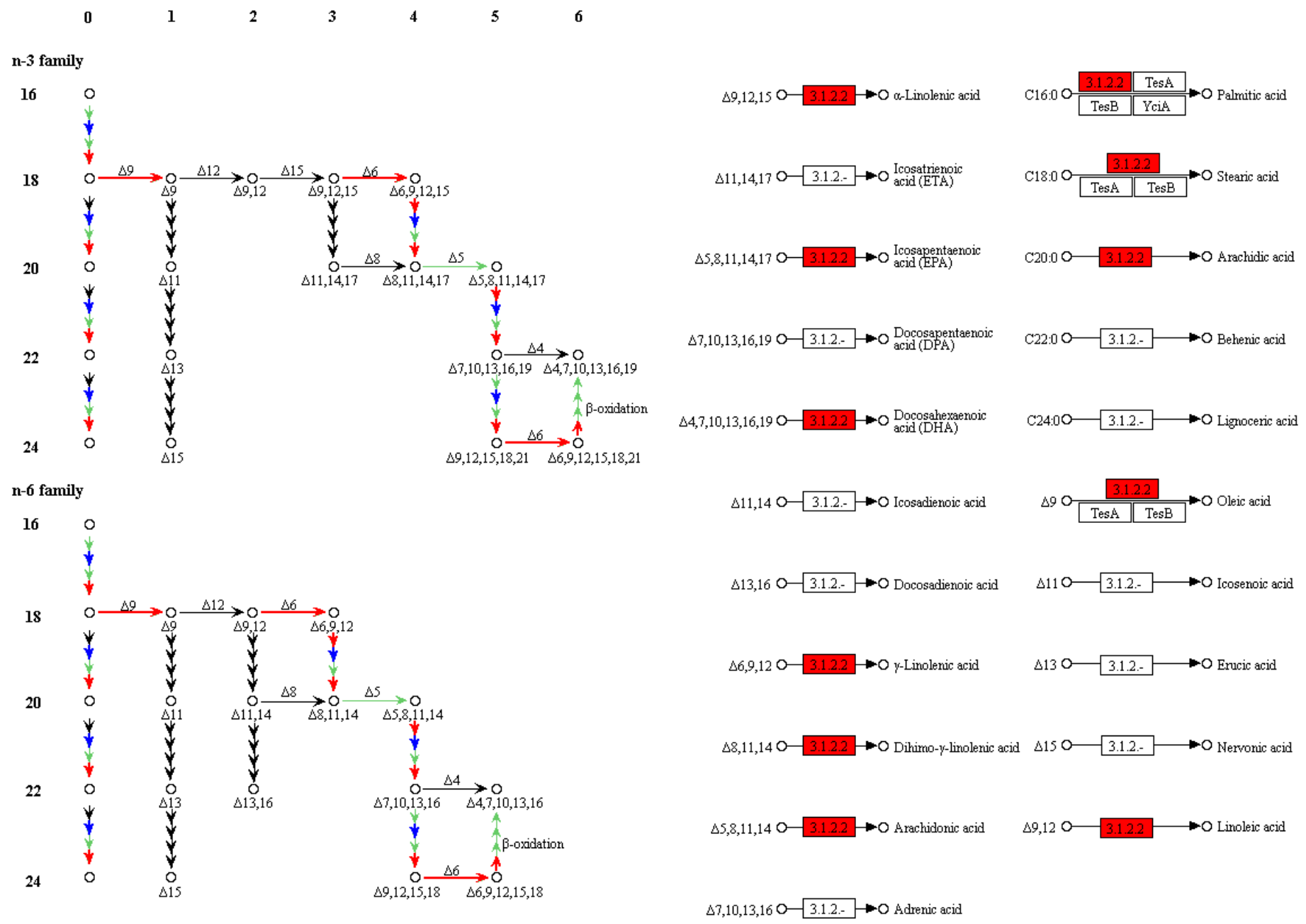

CITRATE CYCLE (TCA CYCLE)

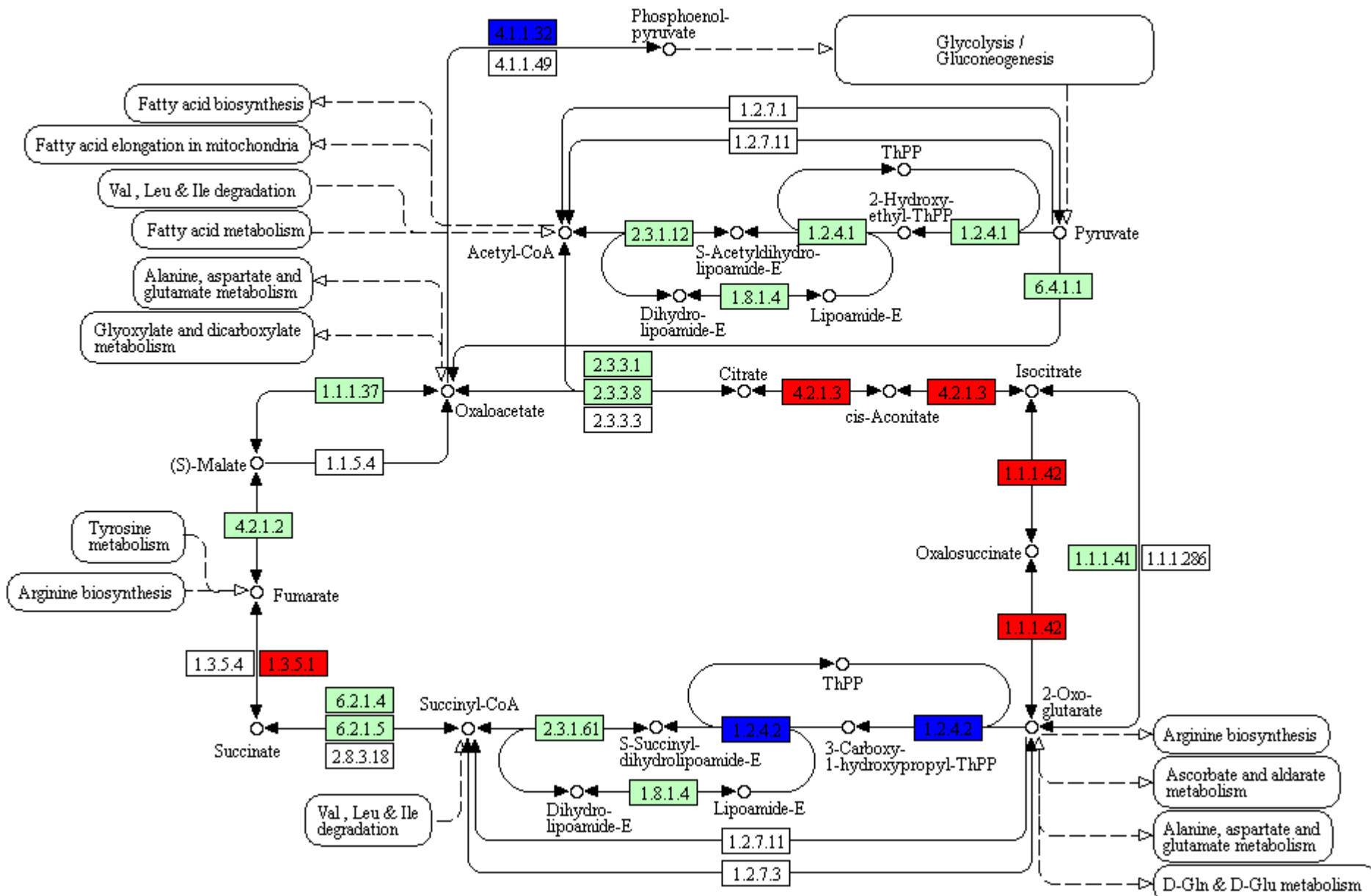

GLYOXYLATE AND DICARBOXYLATE METABOLISM

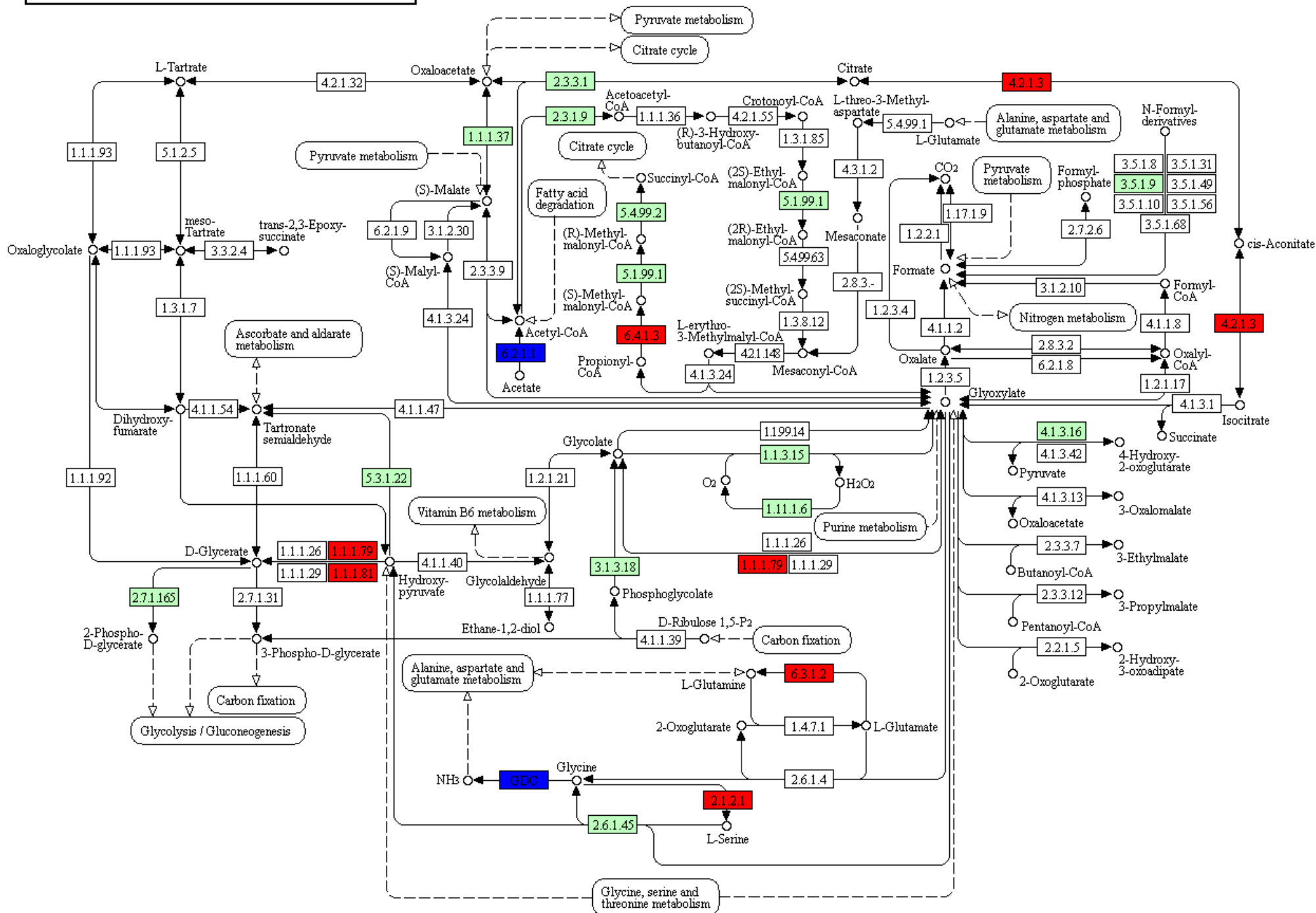

MUCIN TYPE O-GLYCAN BIOSYNTHESIS

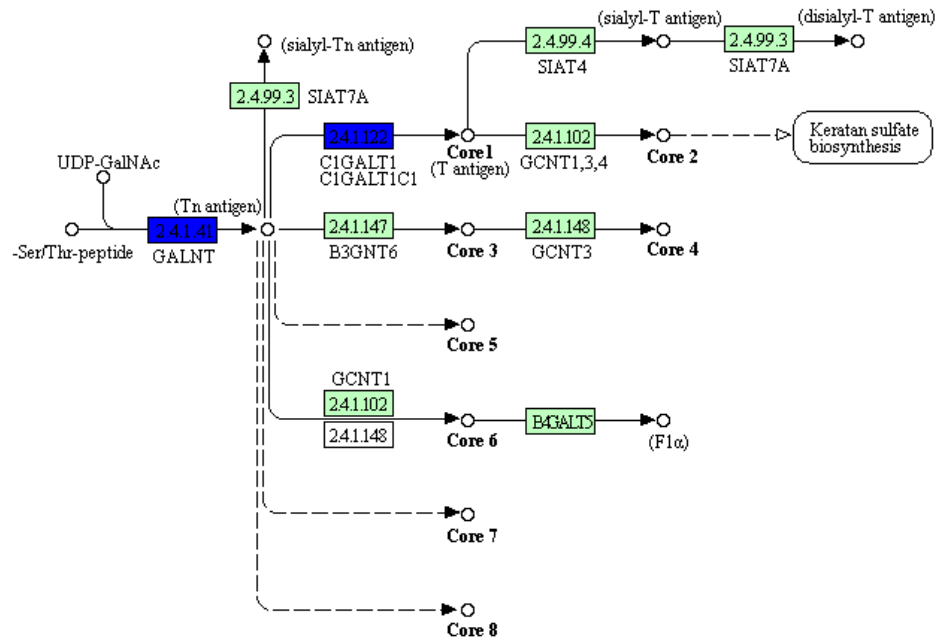

Tn antigen

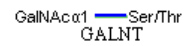

Sialyl-Tn antigen



Disialyl-T antigen

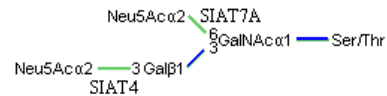

Core 1, 2

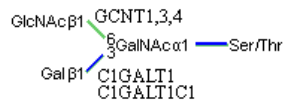

Core 3, 4

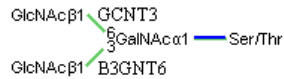

Core 5



Core 6 & F1 α



Core 7



Core 8



PROPANOATE METABOLISM

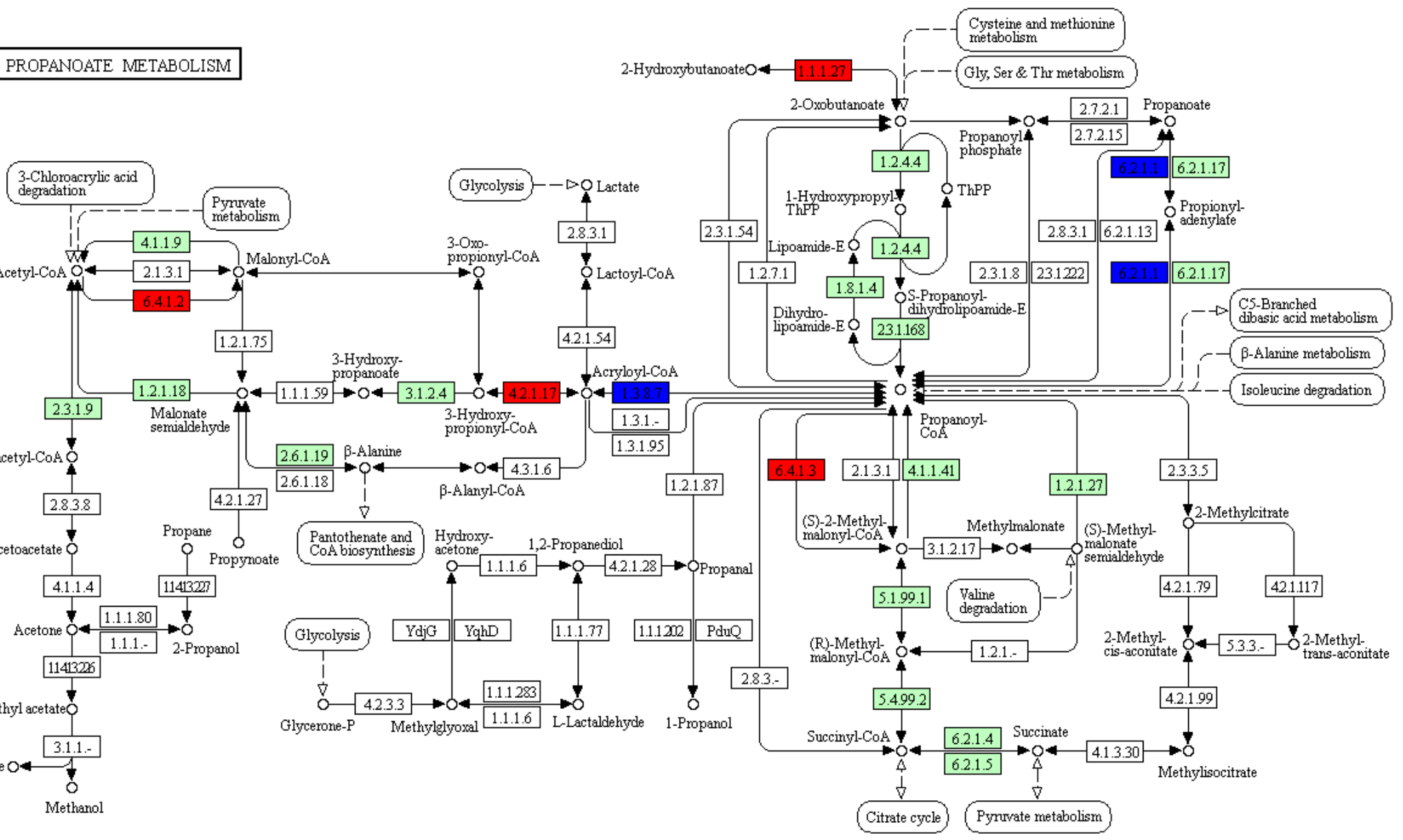

PROXIMAL TUBULE BICARBONATE RECLAMATION

