

Electronic Supporting Information

John H. Day^{1,*}, Tristan M. Nicholson^{1,2,*}, Xiaojing Su¹, Tammi L. van Neel¹, Ivor Clinton¹, Anbarasi Kothandapani³, Jinwoo Lee^{3,4}, Max H. Greenberg⁵, John K. Amory⁶, Thomas J. Walsh², Charles H. Muller^{2,7}, Omar E. Franco⁵, Colin R. Jefcoate⁴, Susan E. Crawford⁵, Joan S. Jorgensen³, Ashleigh B. Theberge^{1,2,**}

¹Department of Chemistry, University of Washington, Box 351700, Seattle, WA 98195, United States

²Department of Urology, University of Washington School of Medicine, Seattle, WA 98195, United States

³Department of Comparative Biosciences, University of Wisconsin-Madison, Madison, WI 53706, United States

⁴Department of Cell and Regenerative Biology, University of Wisconsin-Madison, Madison, WI 53706, United States

⁵Department of Surgery, NorthShore University Research Institute, Affiliate of University of Chicago Pritzker School of Medicine, Evanston, IL 60201, United States

⁶Department of Medicine, University of Washington, Seattle, WA 98195, United States

⁷Male Fertility Laboratory, Department of Urology, University of Washington School of Medicine, Seattle, WA 98195, United States

*These authors contributed equally to this work.

**Email address for correspondence: Ashleigh B. Theberge, abt1@uw.edu

Table of Contents

Figure S1: Diffusion of fluorescent dyes through collagen and agarose gel walls

Figure S2: Representative images of high-resolution imaging workflow

Figure S3: Representative image of sub-optimal device layout in 12-well plate

Figure S4: Monorail1 evaporation data

Figure S5: High resolution immunostaining comparison

Figure S6: smFISH comparison

Figure S7: Preliminary triculture experiment images

Figure S8: Monorail1 technical drawing

Figure S9: Monorail2 technical drawing

High resolution TIFF images (All)

CAD files

Protocols

Hydrogel loading video

Materials and methods

Diffusion experiments (Figure S1):

Device preparation Injection molded Monorail2 devices were sonicated in isopropanol for 1 h, soaked in 70% ethanol for 30 min, and allowed to air-dry overnight. Before use, devices were plasma treated for 5 min at 0.25 mbar and 70 W in a Zepto LC PC Plasma Treater (Diener Electronic GmbH, Ebhausen, Germany) using oxygen. The devices were inserted into the bottom of a tissue culture treated polystyrene 12-well plate (Corning, 07-200-82) and loaded with 40 μ L of either collagen or low gelling temperature agarose. Once gelled, 1X PBS was loaded into the center chamber (8 μ L), side chambers (20 μ L/chamber), and sacrificial media reservoir (500 μ L) and stored at 6 °C overnight. 1X PBS in the center chamber was replaced with fluorescent dye the following morning (t = 0 hour), and the plate was incubated at 37 °C. Solution from the side chambers were collected and pooled at t = 6 h, 12 h, and 24 h for each technical replicate. The fluorescence of each sample was measured using a Multiskan Spectrum UV/Visible Microplate Reader (Thermo Labsystems, Waltham, MA) (n = 4 for each time point).

Fluorescent dye preparation 10 μ M fluorescent dye solutions for Alexa Fluor 488 (MW 546 Da, Thermo Fisher, A33077), dextran Alexa Fluor 527 (MW 10 kDa, Invitrogen, D22911) and dextran fluorescein (MW 70 kDa, Invitrogen, D1823) were all prepared in 1X PBS.

Evaporation experiment (Figure S4):

Device preparation Monorail1 devices were plasma treated in bulk as described above. Devices were then UV sterilized for 30 min and loaded into well plates. 35 μ L of type I collagen were loaded into the loading slot of each device, followed by 22 μ L of DMEM (10% FBS, 1% penicillin/streptomycin) into each culture chamber of each device. Devices were then incubated in a water-jacketed incubator at 37 °C for 24 hours. Control devices (experiencing no evaporation) were loaded with media after the incubation period.

Height measurement Liquid surface height measurements were performed using a C112JE Digitmatic Indicator (Mitutoyo, Aurora, IL) using the setup shown in Figure S4. For each device, all three culture chambers were measured three times each for a total of nine measurements per device. The three data for each chamber were then averaged and used to determine the average of the three culture chambers for each device.

Height-to-volume conversion Solidworks was used to simulate the shape of media interfaces in Monorail1 culture chambers; this was used to convert height data to change-in-volume data. The Monorail1 Solidworks file in the SI contains the (suppressed) features that were used for this conversion. Briefly, an extrude was used to fill the culture chambers with material. A lofted cut was then made from the upper rim (start) of each culture chamber to a point (end) along the central vertical axis of the chamber (some distance below the level of the upper rim) with an end tangent length of 1.5. This end tangent length was chosen because it created the greatest uniformity in curvature on the simulated interface (by eye, using the “Curvature” function under the Evaluate tab), which best approximated the real, uniformly curved interface. The height of the loft end point was then made to match the measured heights. To ascertain the change in volume, the volume of the entire device (including the device and the simulated media) was recorded from the “Mass Properties” function (under the Evaluate tab). The volume of each device was then subtracted from the average volume of all control devices.

Cell culture and staining (Figure S5):

Cell culture H259A cells were generously donated by the laboratory of G. D. Hammer (University of Michigan, Ann Arbor, MI). H295A cells were cultured in DMEM/F12 (Gibco, catalog No. 11330-032) containing 2.5% Nu-Serum TM I Culture Supplement (Corning, catalog No. 355100) and ITS+Premix Universal Culture Supplement (Corning, catalog No. 354352). Cells were cultured for 48 hours prior to staining and imaging.

Cell staining H259A cells were fixed and stained for actin and nuclei as in Figure 6. For 3 β HSD II staining, cells were incubated overnight at 4 °C in a 1:200 dilution of HSD3B2 primary antibody (Trans Genic Inc., Code No. KG619). The following day, cells were washed and incubated for one hour at room temperature with a secondary goat anti-mouse antibody conjugated to an Alexa Fluor 647 dye (Jackson ImmunoResearch, Cat# 115-605-146, 1:200 dilution).

527 Da fluorophore diffusion through collagen

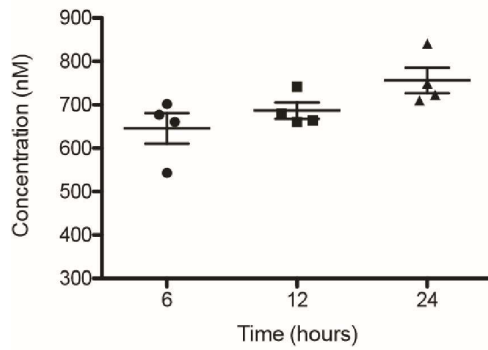

527 Da fluorophore diffusion through agarose

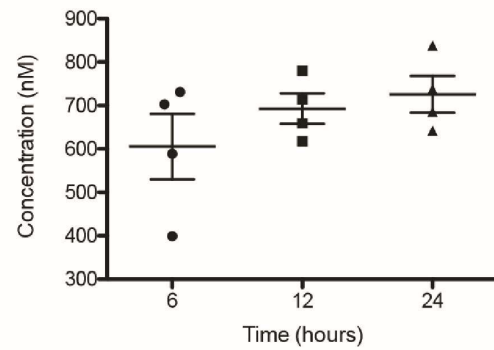

10 kDa fluorophore diffusion through collagen

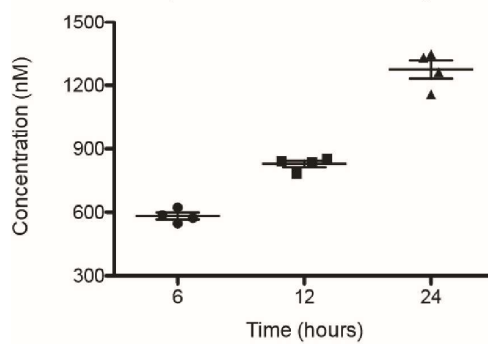

10 kDa fluorophore diffusion through agarose

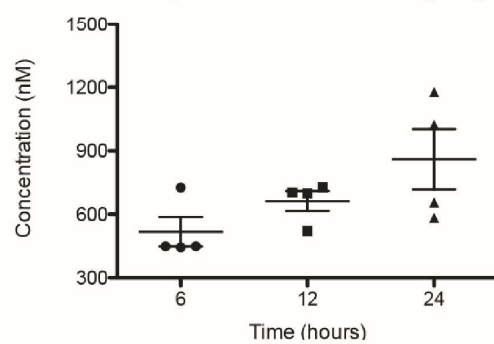

70 kDa fluorophore diffusion through collagen

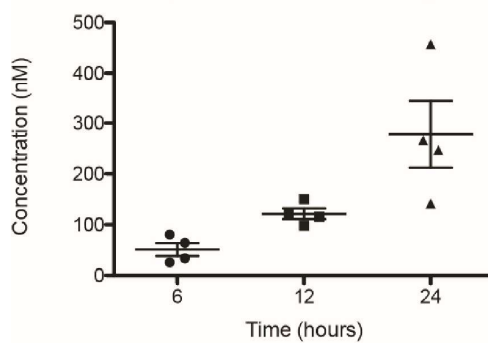

70 kDa fluorophore diffusion through agarose

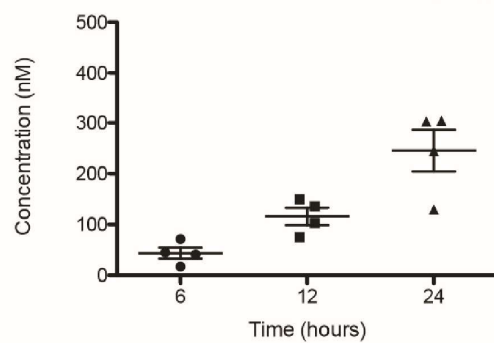
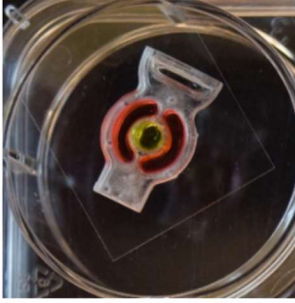
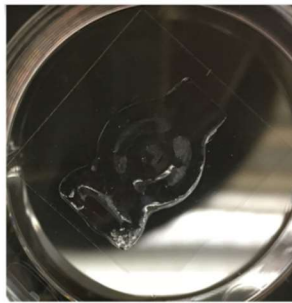

Figure S1: Diffusion of fluorescent dyes through collagen and agarose gel walls in Monorail2 devices. Concentrations of 527 Da (top row), 10 kDa (middle row), or 70 kDa (bottom row) fluorophore in receiving chambers of microculture device after 6, 12, and 24 hours. Gel walls through which diffusion occurred were made of either type I collagen (left column) or agarose (right column). Each plotted point represents a pooled sample from both outer chambers in a Monorail2 device. Error bars represent standard deviation.

Culture on coverslip



Remove device



Mount coverslip on slide

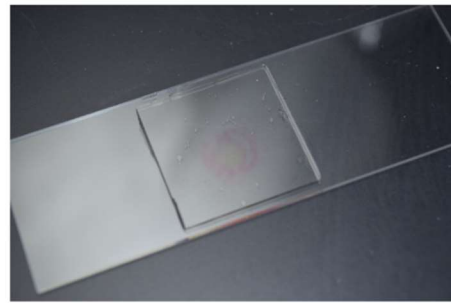
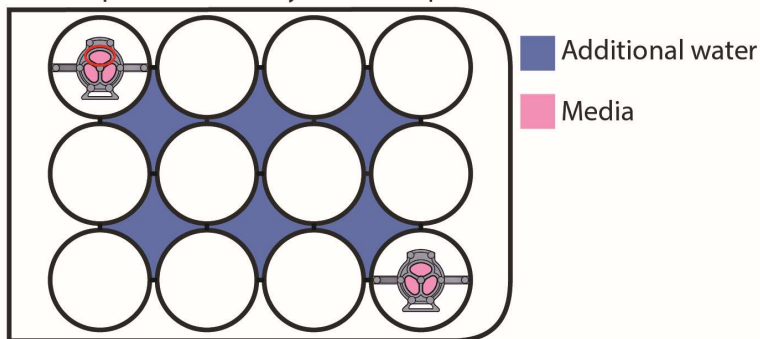

Figure S2: Representative photos of crucial steps in high-resolution microscopy sample preparation with CNC milled Monorail2 devices designed for use in a 6-well plate. Briefly, the device is placed on a coverslip in a 6-well plate (left), and a coculture experiment is carried out (here, food dye was added to cell culture chambers for visualization). The device is then removed, leaving a faint hydrogel residue (middle). Finally, the coverslip is removed from the well with fine-tip tweezers, inverted, and placed on a glass slide (right).

a) Sub-optimal device layout for evaporation control



b) Live/dead image

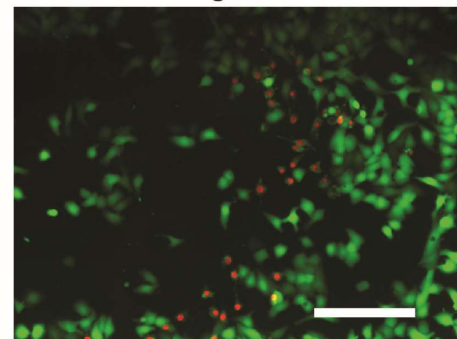

Figure S3: Cell viability in sub-optimal conditions for evaporation control. a) Well plate layout that leads to evaporation in cell culture chambers of monorail devices. b) Representative image of cell viability in top culture chamber of upper left monorail device from well plate layout (scale bar = 200 μm).

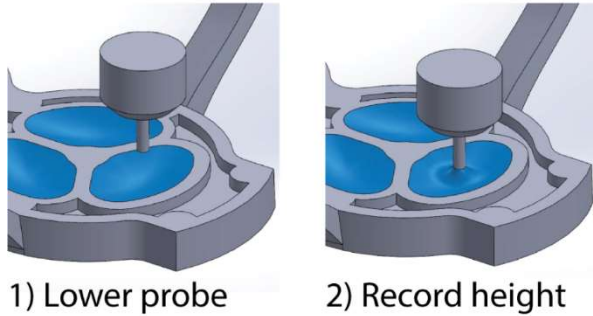
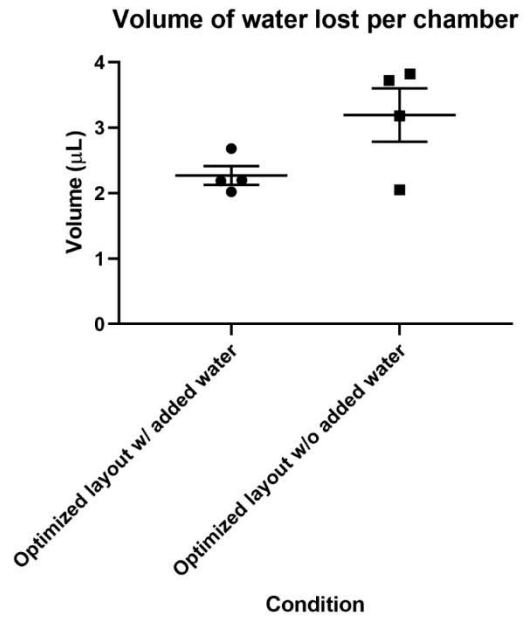
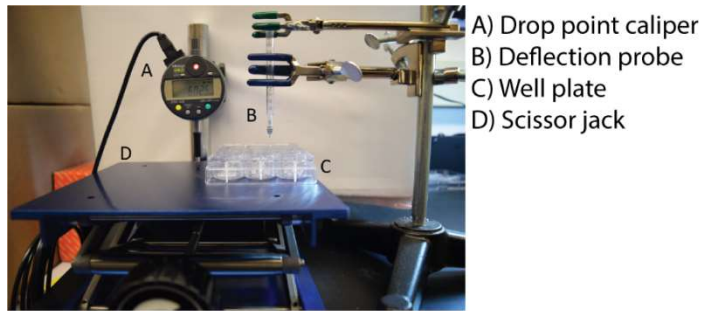
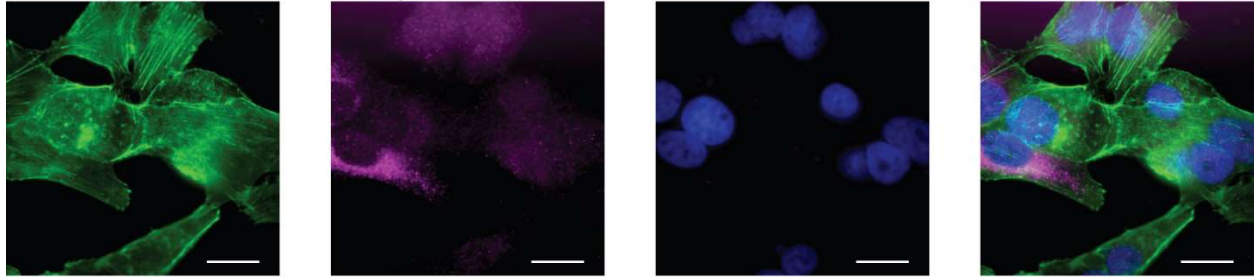

Figure S4: Monorail1 evaporation data. The top left panel shows a photo of the setup used to measure evaporation. Schematic drawings below the photo show the function of the deflection probe: the well plate is placed under the probe such that the probe tip is directly over the center of a culture chamber. The scissor jack is then raised slowly until the probe tip meets the liquid surface, at which point it causes a visible deflection at the air liquid interface. The height of the scissor jack is then recorded from the drop point caliper. The graph on the right shows the change in volume per culture chamber of Monorail1 devices in two conditions. Each data point represents a single device, where the heights of the three culture chambers were averaged, and the final average was used in the height-to-volume conversion as described in the Methods and Materials section above. Data are plotted with mean and SEM.

B) 63x images of H259A cells cultured on glass coverslips with Monorail1 device



A) 63x images of H259A cells cultured on glass coverslips without Monorail1 device

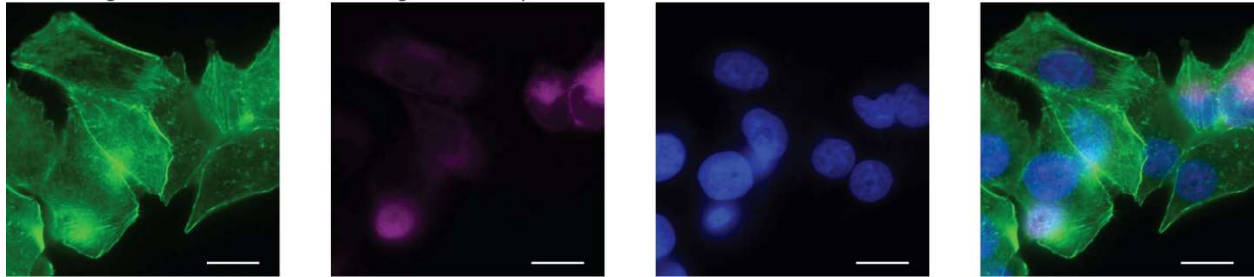
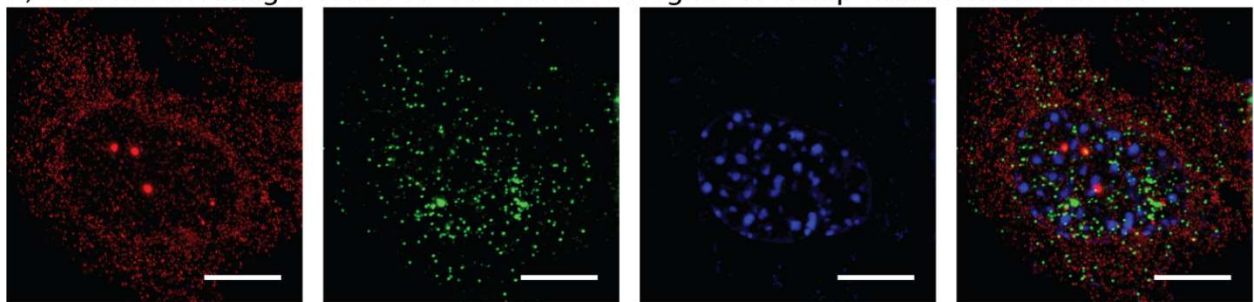

Figure S5: Imaging comparison of immunostained H259A cells cultured on glass coverslips A) in a Monorail1 device and B) in 12 well plate macroscale culture. Images show, from left to right: actin, 3 β HSD, and nuclei, and composite. Scale bars = 20 μ m.

A) 100x smFISH images of MA-10 cells cultured on glass coverslip with Monorail1 device



B) 100x smFISH images of MA-10 cells cultured on glass coverslip without Monorail1 device

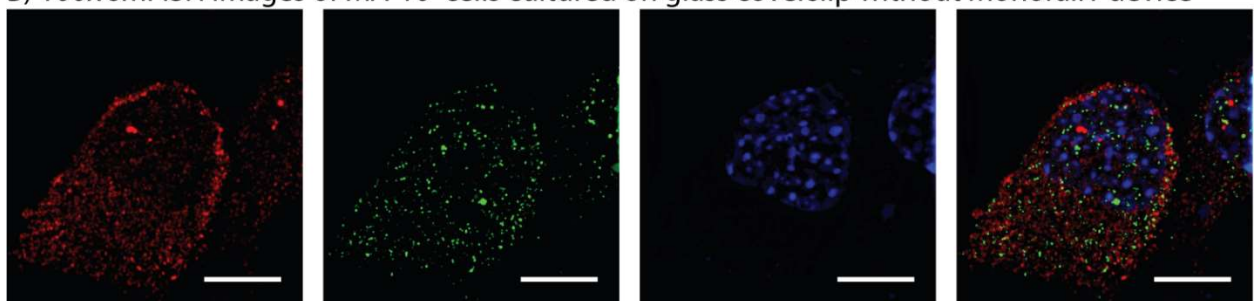
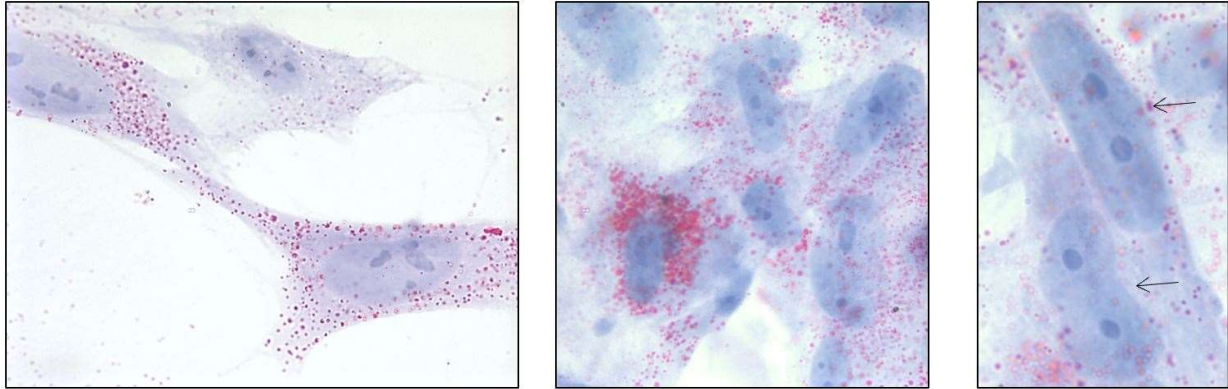

Figure S6: smFISH imaging comparison of MA-10 cells. Comparison between A) a 26-slice Z-stack image of an MA-10 cell cultured in Monorail (reproduced from Figure 6e) and B) a 24-slice Z-stack image of an MA-10 cell culture in 12 well plate macro-culture shows the same subcellular features and resolution. Images show smFISH probes designed to recognize spliced *Star* (red) and *Cyp11a1* (green), as well as DAPI (blue). Scale bars = 10 μ m.



CAFs Only

CAFs after Tri-culture – CAFs, PC-3, Adipocytes

Figure S7: Preliminary triculture experiment results. Comparison between triculture (center, right) and monoculture (left) conditions shows increased lipid droplet density (center) and increased binucleation (right) in triculture.

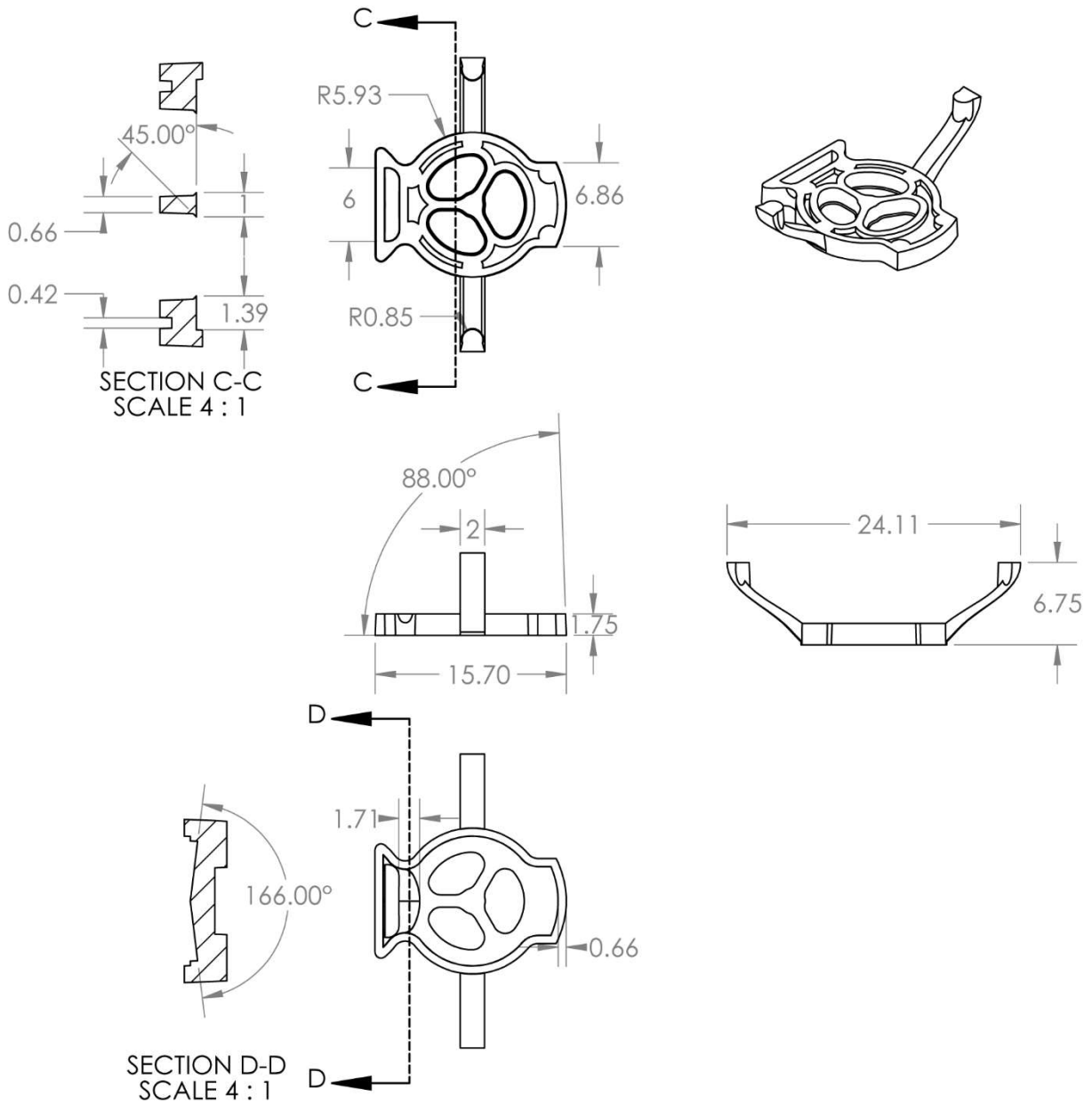
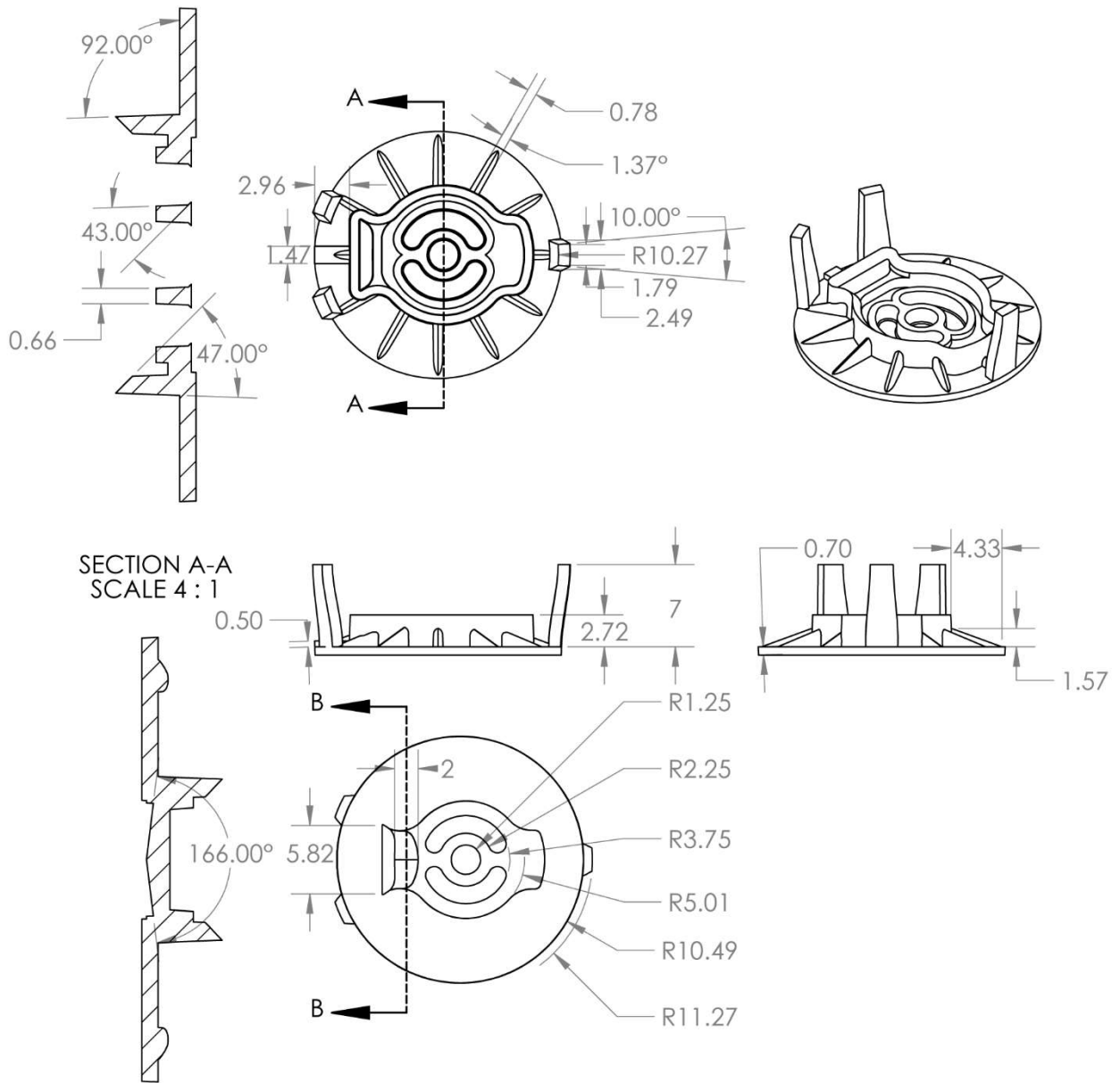

Figure S8: Monorail1 technical drawing. All vertical surfaces of both injection molded Monorail devices were angled by at least two degrees to allow for demolding, the last step of the injection molding process. Dimensions are in millimeters.



SECTION B-B
SCALE 4 : 1

Figure S9: Monorail2 technical drawing. Dimensions are in millimeters.