primers:

1F: 5'-TCTCTGAAGGAGTCGGTAAG -3'

1R: 5'-TAGTCCTGCTGATCCTGTCAA -3'

2R: 5'-TGCACATCTTACCATGCTGA -3'

5F: 5'-TGCTCATCTCTTCTGACAGGA -3'

3599R: 5'-TTGGGCCACTGTTAAGAAGTTC- 3'

3599R-XbaI: 5' **TGCTCTAGAT**TTGGGCCACTGTTAAGAAGTTC -3'

3987R: 5'-AAGAACGGATTCCTGGAGTCA -3'

3564F: 5'-TGGACATACCCAGGAACTTC- 3'

3438F: 5'- TGATCGCAGTGAGGATAGCTC -3'

518R: 5'-AACTTGGGTACCATAGGCACA -3'

159F: 5' -GAGCATATCCTTCATCTTTCTC- 3'

106F: 5'- TCATCTTTCTCTGGCTGGGAT- 3'

106F-ClaI: 5'-**CCATCGAT**TCATCTTTCTCTGGCTGGGAT- 3'

78F: 5' -TCCTGACGAGTGTTTTGAGCA- 3'

656R: 5'- CTCTCATTCTGCTCAATGTGC -3'

911F: 5'-AGCTGGAGTGATTGCAGAAG -3'

1661R: 5'-AGTTCAGTGGTGATGCTTGCA -3'

1425F: 5'-TCTGGAGTATGCAACCATGTTG -3'

2028F: 5'-GAACACCAGTGATCACAACAG -3'

2585F: 5'-AGGTGTTGAACTCTACACTGC -3'

2816F: 5'-ACCGGAGAGGGAATGGGC -3'

2990F: 5'-ACCAAACAGTTGTAGATAATGAG-3'

3009F: 5'-TGAGACTCTGGGTGAGCTGAA-3'

3035F: 5'-TGAACATCTCTGGAGCAGACA- 3'

ISO10-F: 5'-TGCAGCATTCTGCTCAACGT- 3'

ISO10-R: 5'-TGCTAGAAGCTTTCCTGGTCT -3'

ISOuni10-R: 5'-CAGATACCATCACGGTGGTTC- 3'

ISO8-F: 5'-ATGAACCACCGTGATGGTATC -3'

4394R: 5'-GAAGAACGGATTCCTGGACTC-3'

4369R: 5'-GATGTGCTAAAGGCTGCATTC-3'

4333R: 5'-TGGACCTGTCATGTCAGAAGC-3'

4298R: 5'-ACTCATGGCTGAGCAGAAGCA-3'

4263R: 5'-TGTACCTGGCATTTAGTGACC-3'

pE23E25-F: 5'-CTGCAGCATGTGATGGTATCT-3'

pE26E24-R: 5'-GTCTGCTAGAAGGGTGGTTCA-3'

3009F: 5'-TGAGACTCTGGGTGAGCTGAA-3'

2953F: 5'-GAAACCAACGGCCATCTCACAG-3'

3025F: 5'-CTGAACTCTGTGAACATCTCTGGA-3'

3426R: 5'-CTCTTCAAAAATGCTAGGGACACC-3'

3271R: 5'-AACAGCCGATGAGGACAAGCA-3'

The DNA sequence of camel isoforms

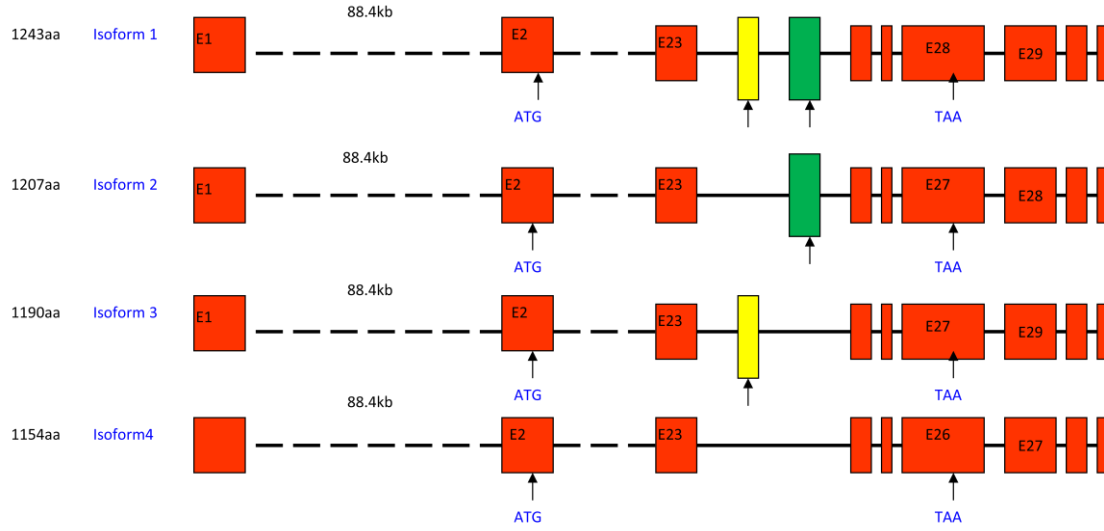

Isoform 1 cDNA sequence

ATTCTGCTCATCTCTTCTGACAGGAGCTTAACGCCGACTTAAATCAGATCTTTCTCTTGAAGGAGTCGG
 TAAGAAGCTCCTGACGAGTGTTTTGAGCATATCCTTCATCTTTCTCTGGCTGGG**ATGAGGGGGCTCAG**
GAGTCTAGTGTGGGCTCTGTTCGGCCTTCTTCCACCACCTTTGGTCTTTATTTCCCTCCTCACGT
GGAGCAGCTGCCACCATCACCGCTCAGACCTCAGGCACTATCATCGCCCTACCATATGATGAGCGAT
ACATATTC AAGTGTGAAGCCAAAGGAAACCAAGACCTACGTTCCGCTGGACAAAAGATGGGATG
GATTTTGACCCACATAAAGACCCTCAGGTCCTACAGAAAGAAAATACTGGAACCTTTGAGATACCA
AATAAAAAAGATAAAGTGAATACCAGGGAAAGTACAGATGTTACGCCTCCAACAAACTCGGAAC
TGCAACTTCAGAAGAAGCCGAATTTATTGTGCCTATGGTACCCAAGTTTCCAAGGAGAAGATAGA
GCCAATTGTGGTCACAGAGGGTGATTCCGGTGGTTTTGGAGTGTAACCCGCCACAAGGGATTCCACC
CTGGCAGCTGTACTGGATGACCAATGATCTCCGGCACATTGAGCAGAATGAGAGGGTGTCCATGGG
CCTCAGTGGGAATCTGTACTTCTAATACGCTGGTGTGACAGTCATGATGACTACTGCTGCTTCG
CCTCCTTTTCAAAAATACGCACAATCGTCCAGAAACCCCGCATGGTCTCAAGGTCAAGCCAGTTGA
TGCAAAGCAAGAGGATGGTGATGCCAAGATTGTTCCAGGAGAGGAAGCCAAGCATCTTGTTCCCT
CCAGTCATTCAACGACTTTCCTGAAAAAAGGAGAAGAGCTGGAGCTGGAGTGTATTGCAGAAGGA
CTGCCTACCCGGAGGTAGAATGGATCAAGATATGGGGTGACTTACCAAAGCGCACGCAGATAAAG
AACTTCGAAAGCTTCTGACAATACCAAACATCAGAGAAGAGGACGAAGGAAAATACATGTGTAA
AGCCAAGAATCAGCATGGTGAAGATGTGCATCATTTCCAGGTCGAAGTAGAGGAGCCACCGAGCT
GGCAGAAGGAGCCGCTGAAGAGTCAGTTAGCATGGATTGGATCTGACATCCACATCAACTGTTCTG
CTACCCGAAAACCGCAACCCACAATCACCTGGAAAAGAAACGGCAAGCCCCTCGATGATTTCCCTT
CCACCCATCACAAAATGCTTGACGACAGAATAATCATACTCAAAGCGGAGCAGAAAAGATACCGCTG
TGTACCAGTGTGAGGCCTCCAACAAACACGGCAGCCTACTGGCCAATGCTAATGTGCTAGTCATGAA
TCACCTCCTTTGATTCTGACGAGGAATTATCTGGAGTATGCAACCATGTTGGGCAAGAGTGTGATT
ATGGACTGCAATGTCTTTAGTTCACCACCTGCCACCCTAACTGGAGAAGAGAAGACCCAGAGGGC
TCTGTAGATGGAGAGAGATATTCTCTGCTGAAGAATGGCTCCCTGCAGATTCACAAAGTCGAGATG
GAAGATATGGGCCAGTACAAATGCTTGGCAAACAACTCCGAGGGCTCTGCAAGCATCACCCTGAA

CTTTTCATTAAAGATTCCACTAGGATCGTGGAGGCTCCTCAAGACATGAAGGTCATCCGGGGATCTG
TGGCCGAGCTGGAGTGCCAGGTGGAGTGGACCCGTCTCTGAGAAGAGAGCTGGAGTTCGTTTG
GCTCAAAGATGGGATAAATATCCTCTCGAACTCCTCAGAAAGGTATTTTACAGATGAAGGAATTCTT
CAGATATTCAACGTGAGTCACAGTGATCAAGGAATTACACCTGTATTGTTTGAACATCCCTGGACC
AAGATACAGCTTCTGCATACATAACAGTCTTAGATGTCCCCGATCCTCCGGTTGAATTATTGCTCAGT
GATCTGAAAGACCCGAGTGTGAAGTCCACTGGGTGAACACCAGTGATCACAACAGTCCATAACA
GAGTTCATCATCCAGTACGAAGAGAGCCACTGGGAGCCAGAGAAGTGGAAGATCTTCTTCGAGT
GTCTAGCAGGAAGTTCTCAGCCCCCTGGCTCTGTAAGTCCACATTAATACTACCAGTTCAGAGTCATCG
CTGTCAATGAAATAGGGAGAAGTCATCCAGTATGCCCTCAGGAAGATATAAAACACCTCCATGTGC
TCCTGACAGGAACCCAGAAAACATTAAGATTGAGGGTCACTGCCACATCAGATGGACATCAGCTG
GGAGCCGCTCTTGCCGGTGGAGCACAACGGTCCCGGTCTGGAATACAACTGAGCTACAGGCTCCT
GGGTGTCGAGGACAGTTGGAAGAGCAGATGGTAAAGAGACACTCTTTTGTGGTGCAGACACC
CCGACATTGTCCTTATGAAGTCAAATCCAGGCCTTCAACCGCCACGGCTGGGCACCAGGACCC
AAAGTGGTACTGTTTATTCTGGGAAGACTTGCCTTGGTGGTCCCGATAACGTATCTGCGGAG
GTGTTGAACTCTACTGCTGAAGGTGAGTGGTACCAGTGCCCCAACCCACCTGAGGGGCCAT
CTTGAGGATACACAGTGAATACTGGCAAACCTCAGAGTCTGTTGACCTTAAGAAAATTCCCTCA
GAGAGACAGTCTCTACCATCCCTGAAACAGGAGTACACCATGGTGCCAGGACTGAAACCATT
TCTGAATATAGTCTGACTGTCAACGTCTTAACCGGAGAGGAATGGGCCCAAGCAGCAGTCCCA
TCTCTTTCACAACTCCACAAGGGAGTTCCTGAACAACCTCATAACCTGAAAGCCACAACTTTCAGA
AAGACGCCATCACACTGGTGTGGGCGCCTCCGCACGAAACCAACGGCCATCTCACAGGATACCTTC
TGCAATACCAAACAGTTGTAGATAATGAGACTCTGGGTGAGTGAACCTGTGAACATCTCTGGAG
CAGACACGACACAGTGGGTTTTGCGTGATCTGCAGGAAGACAACCTCATATAAGTTCTACTGAGTG
CGTGACGCAGGTGGGCTGTGGGTGAGCCATCAGTGAGAAAGGAGGCCACCGACCTGCAGCATTC
GTGCTCAACGTATCGACCTTGTAAAGAGACTTCTGCAAGAATCAGCTGGAGAACCAGAGGAGA
GCATTGAGATTCACAGCTCTATGTTGCTATAATGAACCACCGTGTGATGTTCTGGCAGCTTTCAGAG
CTTTAAATACATCTAAAGGTTTCCATCTGGTTGAAGGACTCAGCCCAGGAAGTGTGTACACAGTCCG
GCTGCAGGCTTACGCAGGGTTGGTGTCCCTAGCATTCTTGAAGAGGTTTCAAGACCAGGAAAG
CTTCTAGCAGACAAGAGATGGGATCTCAGGAGTGGTTTGTGGGGATGATGTGCGCGGTGGCTTTG
CTAACTCTGCTTGTCTCATCGGCTGTTTTGTGCTCAAGAACAAGGTGGCAAATACGCAGTAAAGG
AAAAGGAGAACATCCAGCTGATCCTGAATCTCATGGCATGGATGAAGAAACACCCTGTGAATACA
GTGACAATGATGAGAAGCCGCTGAAGAGCAGCCAGCAATTGTTCCGAGACGCCACAGAGGATGAT
CGCAGTGAGGATAGCTCTGAGATATCAGAGGATGATGACTGCGAGTTCAATGAAGATGGGTCATTC
ATTGGTGAATACTCTGGGTACATGCGCAGGACGTCCACGGCGGTCAACGGATTGAATGGACATACC
CCAGGAACTTCTTAAAGTGGCCCAATTTTATGAACCTTTTAAACAATTCAACAGTAAGAAAGTTTT
GTTTGAATGGTGTGCCATGAATGTGCCTATGCTTCTGCGTGATTGGGCCAGTTTTTCTACAGTATTAATA
TGAAGGTTGAAAATTTATGATTCTGCGCAACACAAAACAACCTGTTTCAAACCTTTGAGTTTTTTAAGC
AAAACCTTTTATGCTACTTTTTCCATTCAATTAATAAAAAA

Isoform 2 cDNA sequece

ATTCTGCTCATCTCTTCTGACAGGAGCTTAAACGCCGACTTAAATCAGATCTTTCTTGAAGGAGTCGG
TAAGAAGCTCCTGACGAGTGTGTTGAGCATATCCTTCATCTTCTCTGGCTGGGATGAGGGGGCTCAG
GAGTCTCAGTGTGGGCTCTGTGCGCCTTCTTCCACCACCTTTGGTCTTTATTTCCCTCCTCACGT
GGAGCAGCTGCCACCATCACCGCTCAGACCTCAGGCACTATCATCGCCCTACCATATGATGAGCGAT
ACATATTCAAGTGTGAAGCCAAAGGAAACCAAGACCTACGTTCCGCTGGACAAAAGATGGGATG

GATTTTGACCCACATAAAGACCCTCAGGTCACTACAGAAGAAAATACTGGAACCTTTGAGATACCA
AATAAAAAAGATAAAGTGAAATACCAGGGAAAGTACAGATGTTACGCCTCCAACAACTCGGAAC
TGCAACTTCAGAAGAAGCCGAATTTATTGTGCCTATGGTACCCAAGTTTCCAAGGAGAAGATAGA
GCCAATTGTGGTCACAGAGGGTGATTTCGGTGGTTTTGGAGTGTAACCCGCCACAAGGGATTCCACC
CTGGCAGCTGTACTGGATGACCAATGATCTCCGGCACATTGAGCAGAATGAGAGGGTGTCCATGGG
CCTCAGTGGGAATCTGTACTTCTAATACGCTGGTGTGACACAGTCATGACTACTGCTGCTCG
CCTCCTTCTTCAAATACGCACAATCGTCCAGAAACCCCGCATGGTCCTCAAGGTCAAGCCAGTTGA
TGCAAAGCAAGAGGATGGTGTGATGCCAAGATTGTTTCAGGAGAGGAAGCCAAGCATCTTGTTCCCT
CCAGTCATTCAACGACTTTCCTGAAAAAGGAGAAGAGCTGGAGCTGGAGTGTATTGCAGAAGGA
CTGCCTACACCGGAGGTAGAATGGATCAAGATATGGGGTGACTTACCAAAGCGCACGCAGATAAAG
AACTTCGAAAAGCTTCTGACAATACCAAACATCAGAGAAGAGGACGAAGGAAAATACATGTGTAA
AGCCAAGAATCAGCATGGTGAAGATGTGCATCATTCCAGGTGAAGTAGAGGAGCCACCGAGCT
GGCAGAAGGAGCCGCTGAAGAGTCAGTTAGCATGGATTGGATCTGACATCCACATCAACTGTTCTG
CTACCGGAAAACCGCAACCCACAATCACCTGGAAAAGAAACGGCAAGCCCCTCGATGATTTCCCTT
CCACCCATCACAAAATGCTTGACGACAGAATAATCATACTCAAAGCGGAGCAGAAAAGATACCGCTG
TGTACCAGTGTGAGGCCTCCAACAAACACGGCAGCCTACTGGCCAATGCTAATGTGCTAGTCATGAA
TCACCCCTCTTTGATTCTGACGAGGAATTATCTGGAGTATGCAACCATGTTGGGCAAGAGTGTGATT
ATGGACTGCAATGTCTTTAGTTCACCACCTGCCACCCTAACTGGAGAAGAGAAGACCCAGAGGGC
TCTGTAGATGGAGAGAGATATTCTGCTGAAGAATGGCTCCCTGCAGATTCACAAAGTCGAGATG
GAAGATATGGGCCAGTACAAATGCTTGGCAAACAACCTCCGAGGGCTCTGCAAGCATCACCCTGAA
CTTTTCATTAAAGATTCCACTAGGATCGTGGAGGCTCCTCAAGACATGAAGGTATCCGGGGATCTG
TGGCCGAGCTGGAGTGCCAGGTGGAGTGCACCCGTCTCTGAGAAGAGAGCTGGAGTTCGTTTG
GCTCAAAGATGGGATAAATATCCTCTCGAACTCCTCAGAAAGGTATTTTACAGATGAAGGAATCTT
CAGATATTCAACGTGAGTCACAGTGATCAAGGGAATTACACCTGTATTGTTTGAACATCCCTGGACC
AAGATACAGCTTCTGCATACATAACAGTCTTAGATGTCCCCGATCCTCCGGTTGAATTATTGCTCAGT
GATCTGAAAGACCGCAGTGTGAAGTCCACTGGGTGAACACCAGTGATCACAACAGTCCATAACA
GAGTTCATCATCCAGTACGAAGAGAGCCACTGGGAGCCAGAGAAGTGGAAGATCTTCTTCGAGT
GTCTAGCAGGAAGTTCTCAGCCCCCTGGCTGTACTGCCACATTAATACTACCAGTTCAGAGTCATCG
CTGTCAATGAAATAGGGAGAAGTCATCCCAGTATGCCCTCAGGAAGATATAAAACACCTCCATGTGC
TCCTGACAGGAACCCAGAAAACATTAAGATTGAGGGTCACTGCCACATCAGATGGACATCAGCTG
GGAGCCGCTCTTGCCGGTGGAGCACAACGGTCCCGGTCTGGAATACAACTGAGCTACAGGCTCCT
GGGTGTCGAGGACAGTTGGAAGAGCAGATGGTAAAGAGACACTCTTTTGTGGTGCAGACACC
CCGACATTGTCCTTATGAAGTCAAATCCAGGCCTTCAACCGCCACGGCTGGGACCCAGGACCC
AAAGTGGTGACTGGTTATTCTGGGAAGACTTGCCCTTGGTGGCTCCCGATAACGTATCTGCGGAG
GTGTTGAACTCTACTGCTGAAGGTGAGCTGGTACCAGTGCCCCAAACCACCTGAGGGGCCAT
CTTGGAGGATACACAGTGAATACTGGCAAACCTCAGAGTCTGTTGACCTTAAGAAAATTCCTCA
GAGAGACAGTCTCTACCATCCCTGAAACAGGAGTCACACCATGGTGCCAGGACTGAAACCATT
TCTGAATATAGTCTGACTGTCAACGTCTTAAACCGGAGAGGGAATGGGCCCAAGCAGCAGTCCCA
TCTCTTTCACAACTCCACAAGGGAGTTCCTGAACAACCTCATAACCTGAAAGCCACAACTTTCAGA
AAGACGCCATCACACTGGTGTGGGCGCCTCCGCACGAAACCAACGGCCATCTCACAGGATACCTT
TGCAATACCAAACAGTTGTAGATAATGAGACTCTGGGTGAGCTGAACTCTGTGAACATCTCTGGAG
CAGACACGACACAGTGGGTTTTGCGTGATCTGCAGGAAGACAACCTCATATAAGTTCTACCTGAGTG
CGTGACGCAGGTGGGCTGTGGGTGAGCCATCAGTGAGAAAGGAGGACCCGACCTGCAGCATGT
GATGGTATCTGGCAGCTTTCAGAGGCTTAAATACATCTAAAGGTTCCATCTGGTTGAAGGACTCA

GCCAGGAACTGTGTACACAGTCCGGCTGCAGGCTTACGCAGGGTTGGTGTCCCTAGCATTTTG
AAGAGGTTTCAAGACCAGGAAAAGCTTCTAGCAGACAAGAGATGGGATCTCAGGAGTGGTTTGTG
GGGATGATGTGCGCGGTGGCTTTGCTAACTCTGCTTGTCTCATCGGCTGTTTTGTGCTCAAGAACA
AAGGTGGCAAATACGCAGTAAAGGAAAAGGAGAACATTCCAGCTGATCCTGAATCTCATGGCATG
GATGAAGAAACACCCTGTGAATACAGTGACAATGATGAGAAGCCGCTGAAGAGCAGCCAGCAATT
GTTCCGAGACGCCACAGAGGATGATCGCAGTGAGGATAGCTCTGAGATATCAGAGGATGATGACTG
CGAGTTCAATGAAGATGGGTCATTATTGGTGAATACTCTGGGTACATGCGCAGGACGTCCACGGC
GGTCAACGGATTGAATGGACATACCCAGGAACTTCTTAA CAGTGGCCCAATTTTATGAACTTTTAA
ACAATTCAACAGTAAGAAAGGTTTTGTTGAATGGTGTGCCATGAATGTGCCTATGCTTCTGCGTGATT
GGGCCAGTTTTTCTACAGTATTAATATGAAGTTGAAAATTTATGATTCTGCGCAACACAA

Isoform 3 cDNA sequence

ATTCTGCTCATCTCTTCTGACAGGAGCTTAAACGCCGACTTAAATCAGATCTTTCTTGAAGGAGTCGG
TAAGAAGCTCCTGACGAGTGGTTTGAGCATATCCTTCATCTTTCTCTGGCTGGGATGAGGGGGCTCAG
GAGTCTCAGTGTGGGCTCTGTGCGCCTTCTTCCACCACCTTTGGTCTTTATTTCCCTCCTCACGT
GGAGCAGCTGCCACCATCACCGCTCAGACCTCAGGCACTATCATCGCCCTACCATATGATGAGCGAT
ACATATTCAAGTGTGAAGCAAAGGAAACCAAGACCTACGTTCCGCTGGACAAAAGATGGGATG
GATTTTGACCCACATAAAGACCCTCAGGTCACTACAGAAGAAAATACTGGAACCTTTGAGATACCA
AATAAAAAAGATAAAGTGAATACCAGGGAAAGTACAGATGTTACGCCTCCAACAAACTCGGAAC
TGCAACTTCAGAAGAAGCCGAATTTATTGTGCCTATGGTACCAAGTTTCCAAGGAGAAGATAGA
GCCAATTGTGGTCACAGAGGGTGATTCCGGTGGTTTTGGAGTGTAACCCGCCACAAGGGATTCCACC
CTGGCAGCTGTACTGGATGACCAATGATCTCCGGCACATTGAGCAGAATGAGAGGGTGTCCATGGG
CCTCAGTGGGAATCTGTACTTCTAATACGCTGGTGTGACAGTCATGATGACTACTGCTGCTTCG
CCTCCTTCTTCAAATAACGCACAATCGTCCAGAAACCCGCATGGTCCCAAGGTCAAGCCAGTTGA
TGCAAAGCAAGAGGATGGTGTGATGCAAGATTGTTACAGGAGAGGAAGCAAGCATCTTGGTTCCT
CCAGTCATTCAACGACTTTCCTGAAAAAAGGAGAAGAGCTGGAGCTGGAGTGATTGCAGAAGGA
CTGCCTACACCGGAGGTAGAATGGATCAAGATATGGGGTGACTTACCAAAGCGCACGCAGATAAAG
AACTTCGGAAAGCTTCTGACAATACCAAACATCAGAGAAGAGGACGAAGGAAAATACATGTGTAA
AGCCAAGAATCAGCATGGTGAAGATGTGCATCATTTCCAGGTCGAAGTAGAGGAGCCACCGAGCT
GGCAGAAGGAGCCGCTGAAGAGTCAGTTAGCATGGATTGGATCTGACATCCACATCAACTGTTCTG
CTACCGGAAAACCGCAACCCACAATCACCTGGAAAAGAAACGGCAAGCCCTCGATGATTTCCCTT
CCACCCATCACAAAATGCTTGACGACAGAATAATCATACTCAAAGCGGAGCAGAAAAGATACCGCTG
TGTACCAGTGTGAGGCCTCCAACAAACACGGCAGCCTACTGGCCAATGCTAATGTGCTAGTCATGAA
TCACCTCCTTTGATTCTGACGAGGAATTATCTGGAGTATGCAACCATGTTGGGCAAGAGTGTGATT
ATGGACTGCAATGTCTTTAGTTCACCACCTGCCACCCTTAACTGGAGAAGAGAAGACCCAGAGGGC
TCTGTAGATGGAGAGAGATATTCTCTGCTGAAGAATGGCTCCCTGCAGATTCACAAAGTCGAGATG
GAAGATATGGCCAGTACAAATGCTTGGCAAACAACCTCCGAGGGCTCTGCAAGCATCACCCTGAA
CTTTTCATTAAAGATTCCACTAGGATCGTGGAGGCTCCTCAAGACATGAAGGTCATCCGGGGATCTG
TGGCCGAGCTGGAGTGCCAGGTGGAGTGCACCCGCTCTCTGAGAAGAGAGCTGGAGTTCGTTTG
GCTCAAAGATGGGATAAATATCCTCTCGAACTCCTCAGAAAGGTATTTTACAGATGAAGGAATTCTT
CAGATATTCAACGTGAGTCACAGTGATCAAGGGAATTACACCTGTATTGTTGCAACATCCCTGGACC
AAGATACAGCTTCTGCATACATAACAGTCTTAGATGTCCCCGATCCTCCGGTTGAATTATTGCTCAGT
GATCTGAAAGACCGCAGTGTGAAGCTCCACTGGGTGAACACCAGTGATCACAACAGTCCATAACA
GAGTTCATCATCCAGTACGAAGAGAGCCACTGGGAGCCAGAGAAGTGGAAGATCTTCTTCGAGT

AGCCAAGAATCAGCATGGTGAAGATGTGCATCATTTCCAGGTCGAAGTAGAGGAGCCACCGAGCT
GGCAGAAGGAGCCGCTGAAGAGTCAGTTAGCATGGATTGGATCTGACATCCACATCAACTGTTCTG
CTACCGGAAAACCGCAACCCACAATCACCTGGAAAAGAAACGGCAAGCCCCTCGATGATTTCCCTT
CCACCCATCACAAAATGCTTGACGACAGAATAATCATACTCAAAGCGGAGCAGAAAGATACCGCTG
TGTACCAGTGTGAGGCCTCCAACAAACACGGCAGCCTACTGGCCAATGCTAATGTGCTAGTCATGAA
TCACCTCCTTTGATTCTGACGAGGAATTATCTGGAGTATGCAACCATGTTGGGCAAGAGTGTGATT
ATGGACTGCAATGTCTTTAGTTCACCACCTGCCACCCTTAAGTGGAGAAGAGAAGACCCAGAGGGC
TCTGTAGATGGAGAGAGATATTCTCTGCTGAAGAATGGCTCCCTGCAGATTCACAAAGTCGAGATG
GAAGATATGGCCAGTACAAATGCTTGGCAAACAACCTCCGAGGGCTCTGCAAGCATCACCCTGAA
CTTTTCATTAAAGATTCACCTAGGATCGTGGAGGCTCCTCAAGACATGAAGGTCATCCGGGGATCTG
TGGCCGAGCTGGAGTGCCAGGTGGAGTGCACCCGCTCTGAGAAGAGAGCTGGAGTTCGTTTG
GCTCAAAGATGGGATAAATATCCTCTCGAACTCCTCAGAAAGGTATTTTACAGATGAAGGAATTCTT
CAGATATTCAACGTGAGTCACAGTGATCAAGGGAATTACACCTGTATTGTTTGAACATCCCTGGACC
AAGATACAGCTTCTGCATACATAACAGTCTTAGATGTCCCCGATCCTCCGGTTGAATTATTGCTCAGT
GATCTGAAAGACCGCAGTGTGAAGCTCCACTGGGTGAACACCAGTGATCACAACAGTCCATAACA
GAGTTCATCATCCAGTACGAAGAGAGCCACTGGGAGCCAGAGAAGTGGAAAGATCTTCTTCGAGT
GTCTAGCAGGAAGTTCTCAGCCCCCTGGCTCTGTAAGTCCACATTAACCTACCAGTTCAGAGTCATCG
CTGTCAATGAAATAGGGAGAAGTCATCCCAGTATGCCCTCAGGAAGATATAAAAACCTCCATGTGC
TCCTGACAGGAACCCAGAAAACATTAAGATTGAGGGTCACTGCCACATCAGATGGACATCAGCTG
GGAGCCGCTCTTGCCGGTGGAGCACAACGGTCCCGGTCTGGAATACAAACTGAGCTACAGGCTCCT
GGGTGTGAGGACAGTTGGAAAGAGCAGATGGTAAAGAGACACTCTTTTGTGGTGCAGACACC
CCGACATTCGTCCCCTATGAAGTCAAATCCAGGCCTTCAACCGCCACGGCTGGGCACCAGGACCC
AAAGTGGTGACTGGTTATTCTGGGGAAGACTTGCCCTGGTGGCTCCCGATAACGTATCTGCGGAG
GTGTTGAACTCTACACTGCTGAAGGTGAGTGGTACCAGTGCCCCAAACCACCTGAGGGGCCAT
CTTGAGGATACACAGTGAACACTGGCAAACCTCAGAGTCTGTTGACCTCTAAGAAAATTCCCTCA
GAGAGACAGTCTCTACCATCCCTGGAAACAGGAGTACACCATGGTGCCAGGACTGAAACCATT
TCTGAATATAGTCTGACTGTCAACGTCTTTAACGGAGAGGGAATGGGCCCAAGCAGCAGTCCCA
TCTCTTTCACAACTCCACAAGGGAGTTCCTGAACAACCTCATAACCTGAAAGCCACAAACTTTCAGA
AAGACGCCATCACACTGGTGTGGGCGCCTCCGCACGAAACCAACGGCCATCTCACAGGATACCTTC
TGCAATACCAAACAGTTGTAGATAATGAGACTCTGGGTGAGTGAACCTCTGTGAACATCTCTGGAG
CAGACACGACACAGTGGGTTTTGCGTGATCTGCAGGAAGACAACCTCATATAAGTTCTACCTGAGTG
CGTGACGCAGGTGGGCTGTGGTCCAGCATCAGTGAGAAAGGAGGCACCGACCCTGCAGCATCT
TCTAGCAGACAAGAGATGGGATCTCAGGAGTGGTTTGGGGATGATGTGCGCGGTGGCTTTGCT
AACTCTGCTTGCCTCATCGGCTGTTTTGTGCTCAAGAACAAAGGTGGCAAATACGCAGTAAAGGA
AAAGGAGAACATTCCAGCTGATCCTGAATCTCATGGCATGGATGAAGAAACACCCTGTGAATACAG
TGACAATGATGAGAAGCCGCTGAAGAGCAGCCAGCAATTGTTCCGAGACGCCACAGAGGATGATC
GCAGTGAGGATAGCTCTGAGATATCAGAGGATGATGACTGCGAGTTCAATGAAGATGGGTCAATCA
TTGGTGAATACTCTGGGTACATGCGCAGGACGTCCACGGCGGTCAACGGATTGAATGGACATACCC
CAGGAACTTCTTAAACAGTGGCCCAATTTTATGAACTTTTAAACAATTCAACAGTAAGAAAGGTTTTG
TTTGAATGGTGTGCCATGAATGTGCCTATGCTTCTGCGTGATTGGGCCAGTTTTTCTACAGTATTAATAT
GAAGGTTGAAAATTTATGATTCTGCGCAA

Notes: The sequence and diagram are color-to-color matching

The protein sequence of camel isoforms

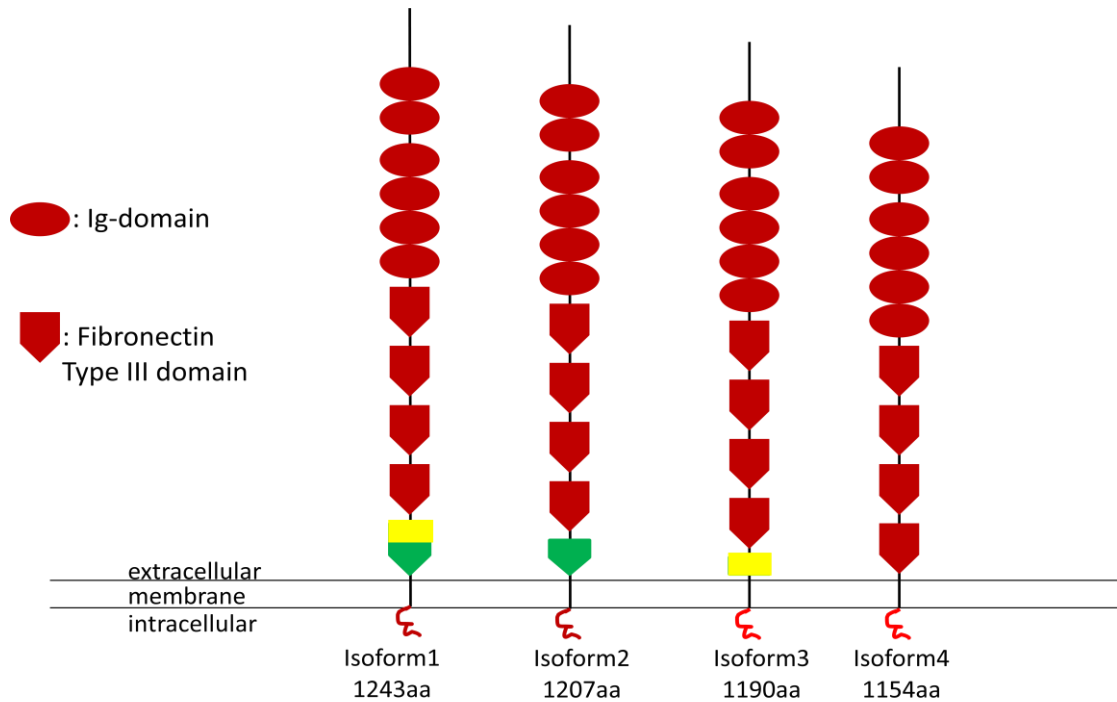

Isoform 1 protein sequence 1243aa

MRGLRSLVGLLSAFFSTTFGLYFPPHVEQLPTITAQTSGTIIALPYDERYIFKCEAKGNRPRTFRWTKDGM
 DFDPHKDPQVTTEENTGTFEIPNKKDKVKYQGKYRCYASNKLGTATSEEAEFIVPMVPKFKPEKIEPIVVTE
 GDSVVLNPPQGIIPWQLYWMTNDRHIEQNERVSMGLSGNLYFSNTLVSDSHDDYCCFASFFKIRTI
 VQKPRMVLKVPVDAKQEDGDAKIVQERKPSILVPSHSTTFLKKGEELEECIAEGLPTPEVEWIKIWD
 LPKRTQIKNFGKLLTIPNIREEDEGKYMCKAKNQHGEDVHHFQVEVEPPSWQKEPLKSQLAWIGSDIHI
 NCSATGKQPQTITWKRNGKPLDDFPSTHHKMLDDRIIILKAEQKDTAVYQCEASNKHGSLLANANVLM
 NHPPLILTRNLEYATMLGKSVIMDCNVFSSPATLNWRREDPEGSVDGERYSLLKNGSLQIHKVEMED
 MGQYKCLANNSEGSASITTELFIKDSTRIVEAPQDMKIVIRGSVAELECQVECDPSLRRELEFVWLKDGINI
 LNSSERYFTDEGILQIFNVSHSDQGNVTCIVRTSLDQDTASAYITVLDVDPPEVLLSLLKDRSVKLVHWV
 NTS DHNSPITEFIIQYEESHWPEKWKDLLRVSSRKFSAPLALYCHINYQFRVI AVNEIGRSHPSMPSGRYK
 TPPCAPDRNPENIKIEGHLPHQMDISWEPLLPVEHNGPGLEYKLSYRLLGVEDSWKEQMVKRHSFVVR
 DTPTFPYEVKIQAFNRHGWAPGPKVVTGYSGEDLPLVAPDNVSAEVLNSTLLKVSWSVPVQTTLRGHL
 GGYTVNYWQTQSLTSSKIPSERQSLTIPGNRSHTMVPGLKPFSEYSLTVNVFNRRGNGPQAAVPSLSQL
 HKGVPEQPHNLKATNFQKDAITLVWAPPHTNGHLTYLLQYQTVVDNETLGELNSVNISGADTTQWV
 LRLDQEDNSYKFYLSACTQVGCESAISEKGGTDPAAFV LNVSTFVRDTSARISWRTRGEHSDS QLYVAIM
 NHRDGIWQLSEALNTSKGFHLVEGLSPGTVYTVRLQASRRVGVPSIFEEVFKTRKASSRQEMGSQEFV
 GMMCAVALLTLLVIGCFVLKNKGGKYAVKEKENIPADPESHGMDEETPCEYSDNDEKPLKSSQQLFRDA
 TEDDRSDESSEISEDDECFNEDGSFIGEYSGYMRRTSTAVNGLNGHTPGTS

Isoform 2 -proteins sequence 1207aa

MRGLRSLVGLLSAFFSTTFGLYFPPHVEQLPTITAQTSGTIIALPYDERYIFKCEAKGNPRPTFRWTKDGM
DFDPHKDPQVTTEENTGTFEIPNKKDKVKYQGKYRCYASNKLGATSEEAEFIVPMVPKFPKEKIEPIVTE
GDSVVLECNPPQGIPPWQLYWMTNDLRHIEQNERVSMGLSGNLYFSNTLVSDSHDDYCCFASFFKIRTI
VQKPRMVLKVKPVDKQEDGDAKIVQERKPSILVSSHSTTFLLKKGEELEECIAEGLPTPEVEWIKIWD
LPKRTQIKNFGKLLTIPNIREEDEGKYMCKAKNQHGEDVHHFQVEVEEPPSWQKEPLKSQLAWIGSDIHI
NCSATGKQPPTITWKRNGKPLDDFPSTHHKMLDDRIILKAEQKDTAVYQCEASNKHGSLLANANVLM
NHPPLILTRNYLEYATMLGKSVIMDCNVFSSPPATLNWRREDPEGSVDGERYSLLKNGSLQIHKVEMED
MGQYKCLANNSEGSASITTELFIKDSTRIVEAPQDMKIVIRGSVAELECQVECDPSLRRELEFVWLKDGINI
LSNSSERYFTDEGILQIFNVSHSDQGNVTCIVRTSLDQDTASAYITVLDVDPPEVLLSCLKDRSVKLVHW
NTSDHNSPITEFIIQYEESHWEPEKWKDLLRVSSRKFSAPLALYCHINYQFRVIAVNEIGRSHPSMPSGRYK
TPPCAPDRNPENIKIEGHLPHQMDISWEPLLPVEHNGPGLEYKLSYRLLGVEDSWKEQMVKRHSFVVR
DTPTFVPEYVKIQAFNRHGWAPGPKVVTGYSGEDLPLVAPDNVSAEVLNSTLLKVSWSVPPQTTLRGHL
GGYTVNYWQTQSLTSSKIPSERQSLTIPGNRSHTMVPGLKPFSEYSLTVNVFNRRNGPQAAVPSLSQL
HKGVPPEQPHNLKATNFQKDAITLVWAPPHTNGHLLTGYLLQYQTVVDNETLGELNSVNISGADTTQWV
LRDLQEDNSYKFYLSACTQVGCESAISEKGGTDPAACDGIWQLSEALNTSKGFHLVEGLSPGTVYTVRLQ
ASRRVGVPSIFEEVFKTRKASSRQEMGSQEWVFGMMCAVALLTLVLIGCFVLKKNKGGKYAVKEKENIPA
DPESHGMDEETPCEYSDNDEKPLKSSQQLFRDATEDDRSEDSSEISEDDCEFNEDGSGFIGEYSGYMRRT
STAVNGLNGHTPGTS

Isoform 3 protein sequence 1190aa

MRGLRSLVGLLSAFFSTTFGLYFPPHVEQLPTITAQTSGTIIALPYDERYIFKCEAKGNPRPTFRWTKDGM
DFDPHKDPQVTTEENTGTFEIPNKKDKVKYQGKYRCYASNKLGATSEEAEFIVPMVPKFPKEKIEPIVTE
GDSVVLECNPPQGIPPWQLYWMTNDLRHIEQNERVSMGLSGNLYFSNTLVSDSHDDYCCFASFFKIRTI
VQKPRMVLKVKPVDKQEDGDAKIVQERKPSILVSSHSTTFLLKKGEELEECIAEGLPTPEVEWIKIWD
LPKRTQIKNFGKLLTIPNIREEDEGKYMCKAKNQHGEDVHHFQVEVEEPPSWQKEPLKSQLAWIGSDIHI
NCSATGKQPPTITWKRNGKPLDDFPSTHHKMLDDRIILKAEQKDTAVYQCEASNKHGSLLANANVLM
NHPPLILTRNYLEYATMLGKSVIMDCNVFSSPPATLNWRREDPEGSVDGERYSLLKNGSLQIHKVEMED
MGQYKCLANNSEGSASITTELFIKDSTRIVEAPQDMKIVIRGSVAELECQVECDPSLRRELEFVWLKDGINI
LSNSSERYFTDEGILQIFNVSHSDQGNVTCIVRTSLDQDTASAYITVLDVDPPEVLLSCLKDRSVKLVHW
NTSDHNSPITEFIIQYEESHWEPEKWKDLLRVSSRKFSAPLALYCHINYQFRVIAVNEIGRSHPSMPSGRYK
TPPCAPDRNPENIKIEGHLPHQMDISWEPLLPVEHNGPGLEYKLSYRLLGVEDSWKEQMVKRHSFVVR
DTPTFVPEYVKIQAFNRHGWAPGPKVVTGYSGEDLPLVAPDNVSAEVLNSTLLKVSWSVPPQTTLRGHL
GGYTVNYWQTQSLTSSKIPSERQSLTIPGNRSHTMVPGLKPFSEYSLTVNVFNRRNGPQAAVPSLSQL
HKGVPPEQPHNLKATNFQKDAITLVWAPPHTNGHLLTGYLLQYQTVVDNETLGELNSVNISGADTTQWV
LRDLQEDNSYKFYLSACTQVGCESAISEKGGTDPAAFVNLNVSTFVRDTSARISWRTRGEHSDSQLYVAIM
NHPSSRQEMGSQEWVFGMMCAVALLTLVLIGCFVLKKNKGGKYAVKEKENIPADPESHGMDEETPCEY
SDNDEKPLKSSQQLFRDATEDDRSEDSSEISEDDCEFNEDGSGFIGEYSGYMRRTSTAVNGLNGHTPGTS

Isoform 4 protein sequence 1154aa

MRGLRSLVGLLSAFFSTTFGLYFPPHVEQLPTITAQTSGTIIALPYDERYIFKCEAKGNPRPTFRWTKDGM
DFDPHKDPQVTTEENTGTFEIPNKKDKVKYQGKYRCYASNKLGATSEEAEFIVPMVPKFPKEKIEPIVTE

GDSVVLECNPPQGIPPWQLYWMTNDRHIEQNERVSMGLSGNLYFSNTLVSDSHDDYCCFASFFKIRTI
VQKPRMVLKVKPVDKQEDGDAKIVQERKPSILVSSHSTTFLKKGEELEECIAEGLPTPEVEWIKIWGD
LPKRTQIKNFGKLLTIPNIREEDEGKYMCKAKNQHGEDVHHFQVEVEPPSWQKEPLKSQQLAWIGSDIHI
NCSATGKPQPTITWKRNGKPLDDFPSTHHKMLDDRIILKAEQKDTAVYQCEASNKHGSLLANANVLM
NHPPLILTRNYLEYATMLGKSVIMDCNVFSSPPATLNWRREDPEGSVDGERYSLLKNGSLQIHKVEMED
MGQYKCLANNSEGSASITTELFIKDSTRIVEAPQDMKVIRGSVAELECQVECDPSLRRELEFVWLKGINI
LSNSSERYFTDEGILQIFNVSHSDQGNVTCIVRTSLDQDTASAYITVLDVDPPEVLLLSDLKDRSVKLHWV
NTSDHNSPITEFIIQYEESHWEPEKWKDLLRVSSRKFSAPLALYCHINYQFRVIAVNEIGRSHPSMPSGRYK
TPPCAPDRNPENIKIEGHLPHQMDISWEPLLPVEHNGPGLEYKLSYRLLGVEDSWKEQMVKRHSFVVR
DTPTFPYEVKIQAFNRHGWAPGPKVVTGYSGEDLPLVAPDNVSAEVLNSTLLKVSWSVPVQTTLRGHL
GGYTVNYWQTQSLTSSKIPSERQSLTIPGNRSHTMVPGLKPFSEYSLTVNVFNRRGNGPQAAVPSLSQL
HKGVPEQPHNLKATNFQKDAITLVWAPPHETNGHLLTYLLQYQTVVDNETLGELNSVNISSGADTTQWV
LRDLQEDNSYKFYLSACTQVGCESAISEKGGTDPAAASSRQEMGSQEFVFGMMCAVALLTLLVLIGCFV
LKNKGGKYAVKEKENIPADPESHGMDEETPCEYSDNDEKPLKSSQQLFRDATEDDRSEDSSEISDDCE
FNEDGSFIGEYSGYMRRTSTAVNGLNGHTPGTS