

Supplementary Material

OMIP-069: Forty-Color Full Spectrum Flow Cytometry Panel for Deep Immunophenotyping of Major Cell Subsets in Human Peripheral Blood

Lily M. Park¹, Joanne Lannigan², and Maria C. Jaimes³

¹Research and Development, Cytex Biosciences, Inc., Fremont, California, 94538-6407

²Flow Cytometry Support Services, LLC, Alexandria, Virginia, 22314

³Research and Development, Cytex Biosciences, Inc., Fremont, California, 94538-6407

INSTRUMENT CONFIGURATION AND INSTRUMENT SETUP OPTIMIZATION

This panel was developed on a Cytek® Aurora (Cytek Biosciences, Fremont, California) equipped with 5 lasers (355, 405, 488, 561, 640 nm) and 64 detectors. In this instrument, the optical design is such that the lasers are spatially separated with independent optical paths. The detection modules consist of avalanche photodiodes (APDs) coupled with narrow bandpass filters ranging from just above the laser wavelength up to 830 nm (**Supplemental Figure 1**). The number of detectors per laser module and bandwidth of the filters is detailed in [Supplemental Table 1](#).

To determine optimal instrument/APD setup, the following approach was taken:

- A comprehensive set of commercially available fluorochromes was identified, making sure to cover as many possible peak emission wavelengths as possible across all 5 lasers.
- Gains were set such that each fluorochrome's peak emission channel corresponds to their maximum emission wavelength, and the spectral patterns did not exhibit any steep changes from one channel to the next.
- PBMCs stained with anti-CD4 labeled with each fluorochrome were acquired at a gain of 50 for each detector across all lasers (range on the Cytek Aurora is from 1 to 3000) and then at 2-fold increments, until the stain index was stable. If, at gain 50, the stain index was already maximal, 2-fold decrease gains were tested. Stain index was calculated using peak channel statistics. The following formula was used:

$$\text{Stain Index} = \frac{\text{MFI}_{\text{positive population}} - \text{MFI}_{\text{negative population}}}{2 * \text{rSD}_{\text{negative population}}}$$

- Gains were then set for optimal stain index in the peak emission channel. If no fluorochrome peaked in a given channel, the gain was adjusted based on an adjacent emitting fluorochrome, so that the signal did not exceed the signal from the peak detector and a smooth transition to the peak channel was maintained.
- To accommodate brighter signals (due to antigens with higher expression level, differences in expression level across donors, or up-regulation of receptors), PBMCs stained with anti-CD8 labeled with each fluorochrome were acquired at the optimal gains established in the previous step and signals verified to be on scale ($< 2 \times 10^6$ on a full scale of 4×10^6). If needed, gains were adjusted proportionately across the detectors to put the brightest signals on scale.
- To identify gains which had the least impact on spillover spread, we compared spread values based on the Spillover Spreading Matrix (SSM) at different gains; using the gains established in the previous step, and with a 2- and 4-fold increase, to ensure the lower gains minimized spread values.
- The final gain settings were saved in the SpectroFlo® software as CytekAssaySetting. These settings are automatically updated during daily QC based on calibrated bead MFI targets to ensure consistent setup across days.

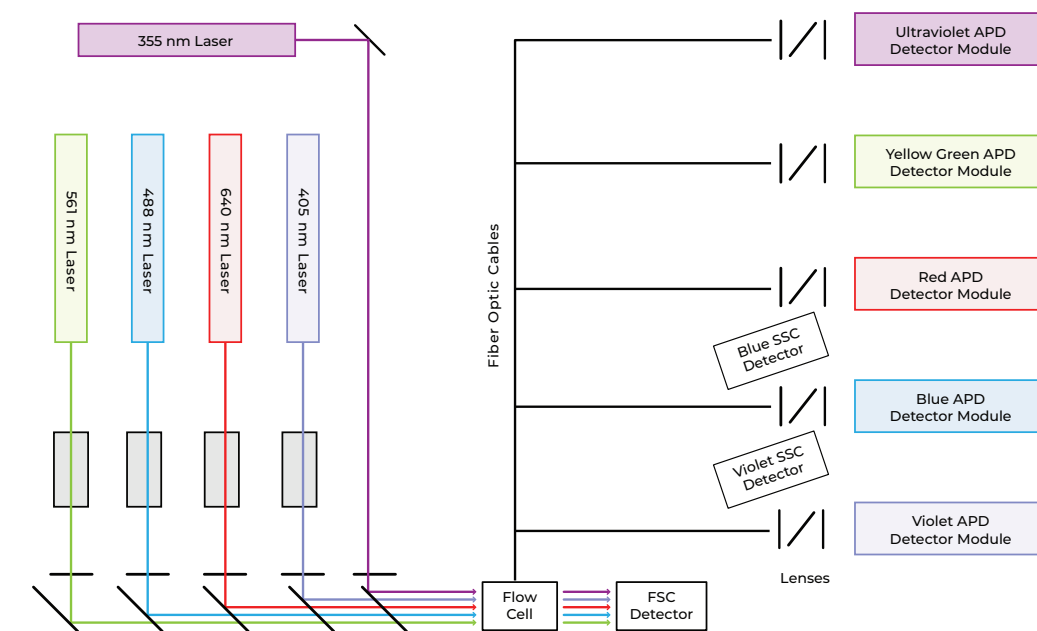

Supplemental Figure 1. Schematic of Optical Layout for 5 Laser Aurora

The Cytek Aurora used to develop the panel was equipped with 5 lasers. The optical paths for each of the 5 lasers (UV 355 nm, Violet 405 nm, Blue 488 nm, Yellow Green 561 nm, and Red 640 nm) are represented. The lasers are spatially separated, each has an independent optical path, and through optical fibers light is directed to individual detector modules using avalanche photodiodes (APD) as photodetectors.

UV (355 nm - 20 mW)			Violet (405 nm - 100 mW)			Blue (488 nm - 50 mW)			Yellow Green (561 nm - 50 mW)			Red (640 nm - 80 mW)		
Detector	Center Wavelength	Bandwidth	Detector	Center Wavelength	Bandwidth	Detector	Center Wavelength	Bandwidth	Detector	Center Wavelength	Bandwidth	Detector	Center Wavelength	Bandwidth
1	372.5	15	1	427.5	15	1	508	20	1	577	20	1	661	17
2	387.5	15	2	443	15	2	524.5	17	2	598	20	2	679	18
3	427.5	15	3	458	15	3	541.5	17	3	615	20	3	697	19
4	443	15	4	473	15	4	580.5	19	4	661	17	4	717	20
5	458	15	5	508	20	5	598	20	5	679	18	5	738	21
6	473	15	6	524.5	17	6	615	20	6	697	19	6	760	23
7	514	28	7	541.5	17	7	661	17	7	720	29	7	783	23
8	542	28	8	580.5	19	8	679	18	8	749.5	30	8	811.5	34
9	581.5	31	9	598	20	9	697	19	9	779.5	30			
10	612.5	31	10	615	20	10	717	20	10	811.5	34			
11	664	27	11	664	27	11	738	21						
12	691.5	28	12	691.5	28	12	760	23						
13	720	29	13	720	29	13	783	23						
14	749.5	30	14	749.5	30	14	811.5	34						
15	779.5	30	15	779.5	30									
16	811.5	34	16	811.5	34									

Supplemental Table 1. Detector Modules Configuration for 5 Laser Aurora

The detectors and wavelength information of the bandpass filters associated with each laser detector are listed. UV laser detector module: 16 detectors (UV1-UV16); violet laser detector module: 16 detectors (V1-V16); blue detector module: 14 detectors (B1-B14); yellow green laser detector module: 10 detectors (YG1-YG10); red laser detector module: 8 detectors (R1-R8). Wavelengths of the filters are continuous, except for wavelengths associated with the laser line emissions (UV2-UV3, UV6-UV7, UV8-UV9, UV10-UV11, V4-V5, V7-V8, V10-V11, B3-B4, B6-B7, YG3-YG4).

STRATEGY FOR FLUOROCHROME SELECTION AND FLUOROCHROME CHARACTERIZATION

The first step for the panel development consisted of identifying the best possible 40 fluorochrome combination. The following criteria were applied for this selection:

- **Unique spectra:** The spectra of over 65 commercially available fluorochromes were analyzed. Fluorochromes with peak emissions occurring in different channels were identified, as well as fluorochromes that, despite sharing the same peak emission, have a different spectrum. Next, the fluorochrome signature uniqueness, determined by comparing the full spectrum across all 64 detectors, was quantified using an index developed by Cytex Biosciences, and available through the SpectroFlo software, called Similarity Index. This index uses the cosine of the angle between the vectors defined for each fluorochrome in a 64-dimensional space to compare two signatures. This index ranges from 0 to 1; 0 indicating the 2 fluorochromes do not share any spectral characteristics, and 1 indicating that the spectra are identical. Based on testing of multiple fluorochrome combinations, it was determined that similarity indices of 0.98 or less indicated that fluorochromes were different enough to be used together.
- **Overall fluorochrome combination compatibility:** This assessment was guided by a Cytex developed metric, also available in the SpectroFlo software, called the Complexity Index. This index measures the interference among a specific combination of fluorochromes and predicts the impact on the autofluorescence distribution of the spectrally unmixed results while also considering spillover (1.2). The lower the complexity index, the higher the probability that the fluorochrome combination will work together and yield high resolution data through reduced spread. Similarity Index and Complexity Index together provide a measure of the degree of overall interferences due to spillover between and among fluorochromes. Note: Similarity and Complexity Indices are currently under patent application. Once issued, formulas will be made publicly available.

Based on the above criteria, 40 fluorochromes were selected ([Supplemental Figures 2A and 2B](#)), minimizing fluorochrome pairs with very high similarity indices and providing the lowest complexity index (complexity index=54). The distribution of the selected fluorochromes across lasers and emission wavelengths is presented in [Supplemental Table 2](#). The pairs with the highest similarity indices, and hence higher predicted spread between them, were BB515 and FITC (0.98), BV421 and Super Bright 436 (0.97), Super Bright 436 and eFluor 450 (0.94), and Alexa Fluor 647 and Spark NIR 685 (0.92). Additionally, an effort was made to minimize the use of custom reagents. Out of the 40 fluorochromes used in this panel, only one is custom, and is commercially available through BioLegend® (San Diego, CA): PE-Fire 810. This fluorochrome was selected to take advantage of the high detection efficiency that APDs have in the far-red range of emission.

Next, the selected 40 fluorochromes were ranked for brightness using anti-CD4 single stained cells available for 38 of the fluorochromes, and using HLA-DR PE-Fire 810 and CD38 APC-Fire 810 ([Supplemental Figure 2C](#)). Finally, spread was assessed by calculating the SSM using FlowJo™ version 10.6.2 with the same data used to rank fluorochrome brightness ([Supplemental Figure 2D](#)). As expected, based on the spectrum and similarity indices, the pairs with the highest SSM values were BB515 into FITC (SSM=29) and FITC into BB515 (SSM=23). Other combinations showing high spread were APC into Alexa Fluor 647 (SSM=14.2), Spark Blue 550 into FITC (SSM=13.2), BUV661 into APC (SSM=11.7), and BV480 into BV510 (SSM=11.45). Of the 1,560 combinations of fluorochromes, only 13 had an SSM greater than 10, with the majority (91%) having SSM values of 4 or less. Differences of 10-fold in the SSM are equivalent to approximately a log greater spread in the data (3).

PANEL DESIGN STRATEGY

Basic principles for best practices for panel design based on previously published approaches used for conventional cytometry were followed (4). Antigens were classified as primary, secondary, and tertiary based on level of expression, and co-expression was assessed using a schematic gating tree and researching the expression for each marker on the subsets of interest. Next, fluorochrome assignment was made following these steps:

Step 1: Assignment of Fluorochromes with Limited Conjugate Availability

In order to minimize the use of custom reagents, there were limitations on the fluorochrome assignment for certain markers:

- HLA-DR PE-Fire 810, a custom reagent, was readily available through BioLegend® and fit into the panel.
- CD38 APC-Fire 810 was originally a custom conjugate but is now commercially available ([Supplemental Table 4](#)).

2C

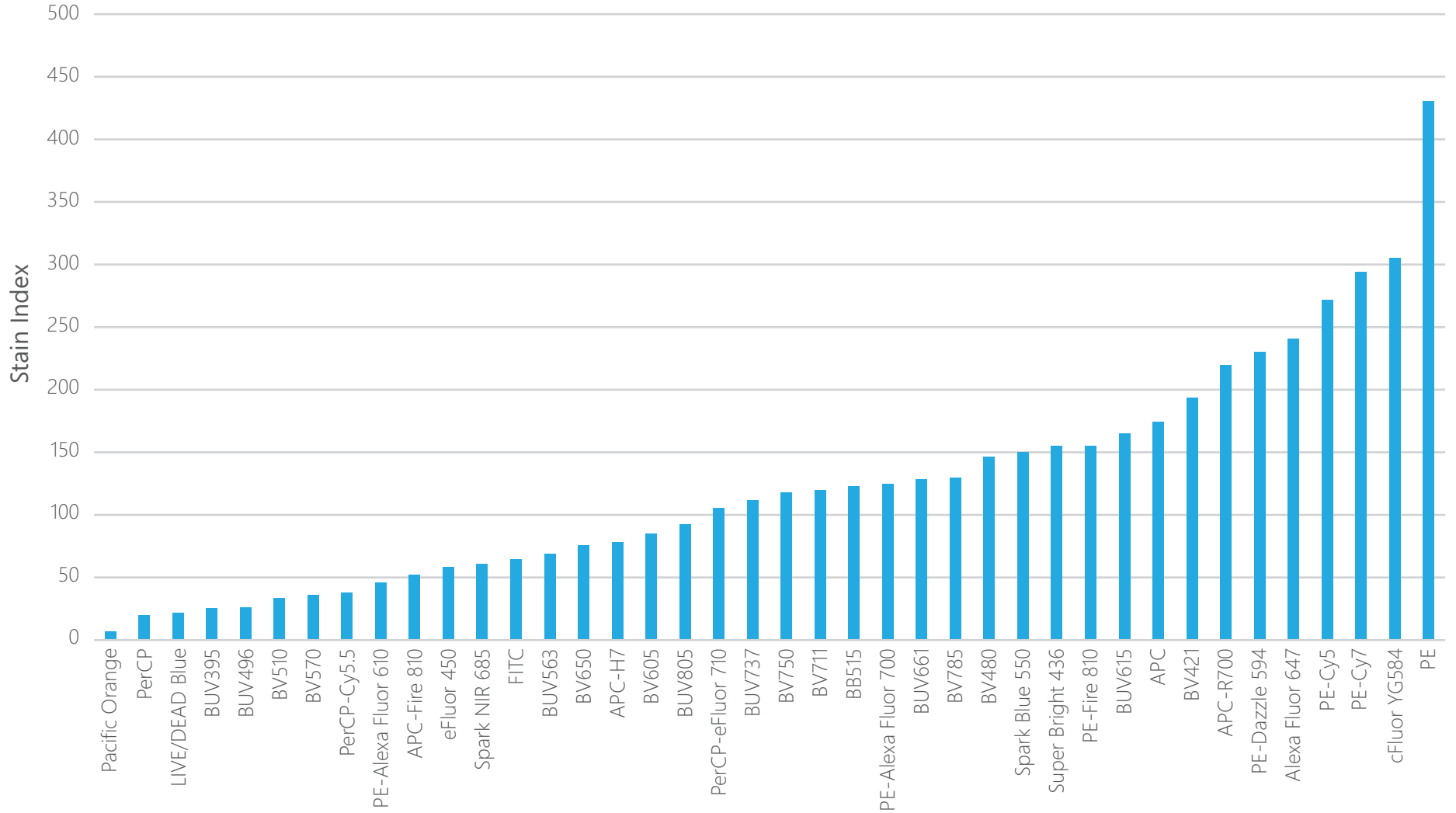

	BUV395	LIVE/DEAD Blue	BUV496	BUV563	BUV615	BUV661	BUV737	BUV805	BV421	Super Bright 436	eFluor 450	BV480	BV510	Pacific Orange	BV570	BV605	BV650	BV711	BV750	BV785	BB515	FITC	Spark Blue 550	PerCP	PerCP-Cy5.5	PerCP-eFluor 710	PE	cFluor YG584	PE-Dazzle 594	PE-Alexa Fluor 610	PE-Cy5	PE-Alexa Fluor 700	PE-Cy7	PE-Fire 810	APC	Alexa Fluor 647	Spark NIR 685	APC-R700	APC-H7	APC-Fire 810	Sum	
BUV395		2.19	0.00	0.00	0.04	0.00	0.00	0.55	0.00	0.00	1.14	0.00	3.27	0.00	0.87	0.74	1.43	1.12	0.65	0.00	0.00	0.00	0.00	0.00	0.00	0.00	0.00	0.00	0.09	1.48	0.00	0.78	0.74	0.00	1.95	0.00	0.00	0.58	0.00	0.00	18.27	
LIVE/DEAD Blue	4.55		7.51	1.32	0.50	0.81	0.34	0.00	3.21	4.32	5.76	2.45	9.64	5.51	1.75	1.05	1.39	0.00	0.00	0.26	2.66	1.11	2.48	0.00	0.73	0.00	1.79	1.96	2.99	0.91	1.69	0.26	0.00	1.07	0.00	0.00	0.26	0.33	0.00	0.00	68.61	
BUV496	0.81	1.09		1.77	0.81	0.44	0.25	0.39	0.58	1.55	0.98	1.53	5.91	5.30	1.96	1.02	0.61	0.32	0.03	0.33	6.31	6.00	1.38	0.00	0.55	0.50	0.04	0.67	0.00	0.00	0.43	0.00	0.00	0.00	0.43	0.00	0.00	0.00	0.00	0.00	0.00	41.56
BUV563	0.46	0.62	0.00		1.50	0.81	0.41	0.71	0.00	0.54	0.00	0.68	2.24	1.55	1.25	0.75	0.61	0.00	0.00	0.00	0.00	1.94	0.98	2.02	1.08	0.45	4.15	7.32	4.38	4.12	2.90	0.65	0.01	0.00	1.17	2.22	1.12	0.39	0.00	0.33	47.37	
BUV615	0.67	0.67	0.00	2.25		2.84	2.60	3.02	0.28	1.04	0.04	0.28	0.00	0.00	0.00	1.88	1.31	1.00	1.07	0.79	1.17	2.18	0.44	2.68	2.15	1.97	5.68	2.81	6.14	4.62	3.81	1.75	1.01	0.52	2.58	3.75	2.15	1.28	0.55	0.46	67.41	
BUV661	0.58	0.58	0.00	0.69	0.00	3.35	3.08	0.80	1.05	0.69	0.00	0.00	0.98	0.00	0.00	0.82	2.59	1.80	1.35	1.17	1.97	0.00	0.68	3.16	2.33	2.42	1.16	0.49	3.69	3.79	5.54	2.57	1.13	0.67	5.40	11.70	6.74	2.90	1.70	1.33	78.88	
BUV737	0.80	0.98	0.00	0.00	0.00	0.74		6.22	0.79	0.00	0.00	0.00	0.00	0.00	0.09	0.00	0.00	1.92	3.20	2.23	0.00	0.00	0.00	1.97	2.73	4.00	0.68	0.00	0.00	0.88	0.00	2.72	1.16	1.08	1.72	2.96	3.91	4.06	2.44	1.98	49.26	
BUV805	1.15	1.08	0.00	0.00	0.40	0.00	1.33		0.74	0.81	0.59	0.80	1.14	0.00	0.00	0.04	0.59	0.49	1.57	0.00	0.00	0.00	0.00	0.00	0.00	0.54	0.00	0.58	0.05	0.00	0.02	0.72	0.69	0.77	0.57	0.70	0.47	1.60	2.10	19.54		
BV421	0.27	0.93	1.52	0.39	0.24	0.00	0.00		9.84	5.25	2.42	6.09	4.76	1.44	0.78	0.00	0.00	0.42	1.69	0.00	0.00	0.42	1.69	0.00	0.00	0.01	0.58	0.51	0.00	0.59	0.00	0.20	0.00	0.28	0.00	0.00	0.03	0.00	0.00	2.19	39.25	
Super Bright 436	0.20	0.83	0.00	0.00	0.00	0.18	0.00	5.16		4.73	2.52	6.54	5.59	1.51	0.77	0.44	0.41	0.00	0.00	0.98	2.73	0.06	0.00	0.03	0.00	0.30	0.71	0.00	0.76	0.00	0.00	0.00	0.19	0.00	1.08	0.00	0.40	0.00	0.00	36.12		
eFluor 450	0.00	1.11	0.00	0.00	0.00	0.00	0.00	5.45	10.36		2.78	6.25	5.21	1.85	0.67	0.94	0.61	0.59	0.95	0.00	0.00	0.00	0.55	0.00	0.00	0.53	0.00	0.00	0.00	0.00	0.00	0.36	0.34	0.56	0.00	0.87	0.41	0.38	0.42	41.16		
BV480	0.30	0.76	3.40	1.90	0.61	0.26	0.18	0.28	1.98	3.74	2.50		11.48	10.45	4.14	2.15	0.71	0.62	0.58	0.58	7.26	7.27	1.95	0.52	0.51	0.00	1.05	1.22	1.30	0.73	0.54	0.00	0.00	0.01	0.00	0.00	0.87	0.23	0.01	0.33	70.36	
BV510	0.26	1.14	1.36	2.35	1.13	0.67	0.29	0.78	1.36	2.81	1.66	2.41		8.76	4.45	2.55	1.36	0.92	0.65	0.83	3.29	0.00	0.71	0.00	1.22	0.00	1.41	1.02	1.10	1.39	0.00	0.00	0.31	0.30	0.00	2.40	0.00	0.82	0.00	0.53	50.23	
Pacific Orange	0.00	0.16	0.00	1.11	0.00	0.00	1.10	0.00	2.18	0.00	0.00	1.72	0.00		5.15	3.03	2.11	1.48	1.22	0.86	0.00	0.00	0.00	0.00	0.00	0.00	1.05	0.00	0.00	1.70	0.00	0.00	0.00	1.14	1.46	0.00	0.00	0.00	0.00	25.48		
BV570	0.00	0.97	0.00	0.50	0.78	0.42	0.39	0.31	1.95	2.91	1.70	1.05	0.00	2.61		2.64	1.71	0.64	0.96	0.88	0.00	0.00	0.00	2.05	1.24	0.03	2.66	3.35	3.63	3.48	2.43	0.88	0.00	0.29	1.62	2.07	0.91	0.50	0.00	0.00	45.56	
BV605	0.17	0.94	0.00	0.00	1.64	0.95	0.87	1.01	1.08	1.60	0.89	0.28	0.00	0.00	1.49		2.14	1.40	1.43	1.42	0.00	0.00	0.00	2.55	1.90	1.42	6.12	3.92	5.72	4.73	3.64	1.50	0.78	0.55	2.06	3.62	1.84	0.84	0.21	0.23	58.92	
BV650	0.00	1.14	0.00	0.00	0.43	1.30	0.93	1.21	1.02	2.50	1.32	0.60	2.03	1.30	0.00	1.17		1.80	2.06	1.80	0.00	0.00	0.00	1.57	1.53	1.42	1.06	0.00	2.60	2.57	2.65	1.40	0.62	0.53	2.85	4.73	3.20	1.14	0.77	0.52	49.76	
BV711	0.26	0.86	0.00	0.00	0.57	1.77	2.29	1.40	2.37	1.20	0.70	0.58	1.30	0.32	0.00	0.82		3.96	3.64	0.98	0.00	0.46	1.27	1.97	1.99	0.80	0.00	0.00	0.79	0.66	3.00	0.86	0.66	1.68	3.28	3.47	2.91	1.42	1.15	49.39		
BV750	0.15	0.98	0.00	0.00	0.00	0.20	2.49	2.84	1.14	2.01	0.73	0.84	1.49	0.00	0.47	0.48	0.39	1.51		5.43	0.00	0.85	0.34	0.00	0.95	1.11	0.00	0.53	0.88	0.62	0.66	0.72	0.75	0.60	0.34	1.14	1.28	1.28	1.19	1.39	35.66	
BV785	0.34	0.75	0.00	0.00	0.17	2.20	3.03	1.54	2.14	1.21	0.46	0.87	0.38	0.00	0.34	0.54	0.65	3.01		0.90	0.00	0.00	0.82	0.39	0.56	0.38	0.37	0.00	0.54	0.41	0.41	0.43	0.73	0.62	0.60	0.67	0.92	0.44	1.28	1.30	28.20	
BB515	0.00	0.58	0.00	0.23	0.00	0.13	0.00	0.00	0.00	0.78	0.57	0.90	5.13	5.58	1.89	0.79	0.38	0.00	0.00	0.30		28.98	7.65	0.96	0.57	0.33	1.85	1.83	1.65	1.07	1.08	0.17	0.20	0.14	0.23	0.30	0.49	0.00	0.00	0.00	64.74	
FITC	0.00	0.00	0.00	0.00	0.44	0.29	0.00	0.00	1.26	0.00	1.07	3.94	5.56	1.85	0.71	0.81	0.64	0.00	0.37	23.33		6.60	0.00	0.00	0.71	2.02	2.31	1.45	1.69	1.32	0.62	0.00	0.00	1.50	0.00	1.52	0.36	0.00	0.60	0.60	60.96	
Spark Blue 550	0.12	1.13	1.31	0.10	0.51	0.00	0.26	0.30	0.45	0.00	0.00	0.74	2.90	6.50	3.66	1.56	1.02	0.68	0.61	0.49	10.25	13.17		3.10	2.15	1.42	4.08	3.58	3.68	2.68	2.56	0.77	0.58	0.56	0.94	2.30	1.52	0.48	0.00	0.00	76.13	
PerCP	0.00	0.00	0.00	0.00	0.90	1.04	1.12	1.71	0.00	0.00	0.91	0.00	3.11	0.00	0.13	3.37	1.12	1.13	1.34	0.00	1.78	0.00		5.24	3.28	1.70	0.00	5.61	6.20	7.28	1.96	1.16	0.00	4.72	5.61	4.16	1.68	0.00	0.92	67.17		
PerCP-Cy5.5	0.00	1.83	0.00	0.00	1.19	1.77	2.34	0.94	0.00	0.00	0.00	0.00	0.00	0.00	0.00	3.02	2.84	2.68	2.48	0.00	4.39	1.28	9.48		5.63	1.84	0.00	4.93	5.86	6.79	4.91	2.28	1.91	4.69	8.19	6.32	2.90	1.67	1.75	93.92		
PerCP-eFluor 710	0.00	1.18	0.00	0.00	0.69	1.66	2.14	0.69	0.00	0.39	0.00	0.00	0.00	0.92	0.36	1.60	4.63	3.23	2.87	1.96	0.00	0.62	6.01	6.89		2.17	0.00	2.55	2.96	3.37	8.12	2.57	2.31	2.78	5.66	5.14	3.68	2.03	1.60	80.80		
PE	0.00	0.40	0.00	1.22	0.45	0.35	0.14	0.16	0.29	0.45	0.36	0.22	0.29	0.96	2.42	1.34	0.79	0.42	0.28	0.13	1.22	2.02	0.73	2.66	1.54	0.93		9.88	6.10	5.37	3.89	0.91	0.40	0.29	1.39	2.50	1.29	0.46	0.00	0.19	52.42	
cFluor YG584	0.00	0.00	0.00	0.57	0.41	0.30	0.01	0.28	0.00	0.96	0.00	0.00	1.29	0.39	1.54	1.08	0.85	0.36	0.36	0.26	0.00	1.51	0.36	2.34	1.62	1.05	4.05		5.64	5.36	3.92	1.43	0.76	0.39	1.62	2.38	1.68	0.58	0.00	0.16	43.53	
PE-Dazzle 594	0.27																																									

Approx. Emission Wavelength (nm)	UV	Violet	Blue	Yellow Green	Red
395	BUV395				
420		BV421			
440		Super Bright 436			
450	Viability UV (L/D Blue)	eFluor 450			
480		BV480			
500	BUV496		BB515		
520		BV510	FITC		
550		Pacific Orange	Spark Blue 550		
570	BUV563	BV570/Pacific Orange			
580				cFluor YG584/PE	
600	BUV615	BV605		PE-Dazzle 594	
660	BUV661	BV650		PE-Alexa Fluor 610	APC
680			PerCP	PE-Cy5	Alexa Fluor 647
690			PerCP-Cy5.5		Spark NIR 685
700		BV711	PerCP-eFluor 710	PE-Alexa Fluor 700	APC-R700
730	BUV737				
750		BV750			
780		BV785		PE-Cy7	APC-H7
800	BUV805			PE-Fire 810	APC-Fire 810

Supplemental Table 2. Fluorochrome Optical Layout

Fluorochromes intended for use in the OMIP-069 panel are presented by primary laser excitation (columns) and approximate emission wavelengths of the peak detector (rows). Fluorochromes which peaked in the same detector (cFluor YG584 and PE; BV570 and Pacific Orange) are shown as sharing the same emission block. This table layout provided the information regarding potential sources of spread and helped to inform the assignment of markers to fluorochromes to minimize any loss of population resolution.

- CD4 was the only reagent commercially available in cFluor YG584.
- There were limited choices for PE-Alexa Fluor 700, of which CD25 was the only option based on the markers in the panel.
- There were limited choices for PE-Alexa Fluor 610, of which CD24 was the only option based on the markers in the panel.

Step 2: Selection of Viability Dye

LIVE/DEAD™ Fixable Blue (Thermo Fisher, Waltham, MA) was selected for assessing viability as it has a unique signature that does not interfere with the use of other UV excitable fluorochromes.

Step 3: Assignment of Fluorochromes Based on Primary Antigen Classification and Co-Expression

Dimmest fluorochromes were assigned to antigens expressed at high levels and with high level of co-expression with other markers in the panel, while also minimizing spread:

- CD45 in PerCP, co-expressed with all markers in the panel
- CD20 in Pacific Orange, co-expressed with all B cell makers
- CD45RA in BUV395, co-expressed with a high number of markers
- CD3 in BV510, co-expressed with all T cell markers
- CD16 in BUV496, co-expressed with all NK and monocyte markers
- CD2 in PerCP-Cy5.5, co-expressed with T cells and NK cell markers
- CD8 in BUV805, high antigen density

Step 4: Assignment of Fluorochromes Based on Tertiary Antigen Classification

Next, to maximize resolution, tertiary markers were assigned to bright fluorochromes, trying when possible to use fluorochromes whose signals were not severely impacted by spread from multiple fluorochromes. Moreover, information about clones/performance from previous panels developed and tested in the lab was used to make these selections:

- CD123 in Super Bright 436, used successfully in previous panels
- CD1c in Alexa Fluor 647, per OMIP-044 (5)
- CD141 in BB515
- TCR $\gamma\delta$ in PerCP-eFluor 710, used successfully in previous panels
- CD159a in APC, desired clone from OMIP-039 (6) with limited availability, no co-expression or loss of resolution with CD1c Alexa Fluor 647
- CD159c in PE, desired clone from OMIP-039 (6) with limited availability, no co-expression or loss of resolution with CD4 cFluor YG584
- PD-1, originally tested in BV650, in BV785 with improved resolution (data not shown)
- CXCR3 and CXCR5 in PE-Cy7 and BV750, respectively, both used successfully in previous panels

Step 5: Assignment of Fluorochromes for Remaining Markers

Finally, for the remaining markers (mainly secondary antigen markers), it was important to take into consideration possible sources of spread that could impact resolution utilizing [Supplemental Table 2](#) and assign markers so that the following two conditions were met:

- Regarding fluorochromes in columns (indicating primary excitation laser): avoid highly expressed antigens being placed in cells adjacent to co-expressed antigens with lower expression.
- Regarding fluorochromes in rows (indicating similar emission wavelength): avoid highly expressed antigens being placed in cells on the same row as co-expressed markers with lower expression.

Beginning with assignments within the same column/primary laser excitation:

- CD56 in BUV737, previous experience indicated no impact on CD8 BUV805 resolution
- CCR7 in BV421, no co-expression or loss of resolution with CD123 Super Bright 436
- IgD in BV480, no co-expression or loss of resolution with CD3 BV510
- CD11c in eFluor 450, high level of expression, no co-expression or loss of resolution with CD123 Super Bright 436 or IgD BV480
- IgM in BV570 and IgG to BV605, mutually exclusive expression and resolution not impacted by CD20 Pacific Orange
- CD57 in FITC, used in previous panels, no co-expression or loss of resolution with CD141 BB515
- CD14 in Spark Blue 550, no co-expression with CD57 FITC and testing showed no loss of resolution
- CD337 in PE-Dazzle 594, no co-expression or loss of resolution with CD4 cFluor YG584 or CD24 PE-Alexa

Fluor 610

- CD19 in Spark NIR 685, limited reagent availability, no co-expression or loss of resolution with CD1c Alexa Fluor 647
- CD127 in APC-R700, used in previous panels, no co-expression or loss of resolution with CD19 Spark NIR 685. Of note, CD127 clone A019D5 was originally tested in APC-Fire 750, but severe loss of signal was observed in the multicolor tube. We then switched to clone HIL-7R-M21 and tested in parallel BUV737 and APC-R700, and consistent results were only achieved with the APC-R700 conjugate and hence this reagent was selected.

Next steps focused on the remaining assignments per row/emission wavelength:

- CD16 in BUV496, used in previous panels with good resolution and no co-expression or loss of resolution with CD141 BB515
- CCR5 in BUV563, low level of expression mitigated spread into CD4 cFluor YG584
- CD314 in BUV615, low level of expression mitigated spread into CD337 PE-Dazzle 594
- CD39 in BUV661, low level of expression, and no co-expression with CD1c, mitigated spread into Alexa Fluor 647
- CD28 in BV650, no co-expression or loss of resolution with CD159a APC
- CD95 in PE-Cy5, used in previous panels with good resolution and no co-expression or loss of resolution with CD1c Alexa Fluor 647 or CD159a APC
- CCR6 in BV711, low level of expression mitigated spread into other ~700 nm emitting fluorochromes
- CD27 in APC-H7, used in previous panels with good resolution and no spread into other fluorochromes

The distribution of the final panel of reagents across lasers and emission wavelengths is presented in [Supplemental Table 3](#).

PANEL TESTING

Once the theoretical panel design was finalized, testing of the panel included the following steps:

Step 1: Antibody Titration

All reagents were titrated using frozen PBMCs, at an average of 100,000 cells per test. The cells were resuspended in a final volume of 200 μ l of staining buffer (BD Stain Buffer) to mimic the final staining volume of the multicolor (MC) tube. The antibodies that came bottled for use at 5 μ l/test were tested in 2-fold serial dilutions ranging from 10 μ l to 0.15 μ l per test, and the antibodies that came bottled at a concentration in μ g/ml were tested from 1 μ g (1000 ng) to 15 ng per test. In both cases, titers were reported in nanograms (ng) per test ([Supplemental Figure 3](#)). Note that the selected titer was not necessarily the optimal titer (higher stain index) in the single stained titration. This was a result of performance comparison of the single stain (SS) to the MC samples, see [step 4 below](#) ([Supplemental Figure 6B](#)).

Step 2: Reference Control Optimization ([Supplemental Figure 4](#))

As for compensation, the unmixing accuracy is highly dependent on the quality of the reference controls and their ability to accurately represent the spectra of fluorochromes present in the MC staining. Using a full spectrum flow cytometer allows detection of even the smallest differences in fluorochrome emission. It is a well known phenomena that fluorochrome antibodies bound to beads vs. cells can produce slight differences in the spectra that are emitted ([7](#)). To determine which reference control materials could be used to produce identical spectra for the fully stained sample, both beads and cells were tested. For this purpose, beads and cells stained with exactly the same reagents included in the panel were tested in parallel. Unmixing accuracy using beads as controls was tested by evaluating the unmixing results of the SS cells. For some of the markers/fluorochromes, the use of a bead reference control led to unmixing inaccuracies. Errors were identified with the following fluorochromes: BUV496, BUV563, BUV661, BUV805, BV480, BV570, Spark Blue 550, PE-Cy5, APC, and APC-Fire 750. See [Supplemental Figure 4](#) for two examples where such an error occurred. In order to fully document why errors were observed, the normalized full spectrum of each of these dyes when the antibody was bound to the beads was compared to the normalized full spectrum of the same fluorochrome when the antibody was bound to cells. As expected, differences in the spectrum in specific wavelength regions fully correlated with the unmixing errors observed ([Supplemental Figure 4](#)). Beads could potentially be used for controls for all other fluorochromes. In the experiments run for this publication, cells were always used as controls and used to evaluate panel performance, see [step 4 below](#).

Approx. Emission Wavelength (nm)	UV	Violet	Blue	Yellow Green	Red
395	CD45RA BUV395				
420		CCR7 BV421			
440		CD123 Super Bright 436			
450	Viability UV (L/D Blue)	CD11c eFluor 450			
480		IgD BV480			
500	CD16 BUV496		CD141 BB515		
520		CD3 BV510	CD57 FITC		
550			CD14 Spark Blue 550		
570	CCR5 BUV563	IgM BV570/ CD20 Pacific Orange			
580				CD4 cFluor YG584/ CD159c PE	
600	CD314 BUV615	IgG BV605		CD337 PE-Dazzle 594	
660	CD39 BUV661	CD28 BV650		CD24 PE-Alexa Fluor 610	NKG2A APC
680			CD45 PerCP	CD95 PE-Cy5	CD1c Alexa Fluor 647
690			CD2 PerCP-Cy5.5		CD19 Spark NIR 685
700		CCR6 BV711	TCR $\gamma\delta$ PerCP-eFluor 710	CD25 PE-Alexa Fluor 700	CD127 APC-R700
730	CD56 BUV737				
750		CXCR5 BV750			
780		PD-1 BV785		CXCR3 PE-Cy7	CD27 APC-H7
800	CD8 BUV805			HLA-DR PE-Fire 810	CD38 APC-Fire 810

Supplemental Table 3. Fluorochrome and Reagent Optical Layout

Using the information from [Supplemental Table 2](#), assignment of fluorochromes to antigens were based on 1) reagent fluorochrome availability, 2) whether an antigen was classified as primary, secondary, and tertiary based on level of expression, and 3) co-expression assessed based on a schematic gating tree. Assignments were also made based on the following goals: 1) avoid highly expressed antigens being placed in adjacent cells in the same column (indicating primary excitation laser) as co-expressed antigens with lower expression; and 2) avoid highly expressed antigens being placed in cells on the same row (indicating similar emission wavelength) as co-expressed markers with lower expression.

3A

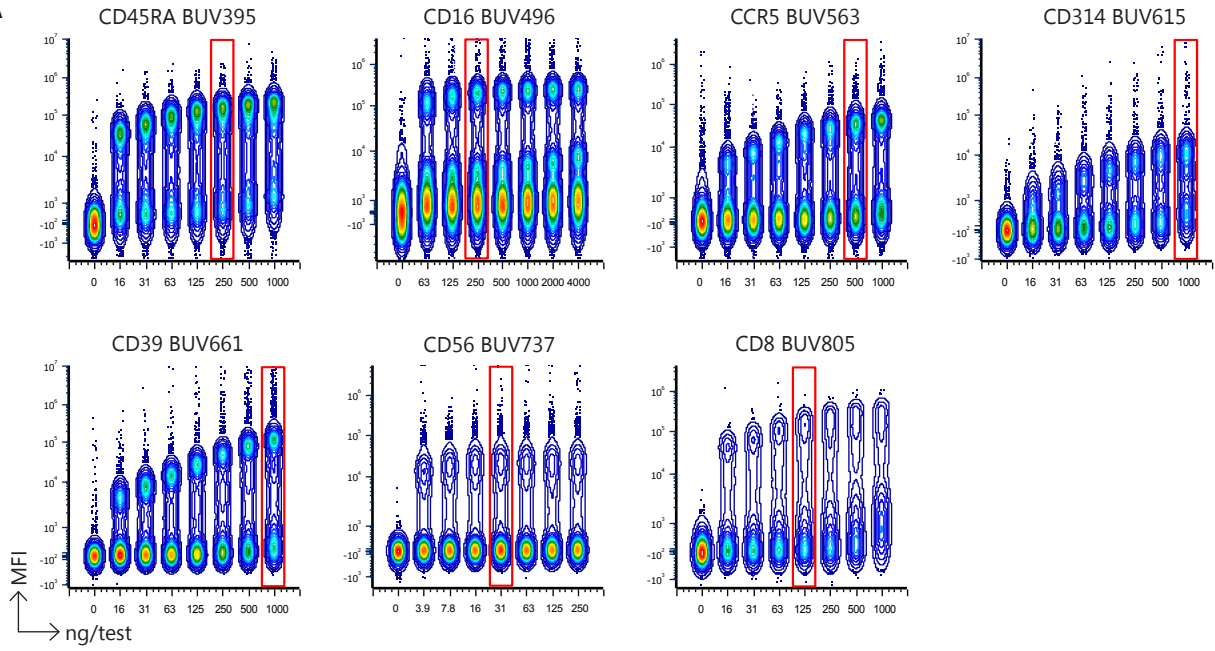

3B

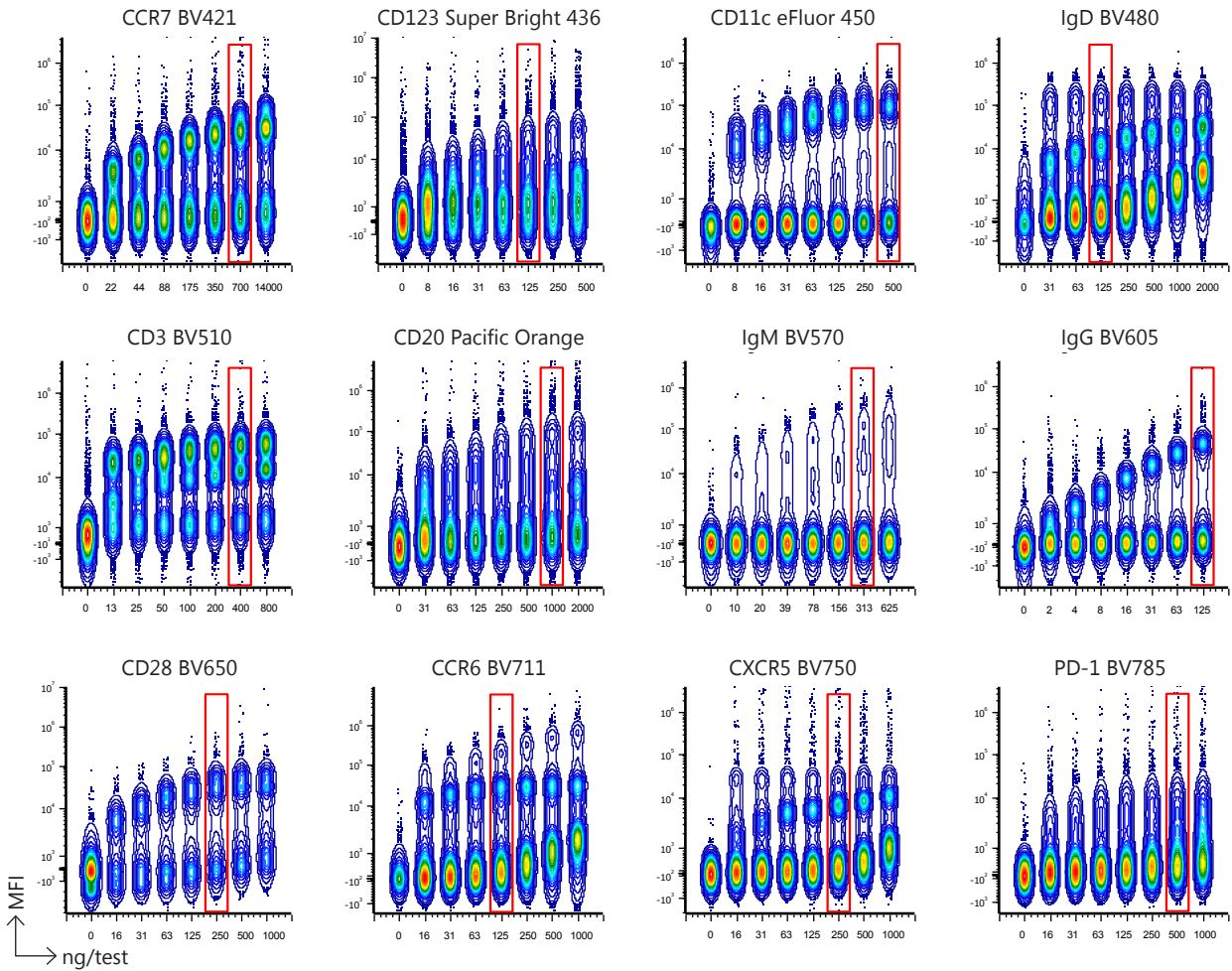

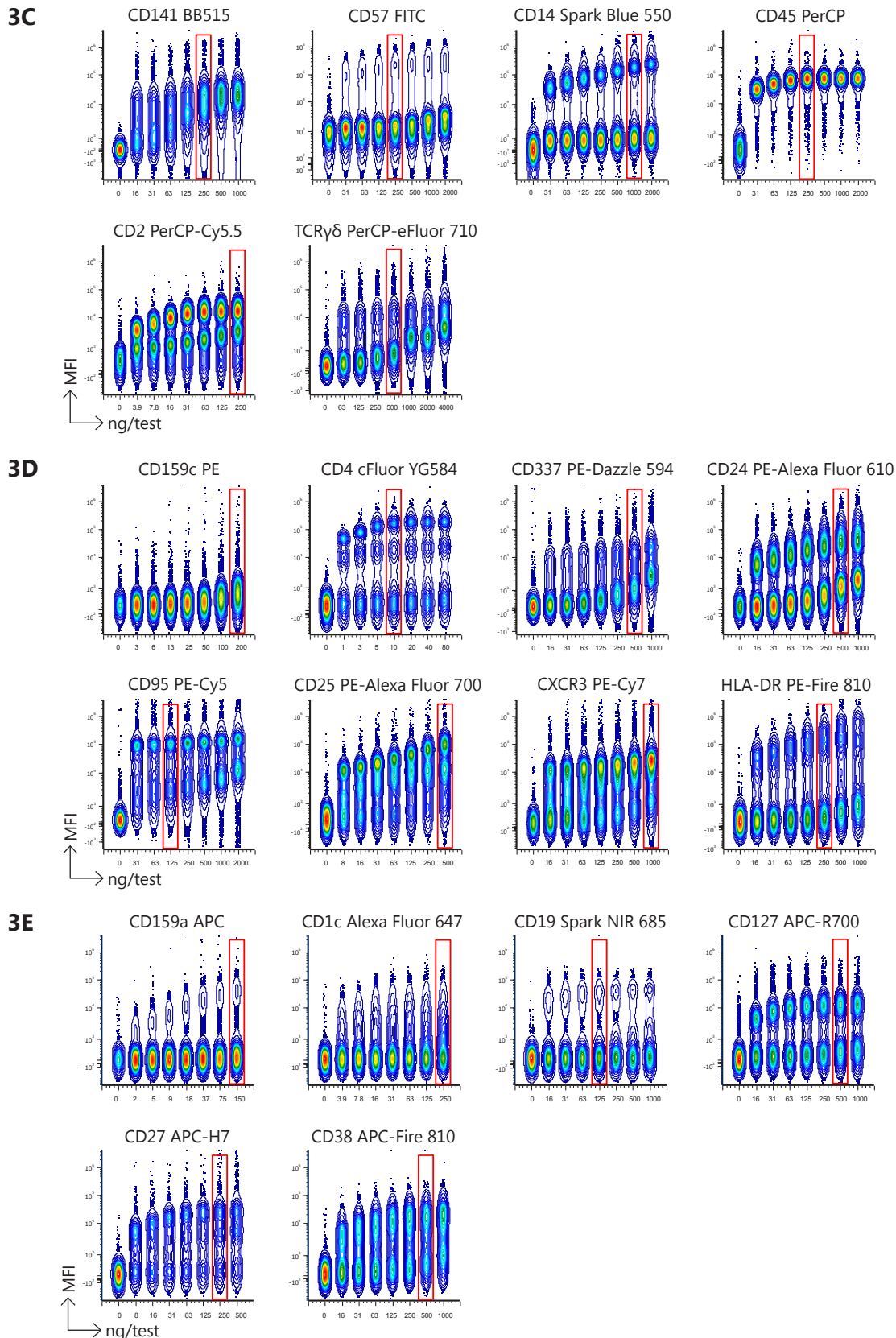

Supplemental Figure 3. Antibody Reagent Titrations

Optimal concentrations of all antibodies were determined through titration experiments. Two-fold dilutions of antibodies were tested. For antibodies that came bottled for use at 5 μ l/test, a range from 10 μ l to 0.15 μ l/test was tested, while concentrations from 1 μ g to 15 ng/test was tested for antibodies that came bottled at a concentration in μ g/ml. Files were concatenated for analysis using FCS Express version 7 (De Novo Software). Titrations for reagents primarily excited by the UV laser (355 nm) (A), violet laser (405 nm) (B), blue laser (488 nm) (C), yellow-green laser (561 nm) (D), and red laser (640 nm) (E) are shown. Final titration results are expressed as ng/test (see [Supplemental Table 4](#)).

4A

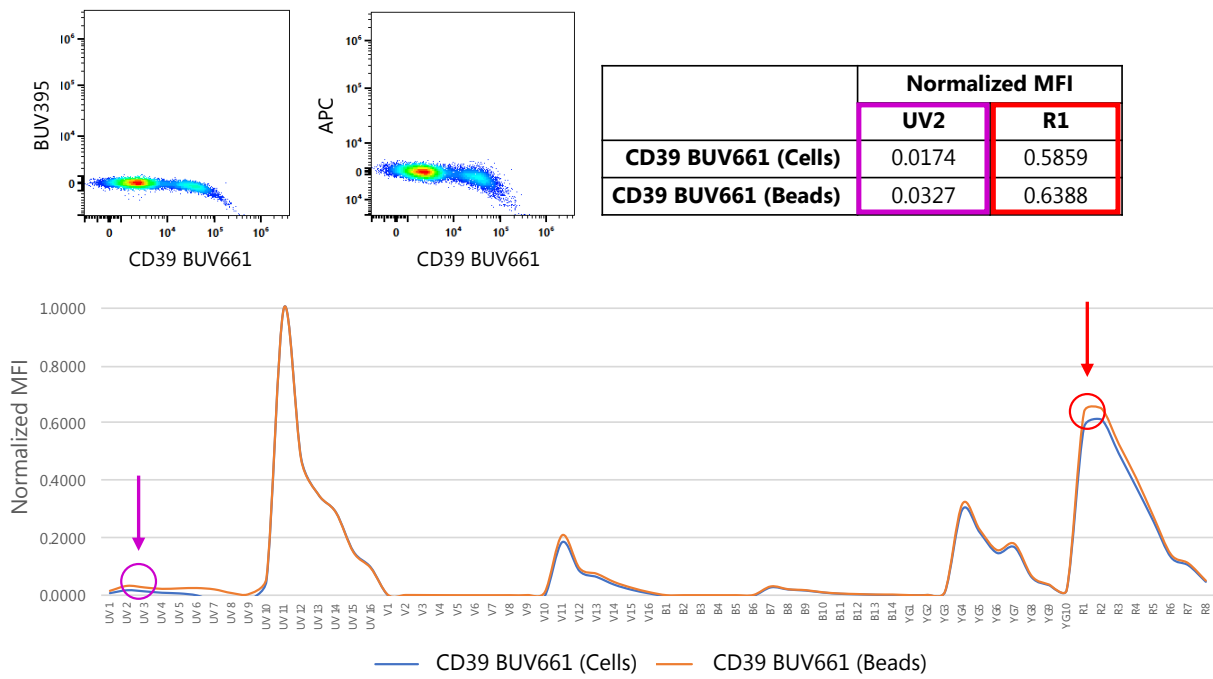

4B

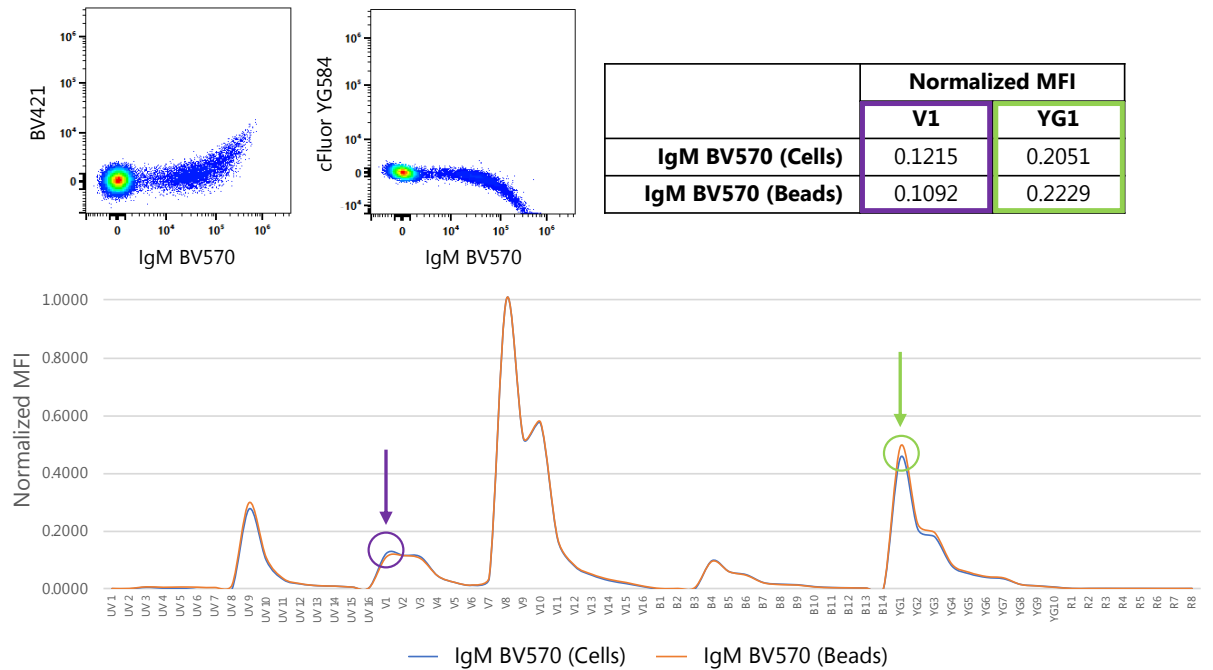

Supplemental Figure 4. Examples of Unmixing Errors Using Beads vs. Cells as Reference Controls

In evaluating the unmixing outcome when using beads vs. cells as reference controls, several fluorochromes were identified for which the use of beads led to unmixing inaccuracies. These unmixing inaccuracies were the result of minor differences in the spectra of fluorochromes when the same antibody was bound to beads vs. cells. (A) When CD39 BUV661 bound beads were used to unmix CD39 BUV661 single stained cells, unmixing inaccuracies were observed in BUV395 (peak channel UV2) and APC (peak channel R1). The normalized overlay demonstrates where differences in the spectra were observed between the two reference control materials (beads vs. cells). The box in the upper right shows the normalized MFIs for the two channels where the differences are highlighted (colored circles and arrows). (B) IgM BV570 bound beads, used to unmix IgM BV570 SS cells, resulted in inaccurate unmixing in BV421 (peak channel V1) and cFluor YG584 (peak channel YG1). The normalized overlay demonstrates where differences in the spectra were observed between the two reference control materials (beads vs. cells). The box in the upper right shows the normalized MFIs of the two channels where the differences are highlighted (colored circles and arrows).

Step 3: Unmixing Accuracy of the MC Tube

Data was unmixed using the SpectroFlo software v2.2 using an ordinary least squares algorithm. To check that the unmixing of the MC tube was accurate, data was cleaned up (singlets, live, scatter gate, aggregate exclusion if needed) and NxN plot permutations were screened ([Supplemental Figure 5](#)). For most of the markers, unmixing was very accurate ([Supplemental Figure 5A](#)). Errors were only visually identified in 16 of the 1560 combinations. An example of the errors that were encountered is presented in [Supplemental Figure 5B](#). Corrections were applied only when the errors were observed between fluorochromes that had spillover between them and when the authors had solid knowledge of the expected expression pattern. The correction was estimated visually to align the median of the negative and positive populations in the y-dimension. The maximum correction that had to be applied was 2.8%, corresponding to BUV737 into BV750. Of note, these corrections did not have an impact on the outcome of the analysis, either manual or unsupervised.

Step 4: SS Control vs. MC Resolution for Each Marker ([Supplemental Figure 6A-B](#))

After unmixing accuracy was checked, the resolution of every marker in the panel was checked by comparing the SS control tube to the same marker in the MC sample. Three different scenarios were observed:

1. Resolution was identical, and no action was needed.
2. The positive population in the MC tube was dimmer. In this case the titer was adjusted ([Supplemental Figure 6B](#)), and the staining protocol was evaluated for any possible staining optimization (see [step 6 below](#) and [Supplemental Figure 9B](#)).
3. The negative population in the MC tube was significantly wider, resulting in lower population resolution (lower stain index). In this case, data was gated according to the population gating hierarchy and evaluated for any compromise in resolving the population of interest. In all cases it was determined that the introduction of spread for a given marker did not negatively impact the overall performance of the panel.

Step 5: Assessment of Spread Impact on Resolution ([Supplemental Figures 7 and 8](#))

One of the great advantages of full spectrum flow cytometry is the ability to utilize highly overlapping fluorochromes that traditionally could not be used together in conventional flow cytometers. This capability was critical for the development of a 40-color panel. However, highly overlapping fluorochromes are known to exhibit increased spread into other fluorochromes, which could impact resolution quality. For highly overlapping fluorochromes where significant spread was anticipated, visual inspection of those combinations and impact of the spread were evaluated ([Supplemental Figure 7](#)). In general, based on good panel design practices, these occurred in combinations of markers that are not co-expressed and therefore did not have a substantive negative impact.

FMO controls were used to guide and/or assess positive and negative delineations ([Supplemental Figure 8A](#)). FMOs were run for the following markers with low level of expression: CD25, CXCR5, CCR5, CCR6, and PD-1. For each of the main cellular subsets (monocytes, TCR $\gamma\delta^+$, CD3 $^+$, CD4 $^+$, CD8 $^+$, CD3 $^+$ CD56 $^+$, CD19 $^+$ CD20 $^+$, and CD3 $^-$ CD56 $^+$), gates to identify positive events for these markers were set based on the FMO control (lower row for each marker) and applied to the MC samples (upper row for each marker). For all the markers evaluated, identification of positive events was straightforward.

In addition, the impact of spread on population resolution was evaluated by comparing the MC samples with FMOs of the highly overlapping dye ([Supplemental Figure 8B](#)). FMOs for BB515, FITC, PE-Alexa Fluor 610, and Spark NIR 685 were run to assess the impact of spread introduced by these fluorochromes into fluorochromes with a high similarity. BB515 and FITC were chosen because these dyes had the highest values in the SSM matrix. PE-Alexa Fluor 610 and Spark NIR 685 were chosen because, prior to this panel, there was no experience using them in combination with PE-Dazzle 594 and Alexa Fluor 647, respectively. Plots on the left show the population resolution in the MC sample while plots on the right show the resolution of the same population in the indicated FMO control. When differences in spread of the negative population were observed, a bar measuring the spread was added to each plot to facilitate visual comparison. To assess the impact of spread from FITC into BB515, lineage negative (Lin $^-$) cells were plotted by HLA-DR vs. CD141 to visualize the resolution of CD141 $^+$ dendritic cells (first row). For BB515 spread into FITC, cells were gated to evaluate CD57 resolution on NK cells (second row). The spread from PE-Alexa Fluor 610 into PE-Dazzle 594 was evaluated by observing the resolution of CD337 on NK cells (third row). Finally, to assess the spread introduced by Spark NIR 685 into Alexa Fluor 647, cells were gated on Lin $^-$ and HLA-DR vs CD1c plotted to represent the impact on resolution of CD1c $^+$ dendritic cells (last row). This analysis demonstrated minimal

5A

CD39 BUV661

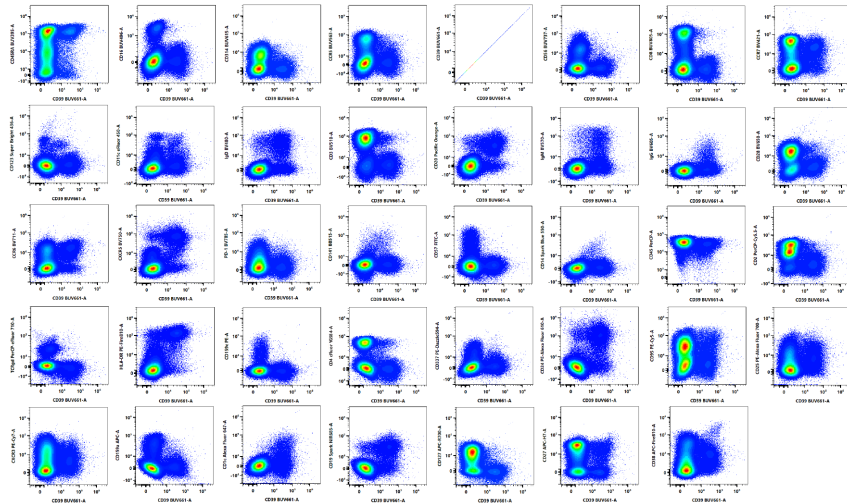

IgM BV570

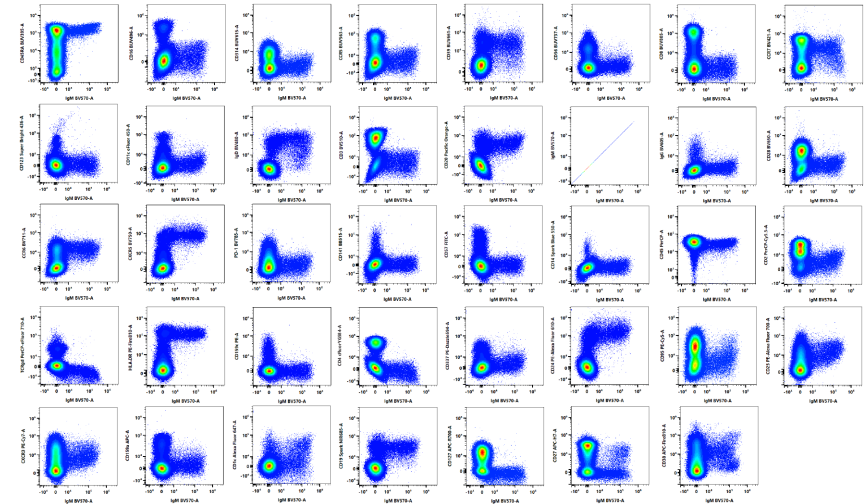

5B

CD56 BUV737

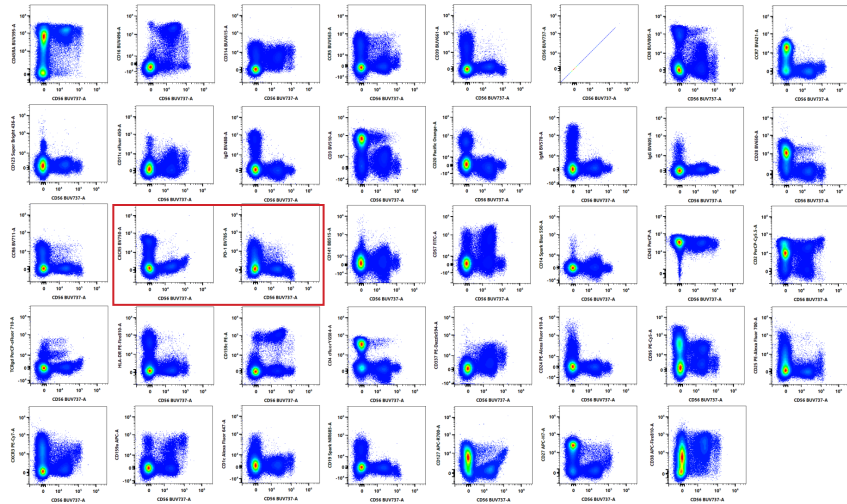

CD56 BUV737, Errors Corrected

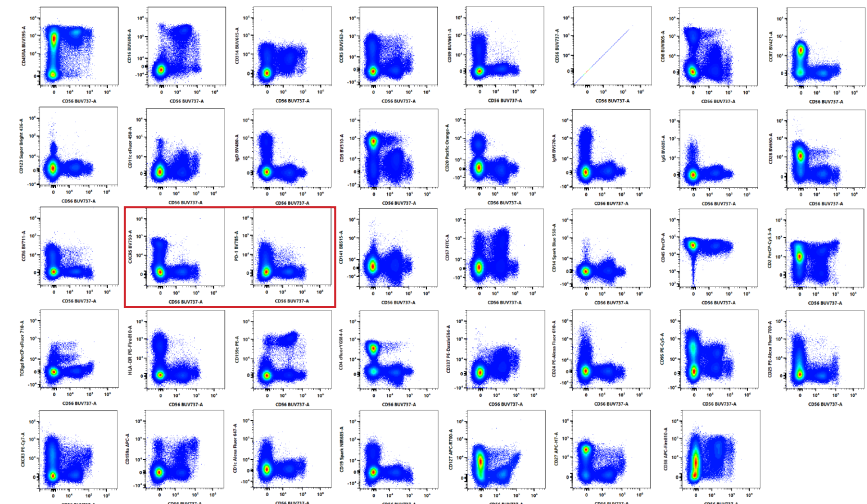

Supplemental Figure 5. QC of Unmixing Accuracy of MC Stained Sample

For the MC samples, NxN plots were generated to visually assess the unmixing accuracy. Data plotted for evaluation was gated on singlets, scatter, live, and non-aggregates. (A) Two representative examples where unmixing was accurate are presented; CD39 BUV661 and IgM BV570. The plots presented are based on the data from [Supplemental Figure 4](#). In each of the presented NxN plots, the same marker is plotted on the x-axis (CD39 BUV661 on the left and IgM BV570 on the right) and the y-axes represent every other fluorochrome in the panel. When unmixing was performed using SS cells as reference controls, no significant unmixing inaccuracies were observed. (B) Unmixing errors were observed in a minority of combinations (16 in the 40x40 matrix). A representative example of an error observed in the unmixing accuracy of CD56 BUV737 is presented (left panel, red box), namely into BV750 and BV785. Minimal corrections were required to align the negative and positive populations (right panel, red box): 2.8% into BV750 and -1% into BV785.

6A

LEGEND

- Single Stained
- Multicolor

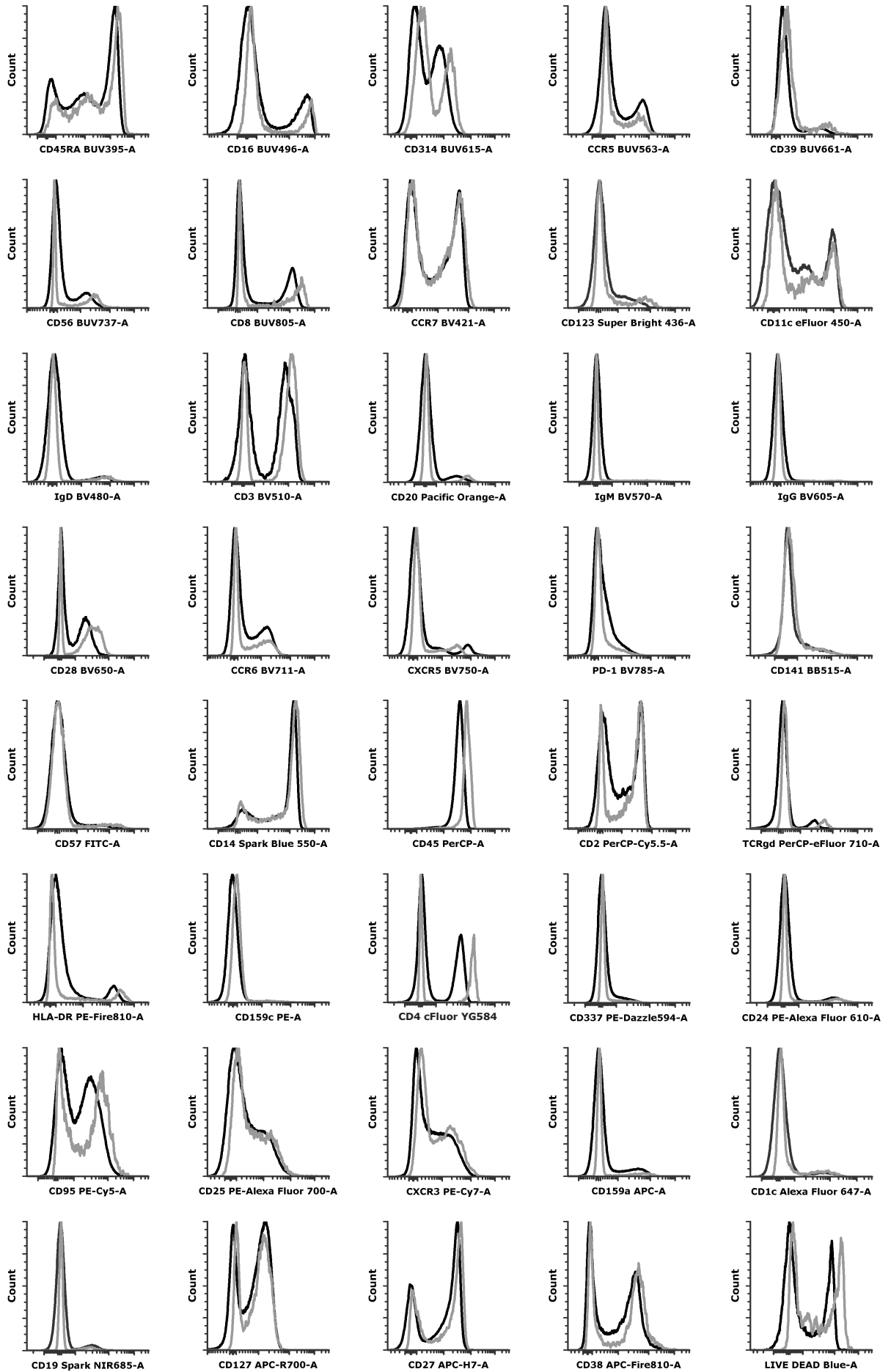

6B

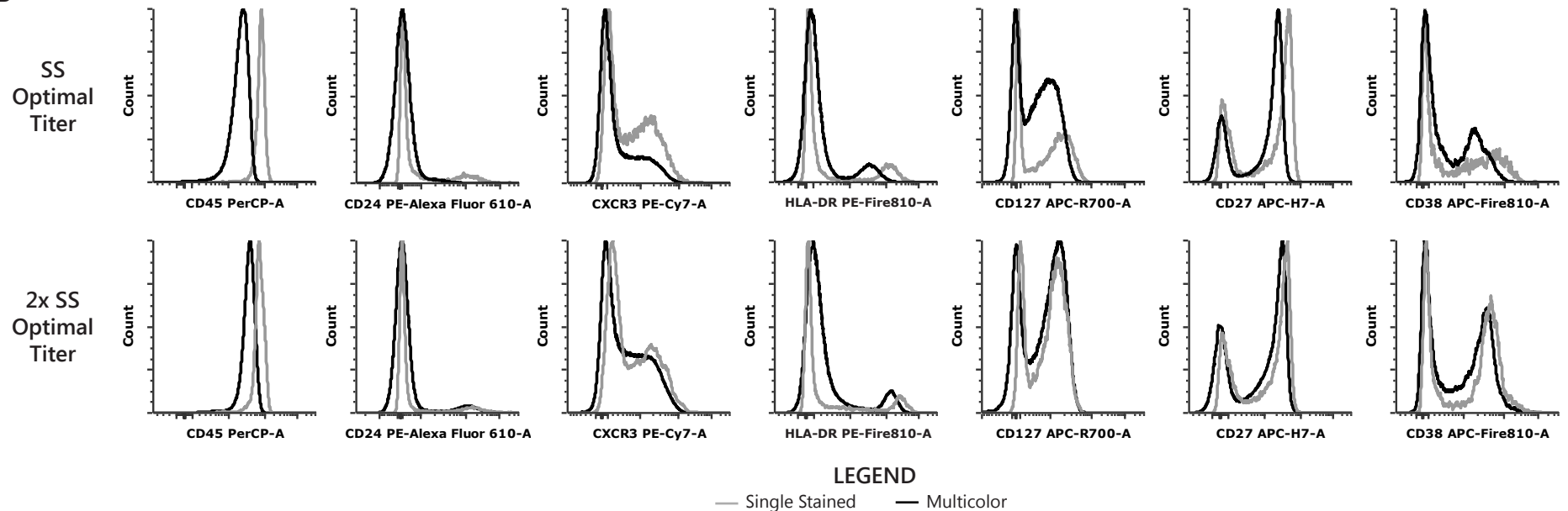

Supplemental Figure 6. Staining Resolution: SS vs. MC Samples

As part of the panel optimization, each marker in the MC stained samples was evaluated to determine whether an optimal resolution was maintained. To assess this, staining patterns were compared between the SS controls and the MC sample using PBMCs from the same donor. (A) For both SS (gray line) and MC (black line) samples, the data in the overlays were gated on singlets and, depending on the marker, lymphocyte or monocyte scatter gates. (B) In cases where this assessment identified reduced resolution in the MC samples for a given marker due to lower intensity of the positive signal (top row), antibody concentrations were increased by one titer point to get as close as possible to the resolution obtained in the SS tube (bottom row). Note that in those cases, doubling the titer in the MC tube increased the brightness of the positive population and had no impact on the negative population (no shifts were observed), resulting in increased resolution.

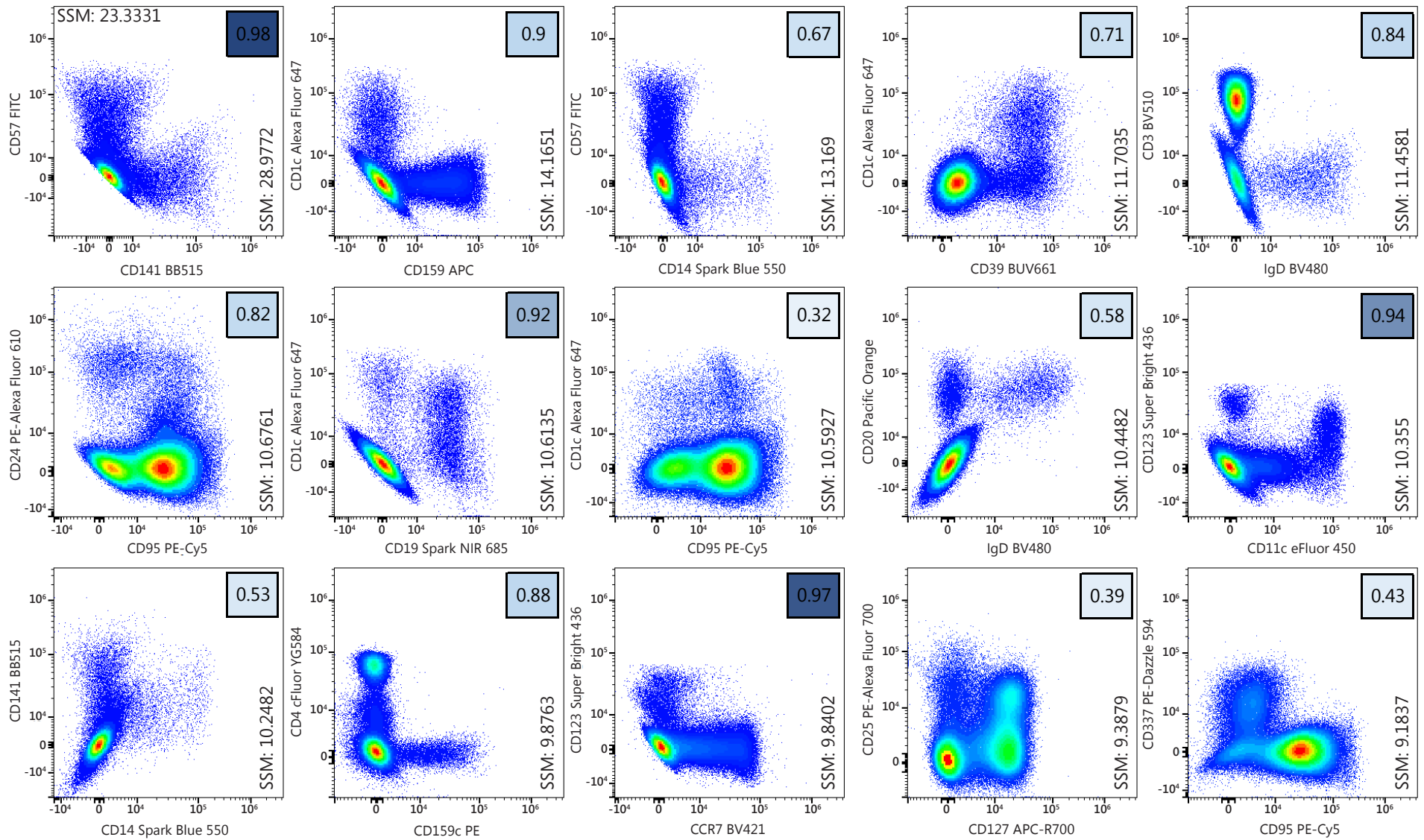

Supplemental Figure 7. Assessment of Highly Overlapping Fluorochromes

The impact of spread introduced by using highly overlapping fluorochromes was assessed using the MC sample. Fluorochrome combinations having the 16 highest values in the spillover spread matrix (SSM) ([Supplemental Figure 2D](#)) are presented. Plots are gated on singlets, live, non-aggregates, FSC/ SSC low/ intermediate, and CD45⁺. The fluorochrome on the x-axis introduces spread to the fluorochrome on the y-axis, except for the first plot (BB515 and FITC), as in this case both fluorochromes have a significant spread into each other. SSM values are presented in each plot. Note that the antigens assigned to the pairs with the highest SSM values (FITC and BB515, APC and Alexa Fluor 647, Spark Blue 550 and FITC) have no co-expression. The Similarity Index for each fluorochrome pair is indicated in the box in the upper right hand corner. The highly correlated distributions (diagonals) of the autofluorescent populations in the combinations that have high Similarity Indices is expected behavior for such highly overlapping dyes (2).

8A

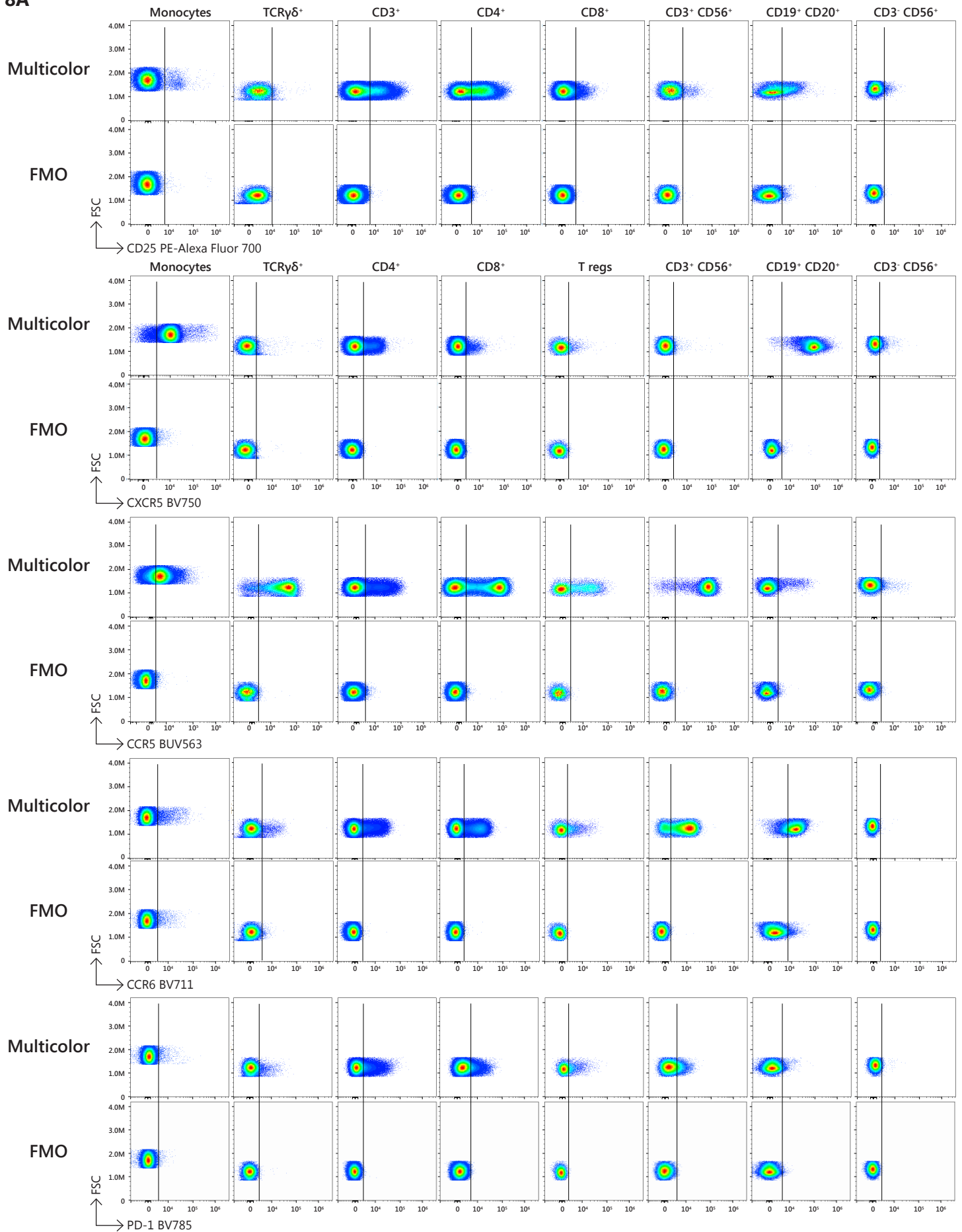

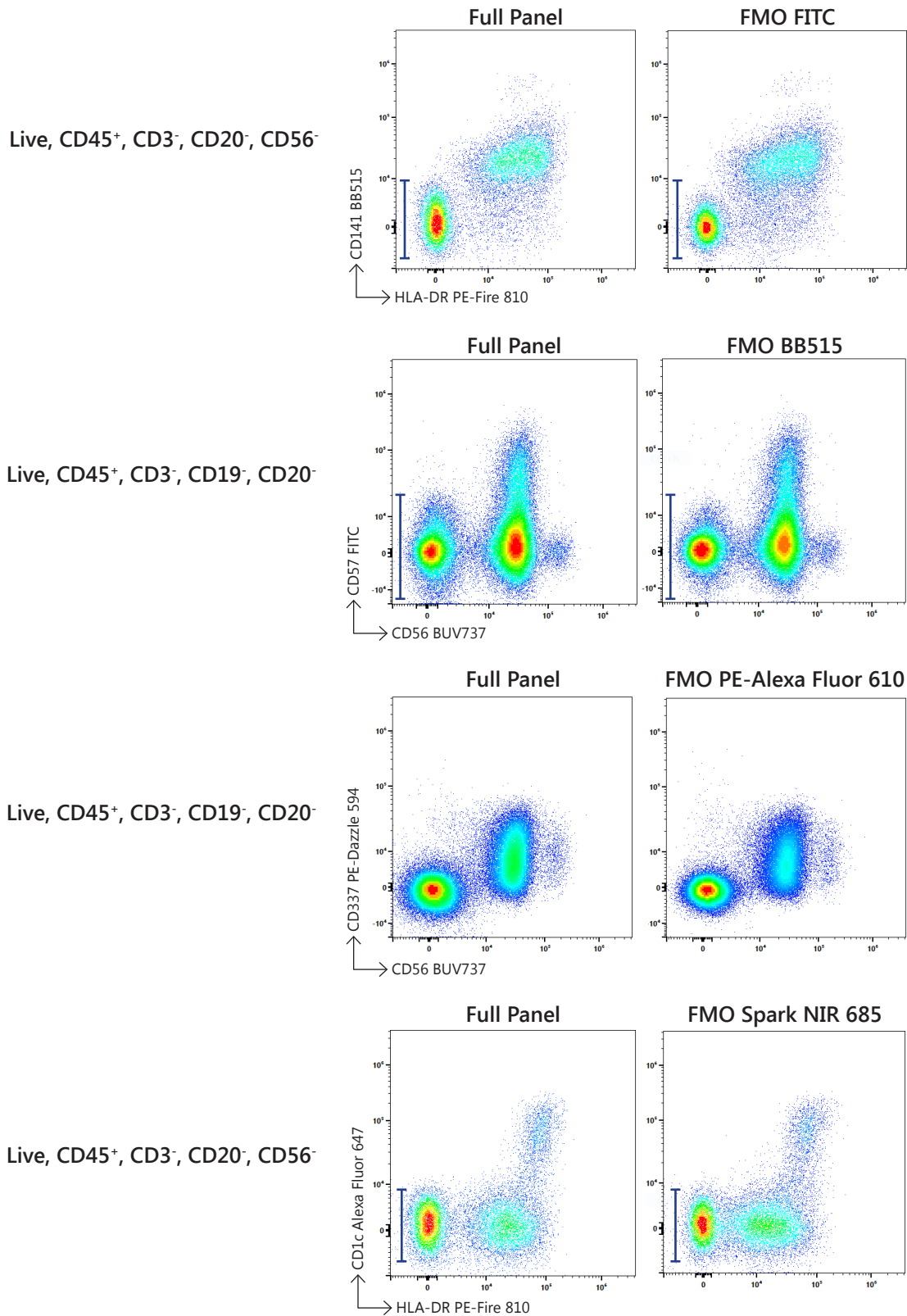

Supplemental Figure 8. Fluorescence Minus One (FMO) Controls

FMOs were used as a quality control for two different purposes: to assess the accuracy in the gating/identification of populations where there was low level expression (A) or to assess the impact of spread in the resolution of a given marker/ population (B). All the markers evaluated with FMOs show clear identification of positive events (A), while minimal spread of the negative populations were observed (black lines). Nearly identical population resolution was achieved with and without the highly overlapping fluorochrome present in the panel (blue bars) (B).

impact on the spread of the negative population and hence no loss of resolution resulting from the use of these highly overlapping dyes.

Step 6: Fine Tuning of Staining Protocol ([Supplemental Figure 9](#))

Based on the results of the above assessments of the panel's performance and other independent observations, several adjustments to the staining protocol were made to further optimize its performance. These adjustments were as follows:

- Titers were adjusted, where deemed necessary, based on SS vs. MC assessment (see [step 4 above](#) and [Supplemental Figure 6B](#)).
- Based on previous reports (8) of interference when multiple chemokine receptors are stained in the same panel, the staining of the chemokine receptors in the panel was optimized. Sequential vs. simultaneous staining was assessed to determine whether any improvements in resolution could be achieved. For some chemokine receptors (CCR5 and CXCR5 on B cells) an improvement was seen, while no differences were noted for CCR6 ([Supplemental Figure 9A](#)).
- Initial staining for TCR $\gamma\delta$ yielded poor resolution of this population. Optimization of TCR $\gamma\delta$ staining was achieved by the addition of the reagent at a different step in the staining process, subsequently improving the identification of this subpopulation of T cells ([Supplemental Figure 9B](#)).
- A significant amount of antibody aggregates were observed during the panel development with CD24 PE-Alexa Fluor 610 and CXCR5 BV750. Centrifugation of these reagents at 10,000 x g for 5 minutes decreased the presence of aggregates.

A summary of the reagents used in the panel, including their final titer, is provided in [Supplemental Table 4](#).

DATA ANALYSIS

Manual gating of the main populations is displayed in Figure 1A. Detailed immunophenotyping of each cellular subset is presented in [Supplemental Figure 10](#). While this display is commonly used to demonstrate the ability to resolve populations based on traditional gating strategies, manual data analysis of a 40-color panel is generally not practical as it is very time consuming, suffers from individual user bias, and compromises the ability to characterize subsets in multiple dimensions (9-11). Dimensionality reduction techniques for exploratory data analysis, such as Uniform Manifold Approximation and Projection (UMAP), have been used for mass cytometry data and single cell RNA-seq (12). These techniques can also be applied to fluorescent high-dimensional datasets, given that appropriate QC is performed prior to performing this kind of analysis.

Data from OMIP-069 were analyzed with the OMIQ platform (<https://www.omiq.ai/>, Figures 1B, and [Supplemental Figure 11](#)) utilizing the following pipeline. First, the scaling was adjusted to ensure greater than 99% of events were on scale for each channel and the negative population was unimodal around 0. The data were manually gated to remove aggregates, dead cells, debris, and CD45 negative events, and then the data were sub-sampled to include 400,000 CD45+ live singlets from each sample. Next, flowCut (13) was run to check for any aberrant regions of the file. FlowCut settings were as follows: all files used, all fluorescent channels and time selected, Segment = 500, Max Contin = 0.15, Mean of Means = 0.13, Max of Means = 0.15, Max of Valley Height = 0.15, Max Percent to Cut = 0.3, Low Density Removal = 0.1, no Gate Line set, Max Channel for Mean Range = 1, Max Channel for Mean SD = 2, no Flagged Rerun, Uniform of Time Check = 0.22, Remove Multi SD = 7. Results were as follows: largest continuous jump = 0.095, largest mean of % of range of means divided by range of data = 0.084, Max of % of range of means divided by range of data = 0.118, no events removed). Subsequently, a UMAP (14) analysis was performed to visualize the different sub-populations in groups. UMAP settings were as follows: all files used, all fluorescent parameters were used besides CD45 and Live/Dead, Neighbors = 80, Minimum Distance = 0.7, Components = 2, Metric = Euclidean, Learning Rate = 1, Epochs = 250, Random Seed = 9346, Embedding Initialization = spectral. Following the UMAP analysis, FlowSOM (15) was run to cluster the data. FlowSOM settings were as follows: all files used, clustering features CD4, CD8, CD45RA, CCR7, CD25, CD127, CD27, CD28, TCR $\gamma\delta$, CD16, CD1c, CD11c, IgD, IgM, and IgG, umap_1, umap_2, 625 clusters with xdim = 25 and ydim = 25, rlen = 10, Distance Metric = euclidian, consensus metaclustering with k = 100, Random Seed = 1337. After the FlowSOM analysis, the metaclusters were grouped into commonly recognized biological populations if possible. A heatmap was generated with the resulting populations and clustered hierarchically on all surface markers with a euclidean distance metric to indicate the similarity of the populations. This pipeline allows the FlowSOM clusters to be verified and translated into well-recognized populations via the heatmap, then those populations can be visualized on the UMAP parameters for ease of comparison between samples.

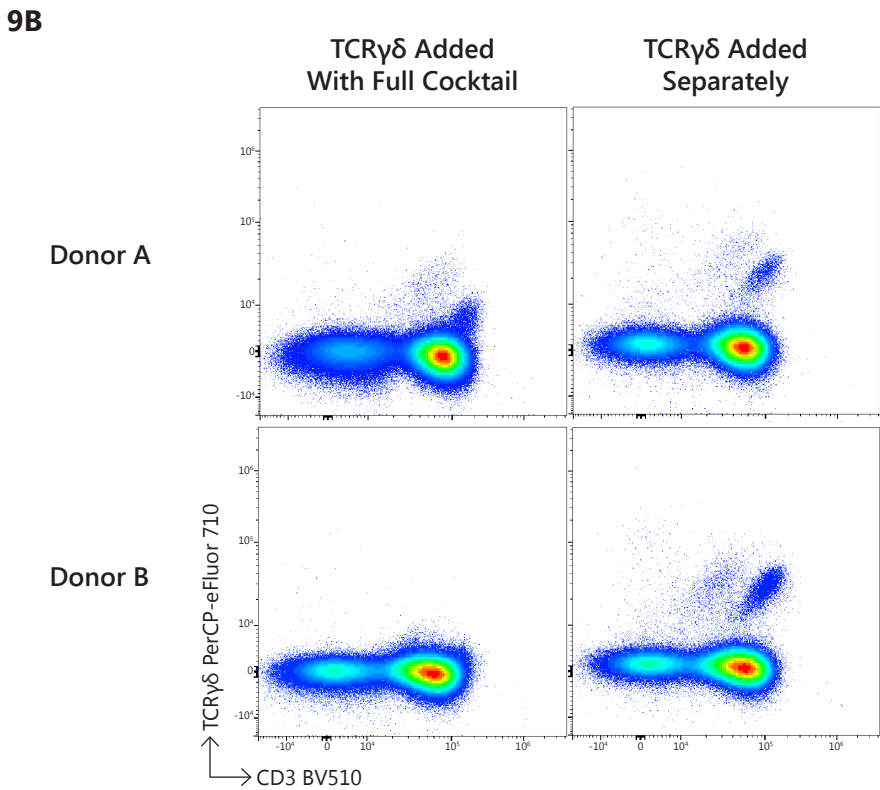
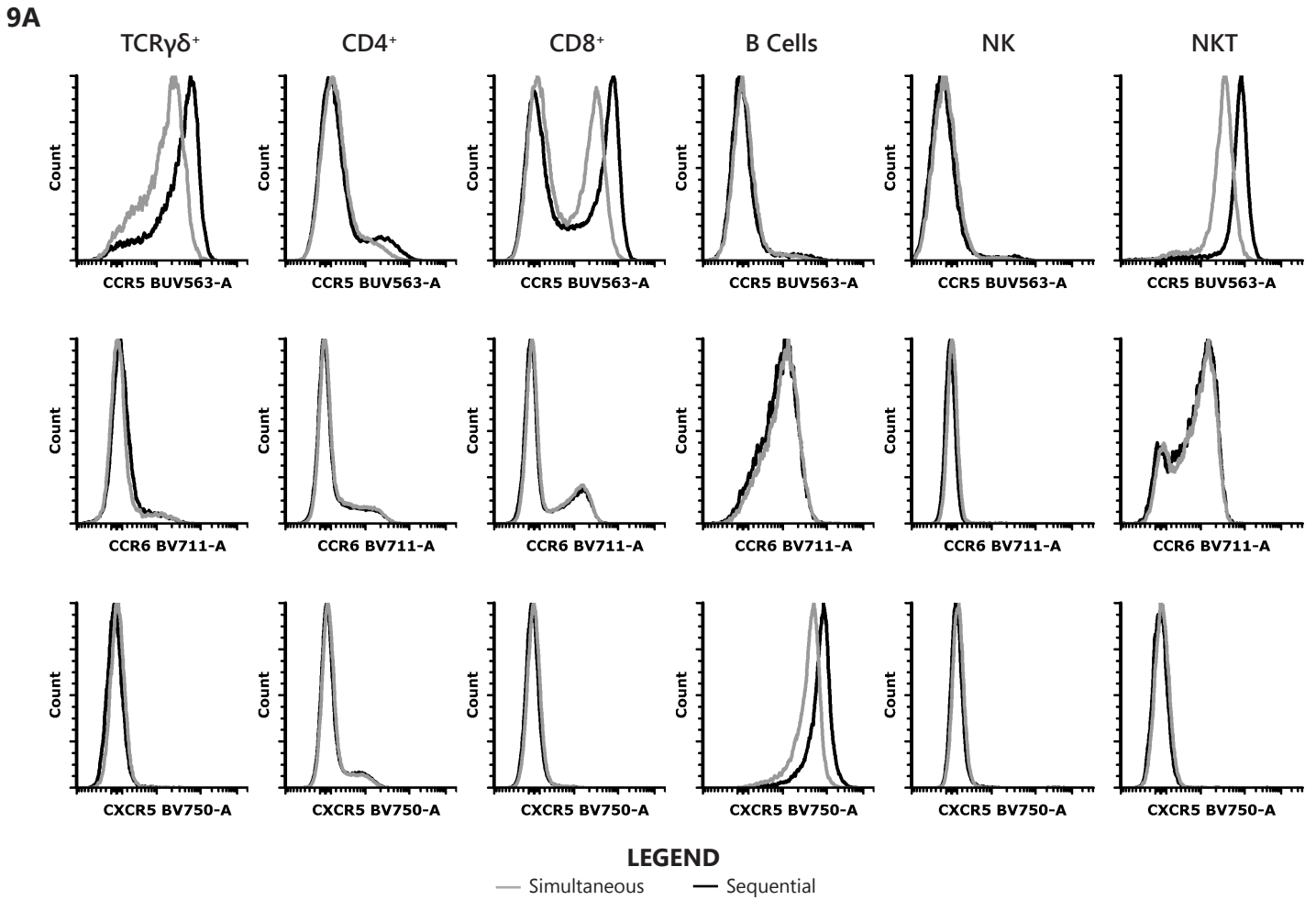

Supplemental Figure 9. Effects of Staining Conditions on Staining Quality

Optimization of the staining protocol was performed to improve the resolution of populations of interest. **(A)** Staining protocols were compared by overlaying MC cells stained simultaneously (gray line) or sequentially (black line) with chemokine receptor antibodies to determine differences in staining quality for these reagents. Indicated subpopulations were used to verify performance across multiple cell types. **(B)** Improvements in staining quality of TCR $\gamma\delta^+$ cells: comparison of resolution when antibody was added as part of the full cocktail (left) or added separately (right). Data from two different donors is presented.

SPECIFICITY	FLUOROCHROME	CLONE	CATALOG #	VENDOR	Titer (ng/test)
Viability	LIVE/DEAD Blue	-	L34962	Thermo Fisher	5 μ L of 1:40 dilution of stock
CD45	PerCP	2D1	368506	BioLegend	250
CD3	BV510	SK7	344828	BioLegend	400
CD4	cFluor YG584	SK3	R7-20041-100T	CYTEK	10
CD8	BUV805	SK1	612889	BD Biosciences	125
CD25	PE-Alexa Fluor 700	CD25-3G10	MHCD2524	Thermo Fisher	500
PD-1	BV785	EH12.2H7	329930	BioLegend	500
TCR γ δ	PerCP-eFluor 710	B1.1	46-9959-42	Thermo Fisher	500
CD14	Spark Blue 550	63D3	367148	BioLegend	1000
CD16	BUV496	3G8	612944	BD Biosciences	250
CD11c	eFluor 450	3.9	48-0116-42	Thermo Fisher	500
CD19	Spark NIR 685	H1B19	302270	BioLegend	125
CD20	Pacific Orange	HI47	MHCD2030	Thermo Fisher	1000
CD24	PE-Alexa Fluor 610	SN3	MHCD2422	Thermo Fisher	500
CD39	BUV661	TU66	749967	BD Biosciences	1000
IgD	BV480	IA6-2	566138	BD Biosciences	125
IgG	BV605	G18-145	563246	BD Biosciences	125
IgM	BV570	MHM-88	314517	BioLegend	312.5
CD141	BB515	1A4	566017	BD Biosciences	250
CD1c	Alexa Fluor 647	L161	331510	BioLegend	250
CD123	Super Bright 436	6H6	62-1239-42	Thermo Fisher	125
CD2	PerCP-Cy5.5	TS1/8	309226	BioLegend	250
CD56	BUV737	NCAM16.2	564447	BD Biosciences	31.25
CCR7	BV421	G043H7	353208	BioLegend	700
CD27	APC-H7	M-T271	560222	BD Biosciences	250
CD45RA	BUV395	5H9	740315	BD Biosciences	250
CD95	PE-Cy5	DX2	305610	BioLegend	125
CD127	APC-R700	HIL-7R-M21	565185	BD Biosciences	500
CD337	PE-Dazzle 594	P30-15	325231	BioLegend	500
CCR6	BV711	G034E3	353436	BioLegend	125
CCR5	BUV563	2D7/CCR5	741401	BD Biosciences	500
CXCR5	BV750	RF8B2	747111	BD Biosciences	250
CXCR3	PE-Cy7	G025H7	353720	BioLegend	1000
HLA-DR	PE-Fire 810	L243	custom*	BioLegend	250
CD38	APC-Fire 810	HIT2	356643	BioLegend	500
CD57	FITC	HNK-1	359604	BioLegend	250
CD28	BV650	CD28.2	302946	BioLegend	250
CD159a	APC	REA110	130-113-563	Miltenyi	150
CD159c	PE	REA205	130-119-776	Miltenyi	200
CD314	BUV615	1D11	751232	BD Biosciences	1000

* Custom conjugation is available through BioLegend

Supplemental Table 4. Final Selection of Reagents Used in OMIP-069

Staining reagents used in the final panel with antibody clone, manufacturer information, and final concentrations used in the staining protocol provided.

OMIP-069: 40 Color Deep Immune Profiling

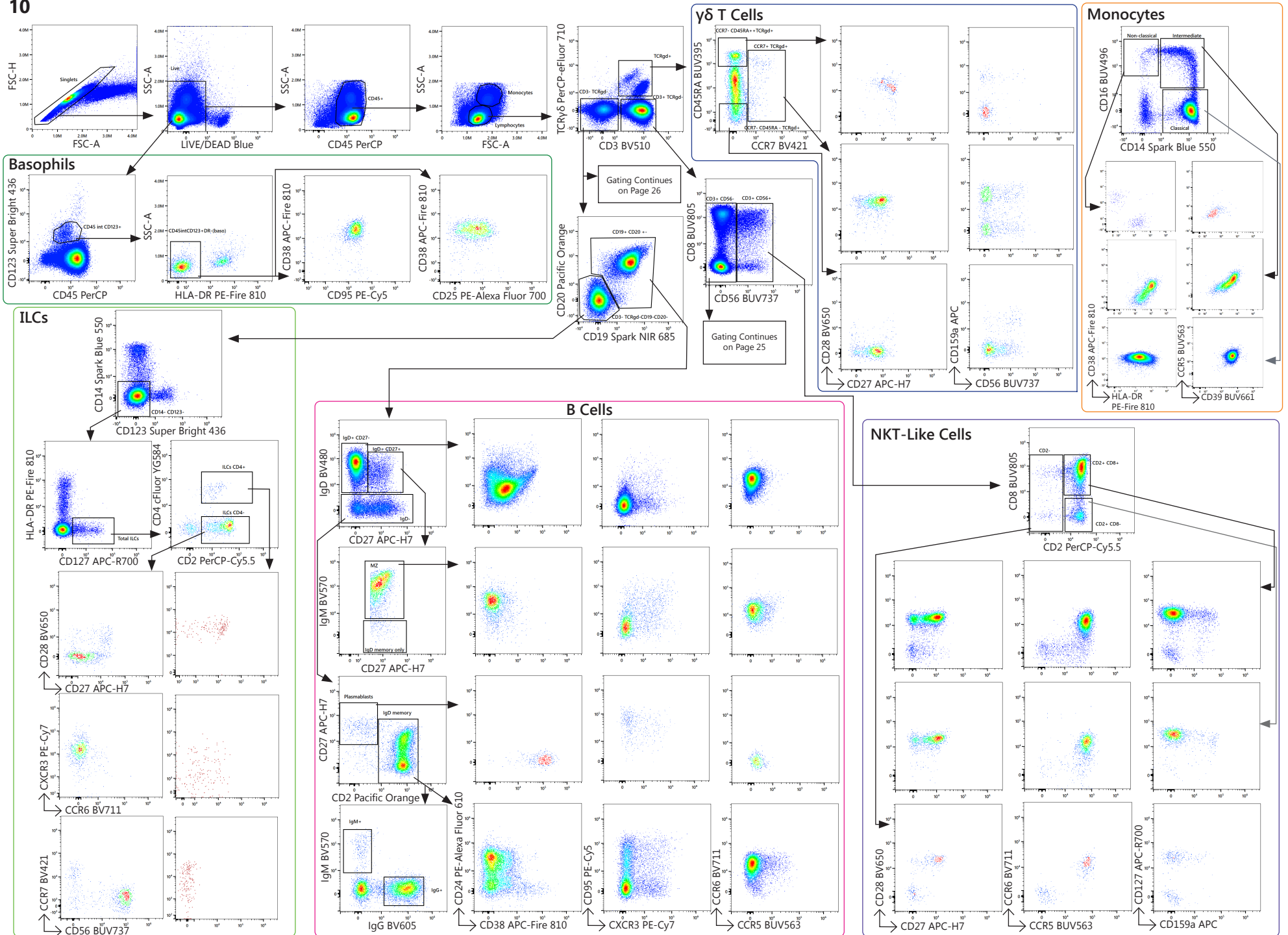

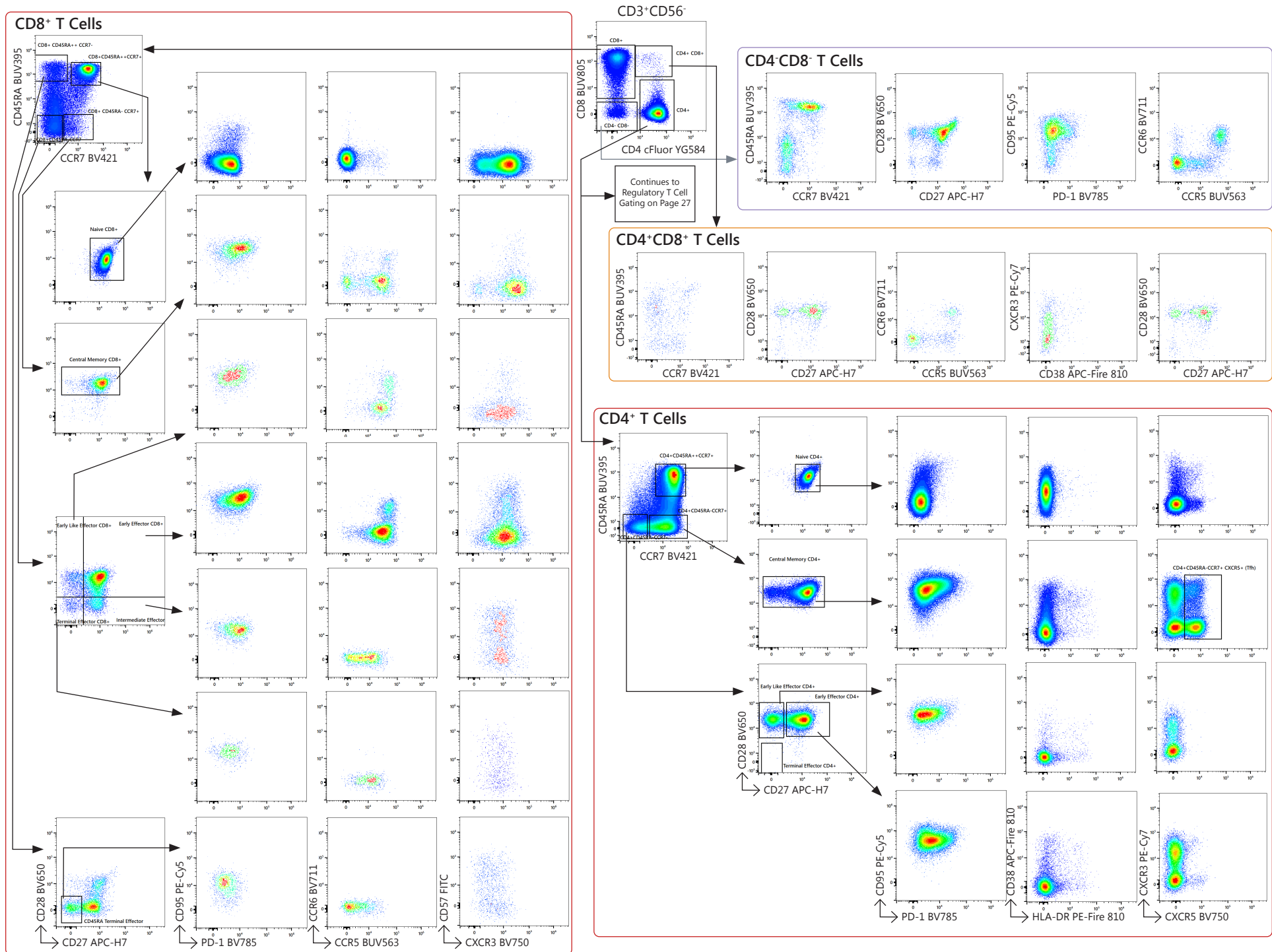

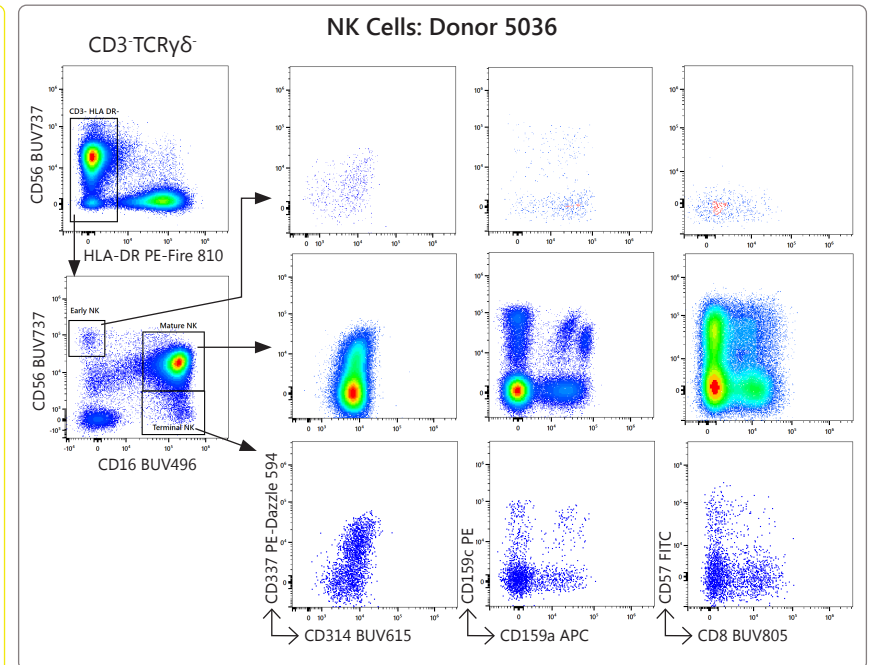
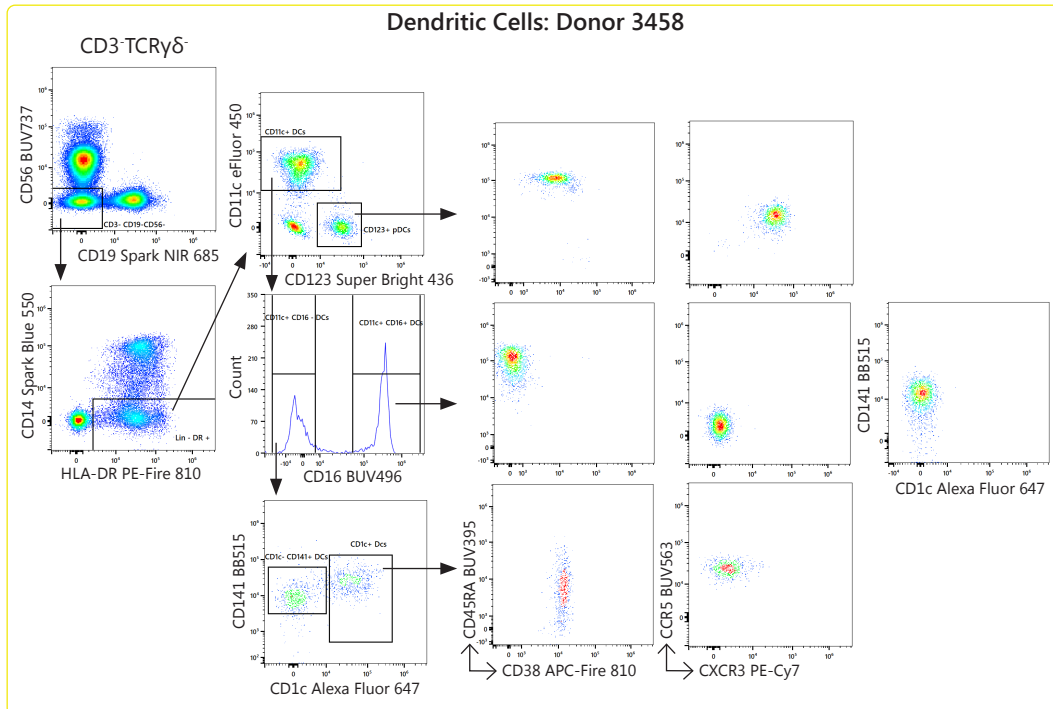
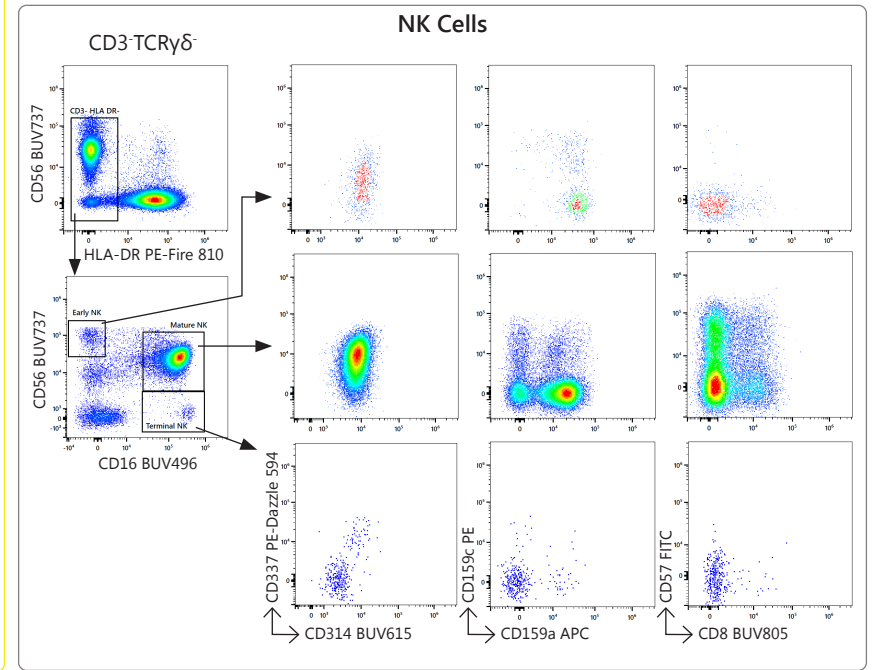
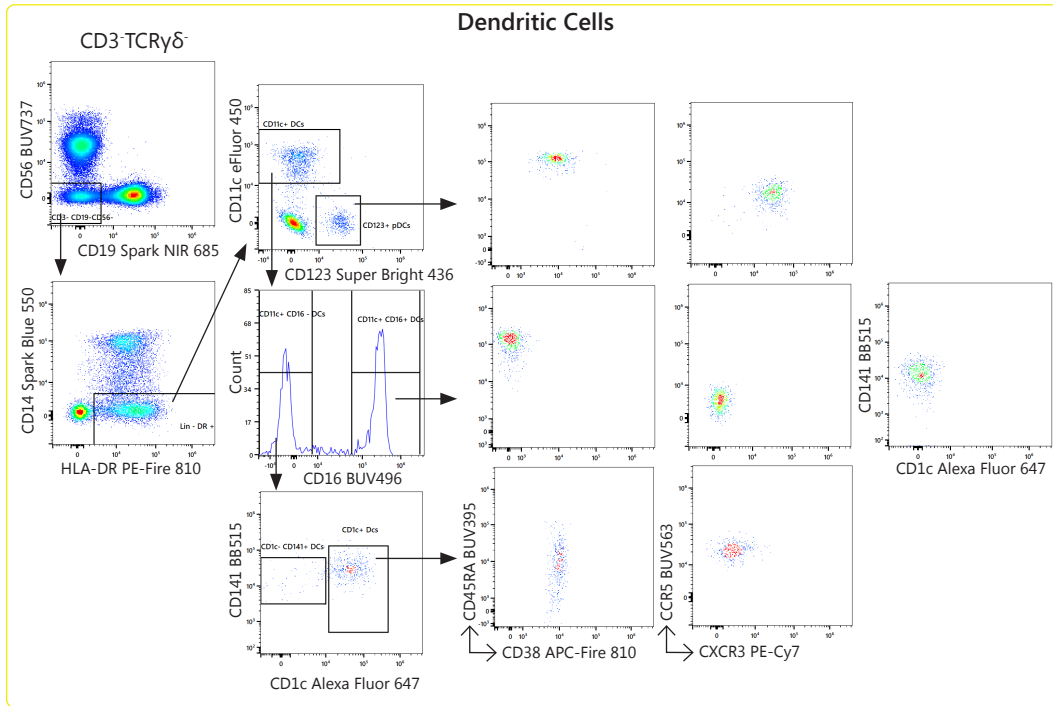

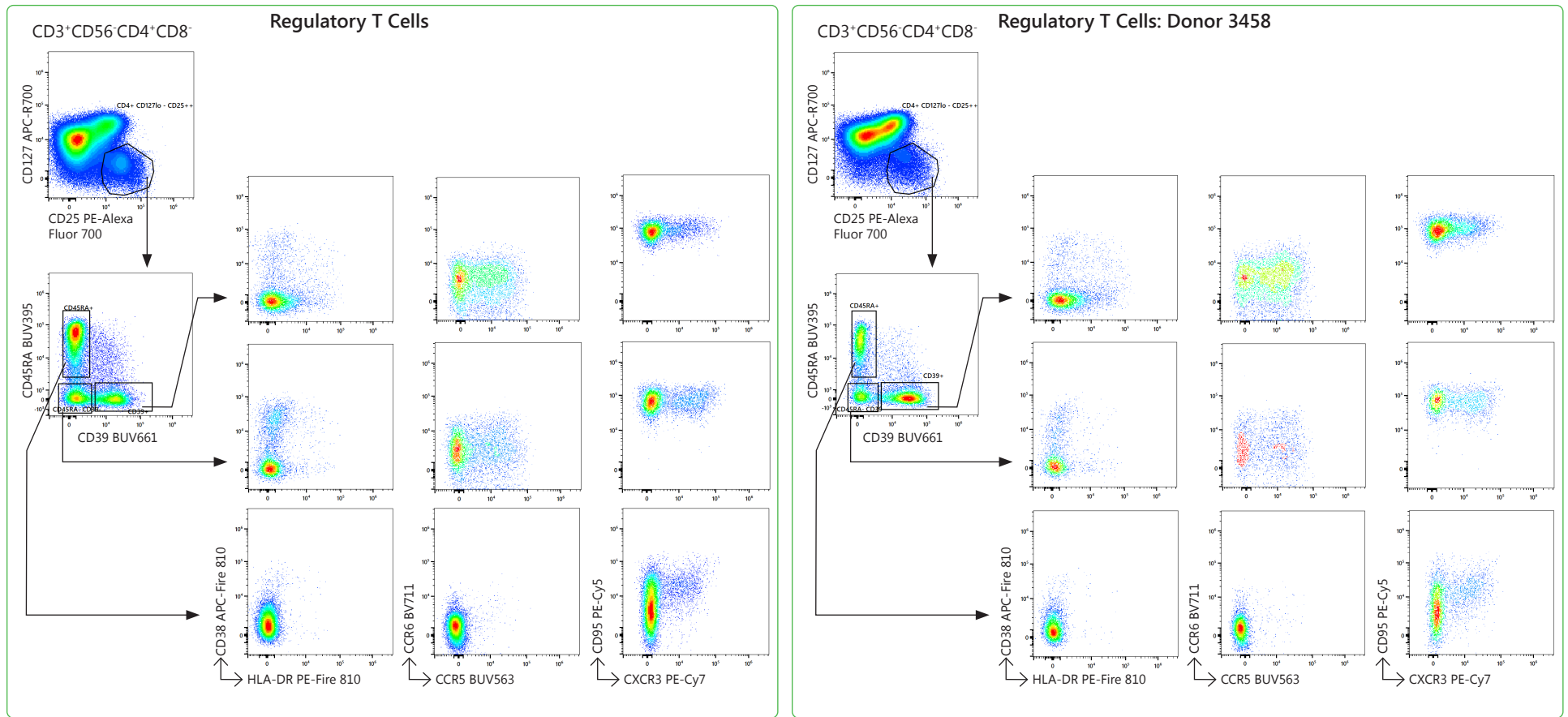

Supplemental Figure 10. Deep Immunophenotyping of All Cellular Subsets

Following the gating scheme presented in Figure 1A, the different cellular subsets were further characterized by manual gating. For each main population, the main markers that showed different levels of expression across the various subsets of that specific population are presented. Data presented corresponds to Donor 4559, as in Figure 1A. For the Tregs, DCs and NK populations, data from an additional donor is presented to illustrate observed difference in level of expression of certain markers.

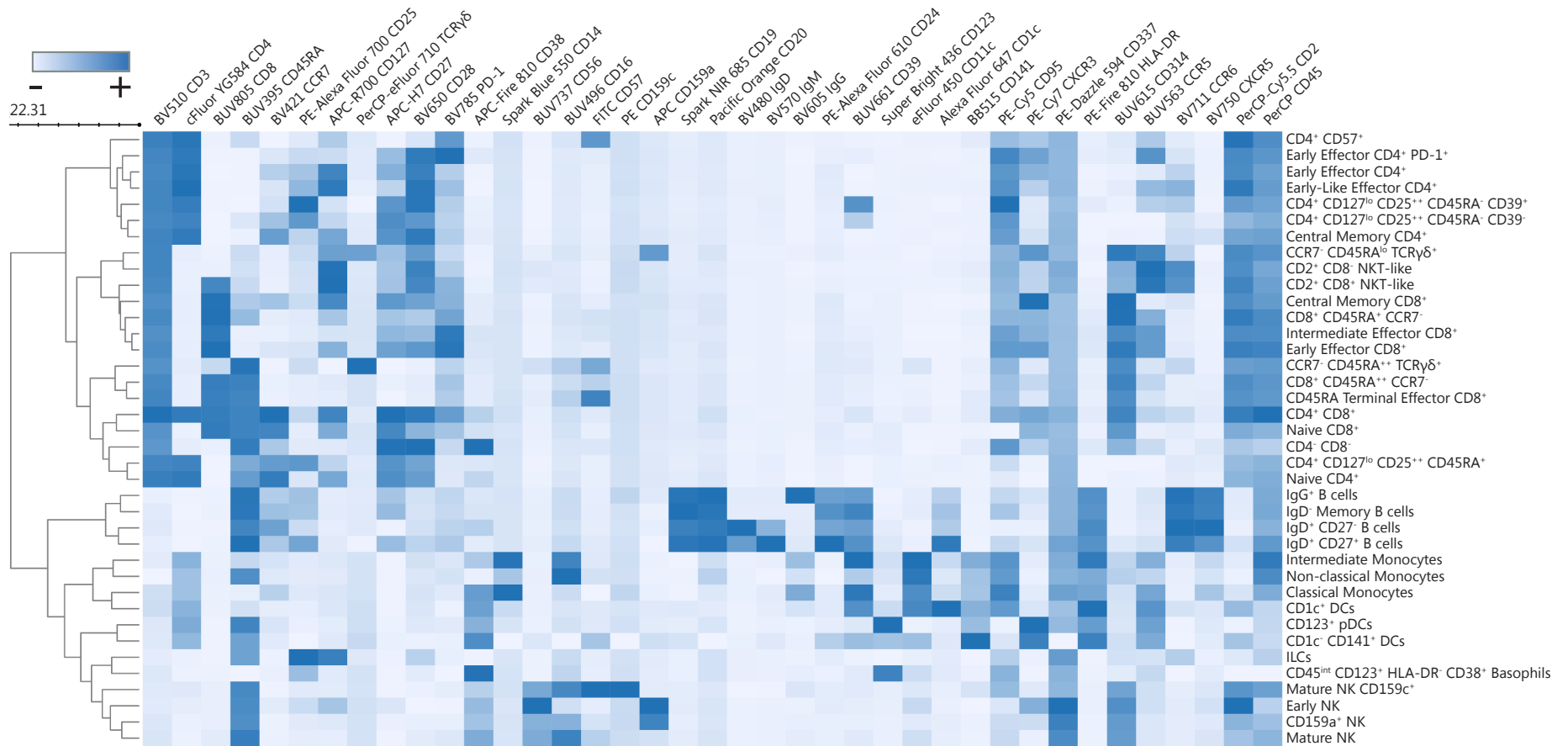

11B

Monocyte & Dendritic Cell Markers

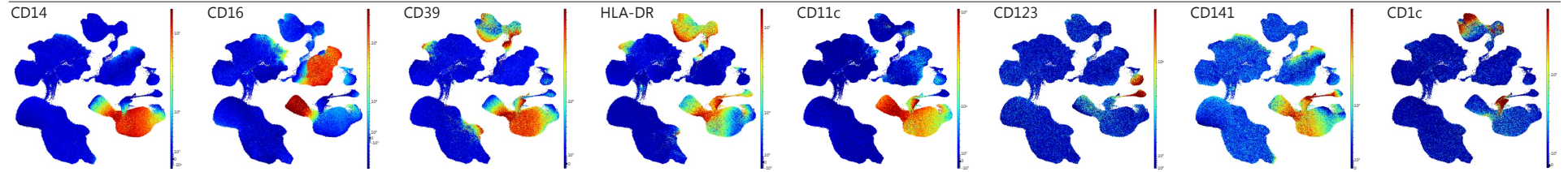

NK & $\gamma\delta$ T Cell Markers

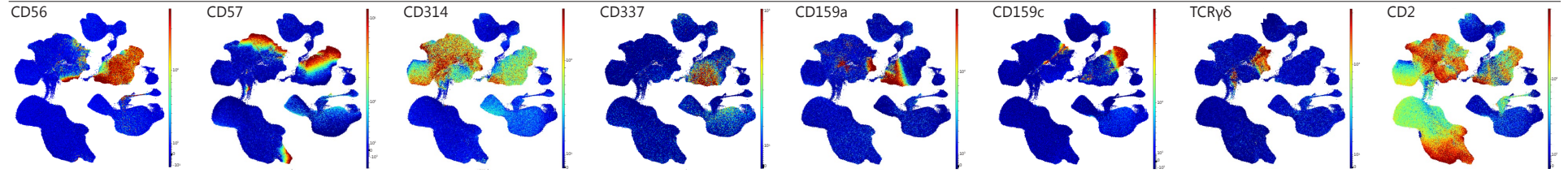

B Cell Markers

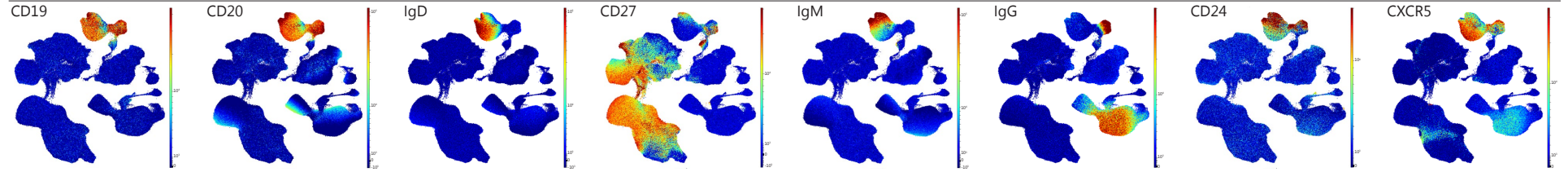

CD4⁺ T Cell Markers

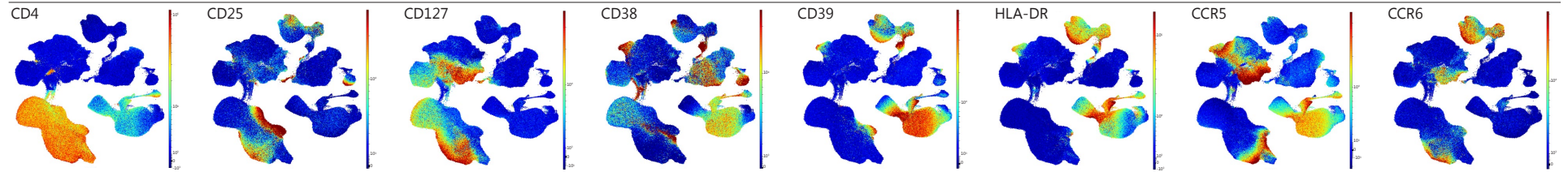

CD8⁺ T Cell Markers

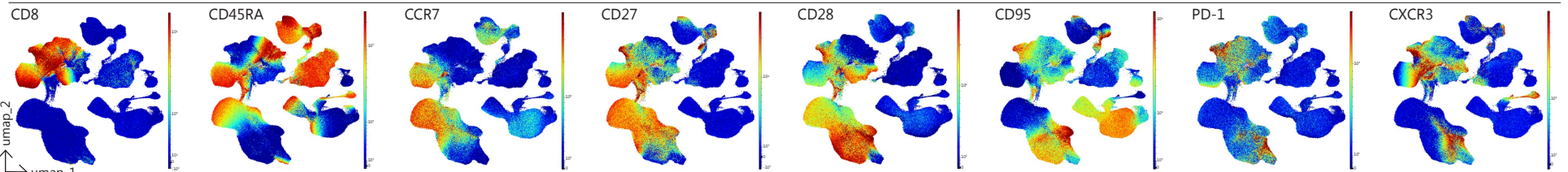

Supplemental Figure 11. High Dimensional Data Reduction of 40-Color Panel

Overview showing the expression of phenotypic markers on PBMCs in several unsupervised analyses. (A) Hierarchically clustered heatmap displaying the marker expressions of manually labeled FlowSOM clusters from four concatenated samples. The marker expression intensity is displayed on a scale from white (negative) to blue (positive). Each column's max and min are mapped to this scale so the values change between markers, consequently the scale is labeled with - and + to indicate relative magnitude. (B) Visualization of the phenotypic variation across all PBMC subsets using UMAP. Marker expression intensity is indicated by the scale bar to the right of each plot, where red is high and blue is low.

OMIP-069: 40 Color Deep Immune Profiling

STAINING PROTOCOL

Materials and Reagents

12x75 mm (5 ml) Falcon® FACS tubes: Corning catalog #352063
RPMI: Sigma catalog # R8758
Fetal Bovine Serum (FBS): Gibco catalog #16000-036
Penicillin-Streptomycin: Gibco catalog #15640-055
PBS: Gibco catalog #20012-027
Brilliant Staining buffer: BD Biosciences, catalog #563794
True-Stain Monocyte Blocker™: BioLegend catalog #426101
UltraComp eBeads™ Compensation Beads: Thermo Fisher, catalog #01-2222-41
Wash/Stain Buffer: BD Stain Buffer (BSA) catalog #554657
Antibodies specified in [Supplemental Table 4](#)

Cryopreserved PBMCs were purchased from AllCells (www.allcells.com, California USA). Different donors were used throughout the panel development process.

Prepared buffers: complete RPMI: add 50 ml of FBS, 5 ml of Penicillin-Streptomycin into 500 ml of RPMI 1640 (with L-glutamine and sodium bicarbonate)

Thawing PBMCs

Note: Handling of human blood components should be done in accordance with regional and institutional Biosafety policies and/or requirements.

1. Pre-warm complete RPMI at 37°C for at least 30 minutes.
2. Thaw cells as quickly as possible.
 - a. Thaw cryo-vial (25×10^6 cells) in 37°C water bath, until only small piece of ice remains.
 - b. Transfer contents of cryo-vial to 50 mL conical tube.
 - c. Add 1 ml of warm complete RPMI to cryo-vial. Leave aside until step f.
 - d. Drop-by-drop add 5 ml of warm complete RPMI to the cells in the 50 mL tube. While adding, gently mix the 50 mL tube (with a pipette in one hand and in the other the 50 mL tube, add the complete RPMI while you gently swirl the tube).
 - e. After first 5 ml of complete RPMI have been added, add the next 5 ml a little bit faster (a few drops at a time).
 - f. After 10 ml have been added, pour the contents of the cryo-vial into the 50 mL tube.
 - g. Add additional volume of complete RPMI to complete to 20 ml.
3. Spin at 400 x g for 8 minutes.
4. Decant supernatant carefully without disturbing the pellet.
5. Gently resuspend pellet in 2 ml of warm complete RPMI.
6. Complete to 20 ml.
7. Repeat steps 3 and 4.
8. Resuspend in 7.5 ml of complete RPMI or to an approximate concentration of 3.5×10^6 /ml.
9. Leave in incubator until ready to proceed (rest is not necessary, but once staining has begun, samples will need to be processed without delay).

Viability Dye and Antibody Preparation

1. Thaw aliquot of Live/Dead Blue (dried preparation is resuspended in DMSO following the manufacturer recommendation and 7 µl aliquots are stored at -20°C).
2. Transfer 5 µl of viability dye to a larger Eppendorf and add 195 µl 1X PBS (1:40 dilution).
3. Keep in dark until ready to use.
4. Prepare antibody dilutions as needed.
5. Prepare a master mix of all antibodies in brilliant stain buffer EXCEPT CCR5, CXCR5, and TCRγδ (see [Supplemental Figure 9](#)).

Staining

1. Label 12x75 mm (5 ml) FACS tubes: unstained, SS controls, and MC tubes.
2. Add 700 µL of cell suspension to each MC tube (approximately 2×10^6 cells, to be able to collect enough events for very rare populations).

3. Add 100 μ L of cells (approximately 3×10^5 cells) to each of the SS and unstained controls.
Note: Ideally, all controls should be cells, however, some antibody reagents showed no difference between cells and beads as reference controls, and in those cases, beads can be used. In this protocol, we used UltraComp eBeads™ Compensation Beads from ThermoFisher, however, beads from other manufacturers may perform differently. See [step 2](#) under Panel Testing above.
4. MC and SS viability tubes need to be washed with PBS only.
Note: Viability dye is an amine reactive dye and will be bound by any proteins in the buffer, so it is important to make sure the wash buffer is free of protein.
5. All other SS controls and MC tubes are washed with wash buffer, 3 ml per tube.
6. Spin at 500 x g for 5 minutes.
7. Carefully decant supernatant.
8. Add 5 μ L of viability dye dilution to MC AND Viability SS control; vortex and incubate for 15 minutes at room temperature in the dark.
9. In the meantime, start staining SS controls with the pre-determined optimal amount of antibody.
10. After 15 minute incubation, wash MC and SS viability tubes with wash buffer.
11. Repeat steps 6 and 7.
12. Add 300 μ L of wash buffer to SS viability tube, vortex, store at 4°C.
13. Add 10 μ L of Brilliant Stain Buffer Plus to all MC tubes. Vortex well.
14. Add 5 μ L of True-Stain Monocyte Blocker; vortex.
15. Add anti-TCR $\gamma\delta$; vortex.
16. Incubate for 10 minutes at room temperature in the dark.
17. Add anti-CXCR5 and anti-CCR5; vortex.
18. Incubate for 10 minutes at room temperature in the dark.
19. Add the remainder of antibodies from the MC mix cocktail; vortex.
20. Incubate at room temperature in the dark for 30 minutes.
21. Finish staining/washing SS controls.
22. Wash all tubes with 3 ml of wash buffer.
23. Decant supernatant carefully, then resuspend the pellet.
24. Add 300 μ L of 1% paraformaldehyde (PFA) in PBS to all tubes, including SS control tubes; vortex.
Note: It is very important to treat the SS controls in the same manner as the MC samples, including the fixation step. This is true whether beads or cells are used as SS controls. Fluorochrome emission properties can be slightly altered depending on their microenvironment. For accurate unmixing/compensation, SS controls need to be treated exactly the same as the MC stained sample. If necessary due to biosafety issues, 4% PFA can be used. Some reduction in intensity for some markers may occur after fixation with this high concentration of PFA as described in the literature ([16](#)). CD45RA for example is one of the markers that is impacted, but the resolution with the conjugate in this panel should still be optimal.
25. Incubate for 20 minutes at room temperature.
26. Repeat steps 6 and 7.
27. Resuspend pellet in 400 μ L of wash buffer.
28. Store at 4°C protected from light until ready to acquire on the instrument.

REFERENCES

1. Roederer M. Spectral compensation for flow cytometry: visualization artifacts, limitations, and caveats. *Cytometry* 2001;45:194-205.
 2. Roederer M. Distributions of autofluorescence after compensation: Be panglossian, fret not. *Cytometry A* 2016;89:398-402.
 3. Nguyen R, Perfetto S, Mahnke YD, Chattopadhyay P, Roederer M. Quantifying spillover spreading for comparing instrument performance and aiding in multicolor panel design. *Cytometry A* 2013;83:306-15.
 4. Mahnke YD, Roederer M. Optimizing a multicolor immunophenotyping assay. *Clin Lab Med* 2007;27:469-85, v.
 5. Mair F, Prlic M. OMIP-044: 28-color immunophenotyping of the human dendritic cell compartment. *Cytometry A* 2018;93:402-405.
 6. Hammer Q, Romagnani C. OMIP-039: Detection and analysis of human adaptive NKG2C(+) natural killer cells. *Cytometry A* 2017;91:997-1000.
- OMIP-069: 40 Color Deep Immune Profiling

7. Biosciences B. Anti-Mouse Ig, κ /Negative Control Compensation Particles Set:BD™ CompBeads. In: Biosciences B, editor. Technical Data Sheet. 552843 Rev. 5 ed. BD Biosciences.com; 2017. p 1-2.
8. Jalbert E, Shikuma CM, Ndhlovu LC, Barbour JD. Sequential staining improves detection of CCR2 and CX-3CR1 on monocytes when simultaneously evaluating CCR5 by multicolor flow cytometry. *Cytometry Part A* 2013;83A:280-286.
9. Chester C, Maecker HT. Algorithmic Tools for Mining High-Dimensional Cytometry Data. *J Immunol* 2015;195:773-9.
10. Mair F, Hartmann FJ, Mrdjen D, Tosevski V, Krieg C, Becher B. The end of gating? An introduction to automated analysis of high dimensional cytometry data. *Eur J Immunol* 2016;46:34-43.
11. Palit S, Heuser C, de Almeida GP, Theis FJ, Zielinski CE. Meeting the Challenges of High-Dimensional Single-Cell Data Analysis in Immunology. *Front Immunol* 2019;10:1515.
12. Becht E, McInnes L, Healy J, Dutertre CA, Kwok IWH, Ng LG, Ginhoux F, Newell EW. Dimensionality reduction for visualizing single-cell data using UMAP. *Nat Biotechnol* 2018.
13. Meskas J, Wang S, Brinkman R. flowCut — An R package for precise and accurate automated removal of outlier events and flagging of files based on time versus fluorescence analysis. *bioRxiv* 2020.
14. McInnes L, Healy J, Melville J. UMAP: Uniform Manifold Approximation and Projection for Dimension Reduction; ArXiv e-prints 2018.
15. Van Gassen S, Callebaut B, Van Helden MJ, Lambrecht BN, Demeester P, Dhaene T, Saeys Y. FlowSOM: Using self-organizing maps for visualization and interpretation of cytometry data. *Cytometry A* 2015;87:636-45.
16. Stewart JC, Villasmil ML, Frampton MW. Changes in fluorescence intensity of selected leukocyte surface markers following fixation. *Cytometry A* 2007;71:379-85.