

NON SYNDROMIC HEARING IMPAIRMENT

Family 1 : CIB2-Arg104Ter

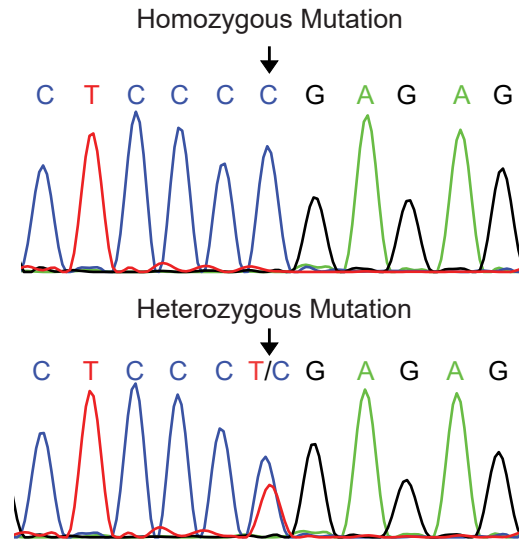

Family 2 : ESRRB-Tyr295Cys

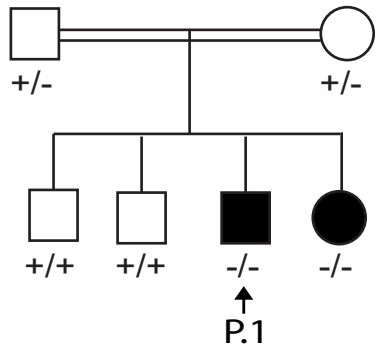
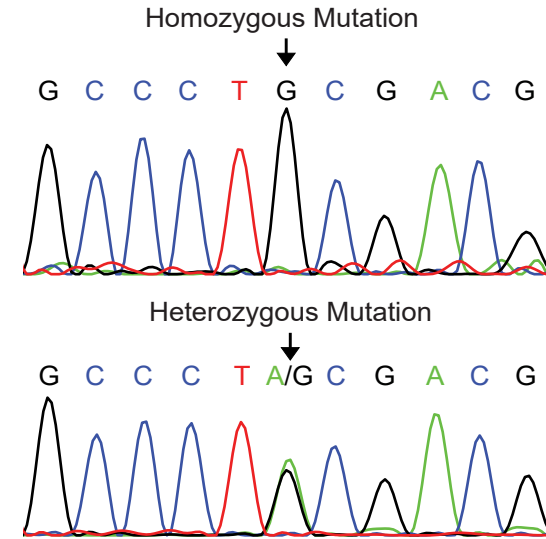
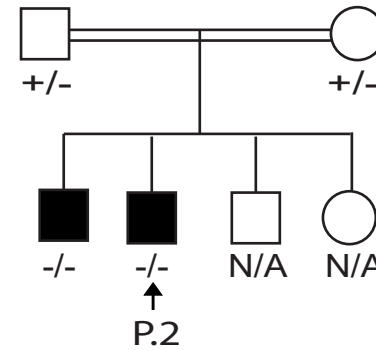

Family 3 : WHRN-Gly808AspfsX11

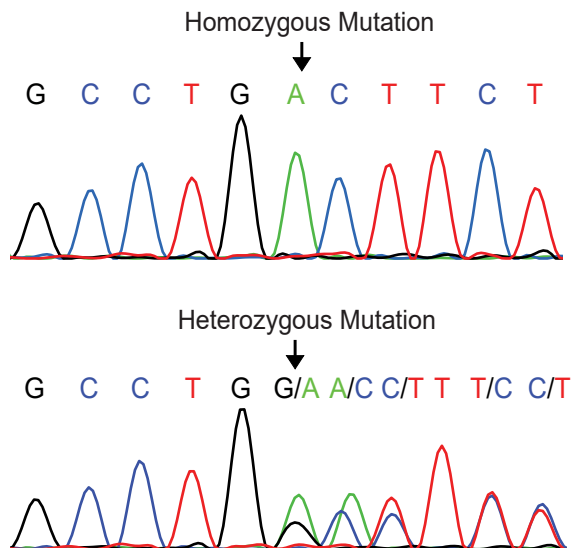
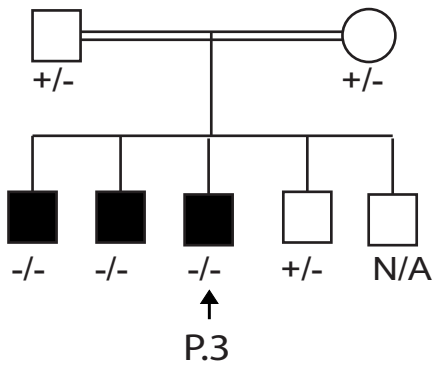

Family 4 : OTOF-Glu57Ter

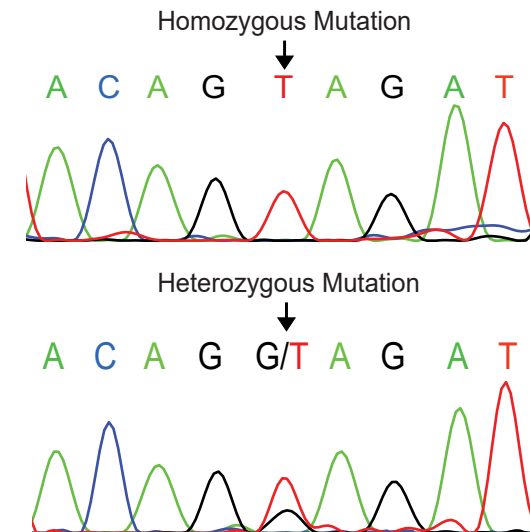
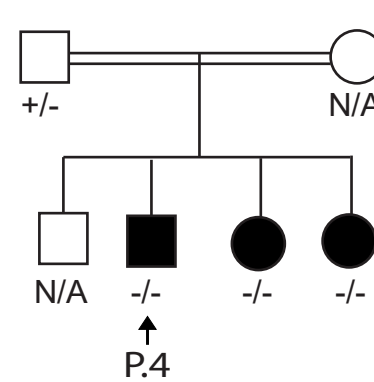

NON SYNDROMIC HEARING IMPAIRMENT

Family 5 : MYO15A-Phe2089Leu

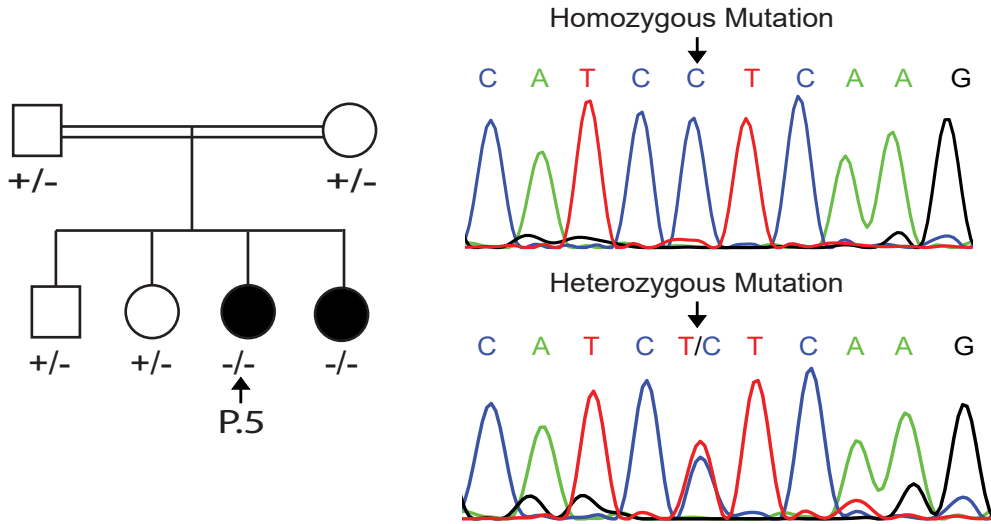

Family 6 : SLC22A4-Cys113Tyr

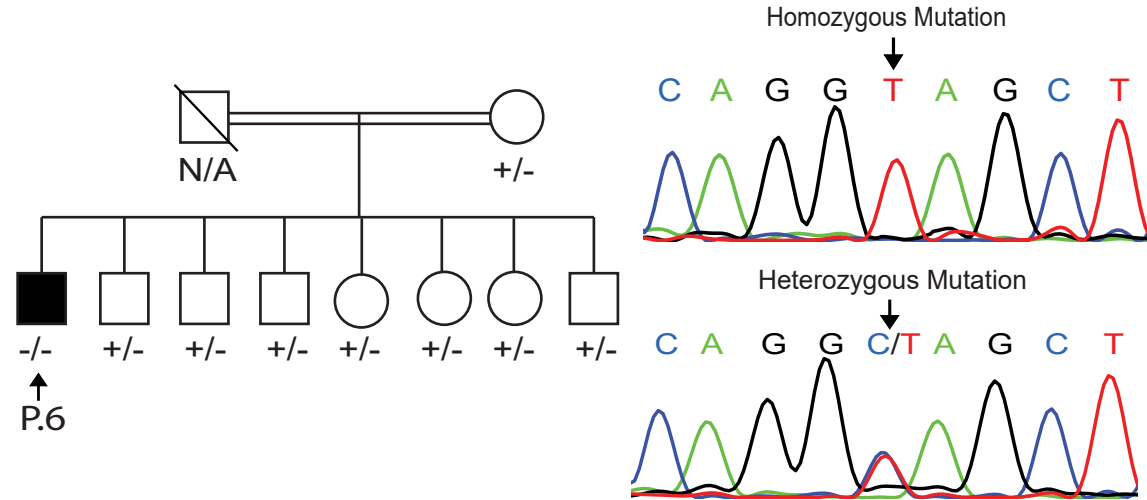

Family 7 : PNPT1-Glu475Gly

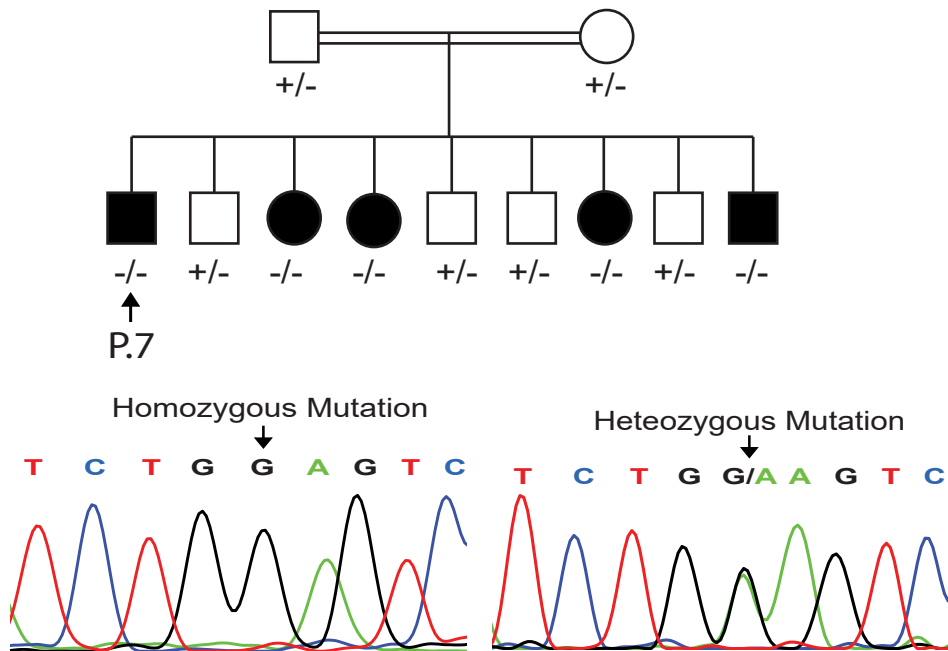

Family 8 : OTOA-Val603Phe

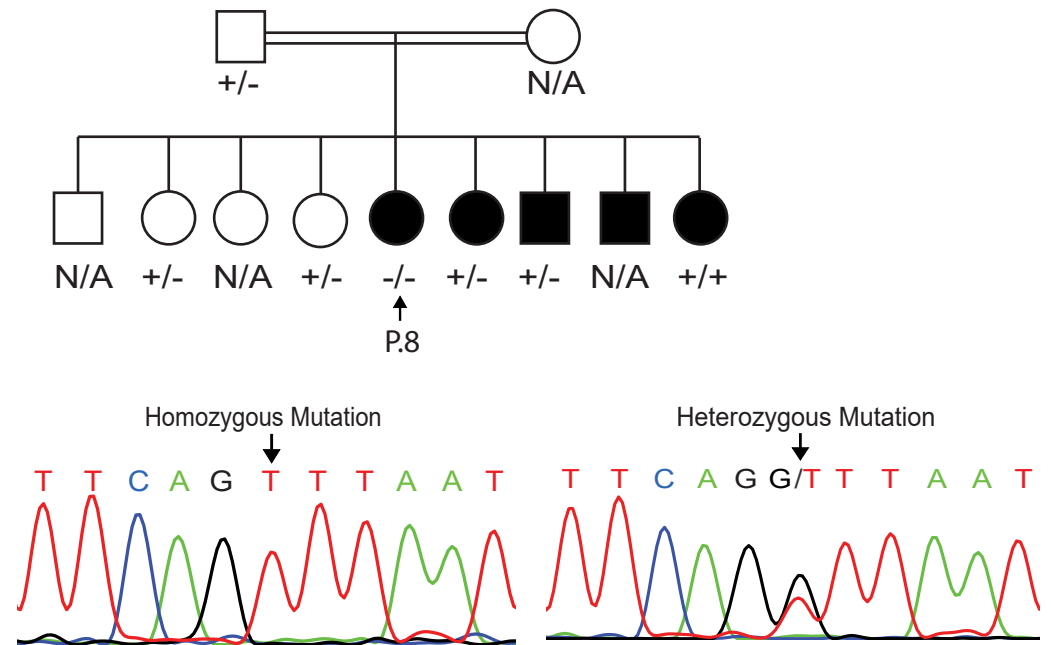

USHER SYNDROME

Family 10 : USH1C- Gln122Ter

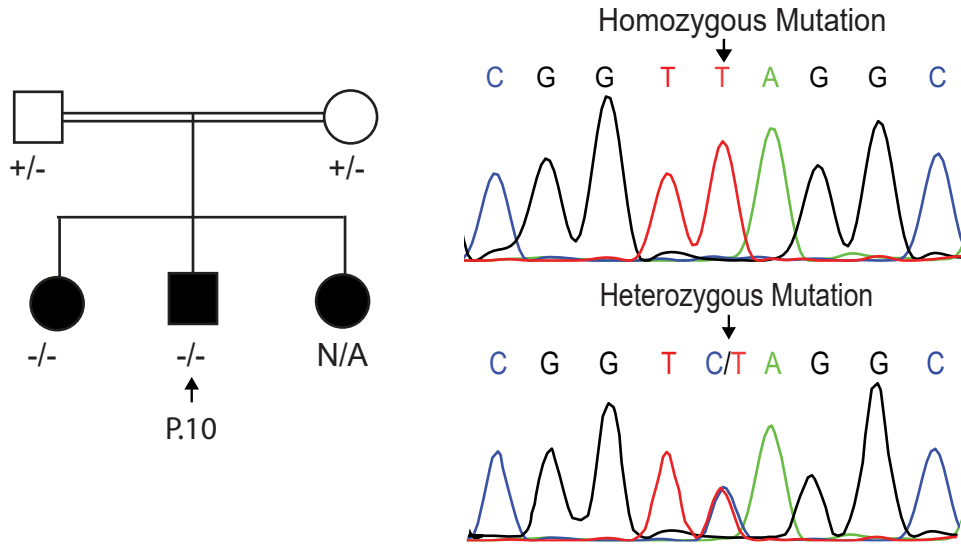

Family 11 : MYO7A-Tyr560Cys

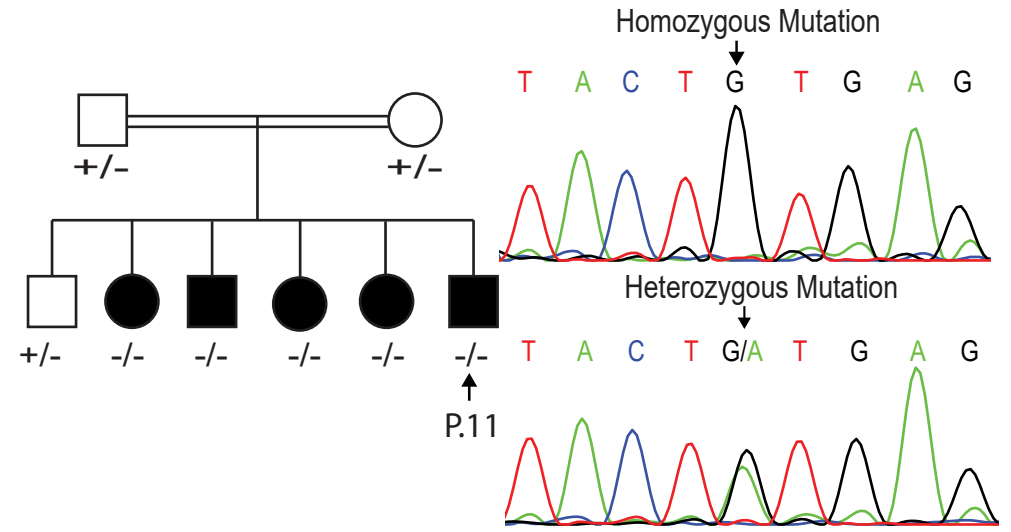

**Family 12 : MYO7A c.470+1G>A
MYO7A c.2283-1G>T**

