

Supple. Fig. 1A. Network architecture: Overall structure of CycleGAN

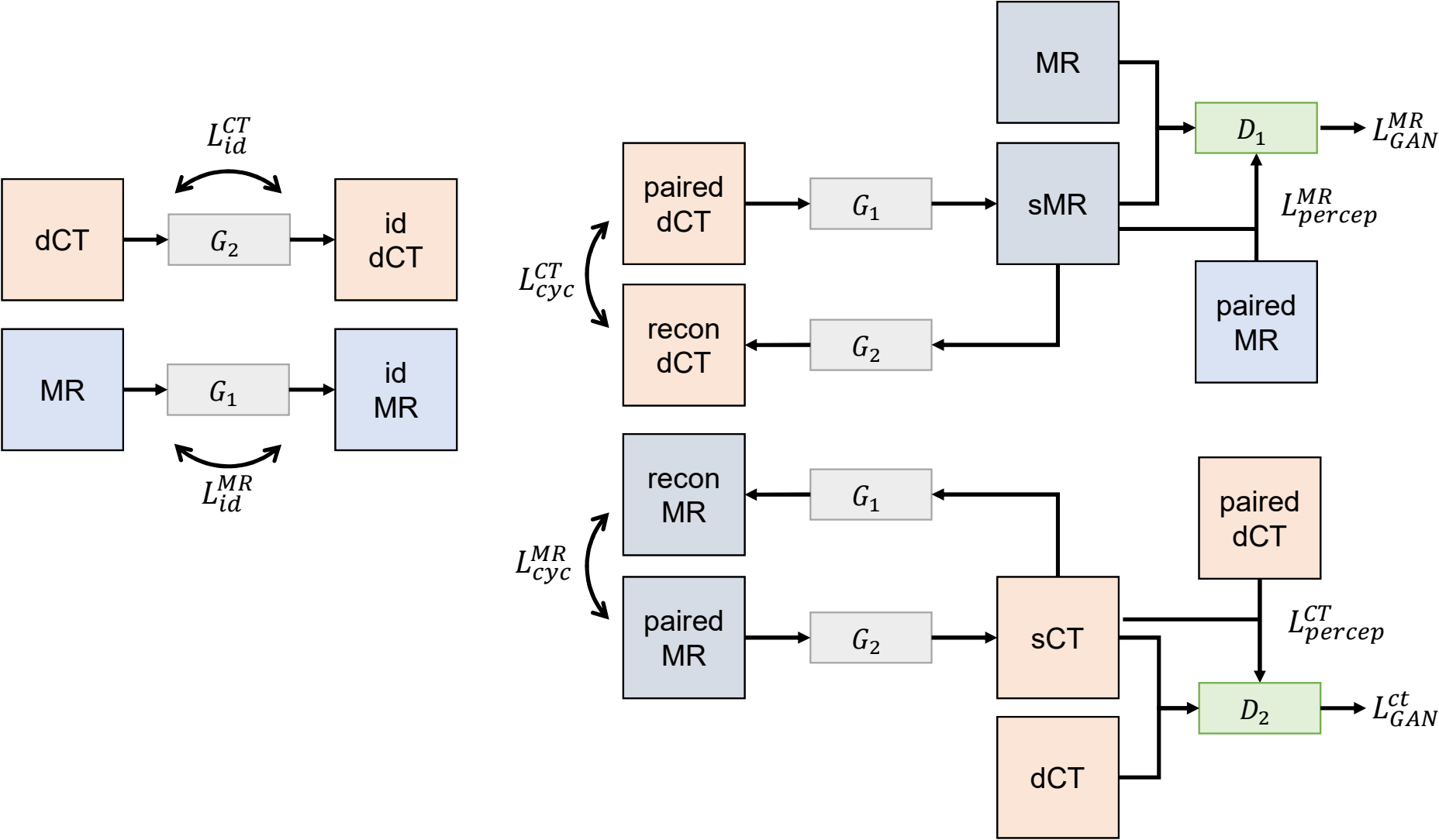

Supple. Fig. 1B. Network architecture: Generator model with U-net structure

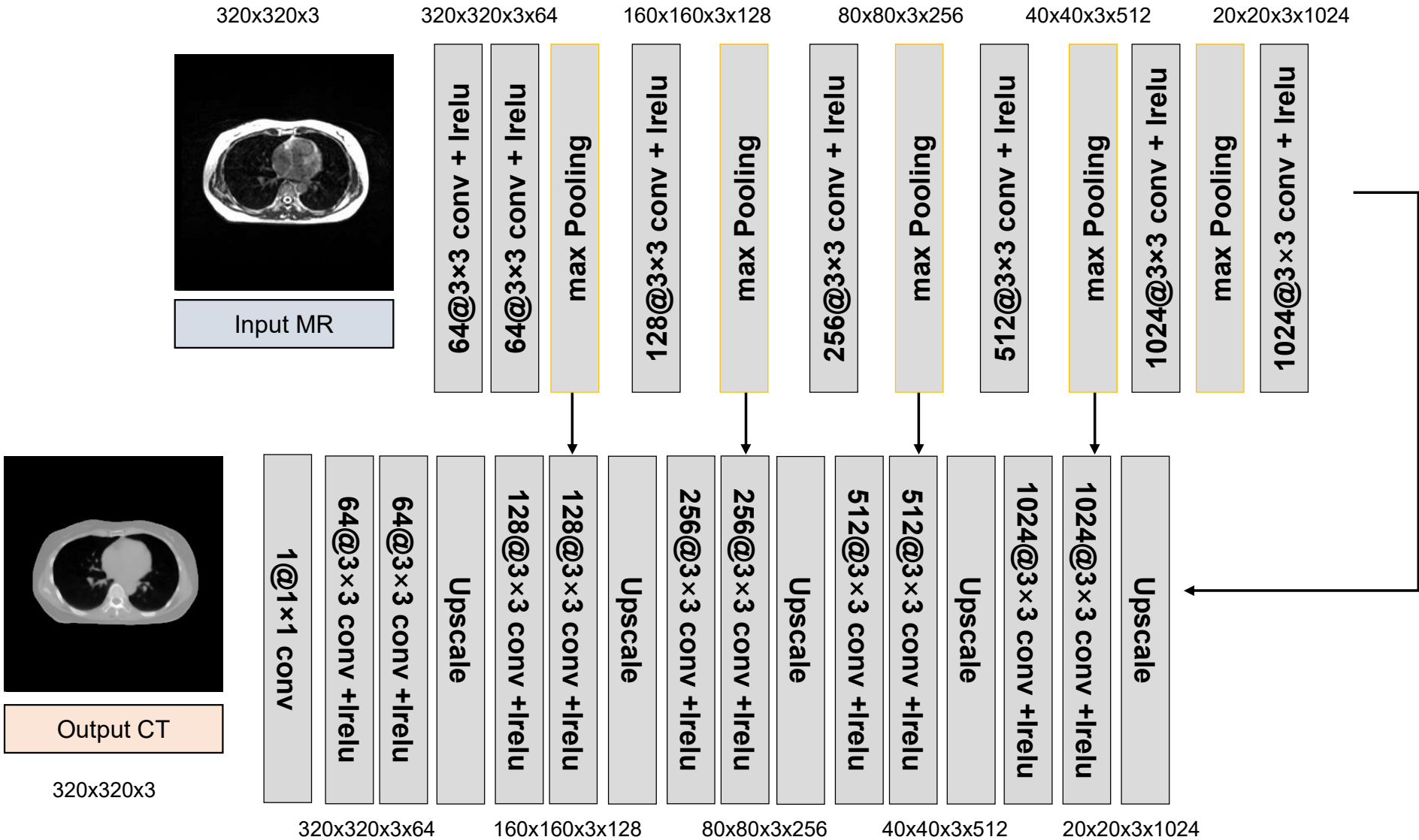

Supple. Fig. 1C. Network architecture: Discriminator model with ResNet structure and perceptual loss.

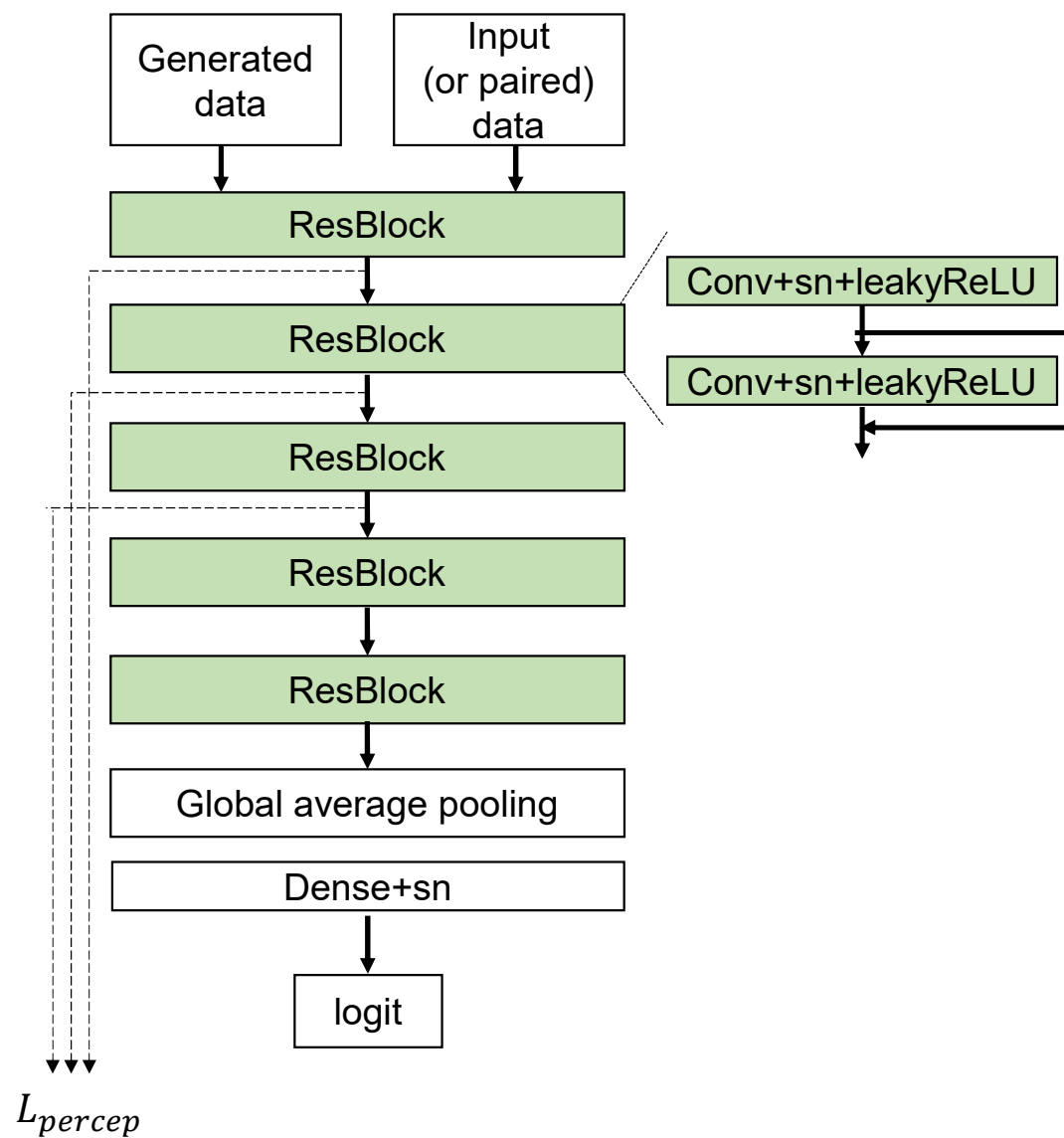

Supple. Fig. 2. Improvement of CycleGAN by incorporating perceptual loss

