

Supplemental Figure Document

Supplemental Figure 1.

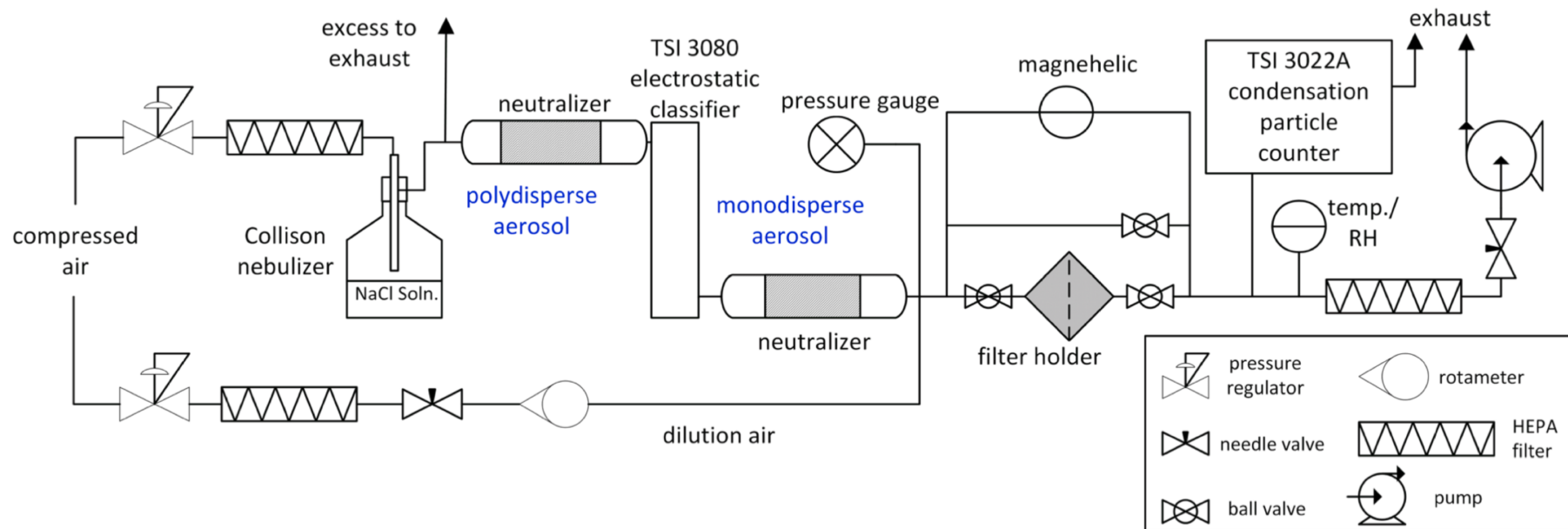
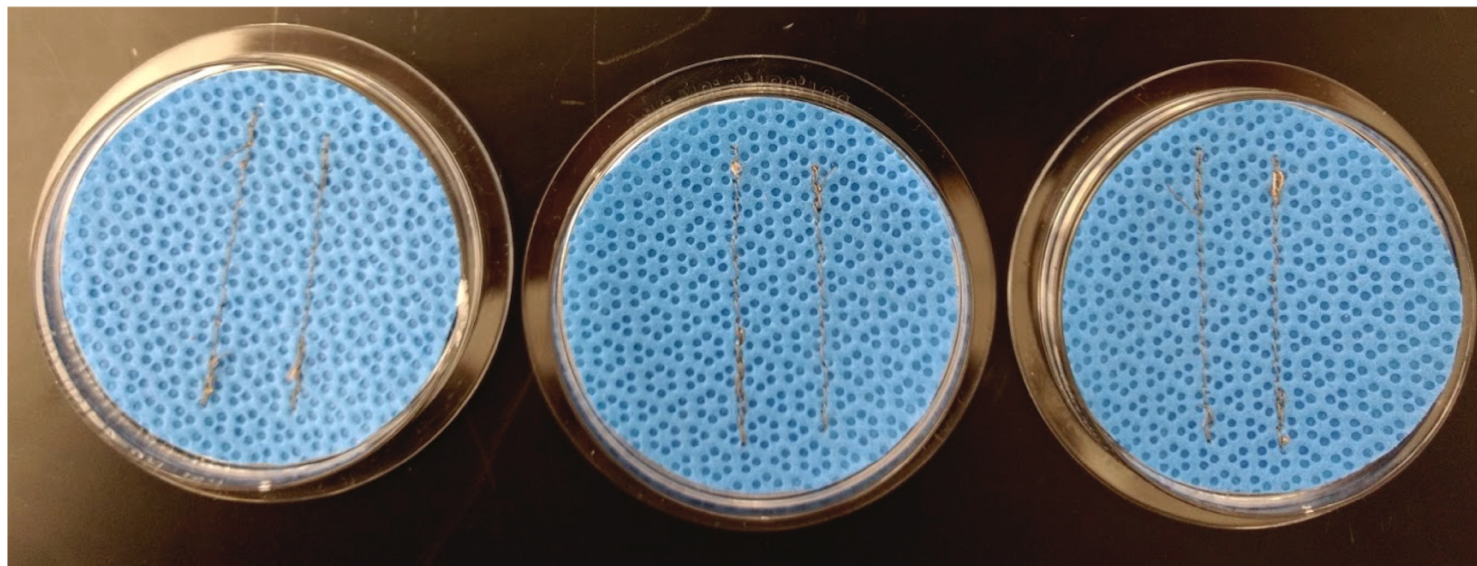

Supplemental Figure 1. Flow diagram of the aerosol filtration testing station.

Supplemental Figure 2.

Supplemental Figure 2. 47 mm discs were cut from H600 sterilization wrap fabric sheets (Halyard Health, Alpharetta, GA) and stitched with two straight lines using a sewing machine. The total length of stitching on each of the three filters was 6.7, 6.5, and 7.0 cm.

Supplemental Figure 3.

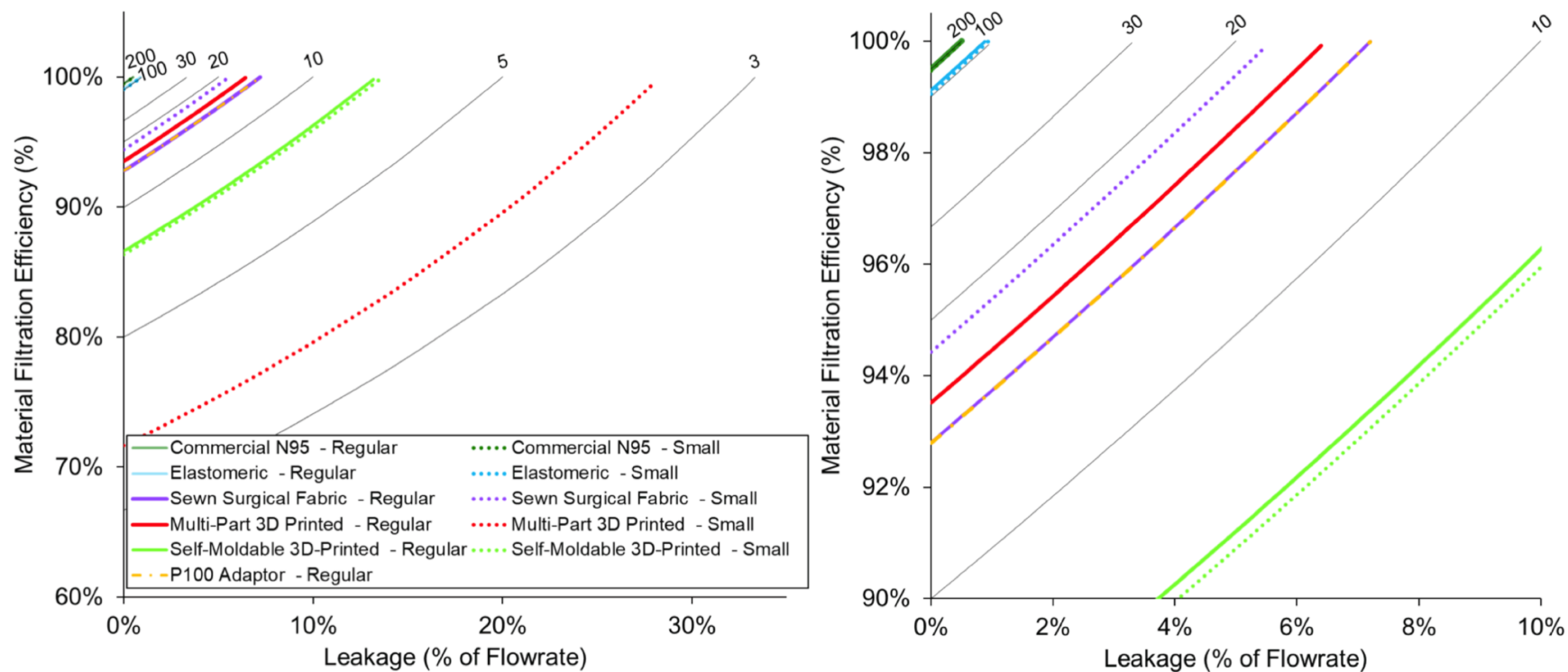

Supplemental Figure 3. Lines represent combinations of material filtration efficiency performance (%) and leakage (ie. around the face seal or through defects; % of flowrate) which result in a given fit factor.

Supplemental Figure 4.

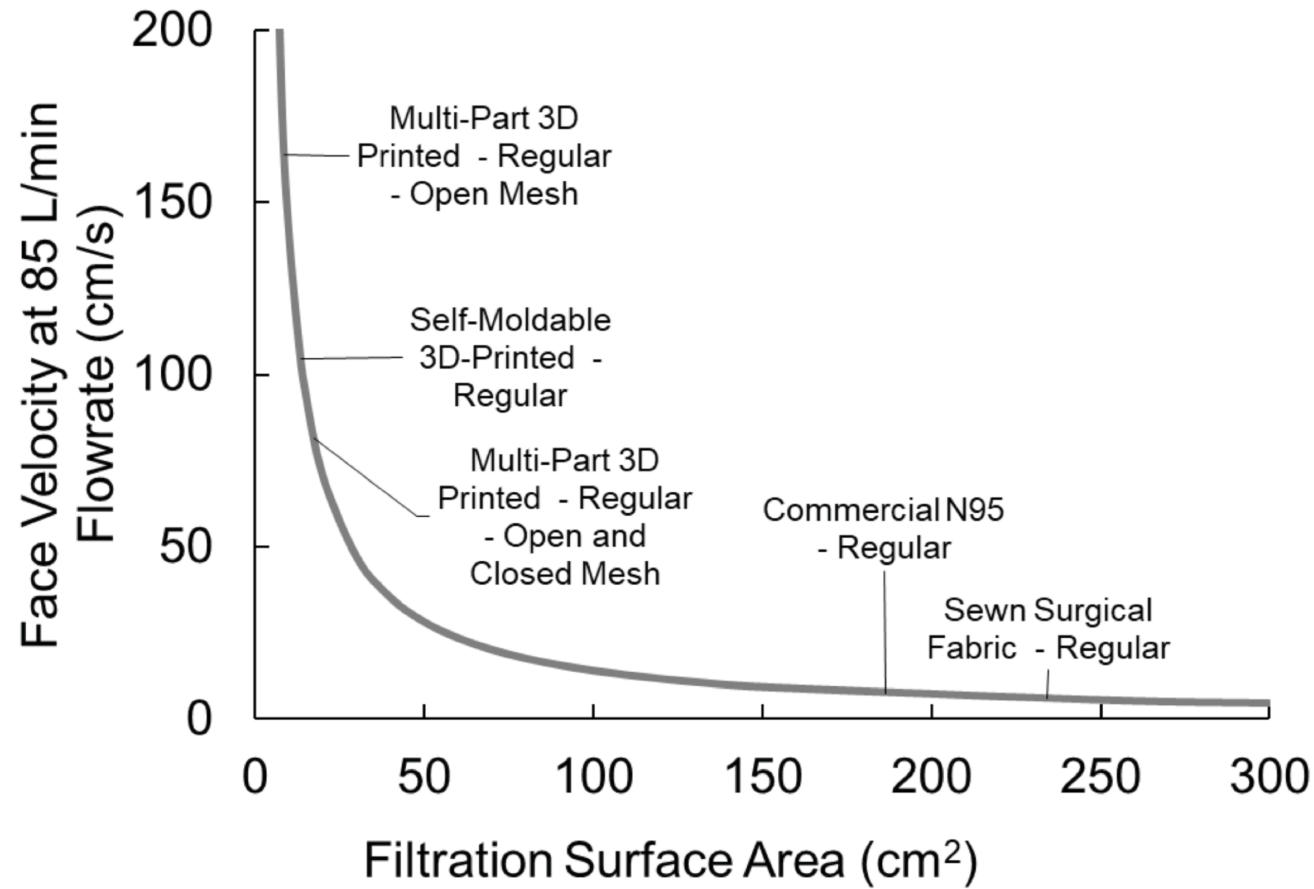

Supplemental Figure 4. Face velocity of 85 L/min as a function of filtration surface area.

Supplemental Figure 5.

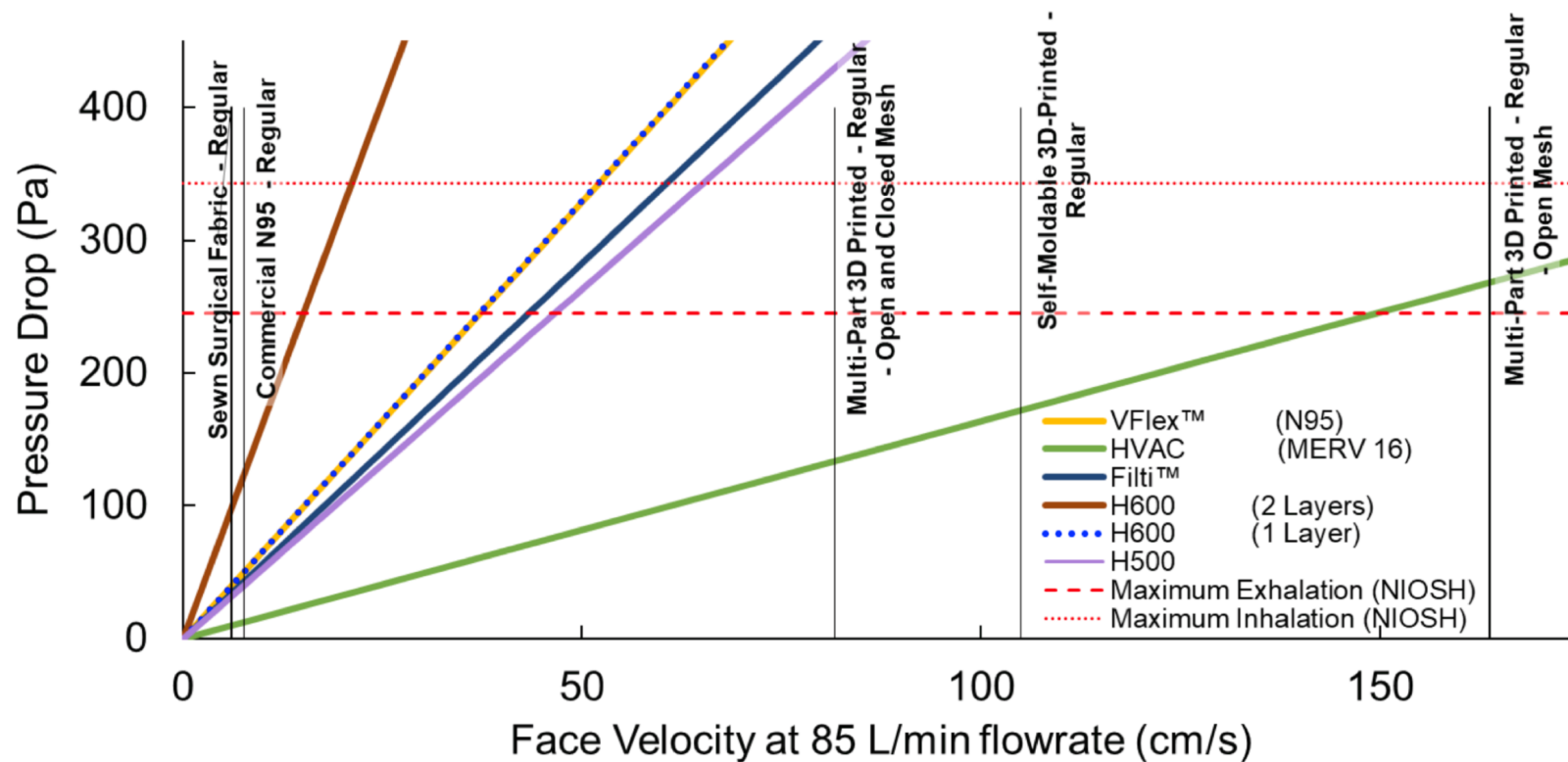

Supplemental Figure 5. For several materials, pressure drop is modeled as a function of face velocity. Vertical lines represent the characteristic face velocity for 85 L/min flowrate through the filtration area of the improvised designs.