

# Construction of Conditional Targeting Vector for *Htr4*<sup>Floxed</sup>

## 1. Vector Design Outline

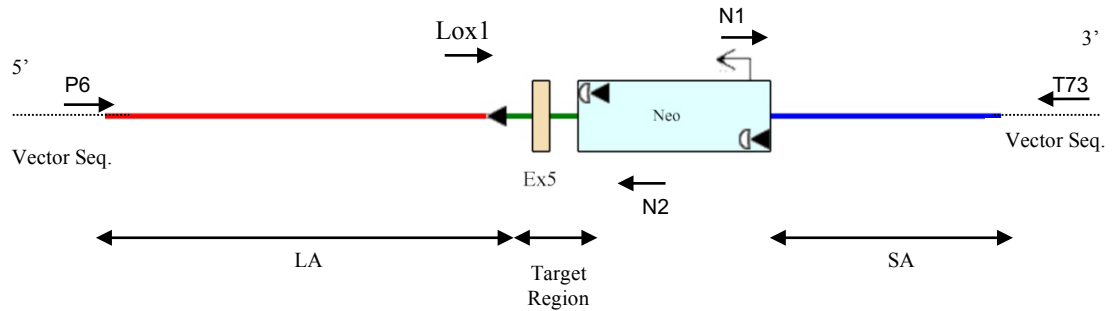

Ex5: *Htr4* exon 5

LA: Long arm

SA: Short arm

Neo: Neomycin resistance cassette

Black triangles: LoxP sites

White semicircles: FRT sites

## 2. Sequence Data Analysis

### PCR primers used for sequencing:

Primer P6: 5' - GAG TGC ACC ATA TGG ACA TAT TGT C -3'  
Primer T73: 5' - TAA TGC AGG TTA ACC TGG CTT ATC G -3'  
Primer N1: 5' - TGC GAG GCC AGA GGC CAC TTG TGT AGC -3'  
Primer N2: 5' - TTC CTC GTG CTT TAC GGT ATC G -3'  
Primer lox1: 5' - GGA CAG CAA TCT AAG GAG CAC AG -3'

### 3. Assembled Htr4<sup>Floxed</sup> targeting vector

1. Vector backbone: Blue text (e.g., ATCG)
2. LA (4820 bp): Bold and italic text (e.g., *atcg*)
3. Distal loxP (67 bp): Lightgray text, highlighted in yellow (e.g., ATCG)
4. MA (752 bp): Green text (e.g., ATCG)
5. Neo (1713 bp): Red text (e.g., ATCG)
6. SA (2347 bp): Underlined text (e.g., ATCG)
7. LoxP: Red text, highlighted in yellow (e.g., ATCG)
8. FRT: Red and underlined text, highlighted in gray (e.g., ATCG)
9. Exon: Highlighted in pink (e.g., ATCG)
10. Genotyping forward primer – Htr4 loxP F (TCGAGGCATTCTCGATTCA)
11. Genotyping reverse primer – Htr4 loxP R (TAACACCTGGCCGAAACGTT, reverse transposed)

#### 3'end of BAC subclone joins here.

```
CGATGATATCAGATCTGCCGGTCTCCCTATAGTGAGTCGTATTAATTTTCGATAAGCCAGGTTAACCTGCAT
TAATGAATCGGCCAACGCGCGGGGAGAGGCGGTTTTCGCTATTGGGCGCTCTTCCGCTTCCCTCGCTCACTGA
CTCGCTGCGCTCGGTTCGTTTCGCTGCGGCGAGCGGTATCAGCTCACTCAAAGGCGGTAATACGGTTATCCA
CAGAATCAGGGGATAACGCAGGAAAGAACATGTGAGCAAAGGCCAGCAAAGGCCAGGAACCGTAAAAAG
GCCGCGTTGCTGGCGTTTTTCCATAGGCTCCGCCCCCTGACGAGCATCACAAAATCGACGCTCAAGTCA
GAGGTGGCGAAACCCGACAGGACTATAAAGATACCAGGCGTTTTCCCCTGGAAGCTCCCTCGTGCGCTCTC
CTGTTCCGACCCTGCCGCTTACCGGATACCTGTCCGCTTTTCTCCCTTCGGGAAGCGTGGCGCTTTTCTCAT
AGCTCACGCTGTAGGTATCTCAGTTCGGTGTAGGTGCTTCGCTCCAAGCTGGGCTGTGTGCACGAACCCCC
CGTTCAGCCCCGACCGCTGCGCCTTATCCGGTAACTATCGTCTTGAGTCCAACCCGGTAAGACACGACTTAT
CGCCACTGGCAGCAGCCACTGGTAACAGGATTAGCAGAGCGAGGTATGTAGGCGGTGCTACAGAGTTCTTG
AAGTGGTGGCCTAACTACGGCTACACTAGAAGAACAGTATTTGGTATCTGCGCTCTGCTGAAGCCAGTTAC
CTTCGGAAAAAGAGTTGGTAGCTCTTGATCCGGCAAACAAACCCGCTGGTAGCGTTGGTTTTTTGGTTT
GCAAGCAGCAGATTACGCGCAGAAAAAAGGATCTCAAGAAGATCCTTTGATCTTTTCTACGGGGTCTGAC
GCTCAGTGAACGAAAACCTCACGTTAAGGGATTTTGGTCATGAGATTATCAAAAAGGATCTTACCTAGAT
CCTTTTTAAATTAATAATGAAGTTTTAAATCAATCTAAAGTATATATGAGTAACTTGGTCTGACAGTTACC
AATGCTTAATCAGTGAGGCACCTATCTCAGCGATCTGTCTATTTTCGTTTCATCCATAGTTGCCTGACTCCCC
GTCGTGTAGATAACTACGATACGGGAGGGCTTACCATCTGGCCCCAGTGCTGCAATGATACCGCGAGACCC
ACGCTCACCGGCTCCAGATTTATCAGCAATAAACCAGCCAGCCGGAAGGGCCGAGCGCAGAAGTGGTCCTG
CAACTTTATCCGCTCCATCCAGTCTATTAATTGTTGCCGGGAAGCTAGAGTAAGTAGTTCCGCCAGTTAAT
AGTTTGCACAACGTTGTTGCCATTGCTACAGGCATCGTGGTGTACGCTCGTCTGTTGGTATGGCTTCATT
CAGCTCCGTTTCCCAACGATCAAGGCGAGTTACATGATCCCCATGTTGTGCAAAAAGCGGTTAGCTCCT
TCGGTCTCCGATCGTTGTGAGAAGTAAGTTGGCCGCGAGTGTATCACTCATGGTTATGGCAGCACTGCAT
AATTCTCTTACTGTCATGCCATCCGTAAGATGCTTTTCTGTGACTGGTGAGTACTCAACCAAGTCATTCTG
AGAATAGTGTATGCGGCGACCGAGTTGCTCTTGCCCGGCGTCAATACGGGATAATACCGCGCCACATAGCA
GAACTTTAAAAGTGCTCATCATTGGAAAACGTTCTTCCGGGGCGAAAACCTCTCAAGGATCTTACCGCTGTTG
AGATCCAGTTCGATGTAACCCACTCGTGCACCCAACCTGATCTTTCAGCATCTTTTACTTTTACCAGCGTTTC
TGGGTGAGCAAAAACAGGAAGGCAAAATGCCGCAAAAAGGGAATAAGGGCGACACGGAAATGTTGAATAC
TCATACTCTTCTTTTTCAATATTATTGAAGCATTATCAGGGTTATTGTCTCATGAGCGGATACATATTT
GAATGTATTTAGAAAAATAAACAATAGGGGTTCCGCGCACATTTCCCCGAAAAGTGCCACCTGACGCTCA
AGAAACCATATTATCATGACATTAACCTATAAAAATAGGCGTATCACGAGGCCCTTTCGCTCTCGCGCGTT
TCGGTGATGACGTTGAAAACCTCTGACACATGCAGCTCCCGGAGACGGTACAGCTTGTCTGTGTAAGCGGAT
GCCGGGAGCAGACAAGCCCGTCAGGGCGCGTCAGCGGGTGTGGCGGGTGTGCGGGTGGCTTAACTATGC
GGCATCAGAGCAGATTGTAAGTGTGAGAGTGCACCATATGGACATATTGTGCTTAGAACGCGGCTACAATTAAT
ACATAACCTTATGTATCATACATACGATTTAGGTGACACTATACCTGCAGGCGCGCCATTTAAATGCGG
```





ATCTAATCTCTTTGTGAAAAAATCACAGTATTTTCTCTTATGAAAATAATGTGAAATATGTGGAATAAAG  
GCTCCTTAGCAGGTGTTTTCAAATATTTTTTTAACATTACAGTGAATCAGACATTACAATAAGGAATGACAT  
TACAATAAGGAATTATACTTTTTGGAAAGAGTATAATTATGGCAGTTTAAAGATGTGCAGGTTAATTTGCAC  
TTCCCATGACACATAGTTTTCTATAAAAAAGAGTTTTAATTTTCAATTTATTTTATATATTTATTAAATATTT  
ATTGATATTTATAAATCAGTTTTCCAGAACTTGAGGCATATCATGTCCCAAGAAGTCTTCGTTATATTTTCAT  
ATTGAGTCTATAAGGATTACAGTGCCTATGGAAAGGCATACCAAGTAAATGGACAATGCCAAGGAATATGA  
AAATCCTGGGCCAGAAGTCAGGAACCTAAGCTGTGAGCCCAGCTCTGCTAATGCCCAACTTCCTGAAGAACT  
GTATTAAGAAGGGAAGTTGGTGTGAGTGAAAAATTGTCTAGTGTGAGTCTAAGGGGACCCATGCCACATA  
GGCCATACATTGTCCAAACTCTGGATATTGTTTTCCAGAGACATAGAACTAATAGGATGTTTGTGTGCATA  
TGTTTCATCTATCTGTCTATCCATCTATATGTCTATCCACCTATCTGTCCATGAATCTATCTGTCATCTATC  
TGCTGTCTGTCTAACCATCTATCTACTATCTATTATCTATCTAACTATCTATCTGTCTGTCTGTCTGTCT  
AACCAACCATCTATCTACTATCTATTATCTATATATCTACATTTCTATTTATCTTCTAATCTATCTAATCT  
ATCTATCTATCTATCTATCTATCTATCTATCTATCTATCTATCTATCTATCTATCTATCTATCTATCTAT  
CTATTTACCTATACACTTAGAAAAAGAAAAAGAGAAACAGAGGCAGACATATAGACATATTGTAACCTGGTC  
CTCCTGGTTGTGGAAGTTGATAATTCTCAGCAAACCTAGAGACTGAGGAAAGGCAATATTTCAACTCAAGTC  
CAAATATAGGAAAAAACTGATGGCCTTCATTAAGTCAATAGAGCAGTTCCTCTTATTTCGGTTATTTTGT  
CTATTTGGGCCTTTAATAGAGTTAGATGCAGTGCTAAATCGGAAGAGAAAAATGGATTTATACAATCTGCCA  
GTACAGAGCTTAATCTCAATCCCAAATGTTGTCGTACACAAAATTGGGTTTTACCAATTATCTGGATACCT  
ATGACTTGGTTACACTGGCACATAACATTAACCATCTTGCTGTCAAATCATCTACTCTGGCACACCAAAT  
TATAATGATGATTAATAACTGATAGTCCAGATTCATTGTGAGGGCTATACATTTCTAAAGGAATATGGCATG  
CAGTCACTTATAGCCAGTCTAAGATCTTGCTAGATGTGGAGAAGGGGGCAGAAAGAAGAGGTTGAGAATG  
AAGAATGAGTTCTGACCCAAGTGGATCAGAAAAAAGAGAATTTGCCTTCTTTTCTGCACACCTAAGGACT  
TTAATTTTTATTTTCAAATGAGTCCCATGGCCAGGACATTTTCTGAGTA

**5' end of BAC subclone joins here.**