

Supplementary information

CRL4 is a master regulator of D-type cyclins

In the format provided by the
authors and unedited

Figure 1a

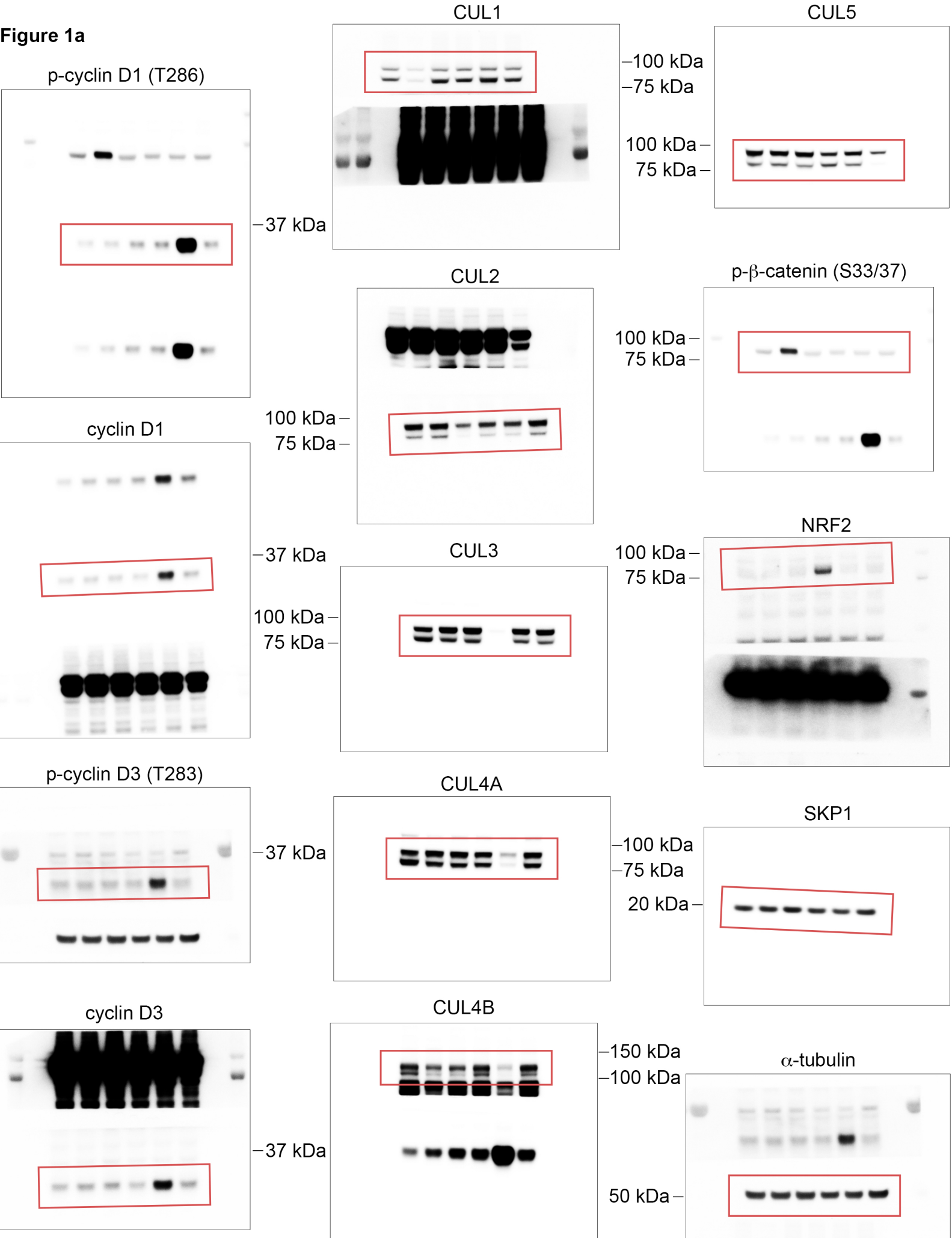

Figure 2a

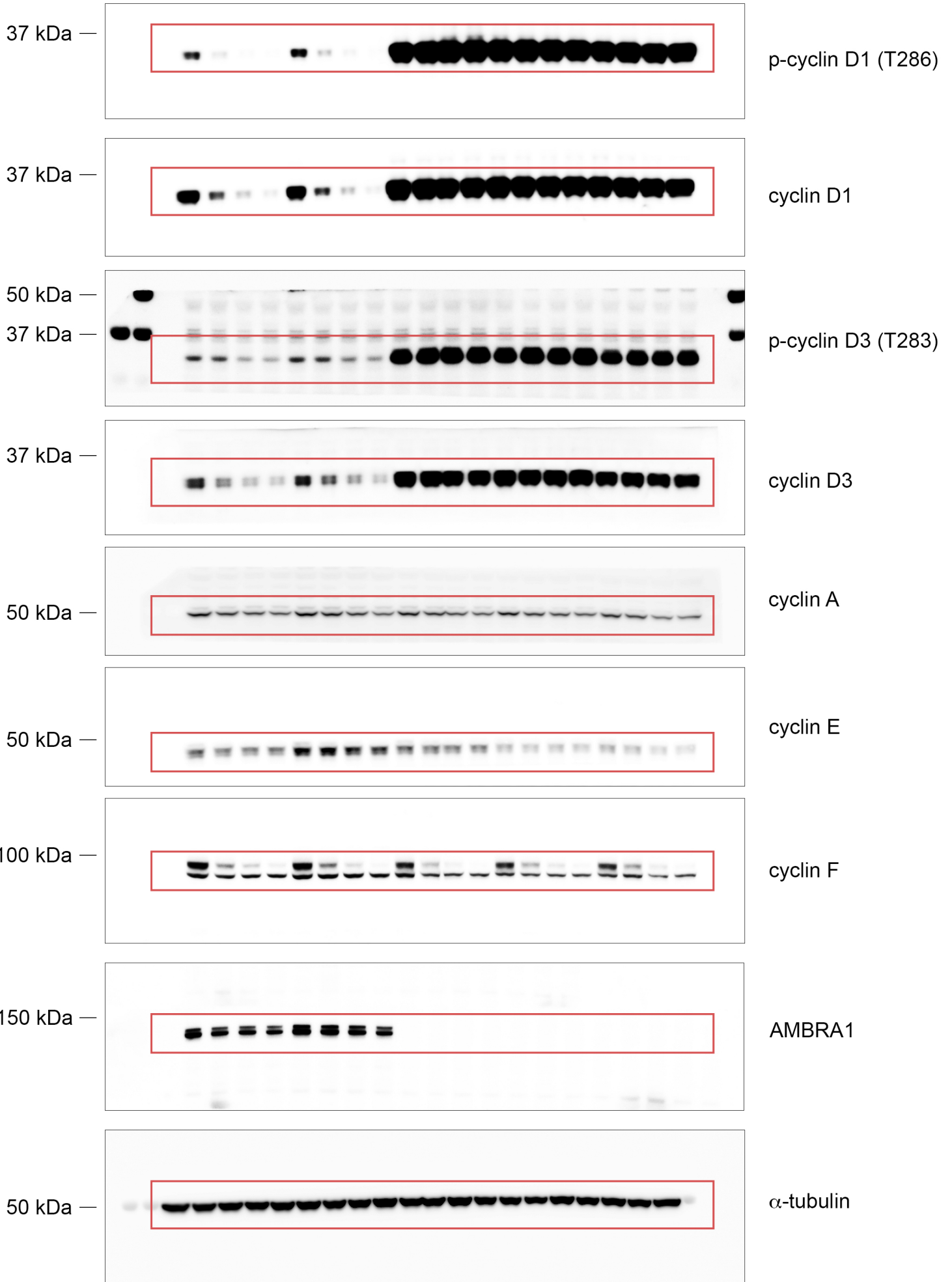

Figure 2b

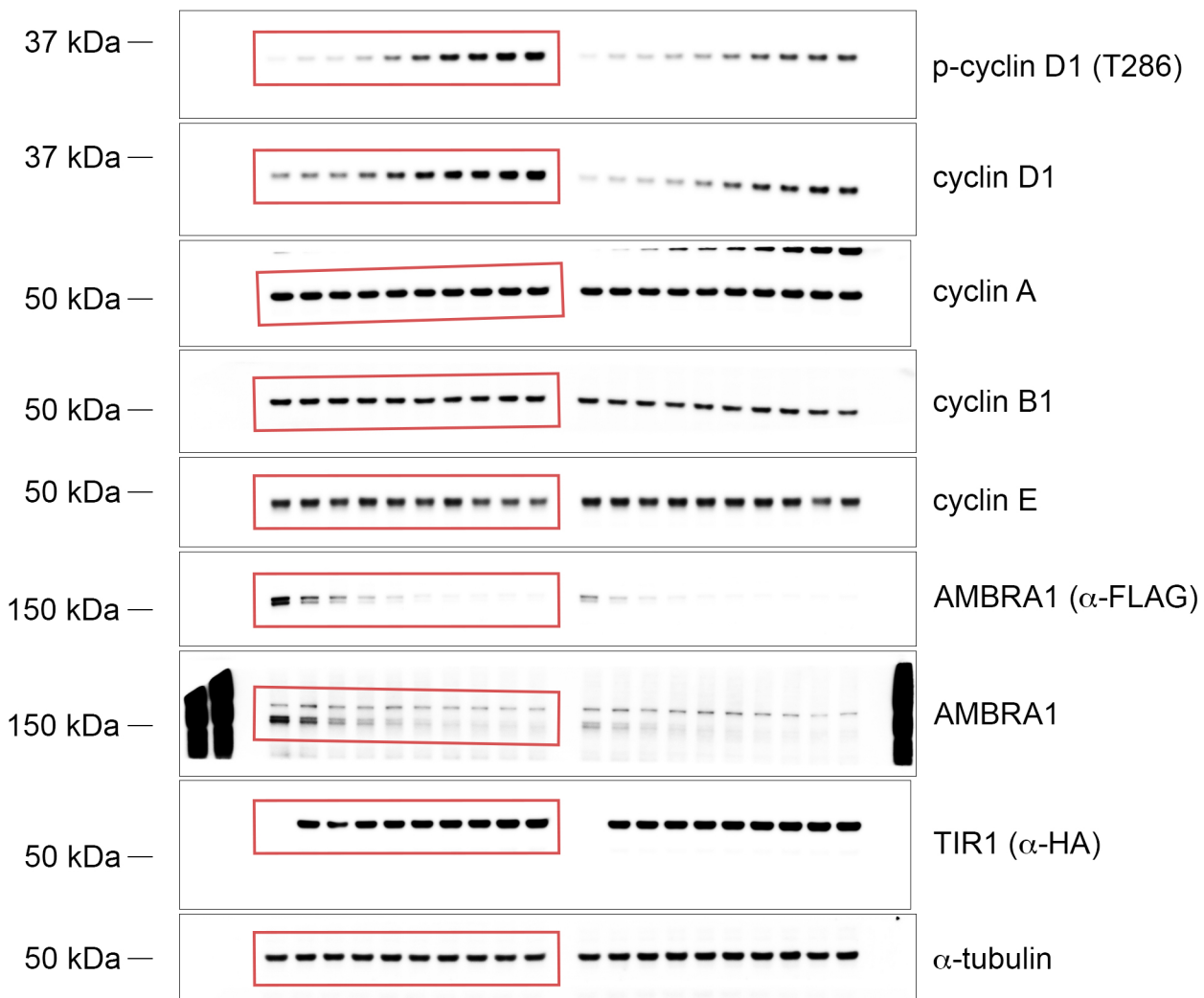

Figure 2c

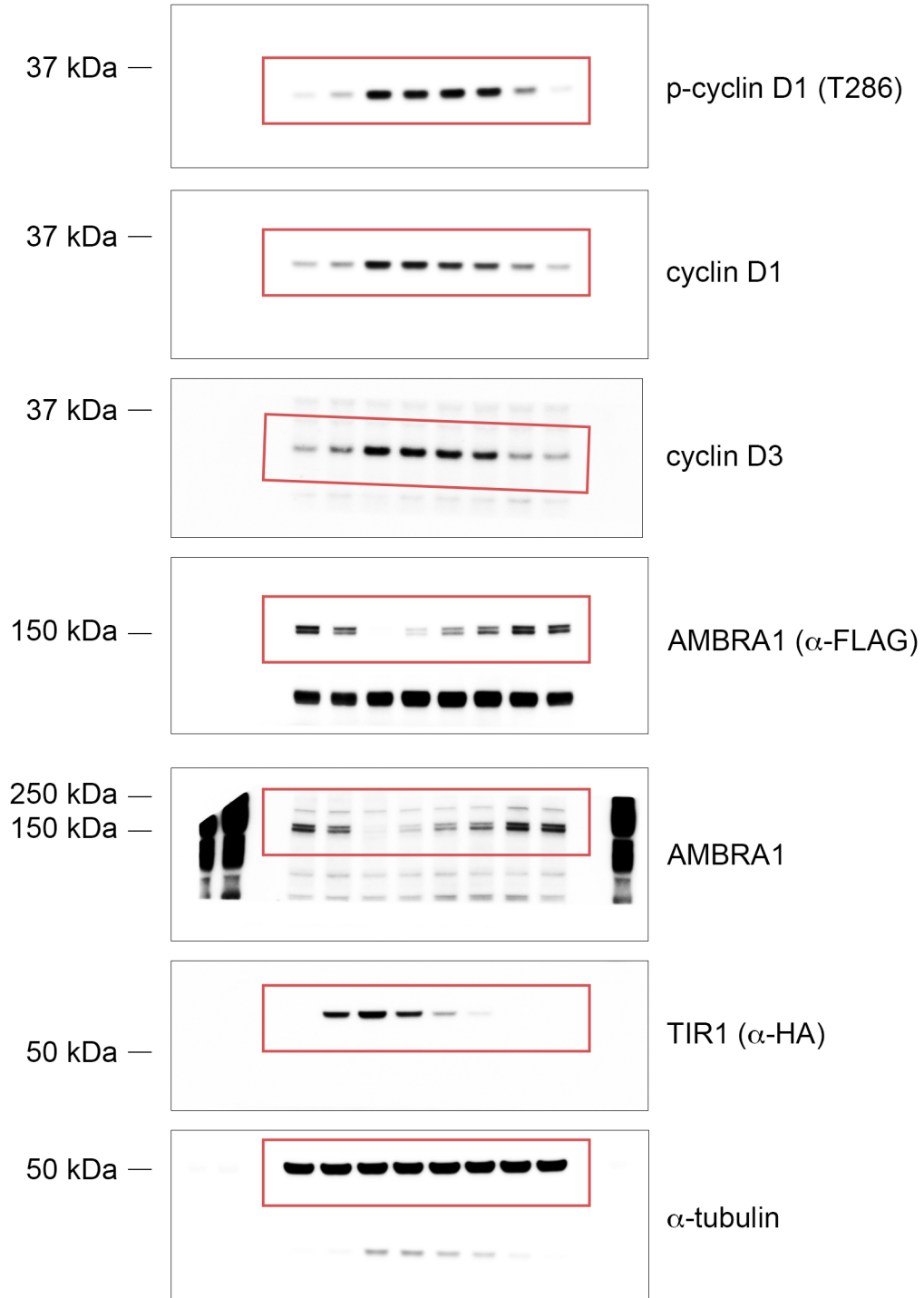
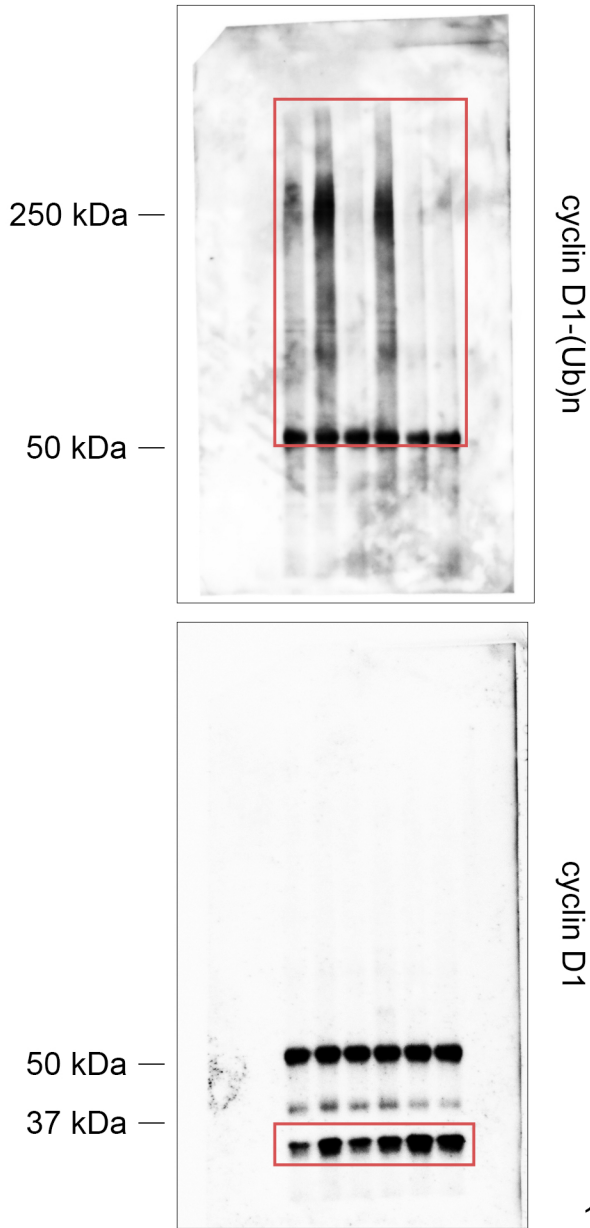

Figure 2d



Extended Data Fig. 3f

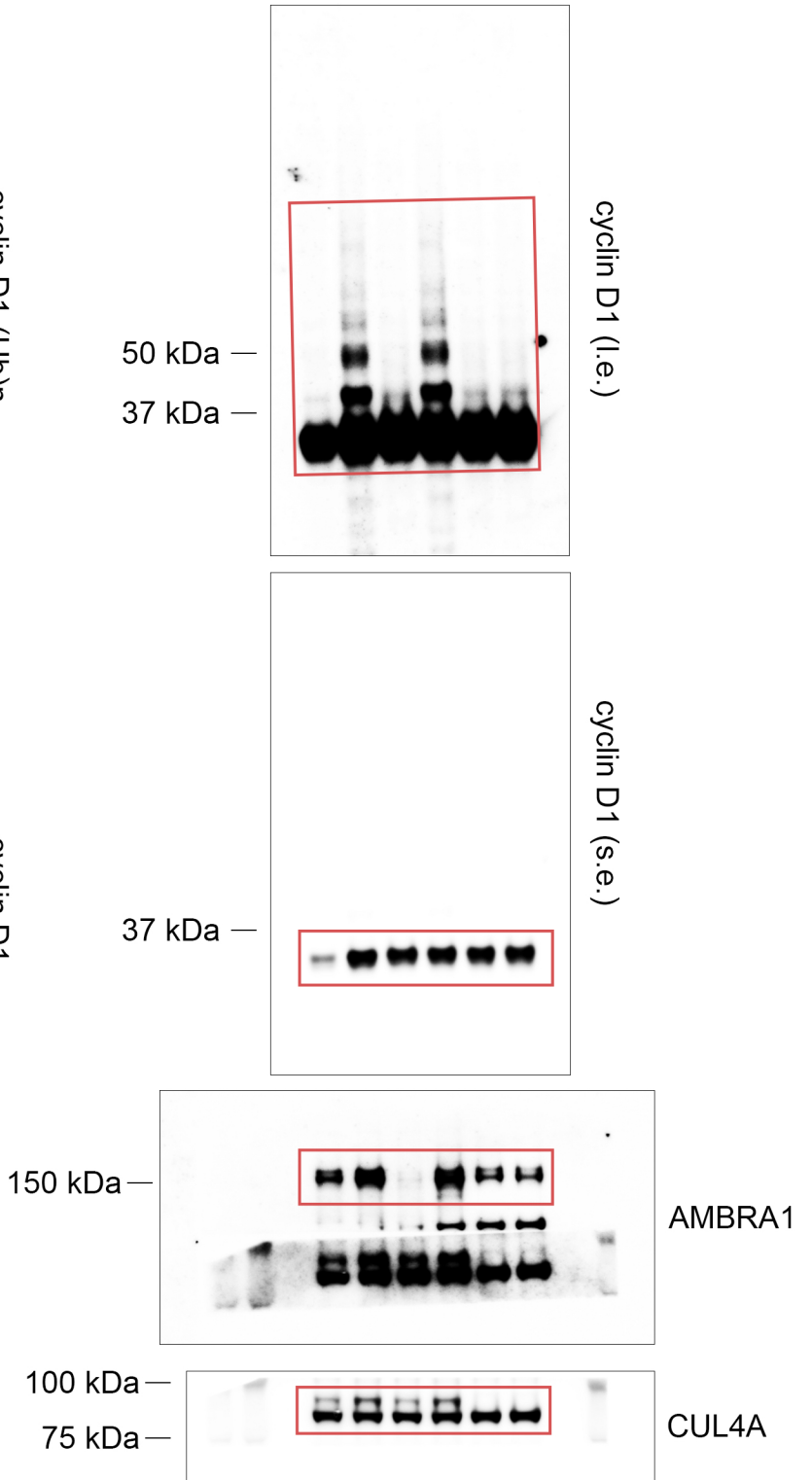

Figure 2f

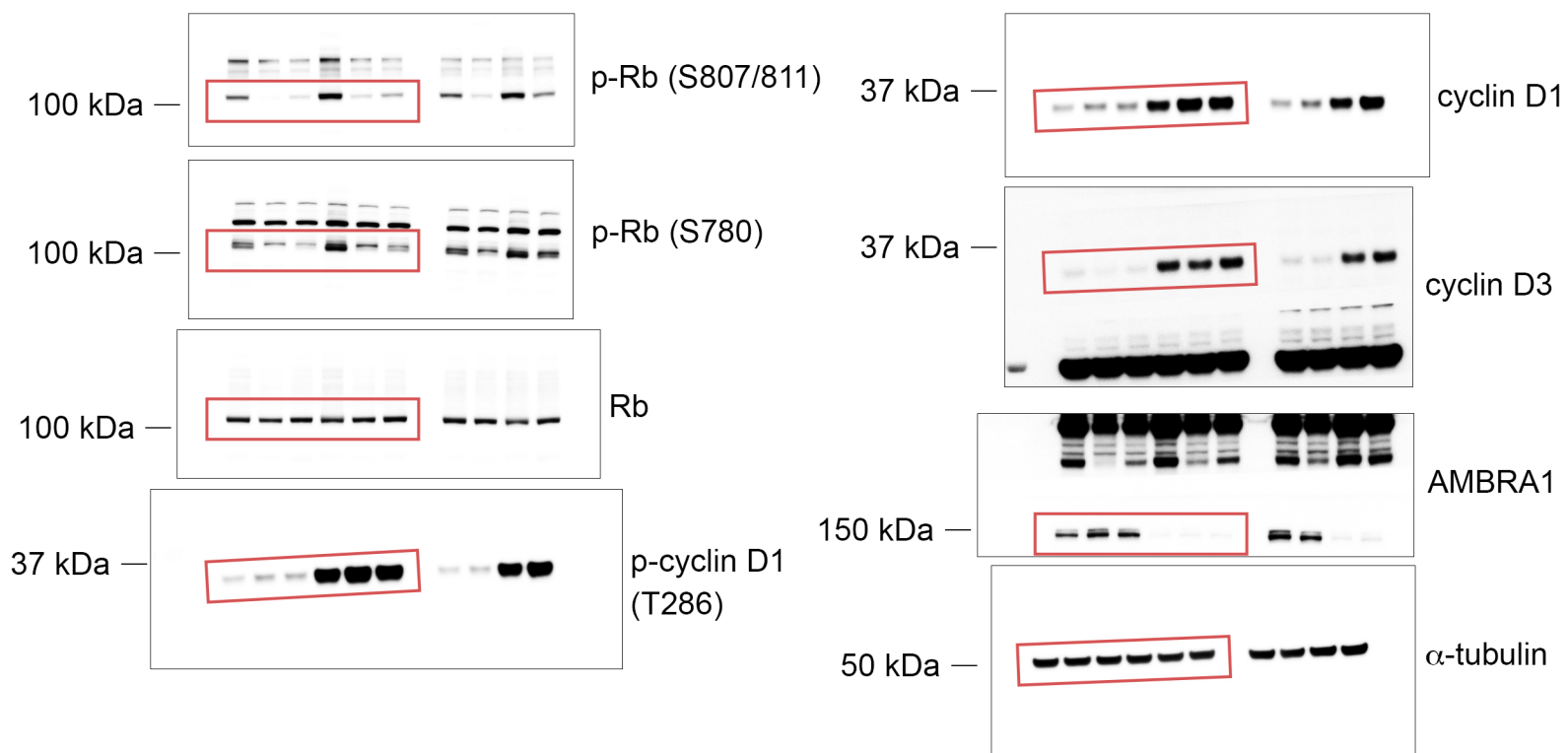
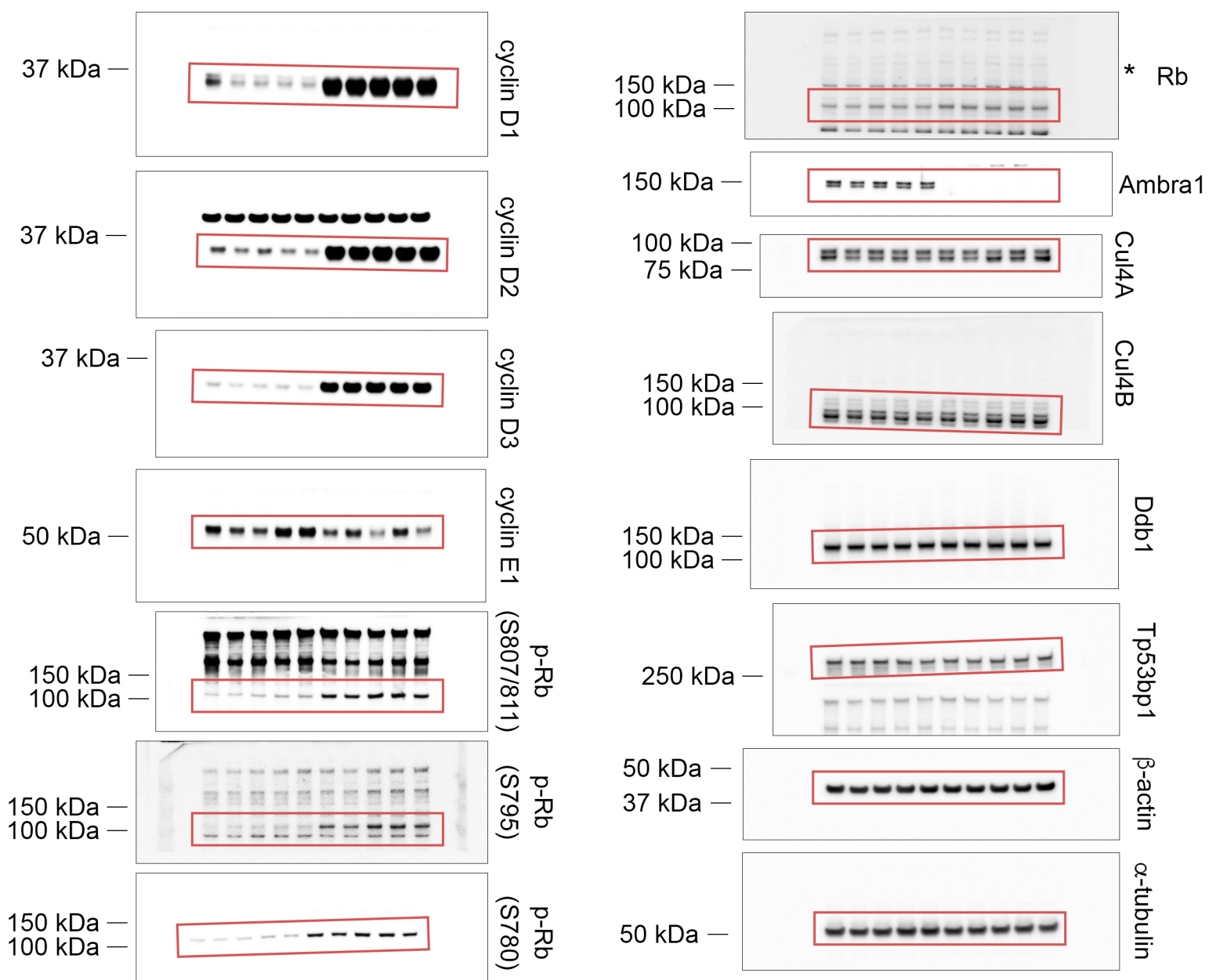
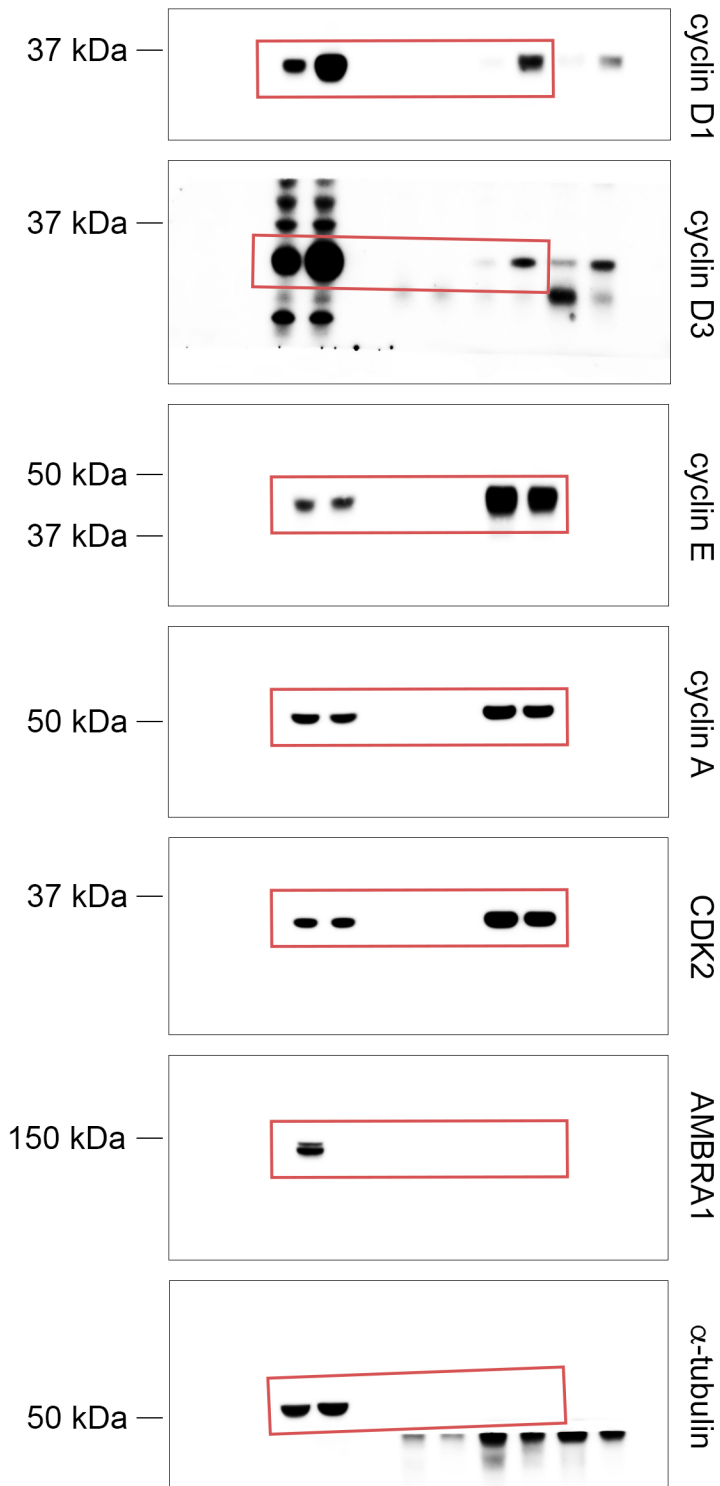

Figure 3a



* Indicates a row of dead pixels from the CCD camera of the chemiluminescent imager

Figure 4a



Extended Data Figure 11j

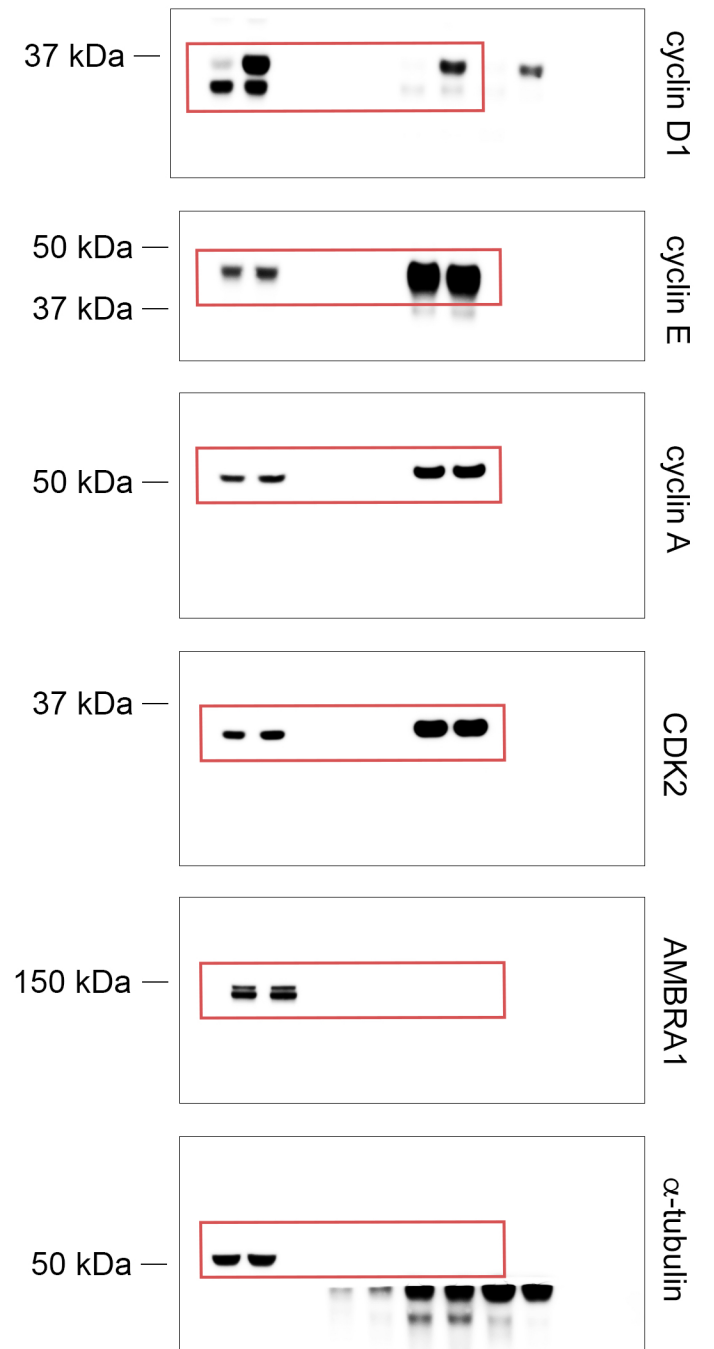
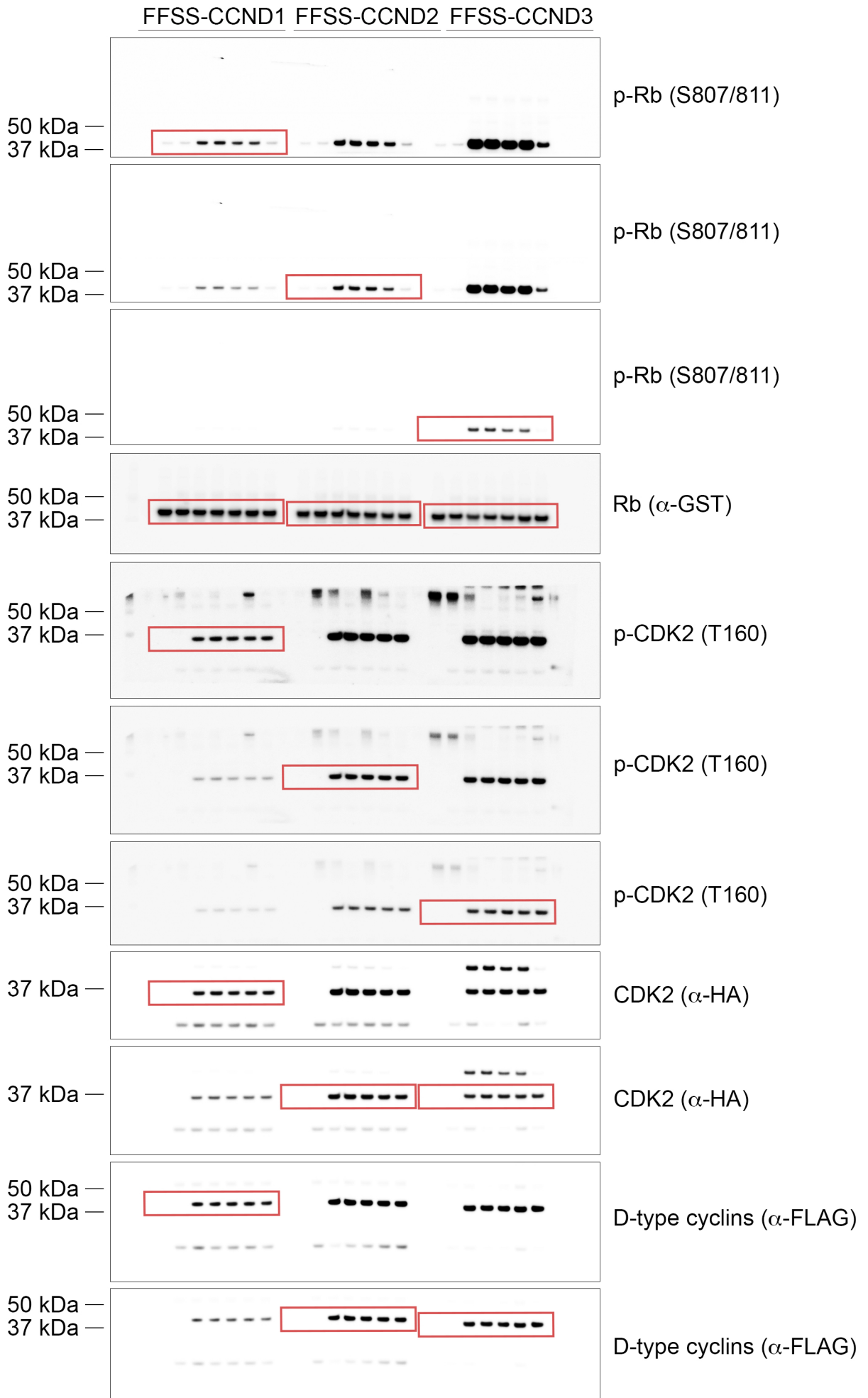
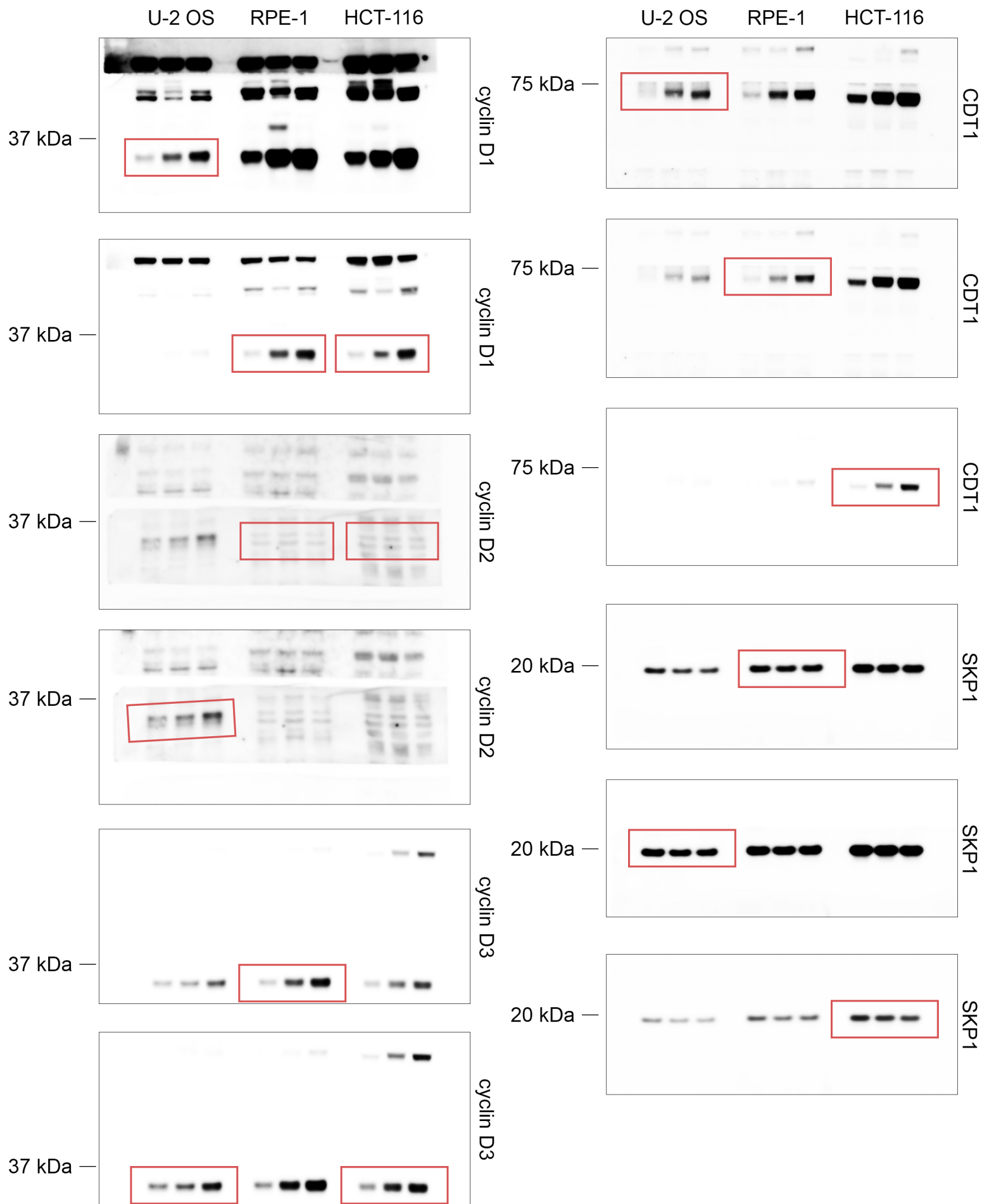

Figure 4b and Extended Data Figure 12a



Extended Data Figure 1a



Extended Data Figure 1b

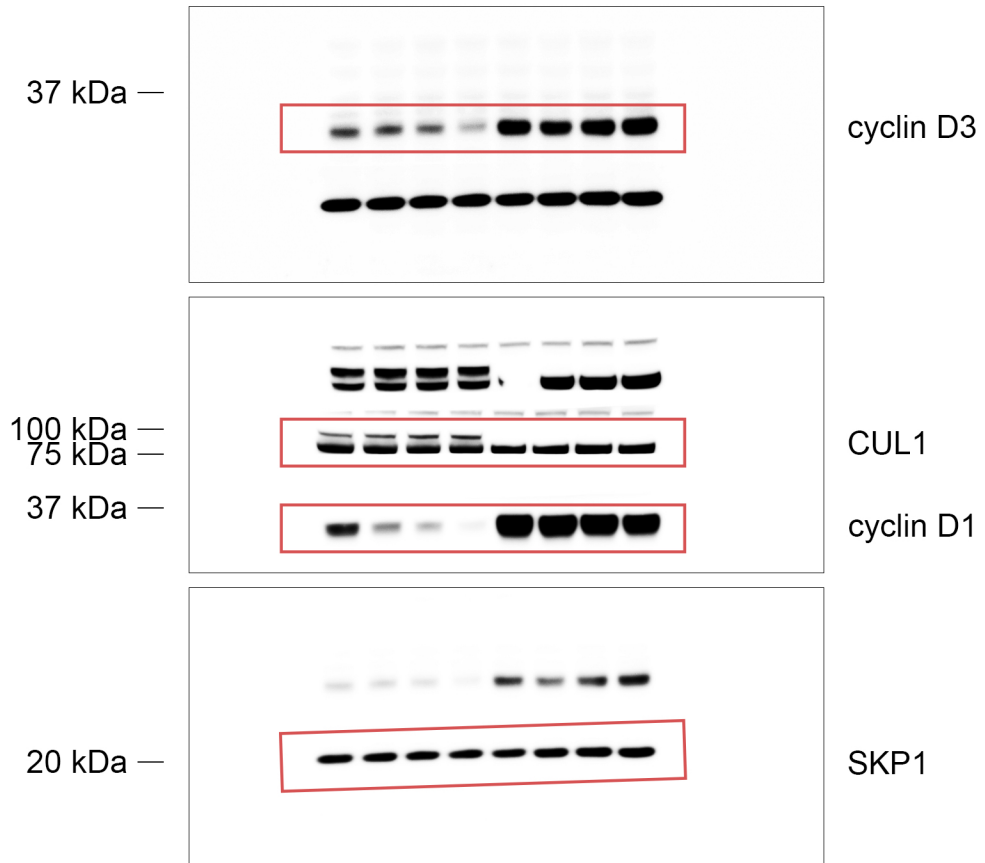

Extended Data Figure 1c

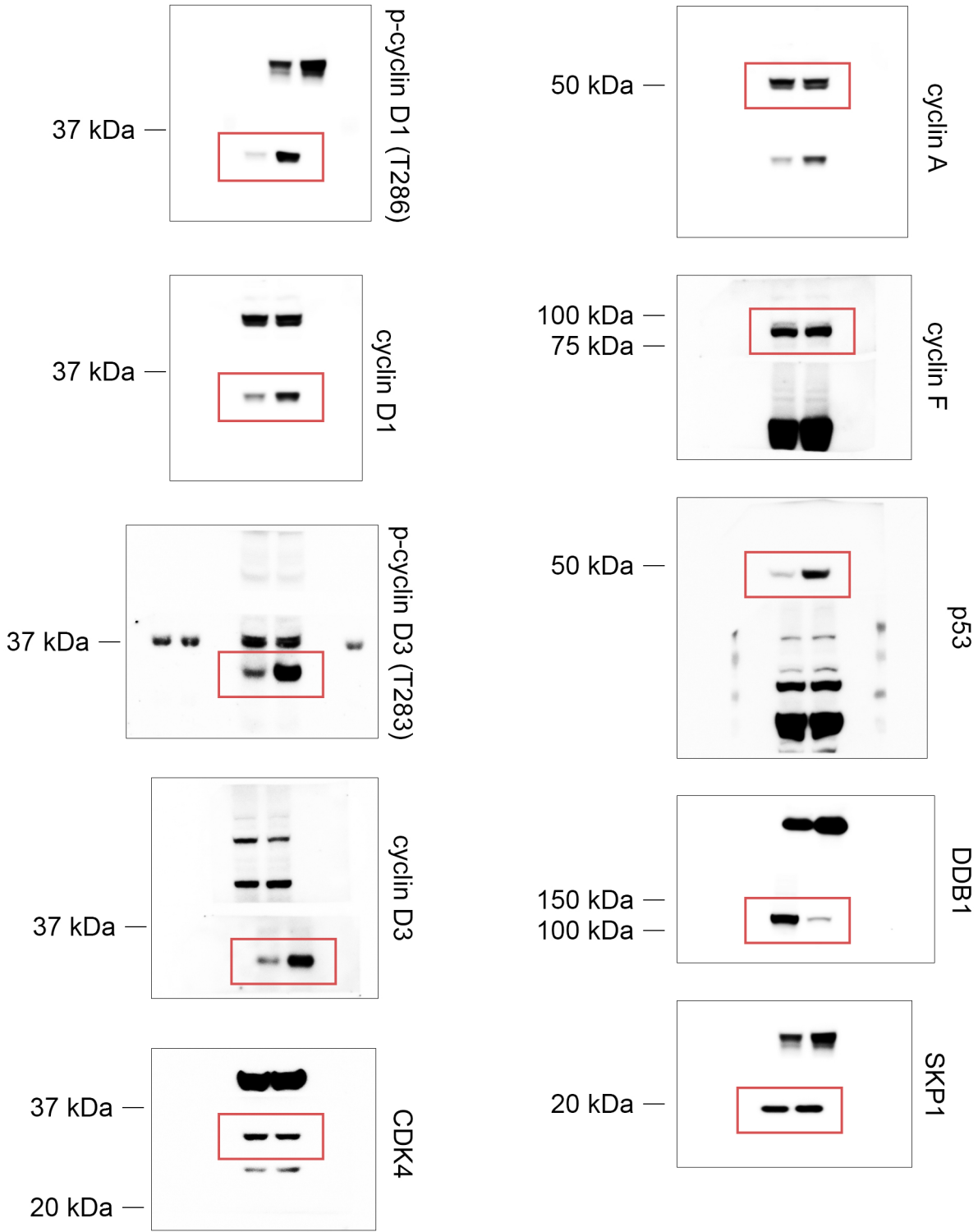

Extended Data Figure 1d

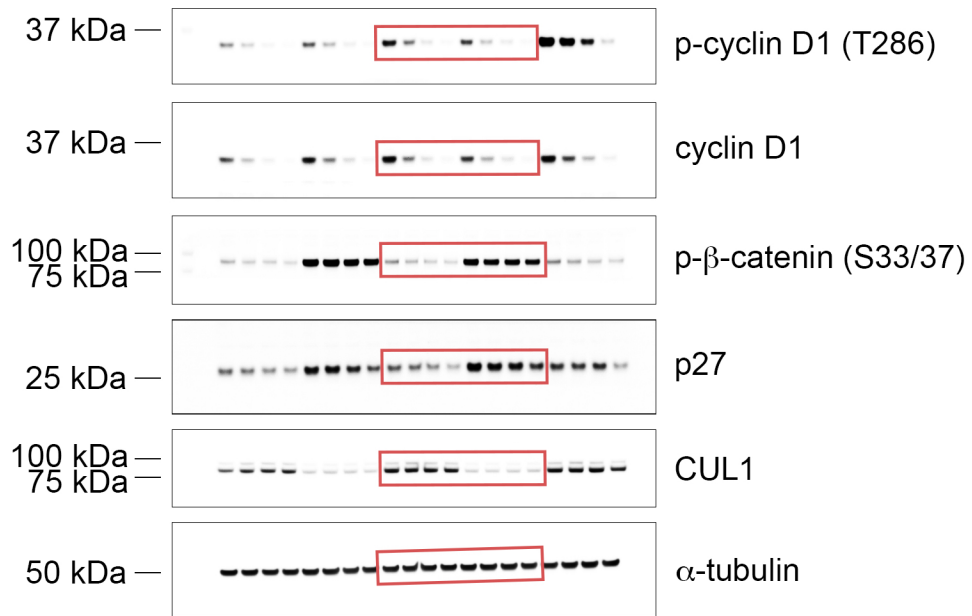

Extended Data Figure 1e



Extended Data Figure 1f

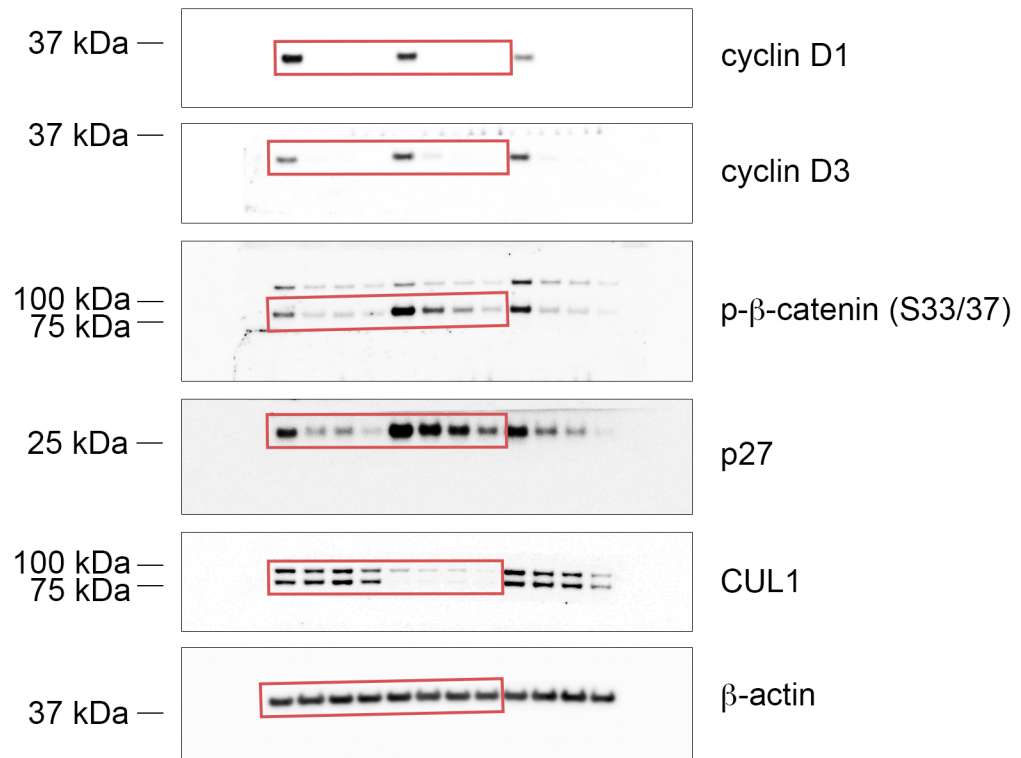

Extended Data Figure 1g

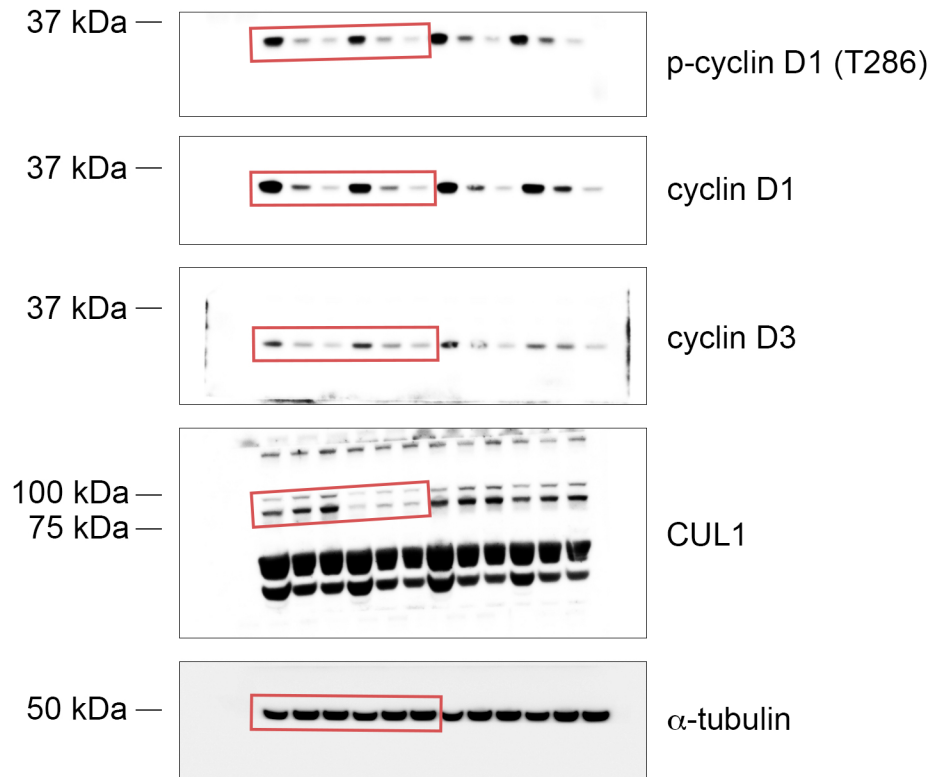

Extended Data Figure 1h

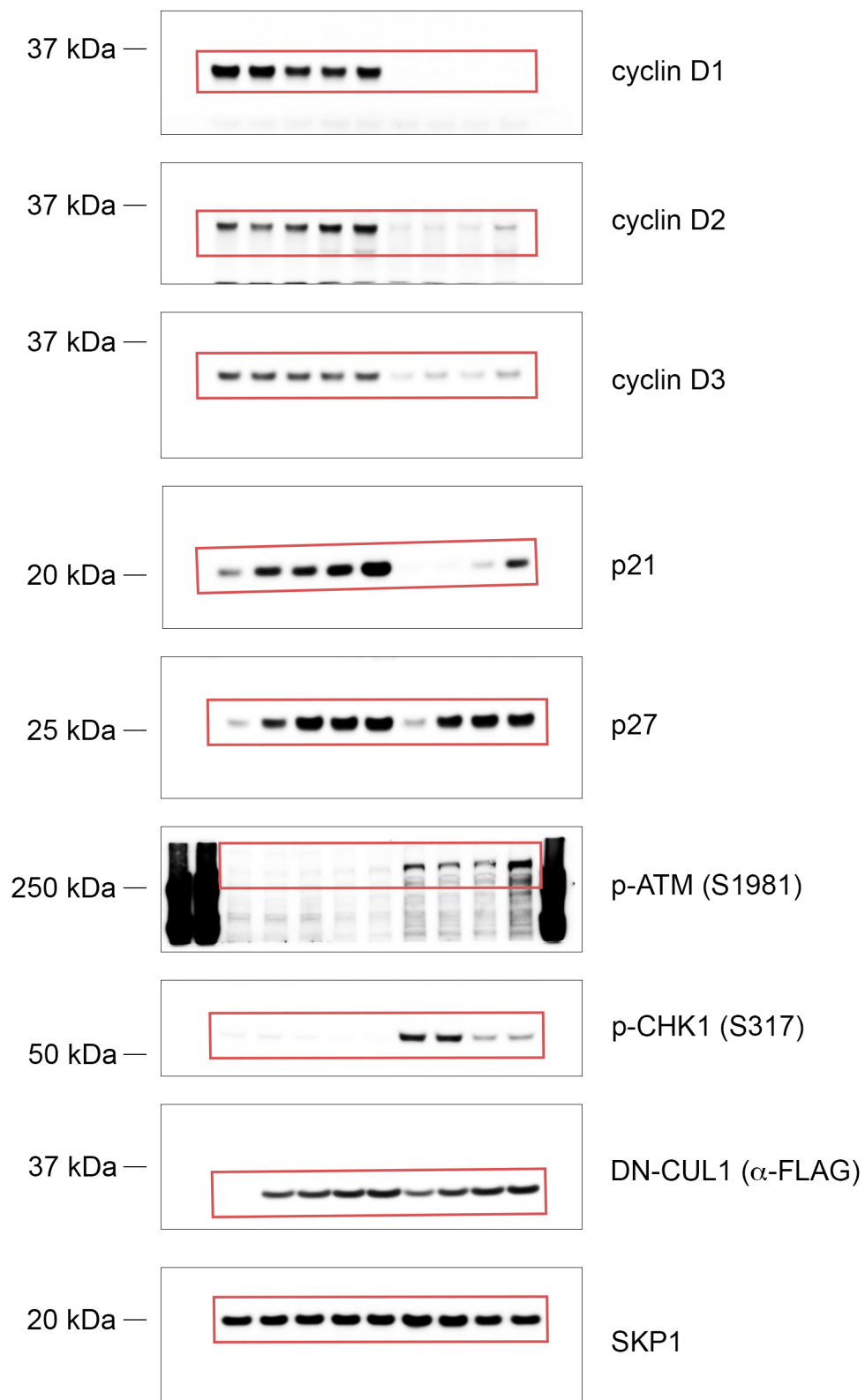

Extended Data Figure 2a

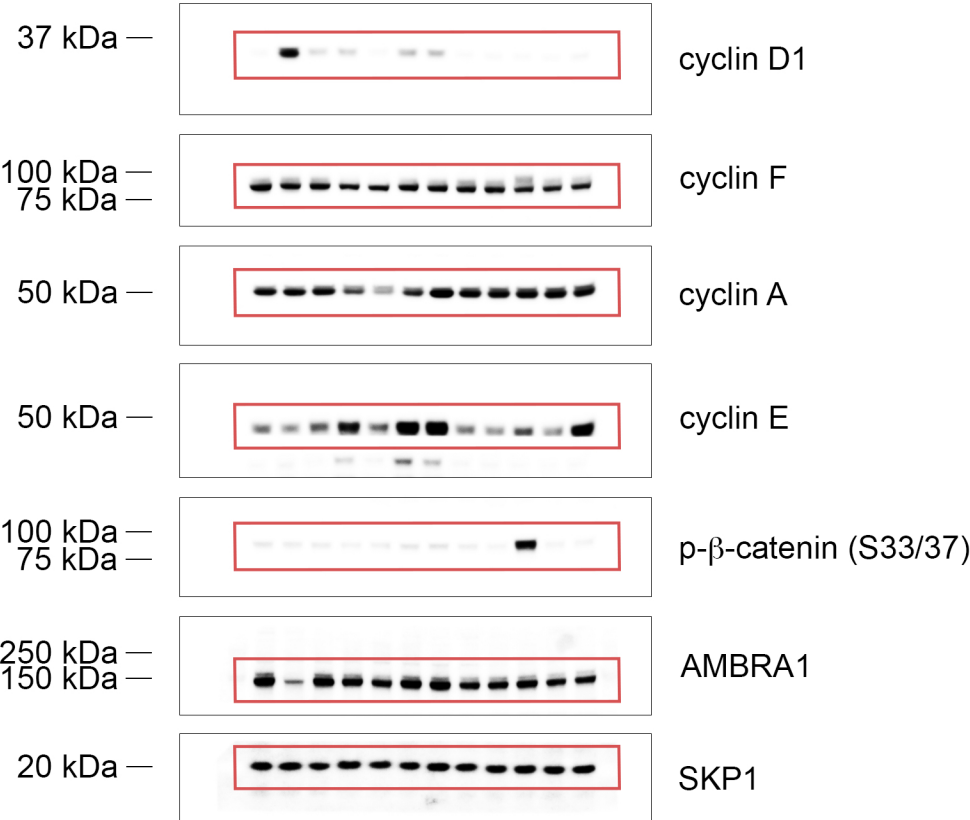

Extended Data Figure 2b

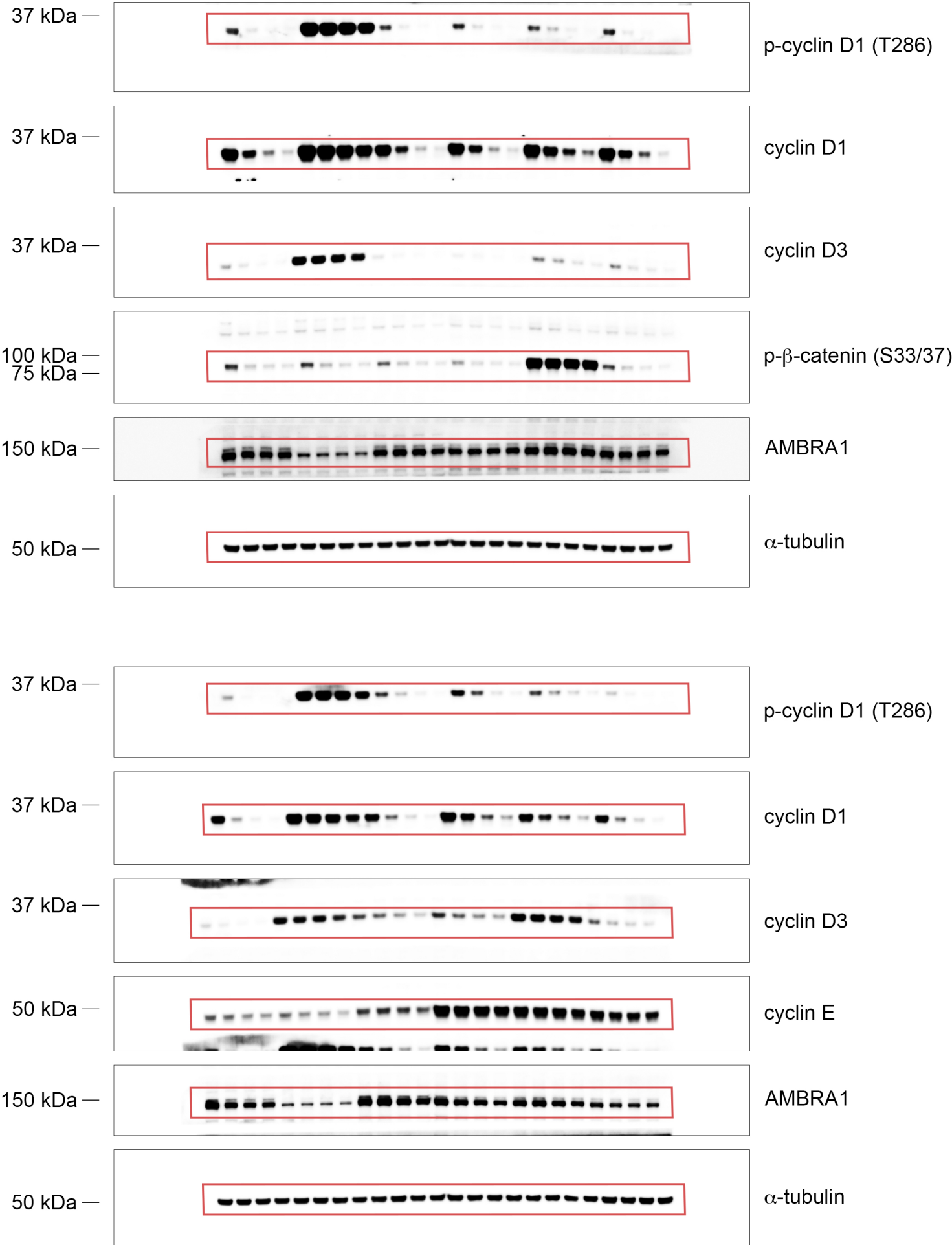

Extended Data Figure 2c

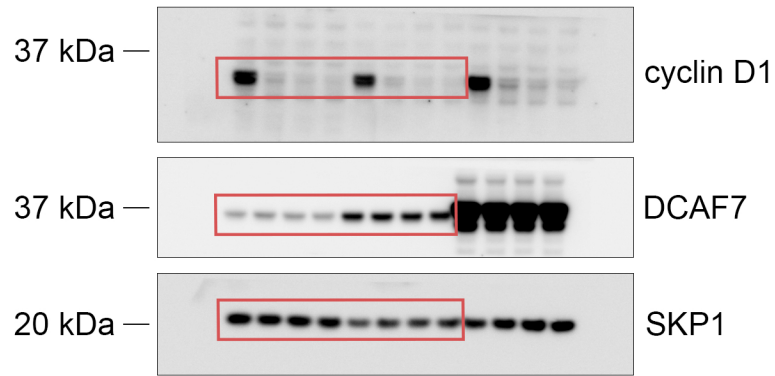

Extended Data Figure 2d

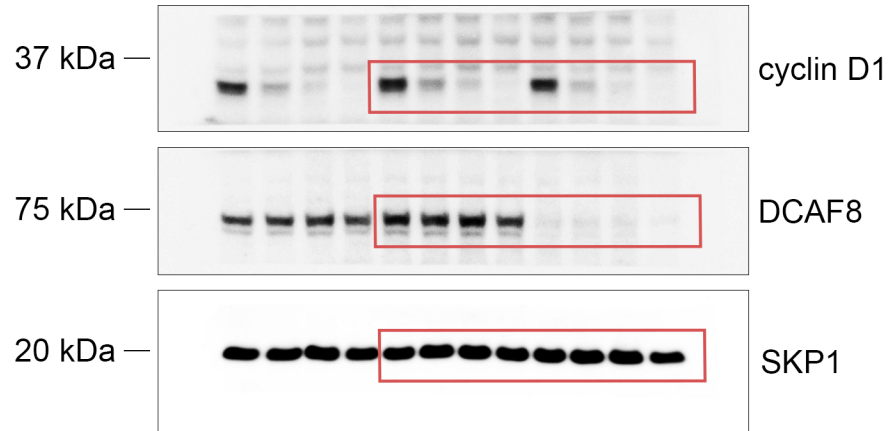

Extended Data Figure 2e

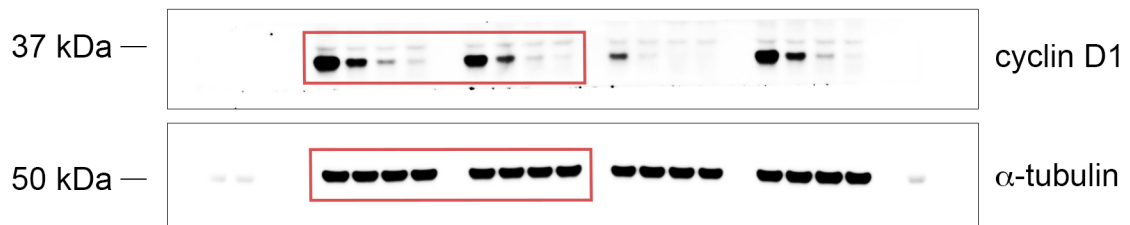

Extended Data Figure 2f

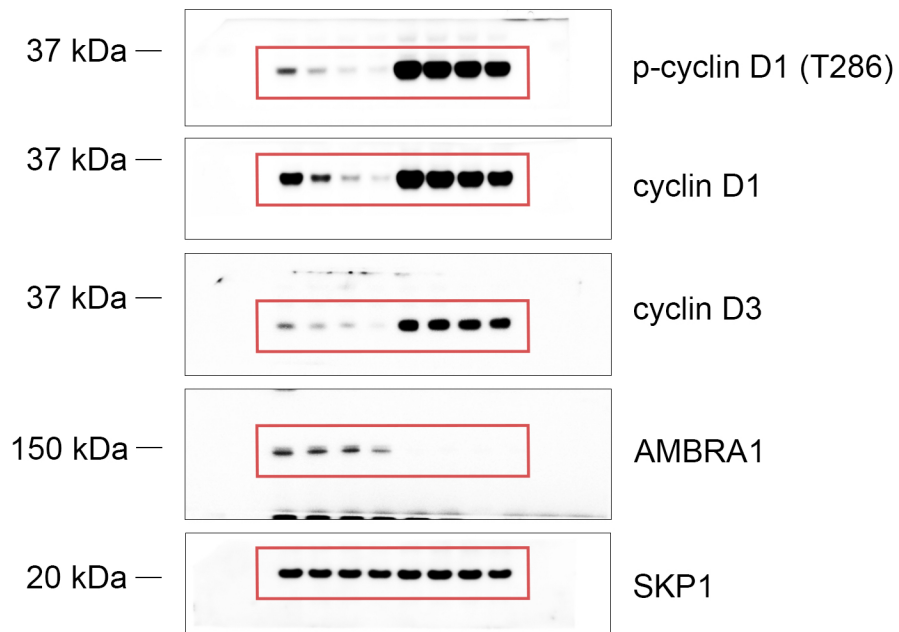

Extended Data Figure 2g

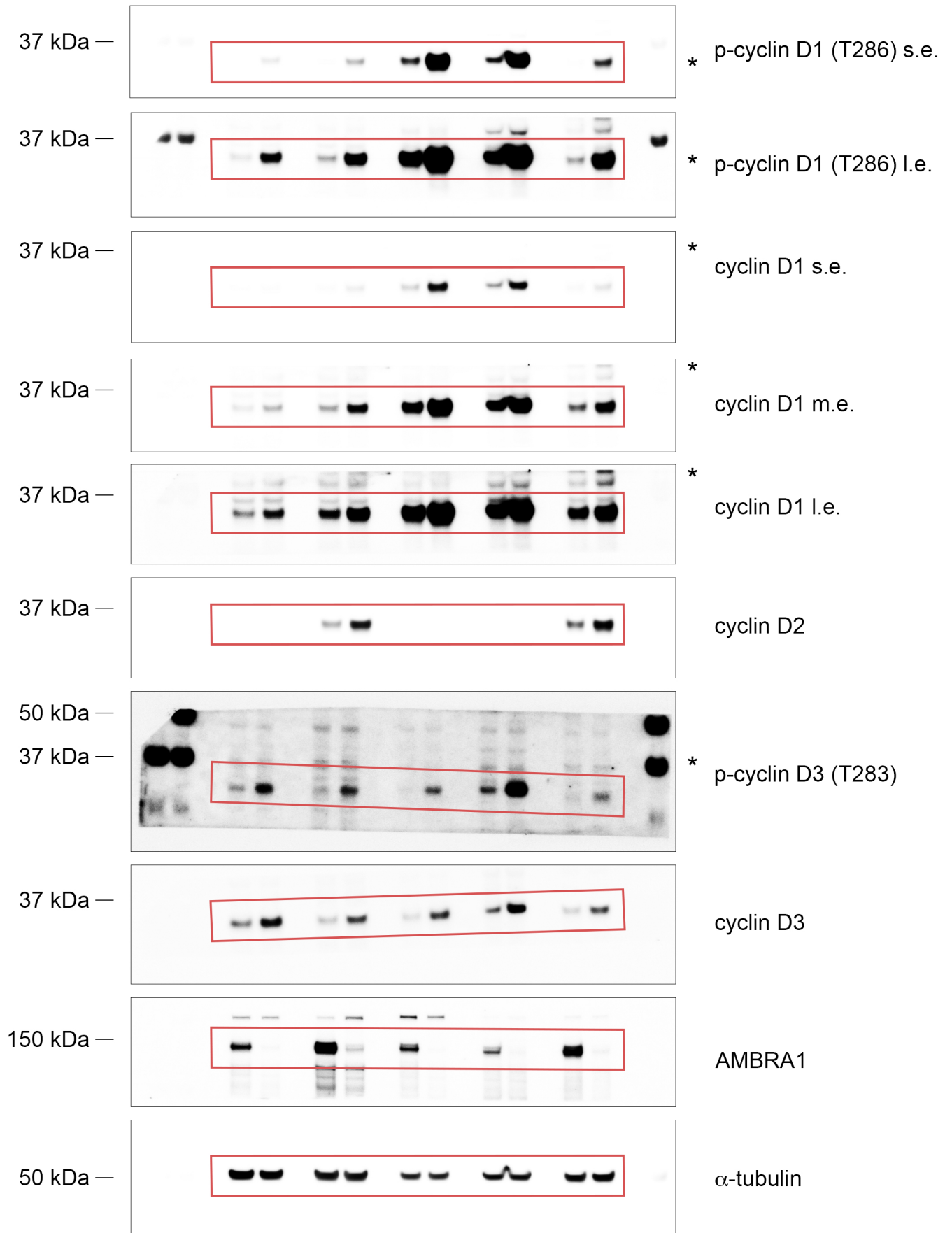

* Indicates a row of dead pixels from the CCD camera of the chemiluminescent imager

Extended Data Figure 2i

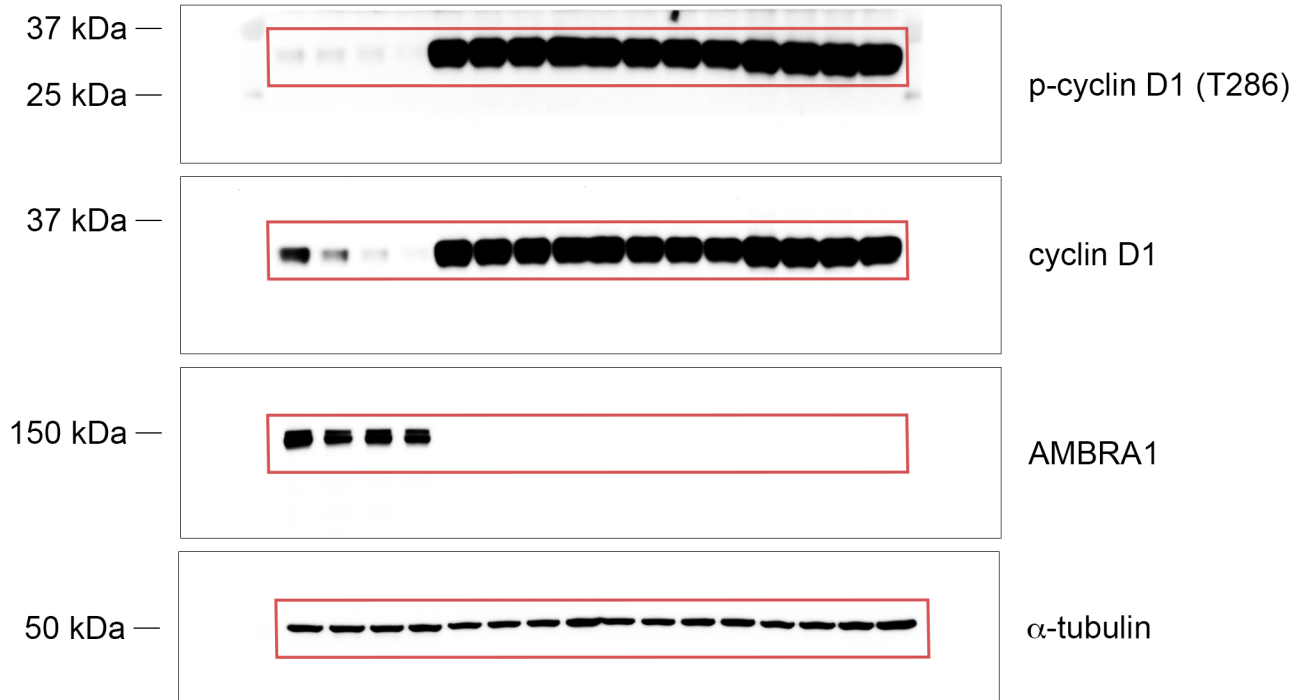

Extended Data Figure 2j

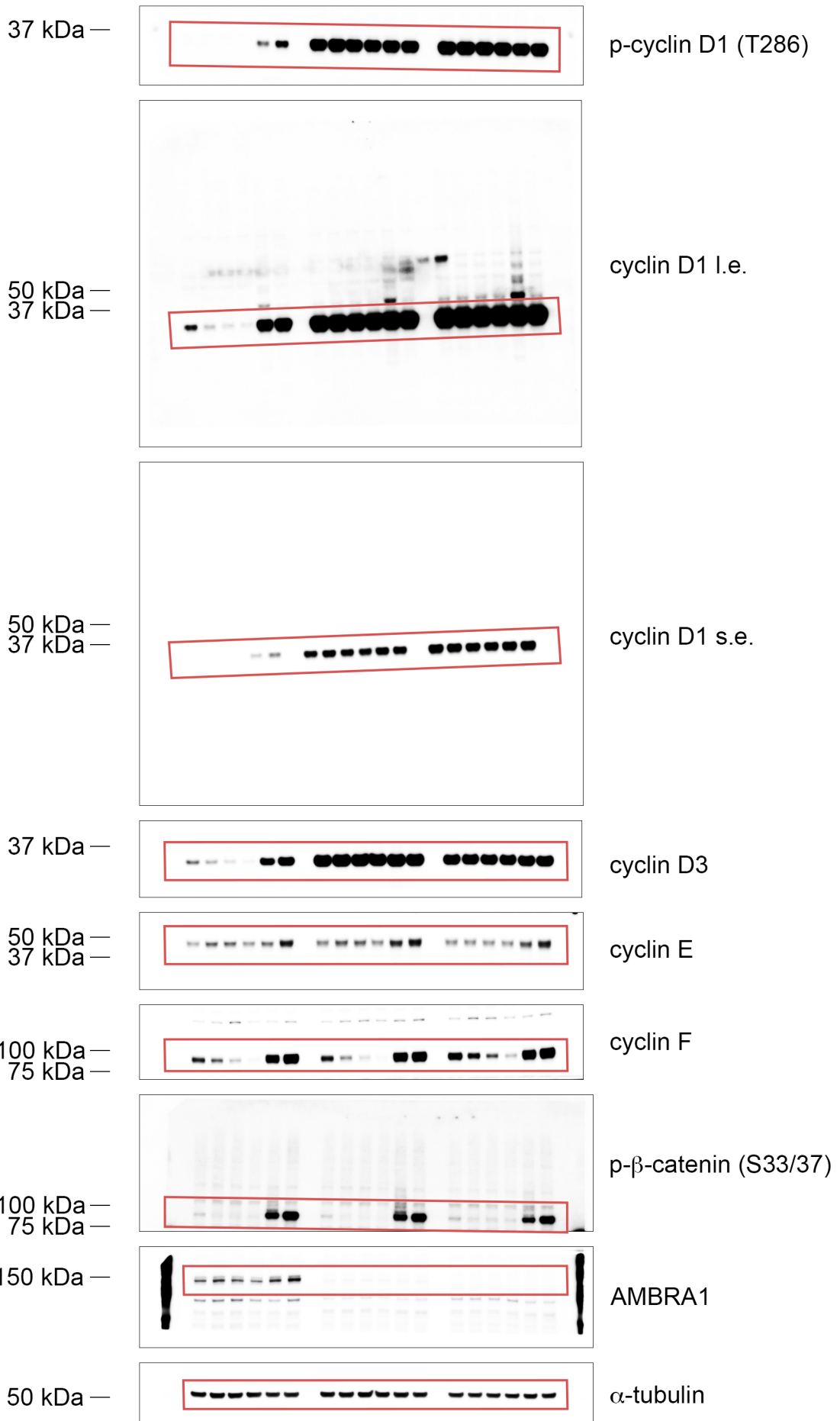

Extended Data Figure 2k

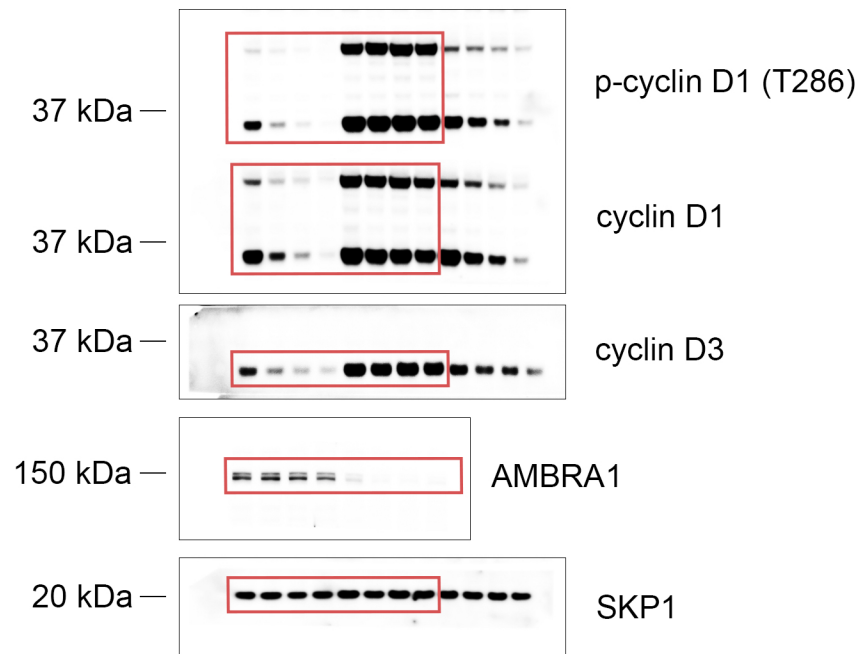

Extended Data Figure 2l

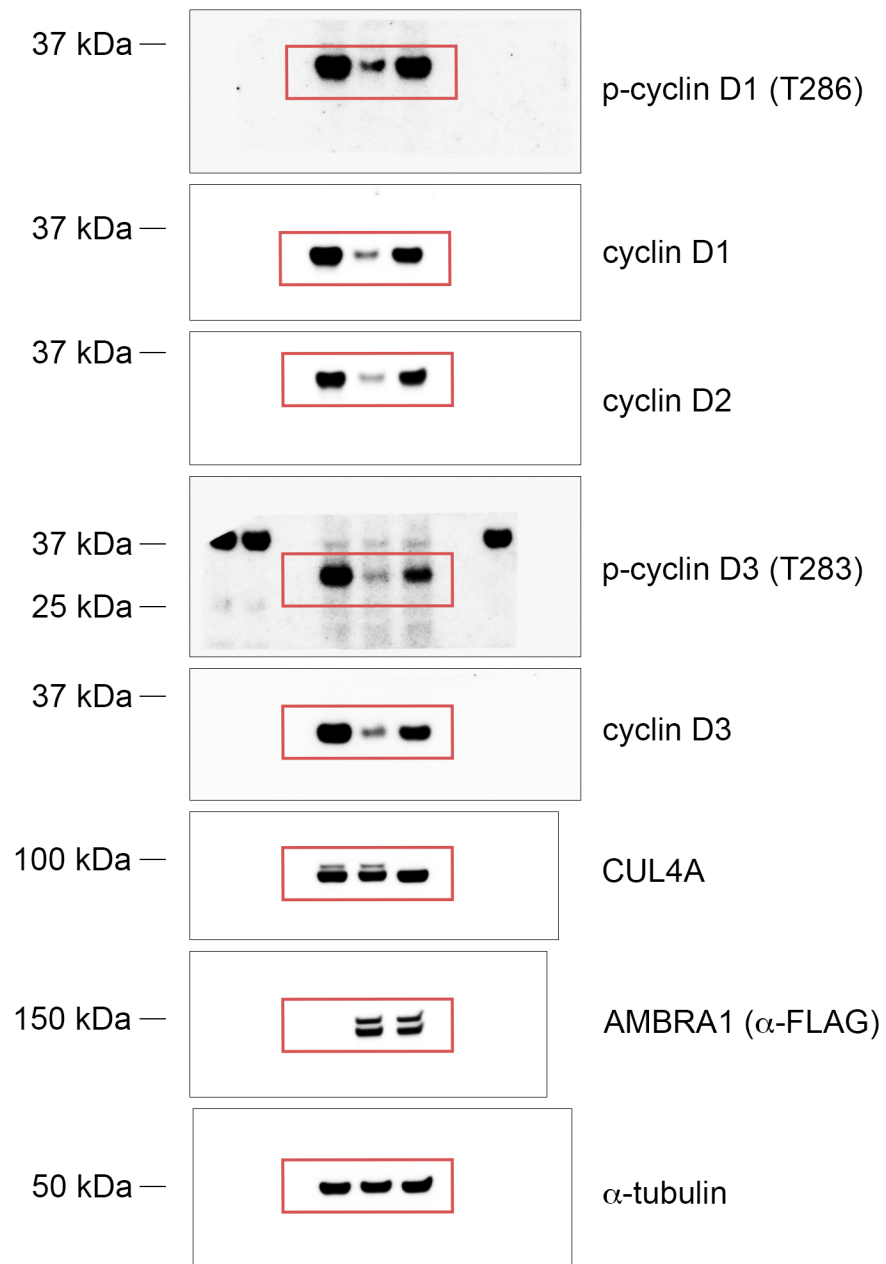

Extended Data Figure 3b

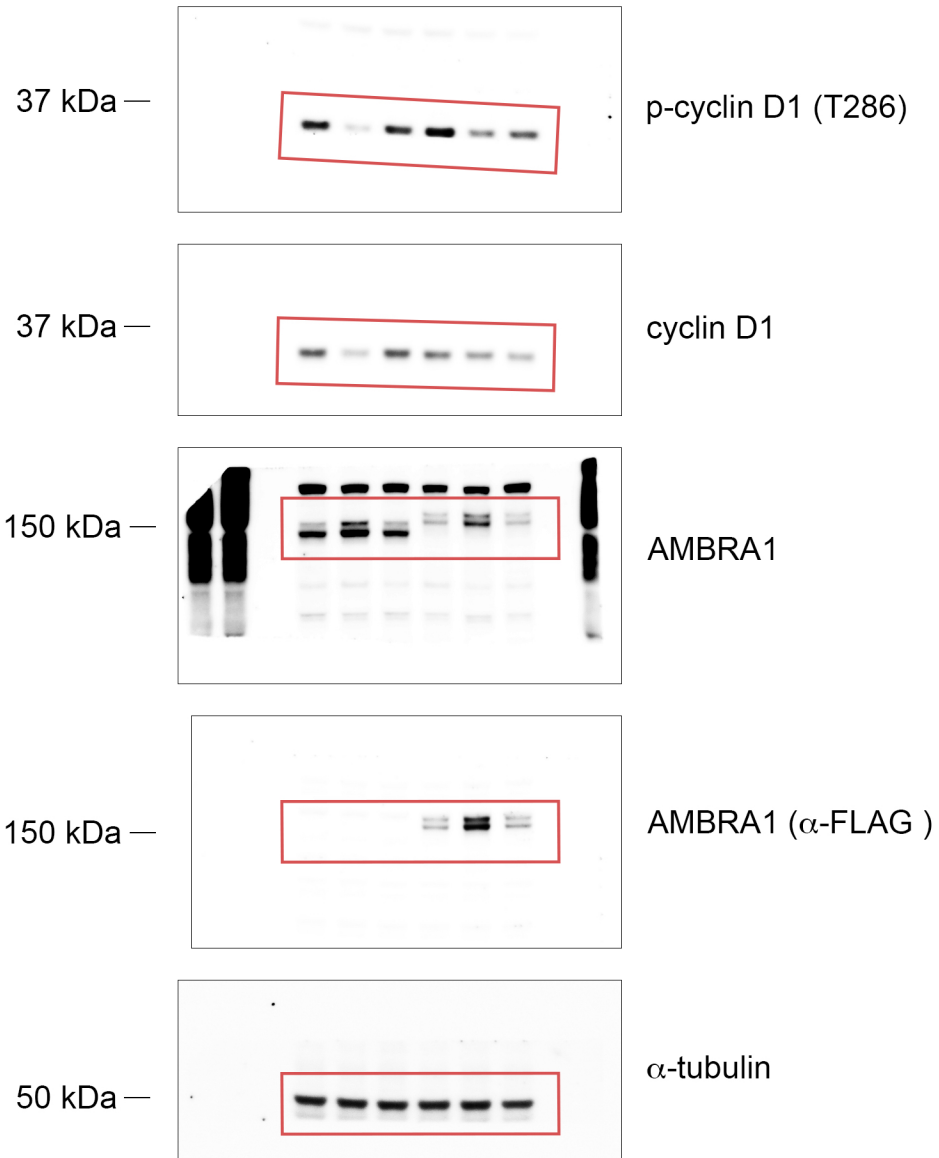

Extended Data Figure 3c

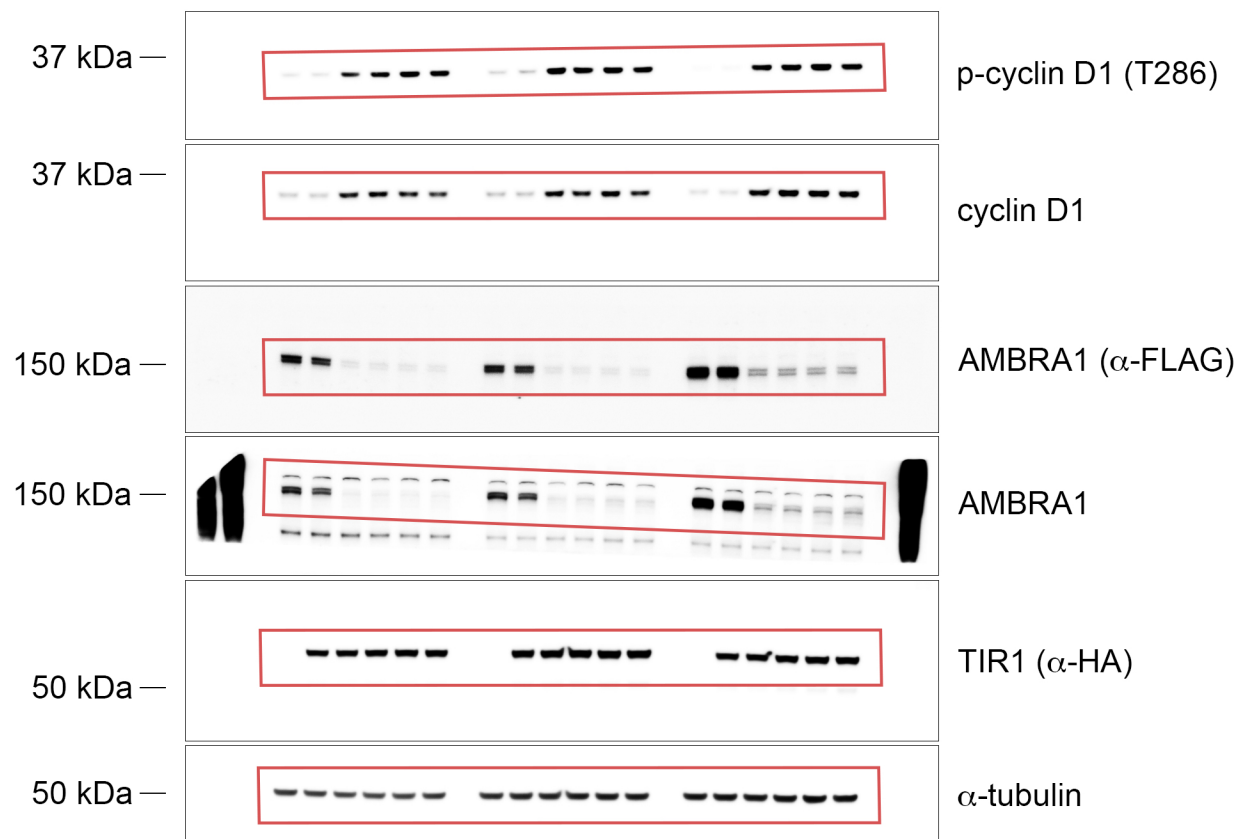

Extended Data Figure 3d

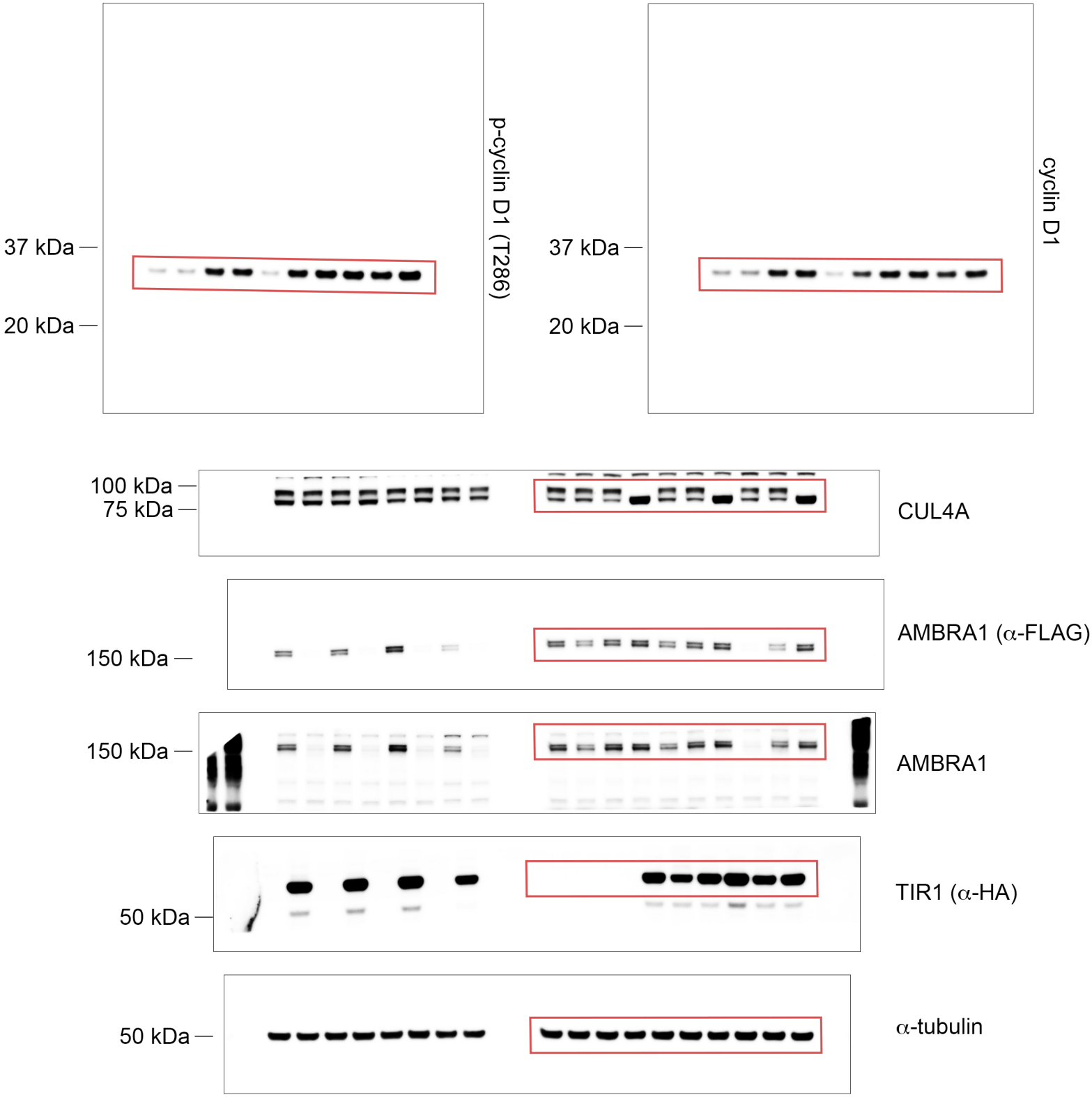

Extended Data Figure 3e

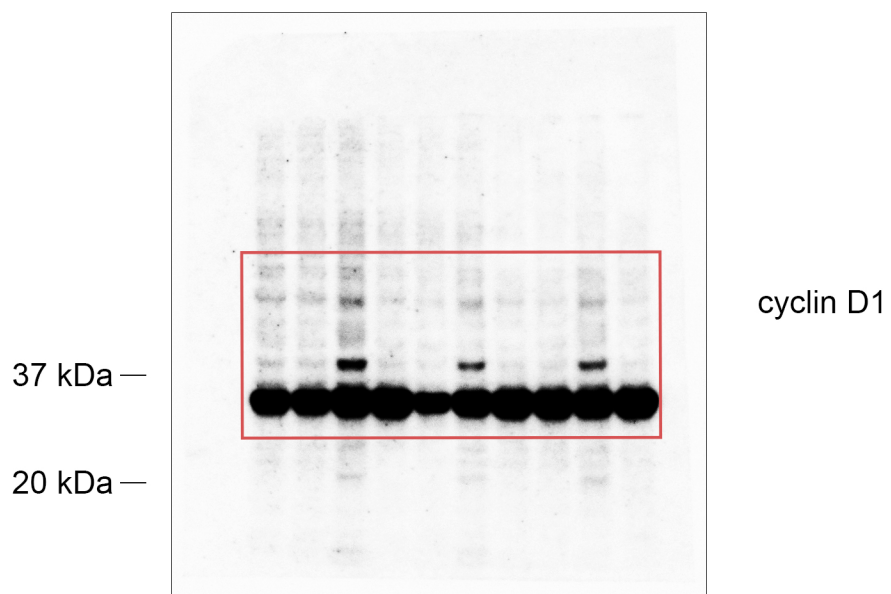
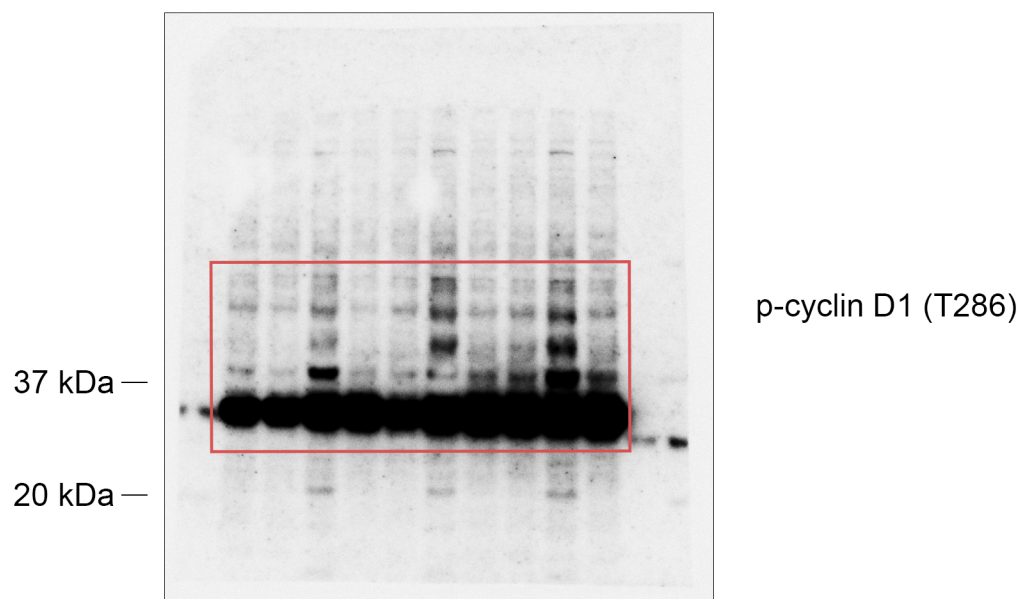

Extended Data Figure 3f - See above

Extended Data Figure 4c

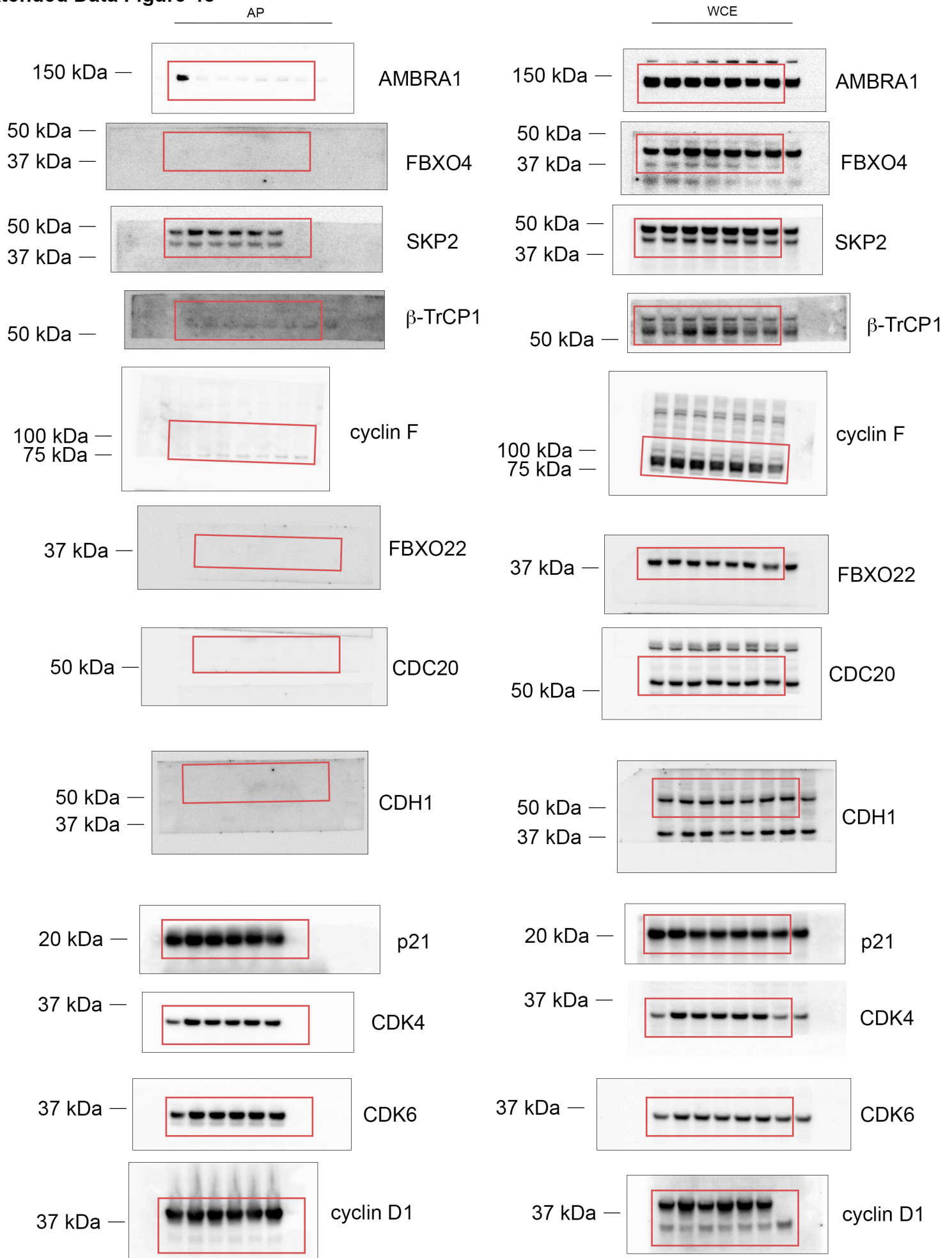

Extended Data Figure 4d

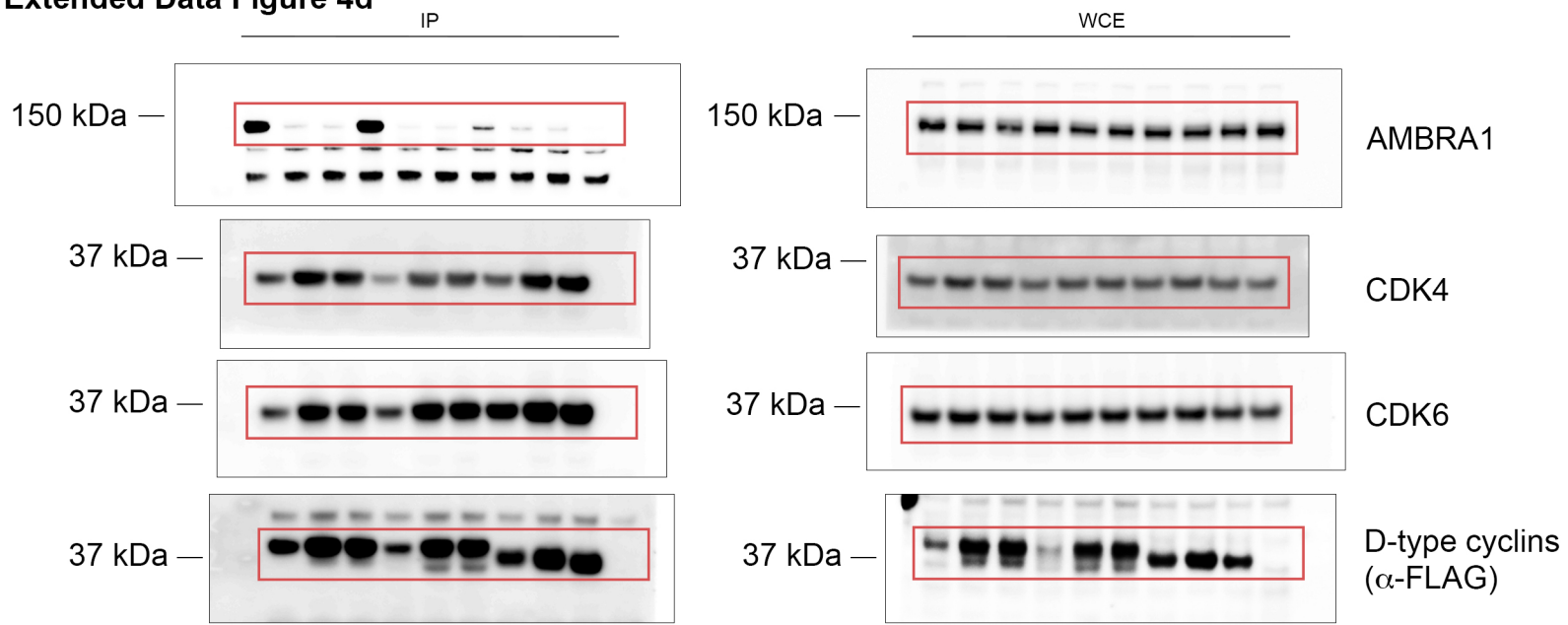

Extended Data Figure 4k

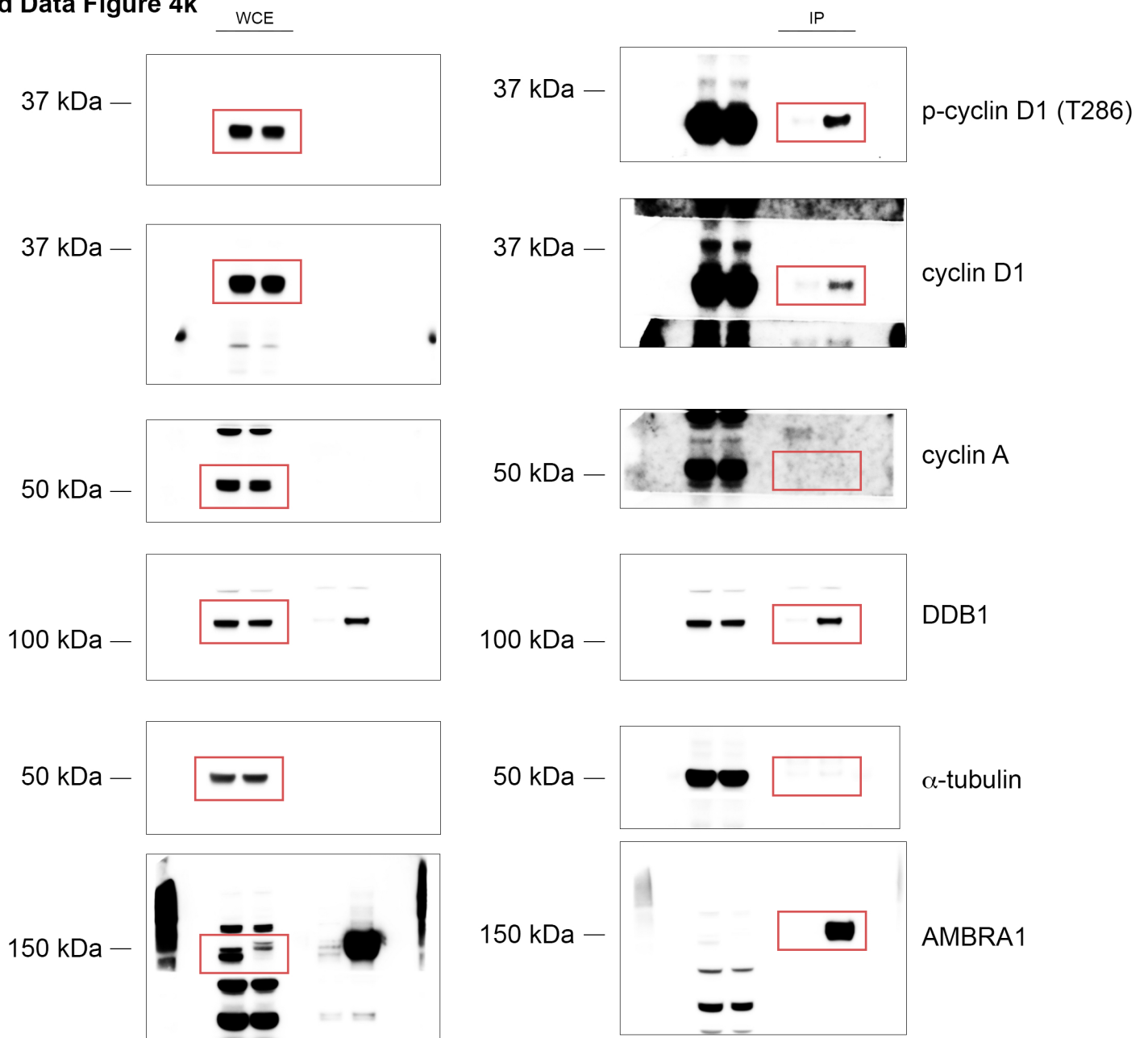

Extended Data Figure 4e

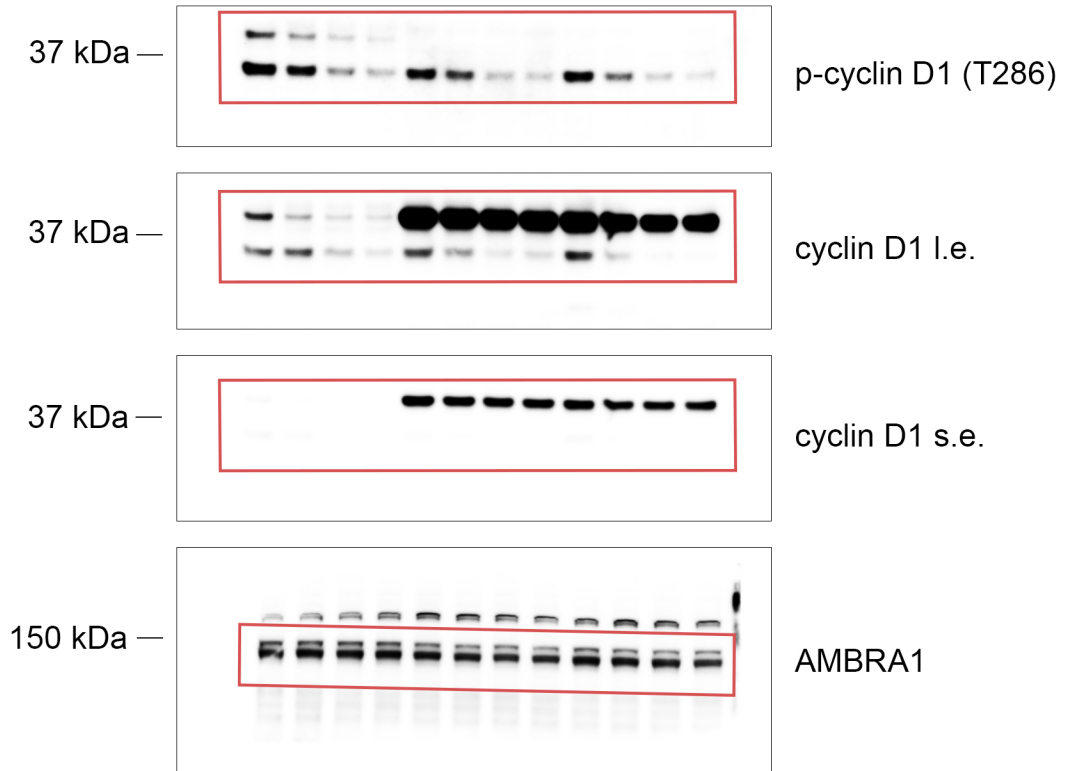

Extended Data Figure 4f

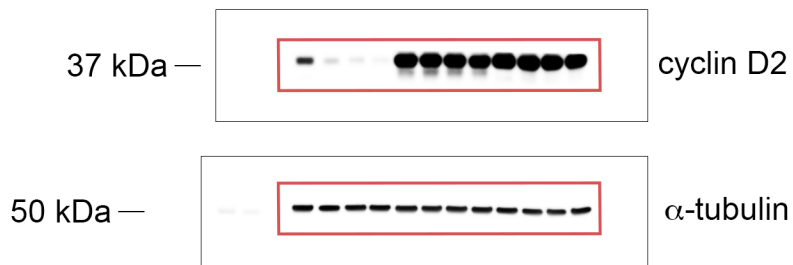

Extended Data Figure 4g

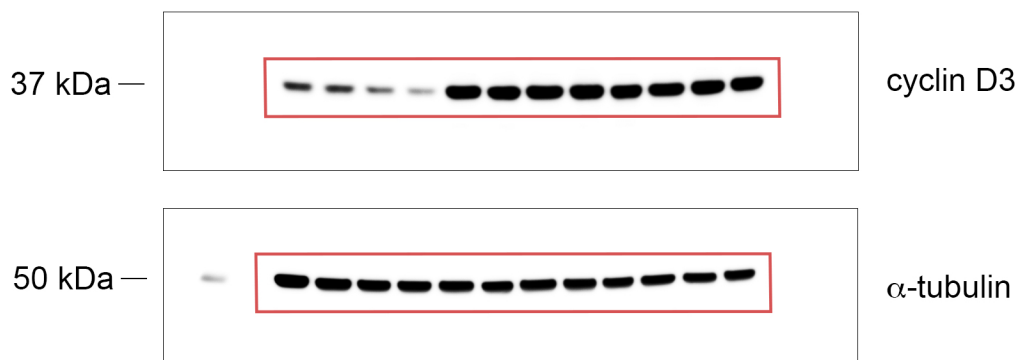

Extended Data Figure 4h

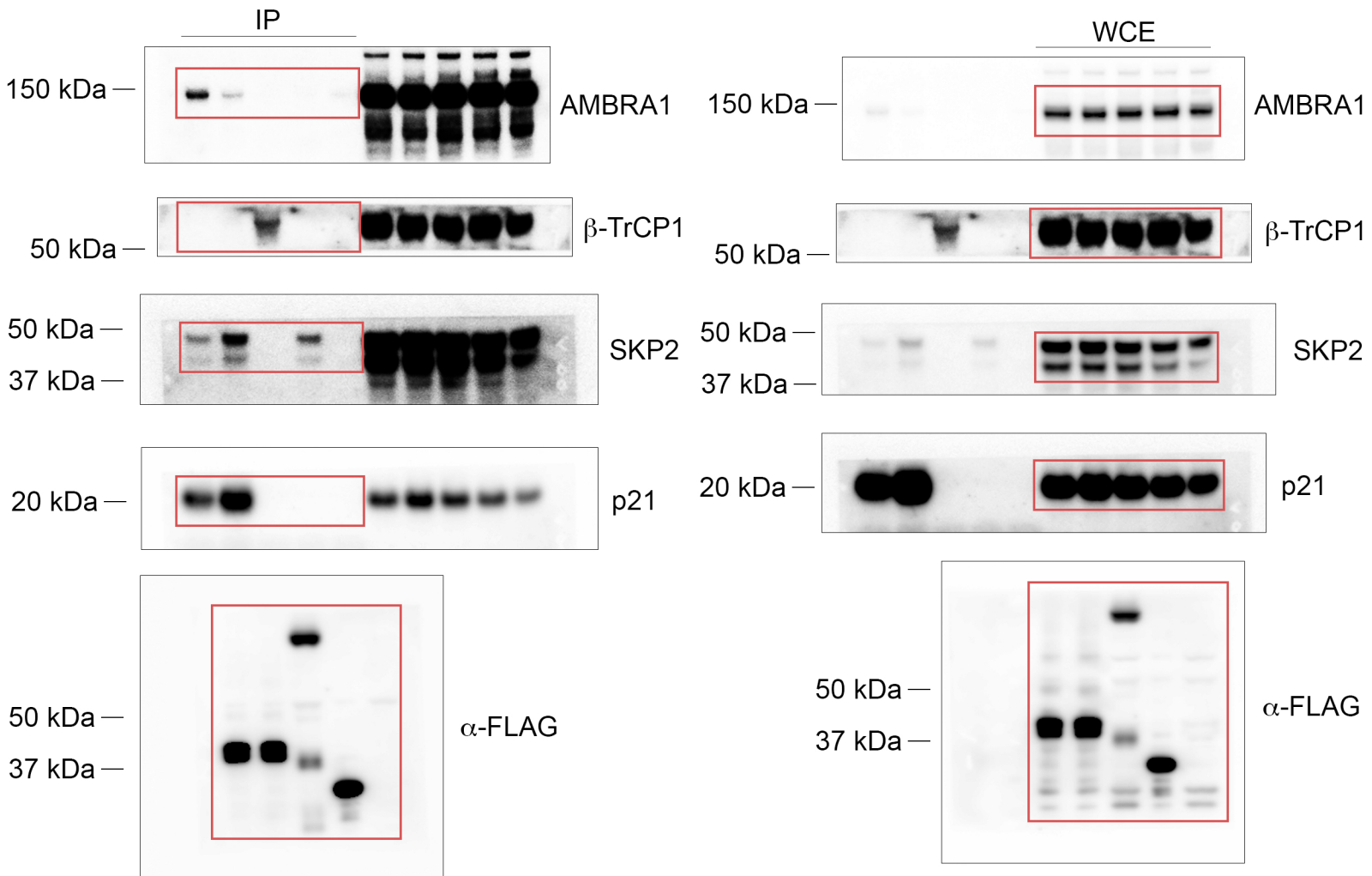

Extended Data Figure 4i

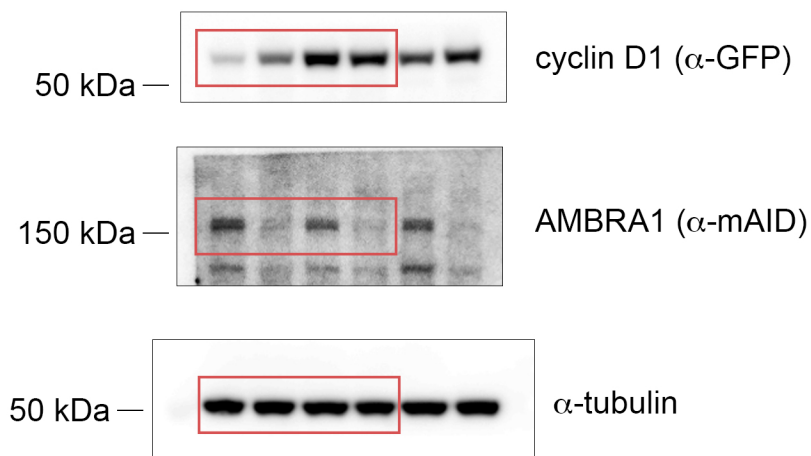

Extended Data Figure 4i

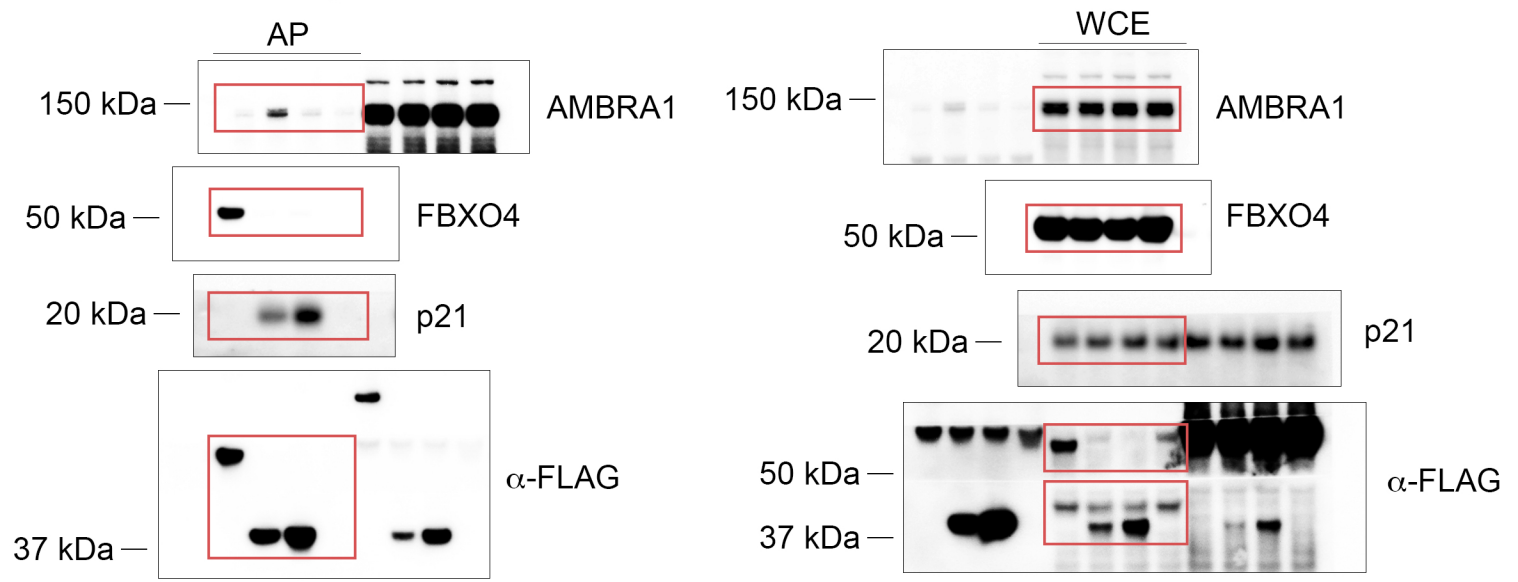

Extended Data Figure 4j

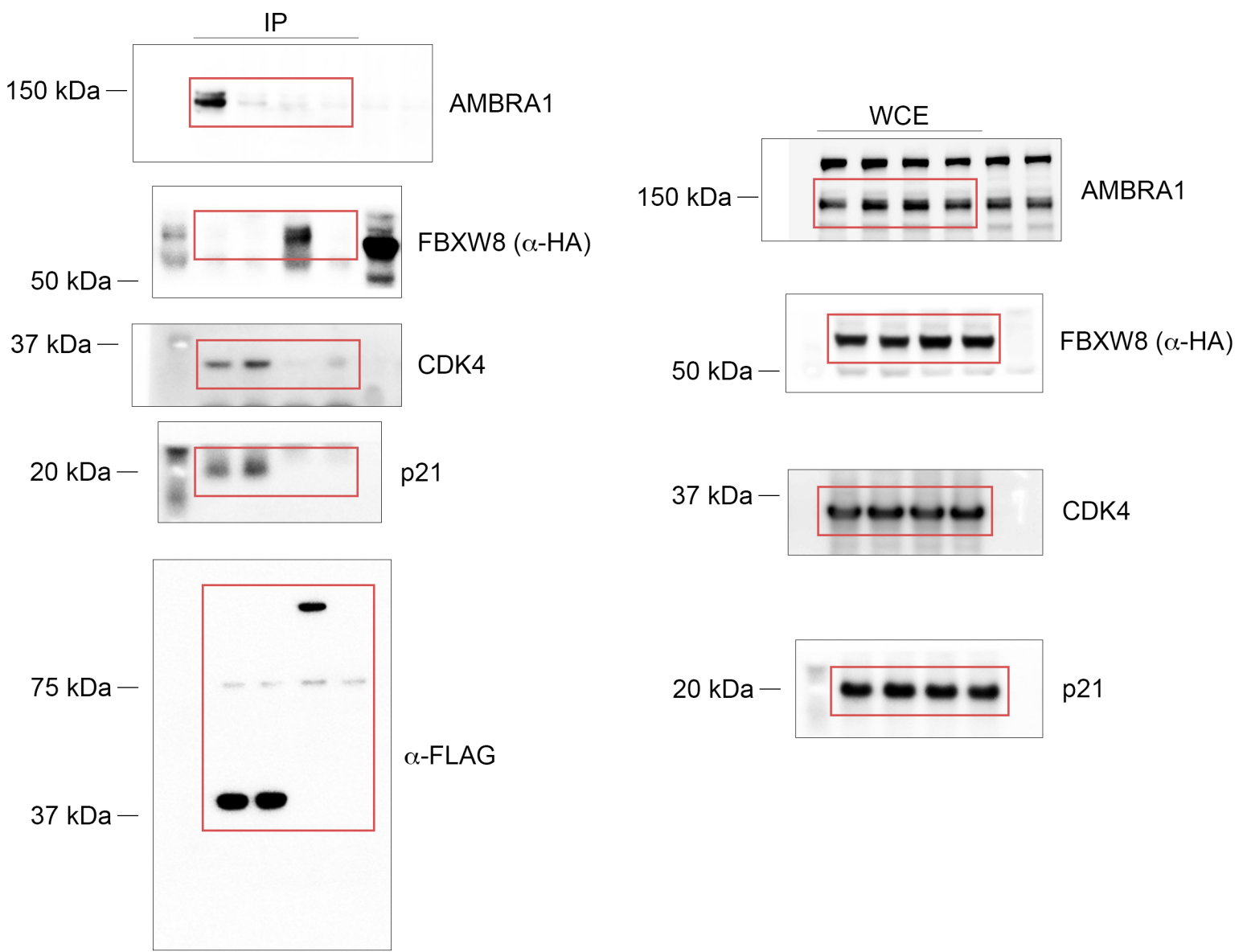

Extended Data Figure 4m

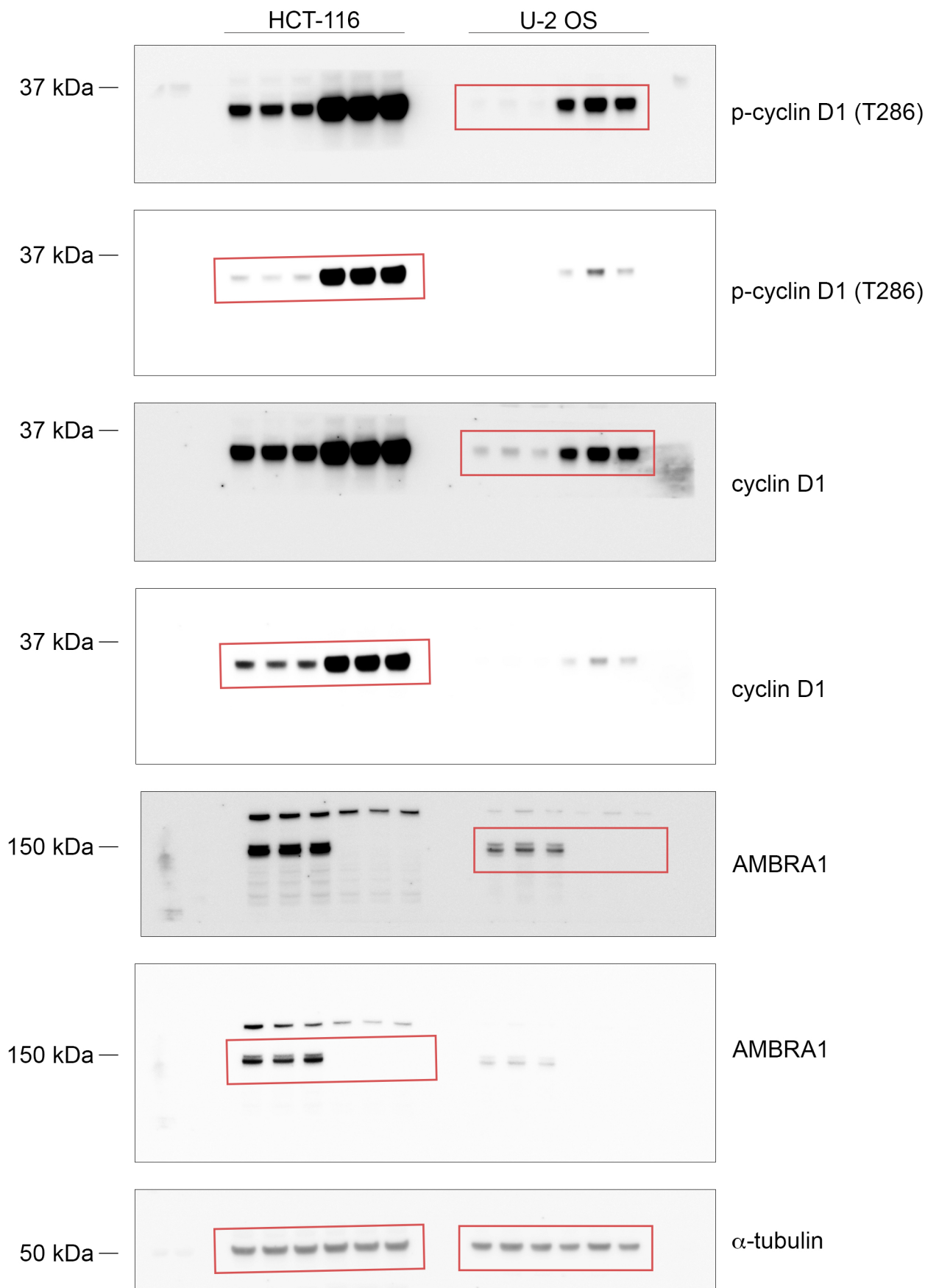

Extended Data Figure 4n

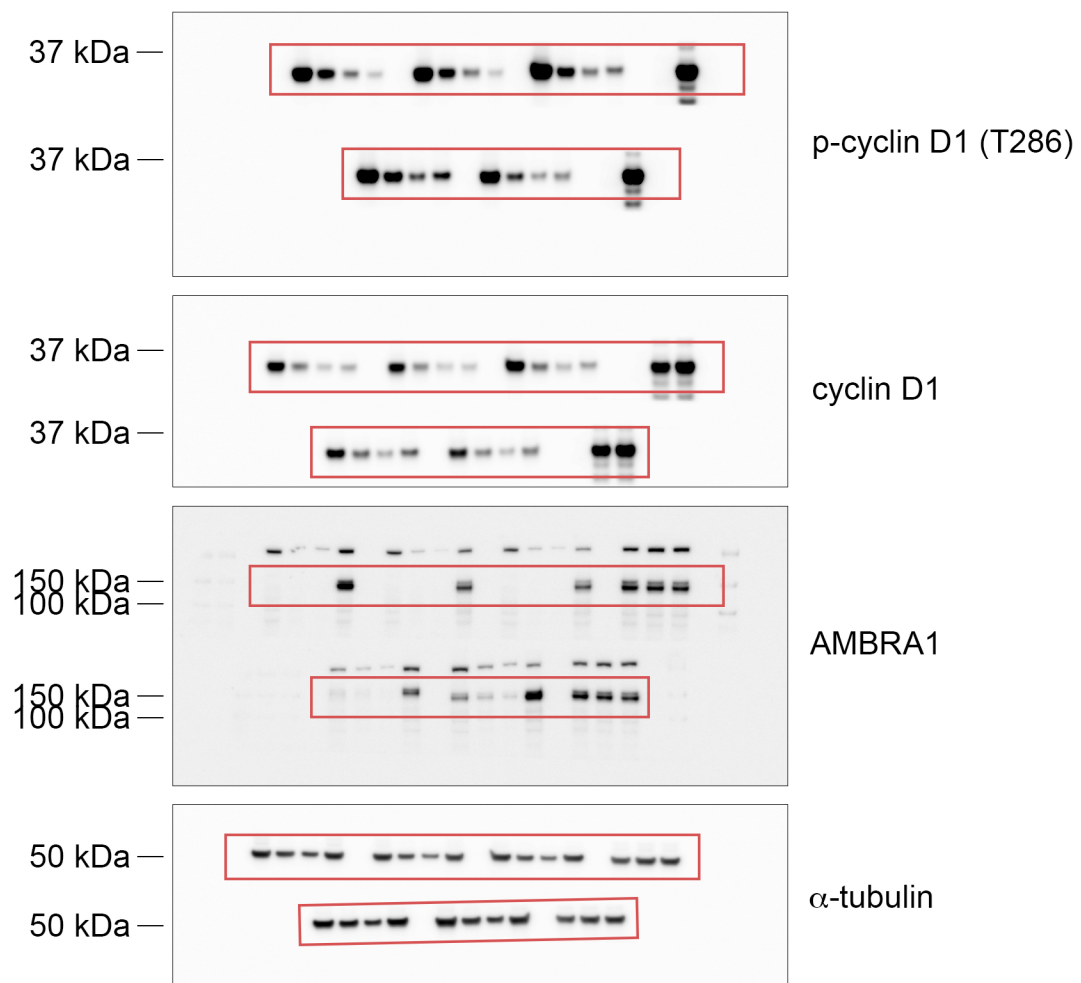

Extended Data Figure 4n - *continued*

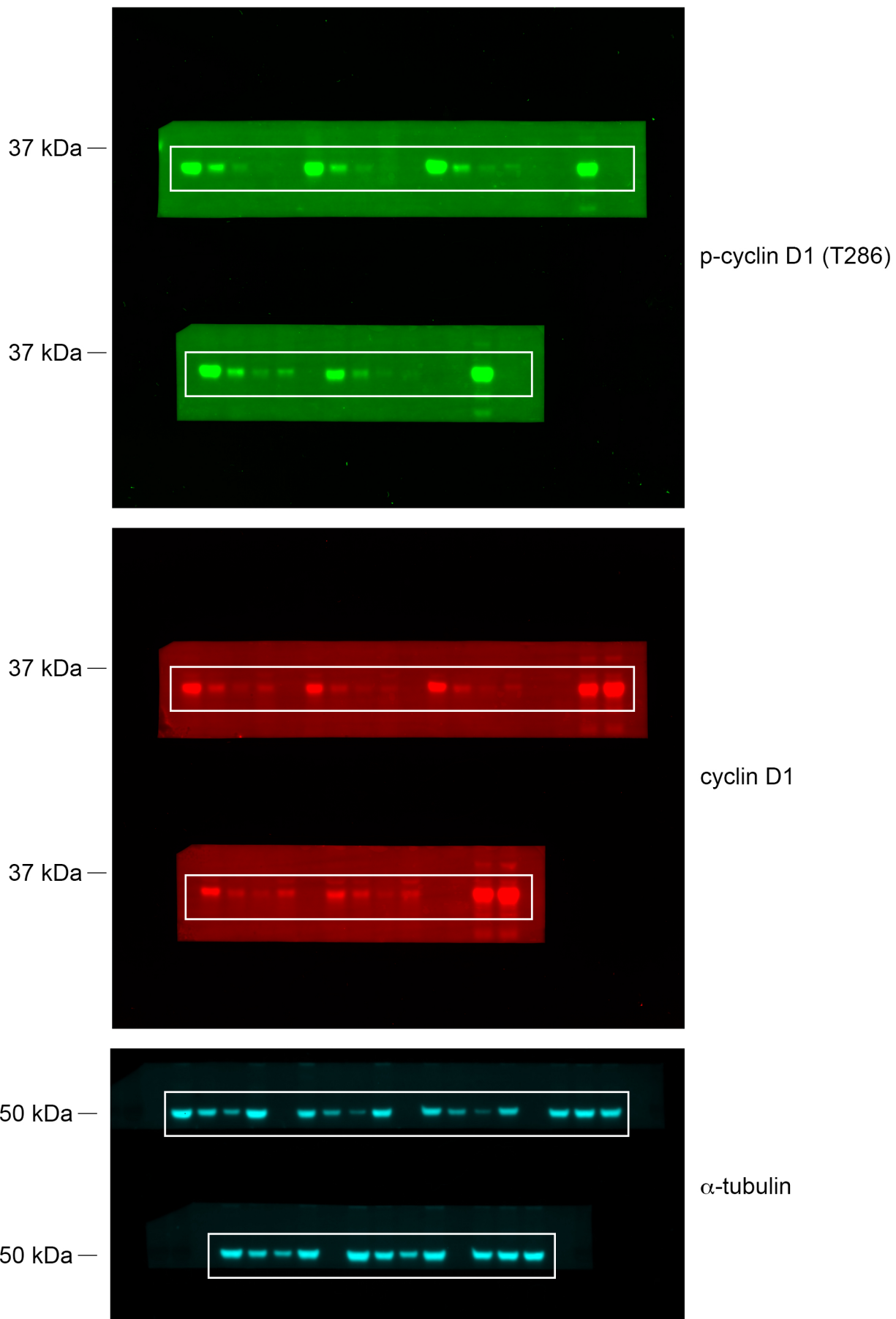

Extended Data Figure 4p

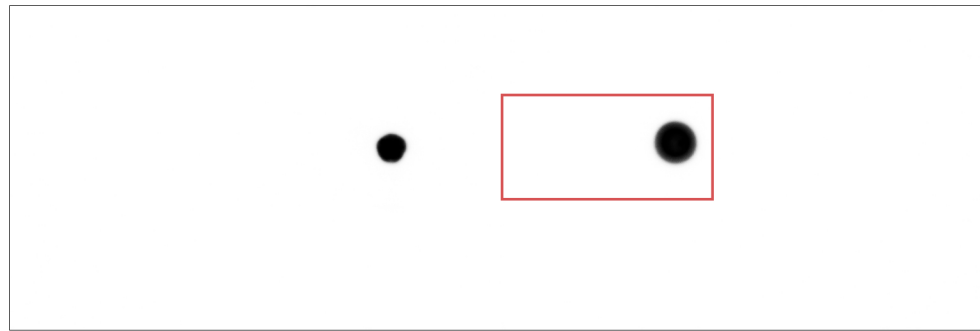

p-cyclin D1 (T286)

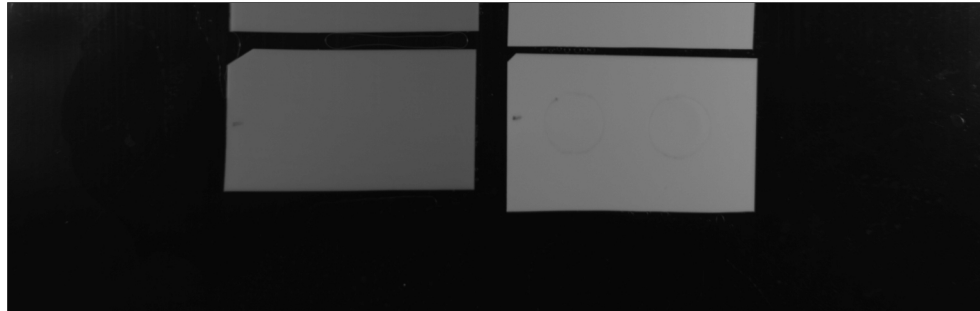

p-cyclin D1 (T286)
Membrane Digital Image

Extended Data Figure 4q

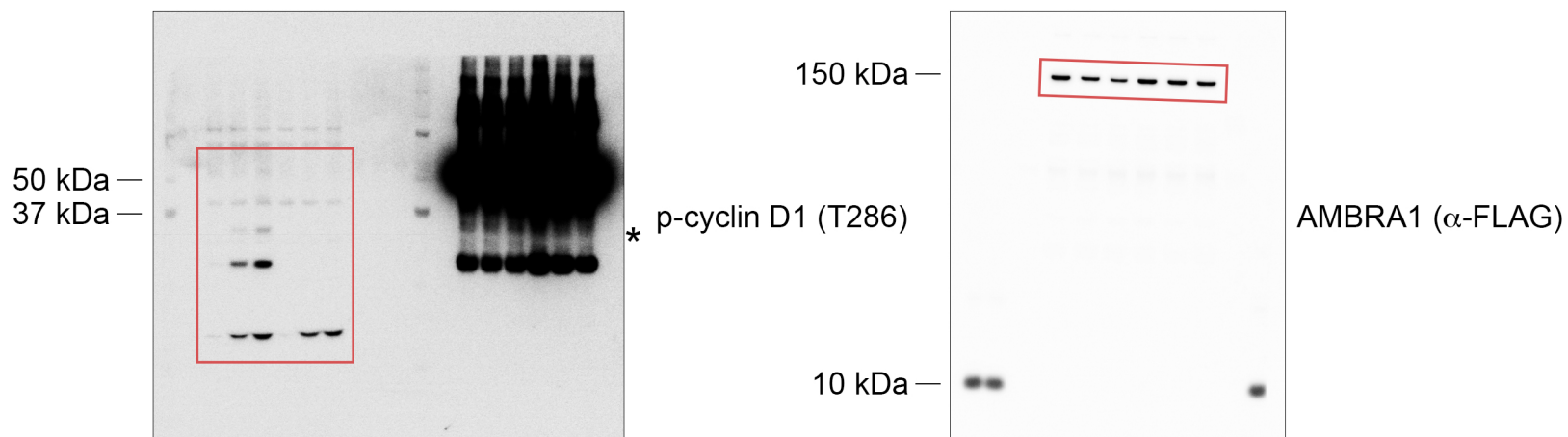

* Indicates a row of dead pixels from the CCD camera of the chemiluminescent imager

Extended Data Figure 5b

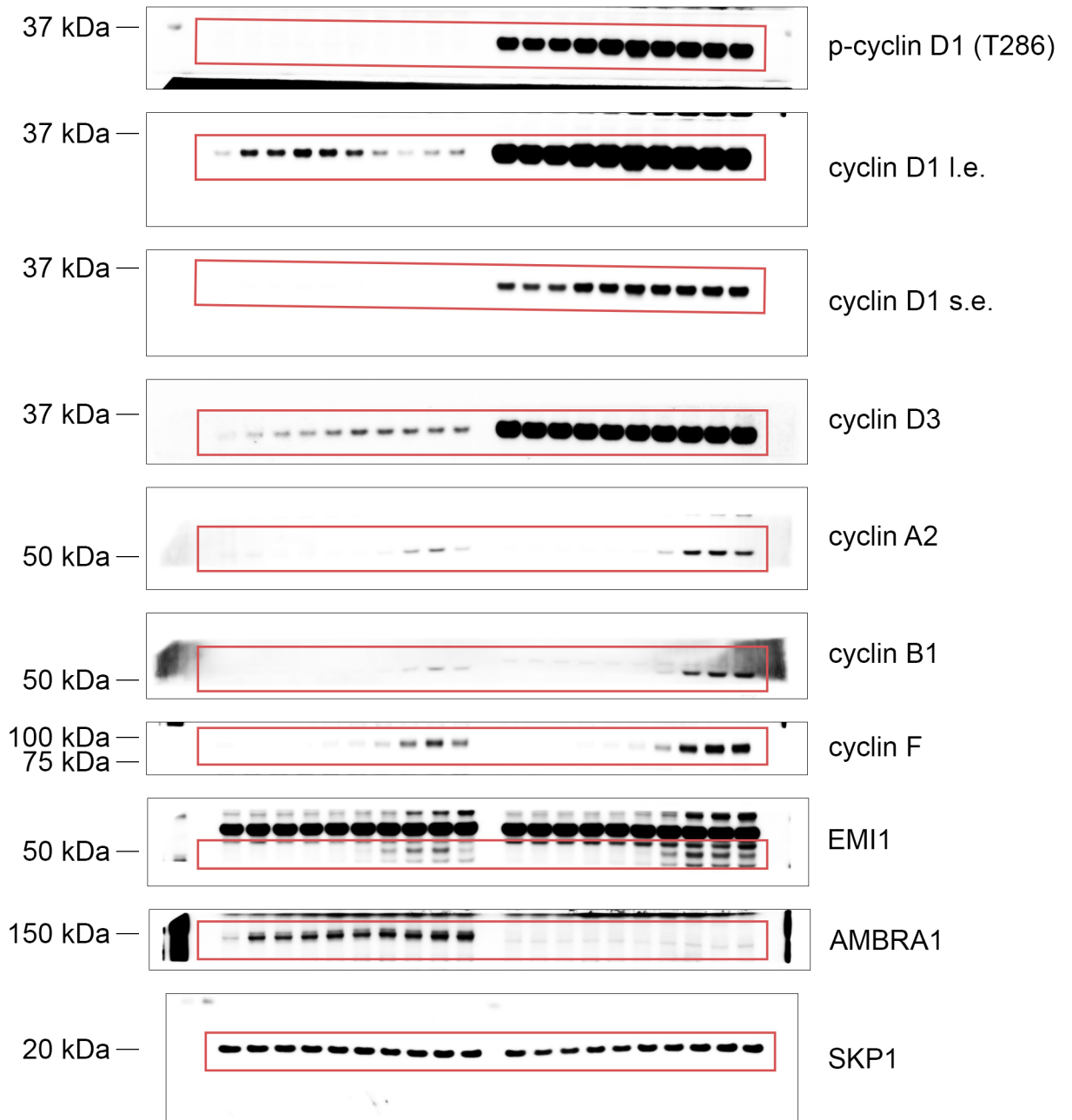

Extended Data Figure 5e

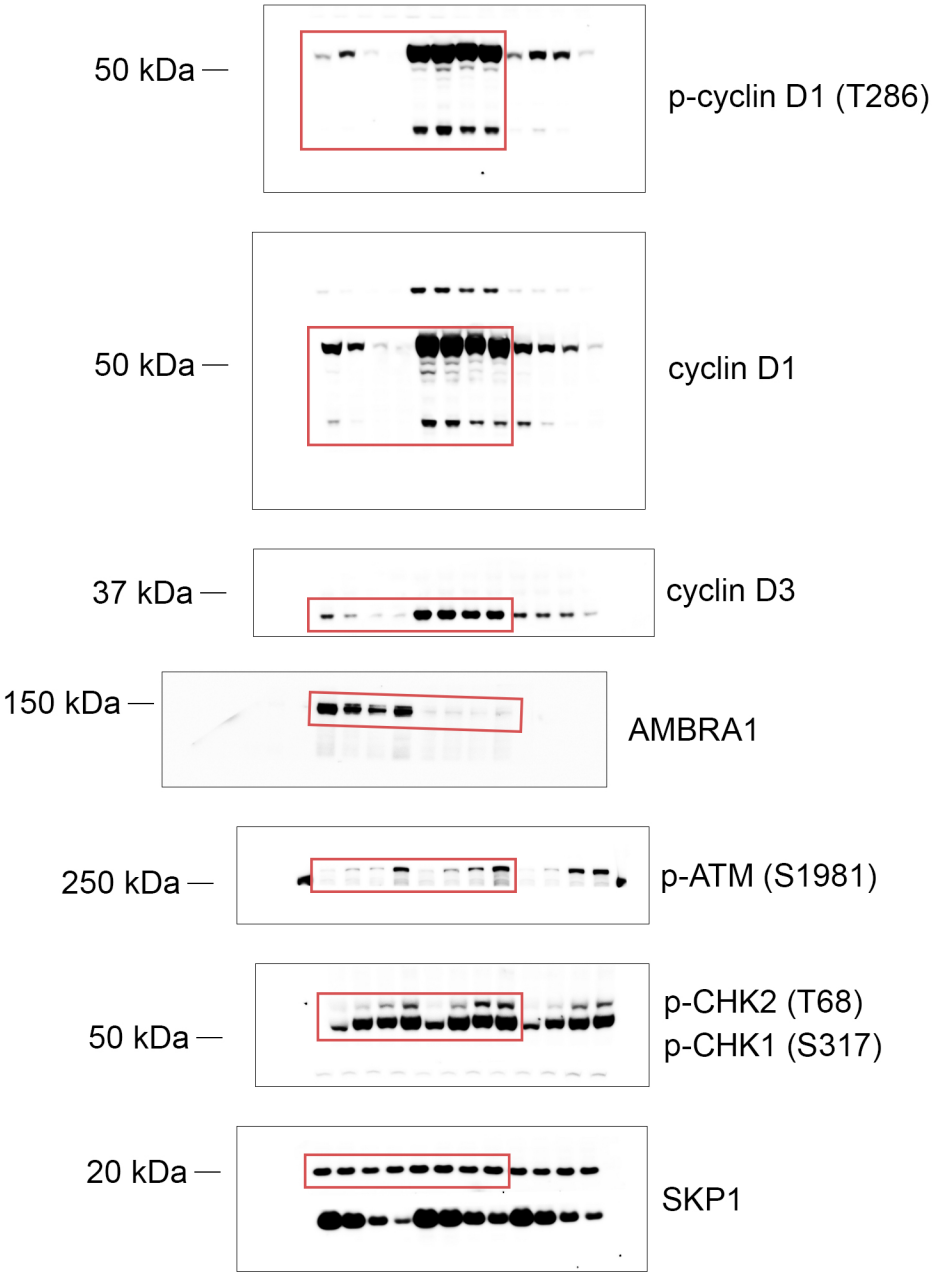

Extended Data Figure 5f

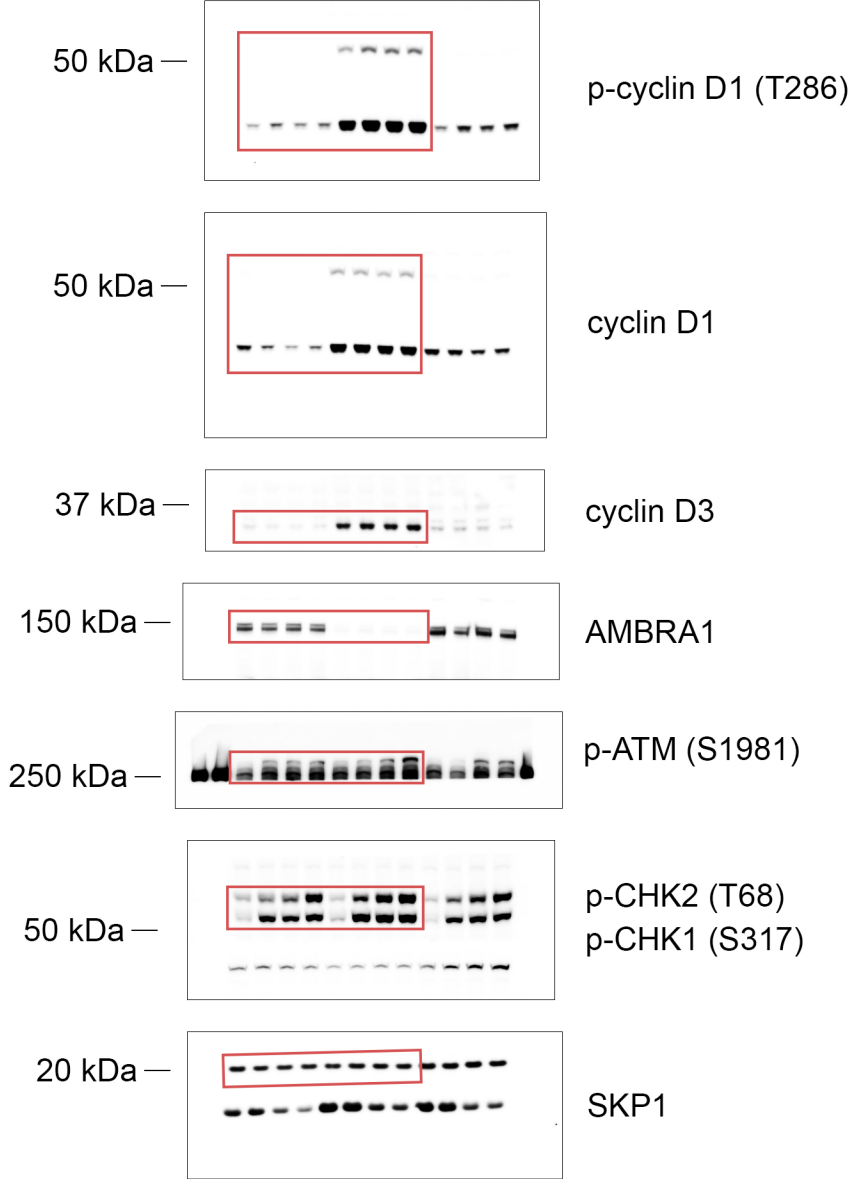

Extended Data Figure 5g

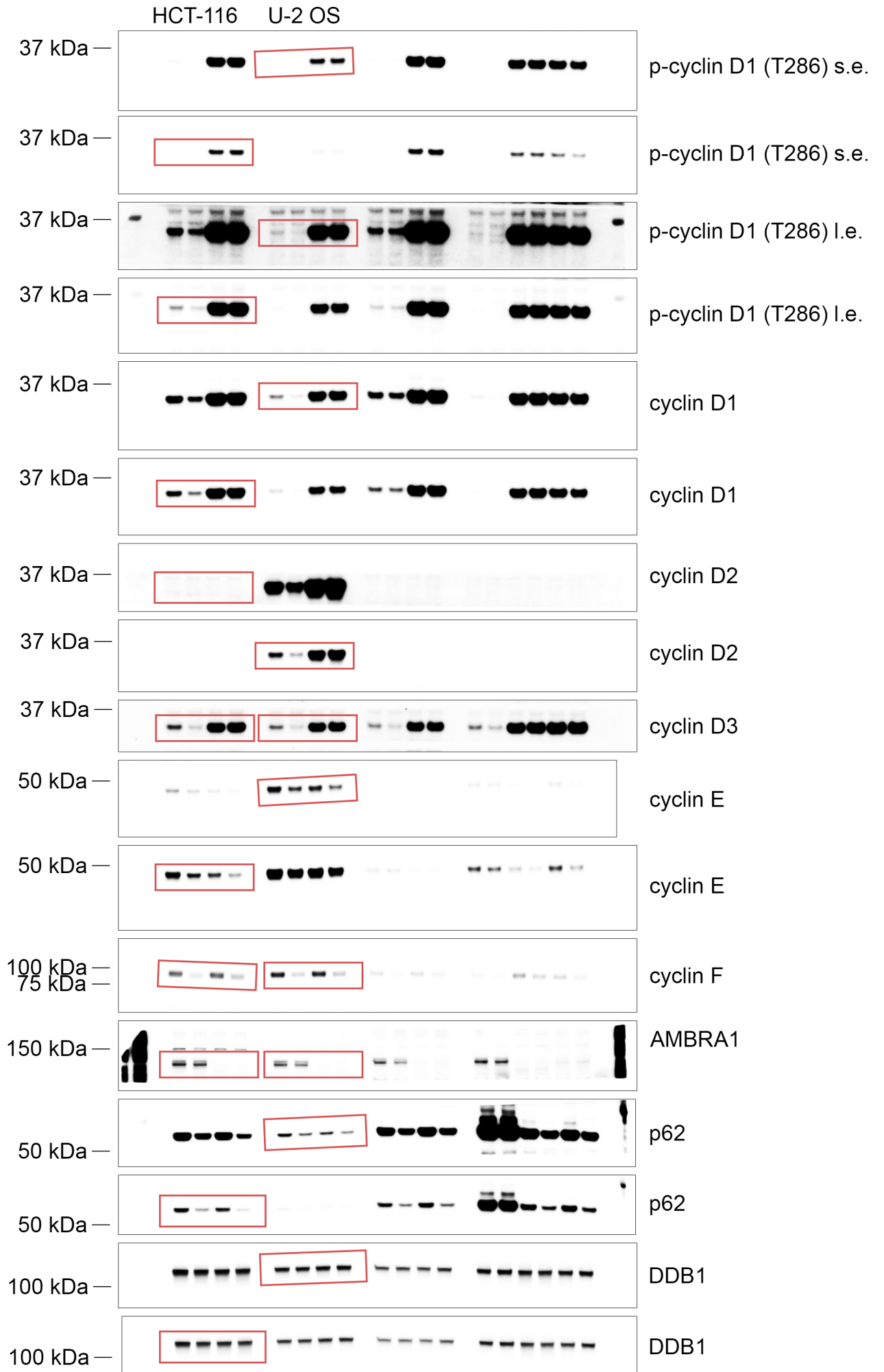

Extended Data Figure 5h

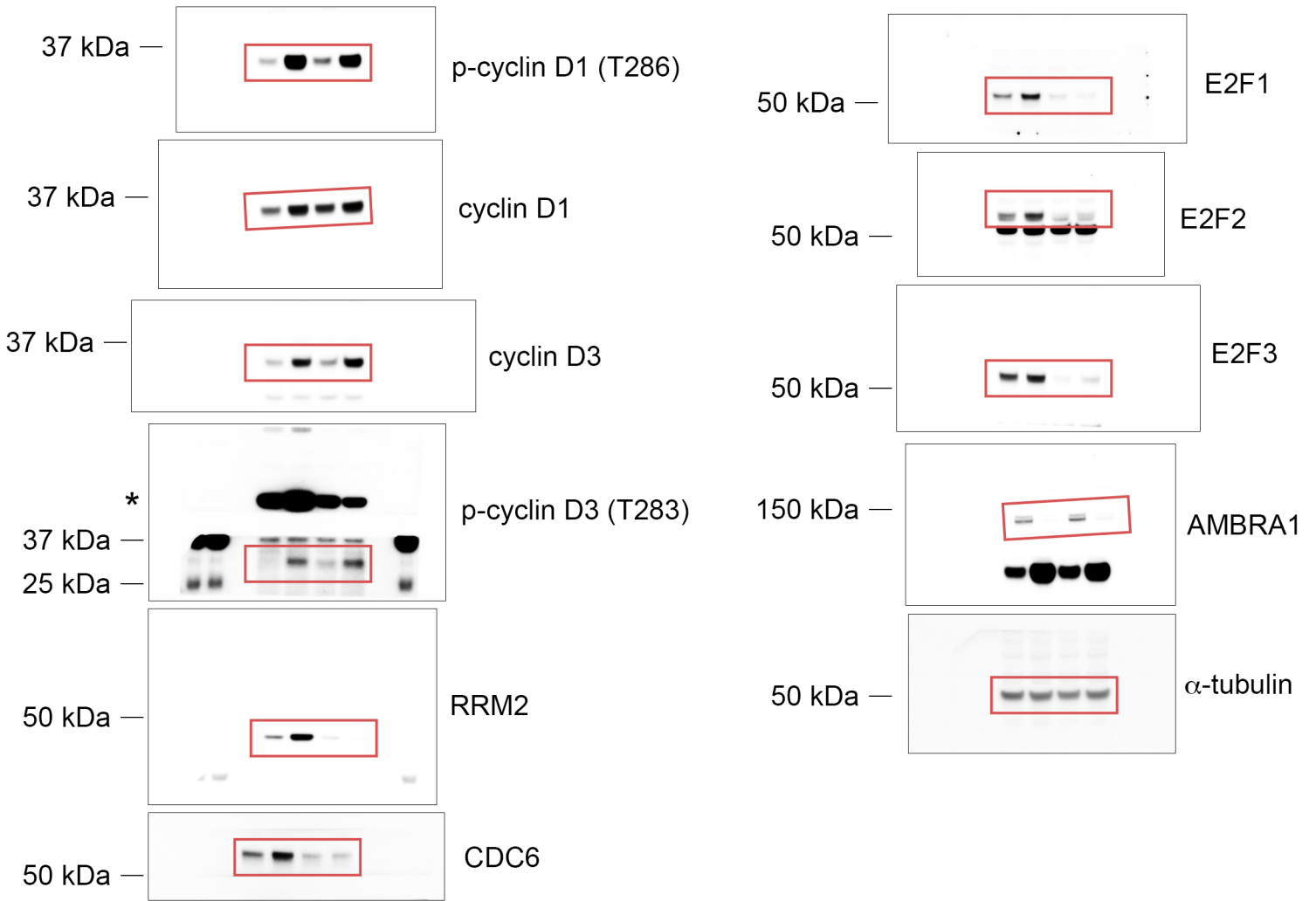

* Indicates a row of dead pixels from the CCD camera of the chemiluminescent imager

Extended Data Figure 5k

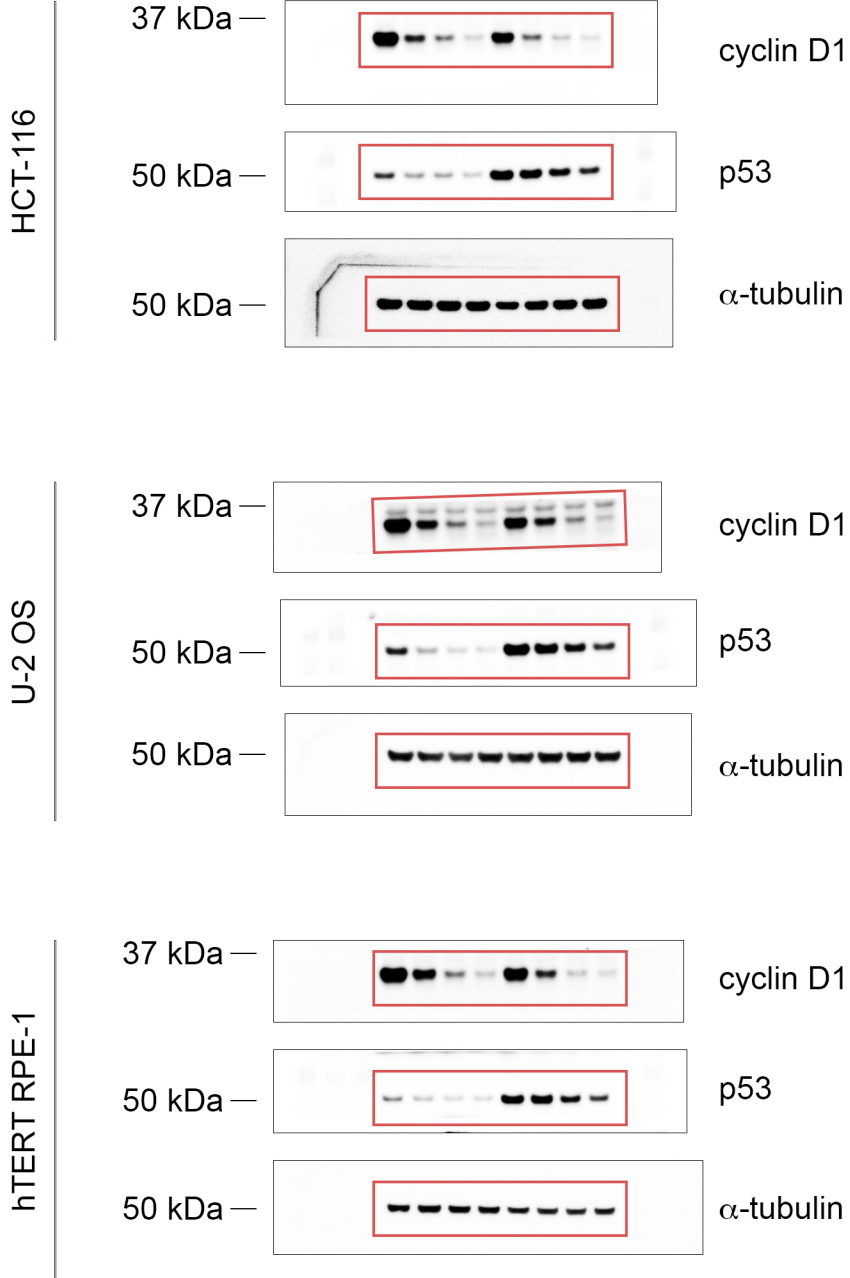

Extended Data Figure 6k

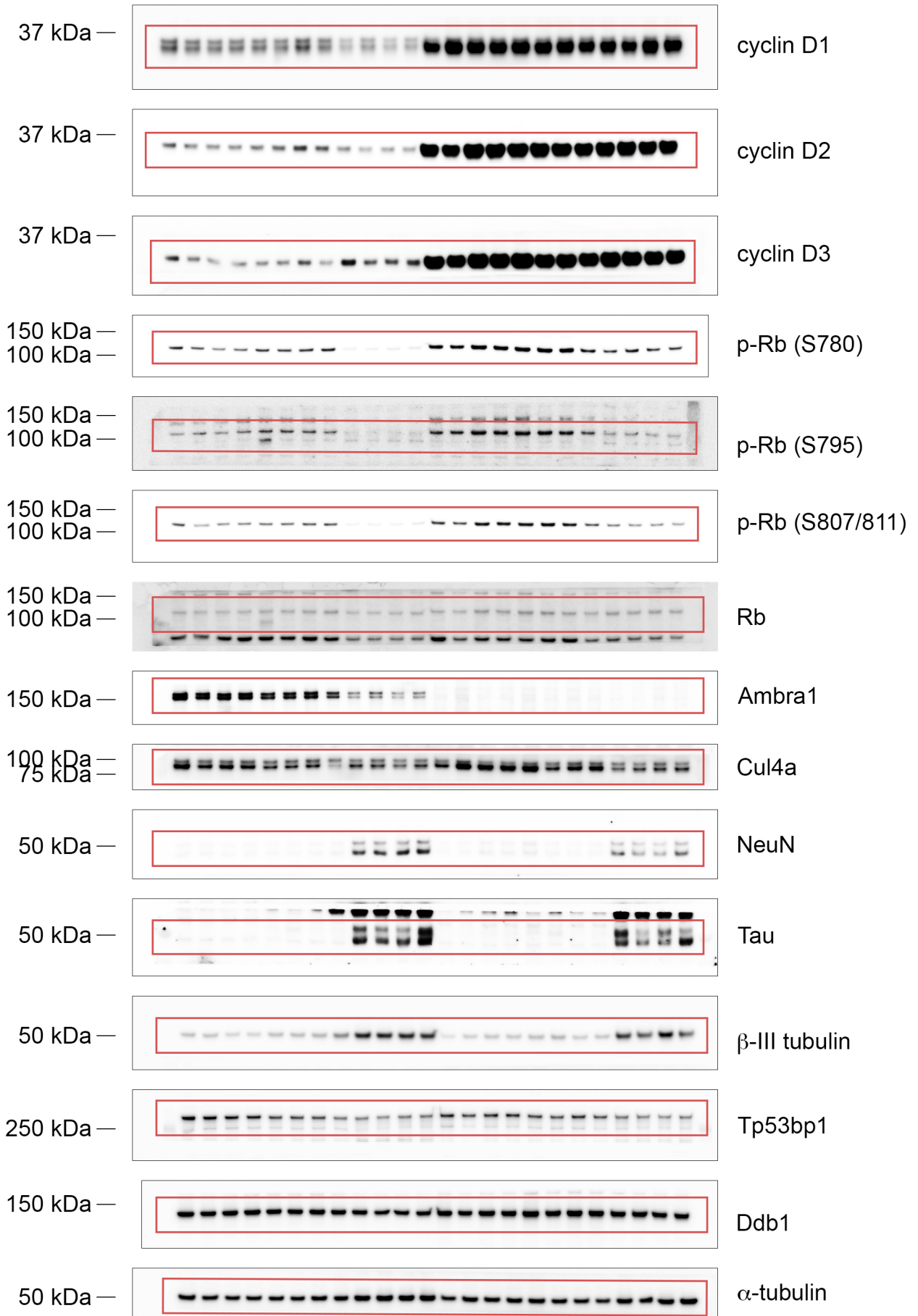

Extended Data Figure 10h

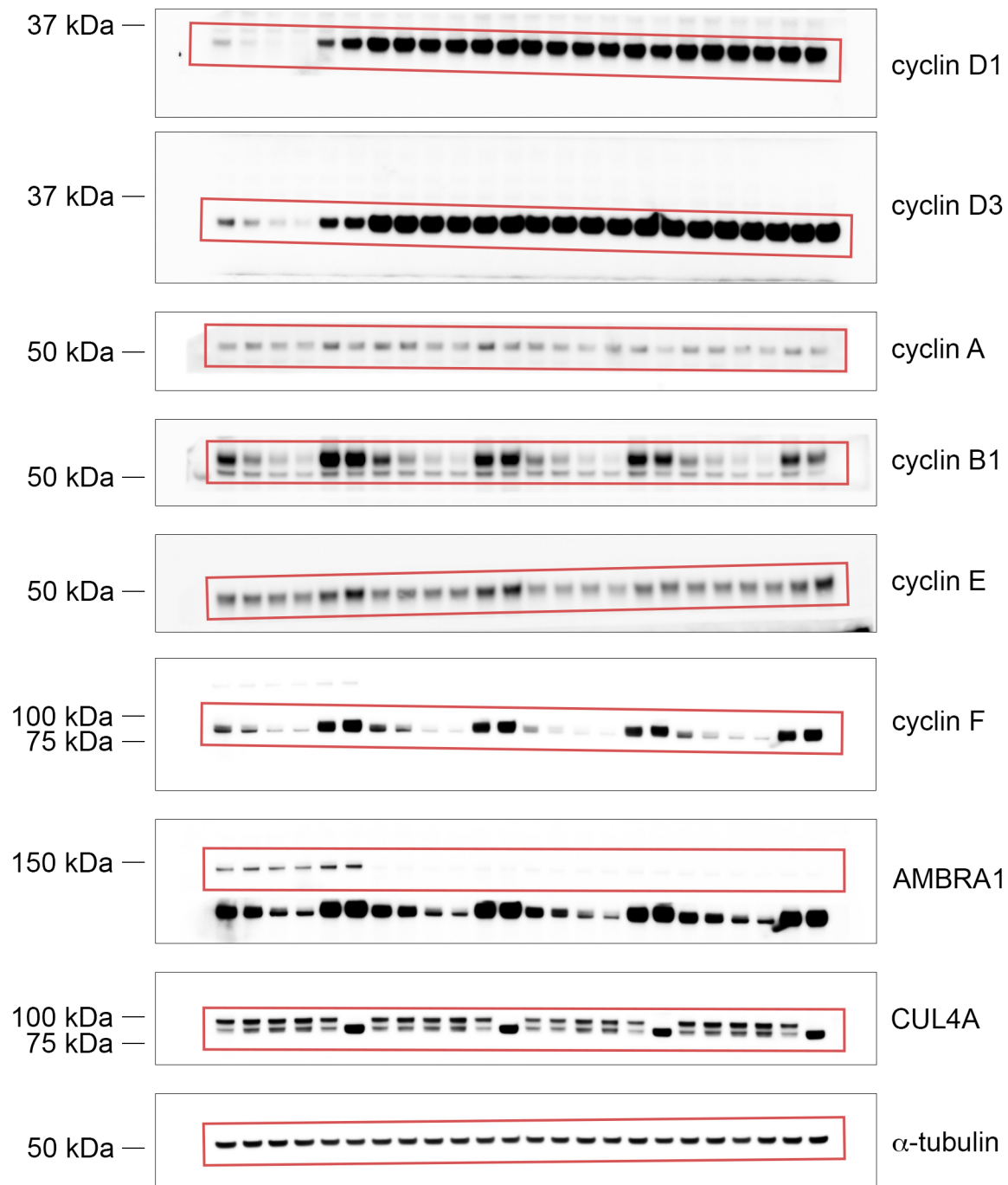

Extended Data Figure 10k

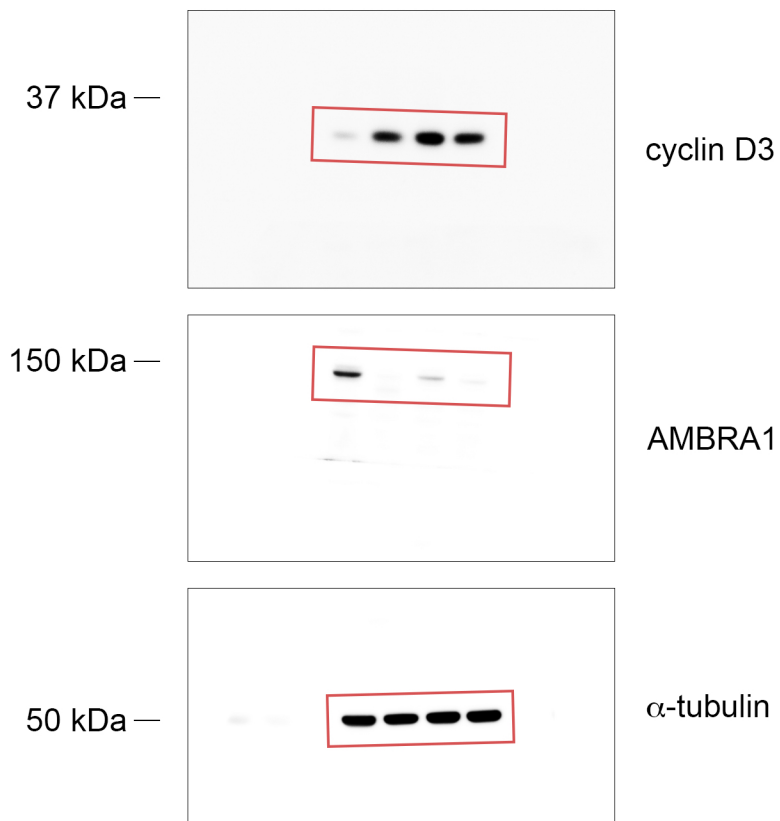

Extended Data Figure 11d

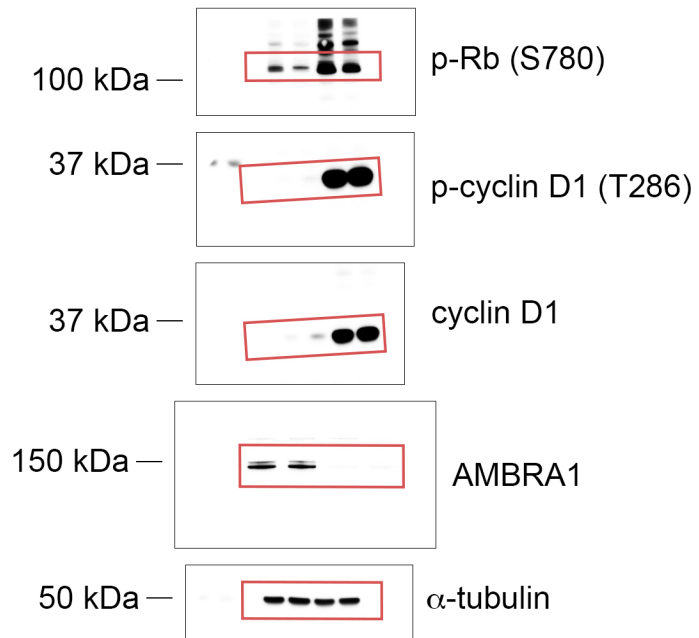

Extended Data Figure 11e

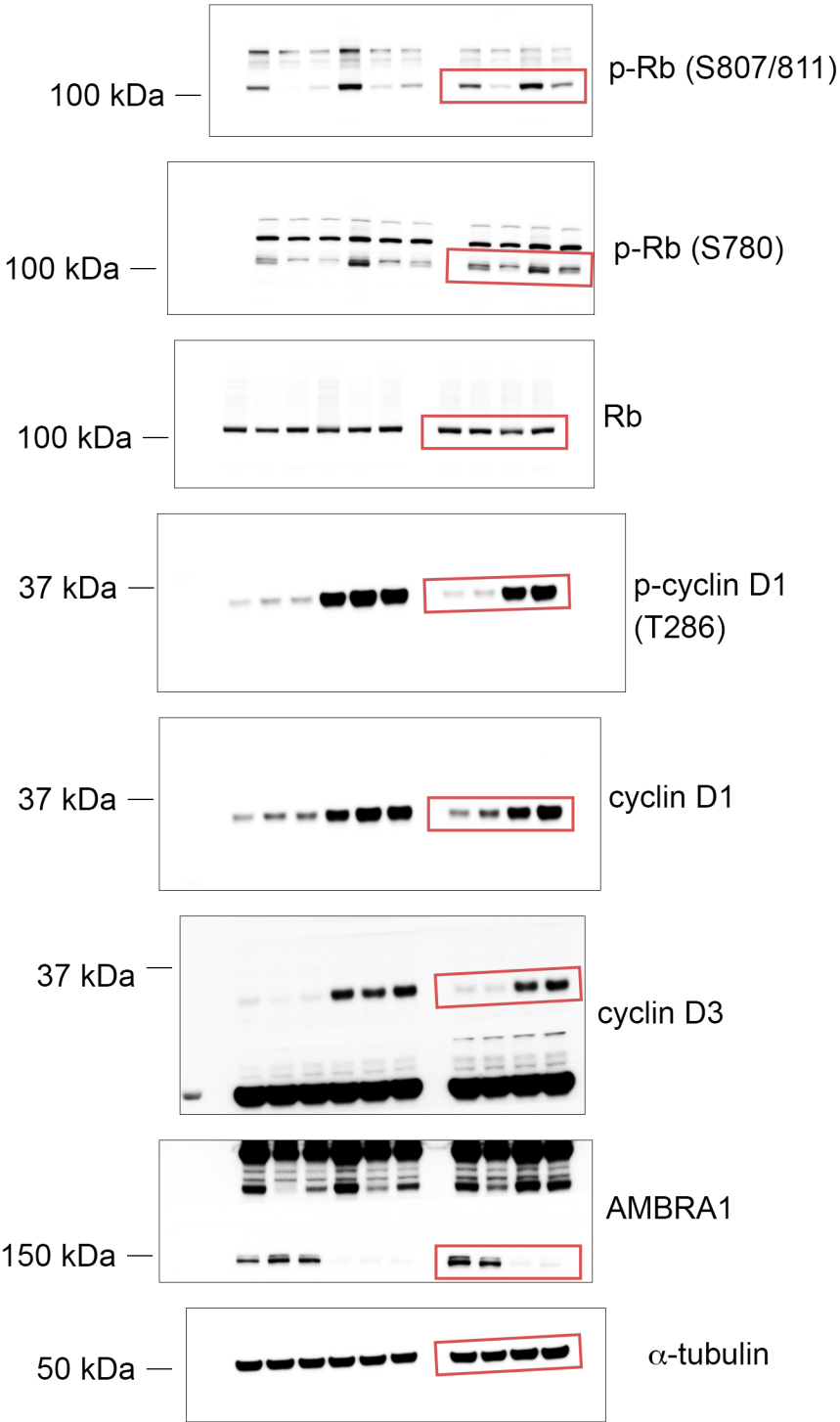

Extended Data Figure 11f

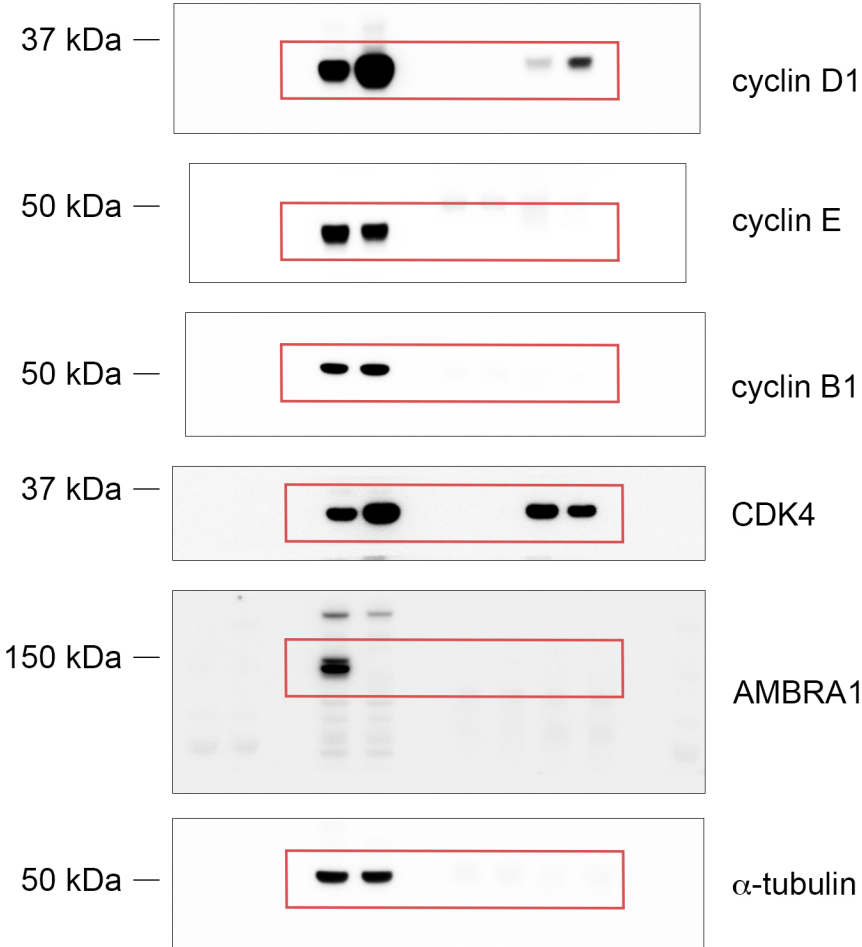

Extended Data Figure 11g

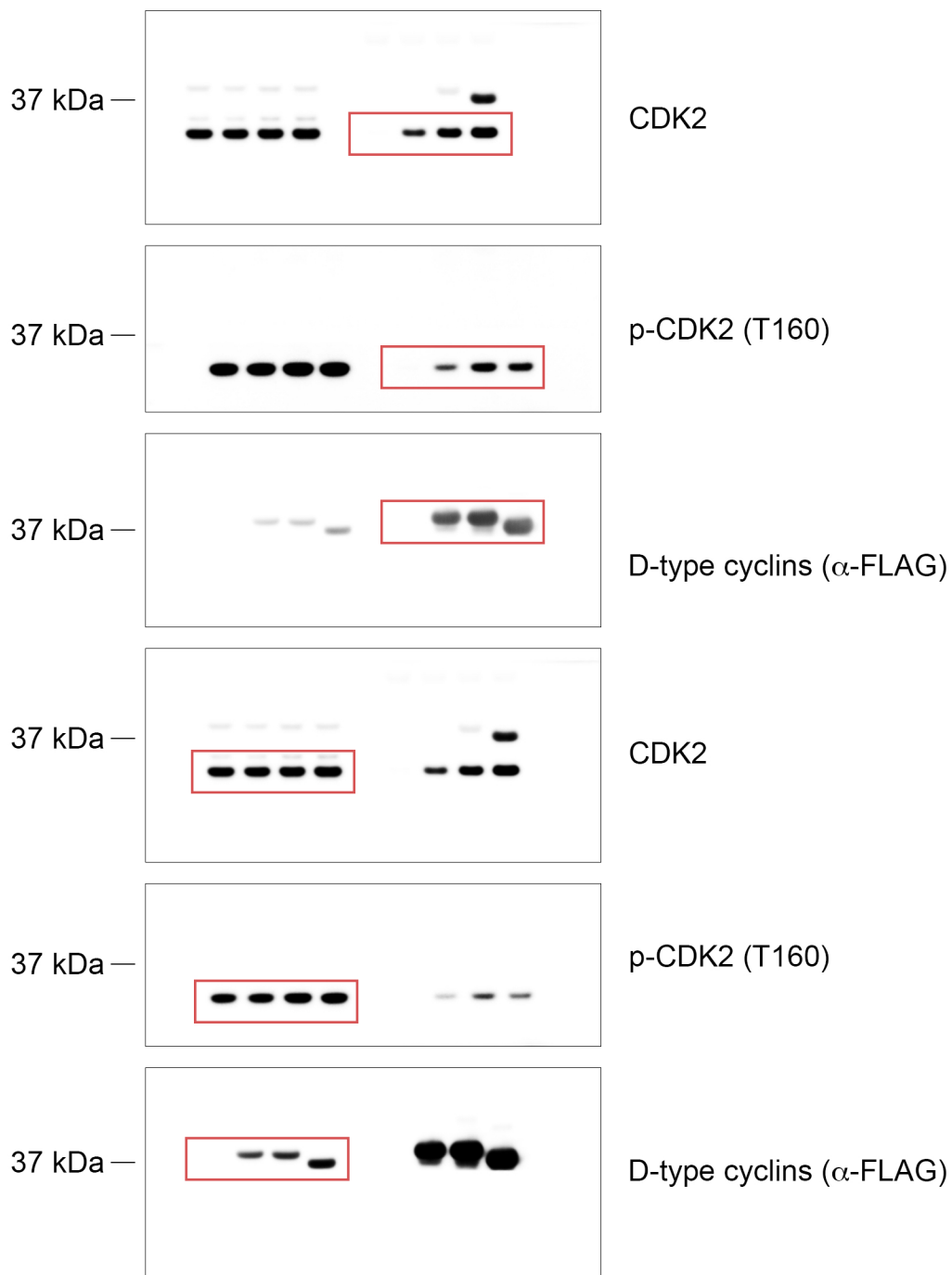

Extended Data Figure 11h

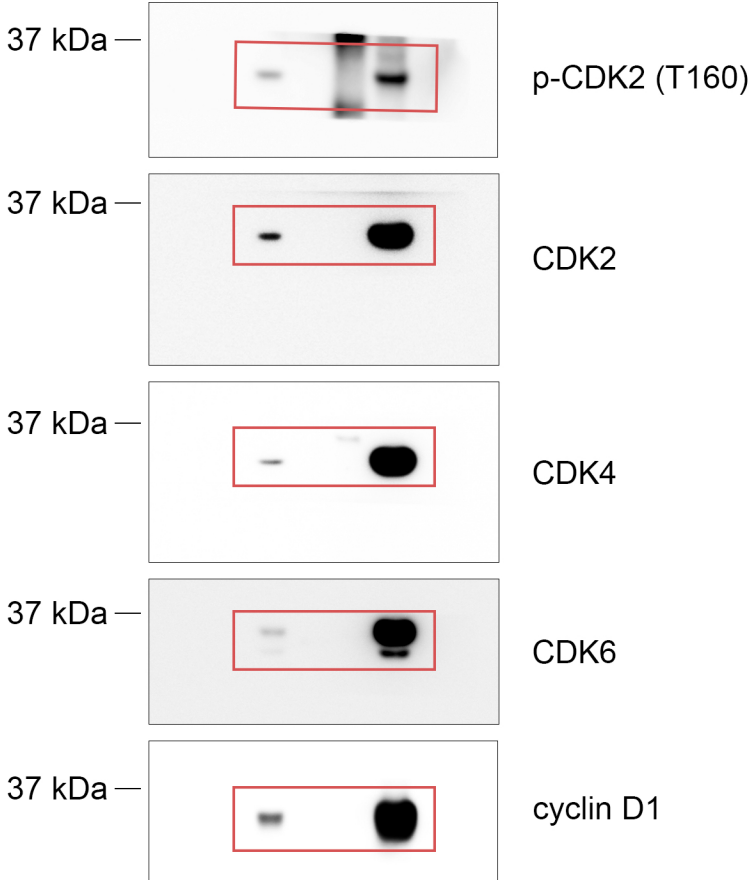

Extended Data Figure 11i

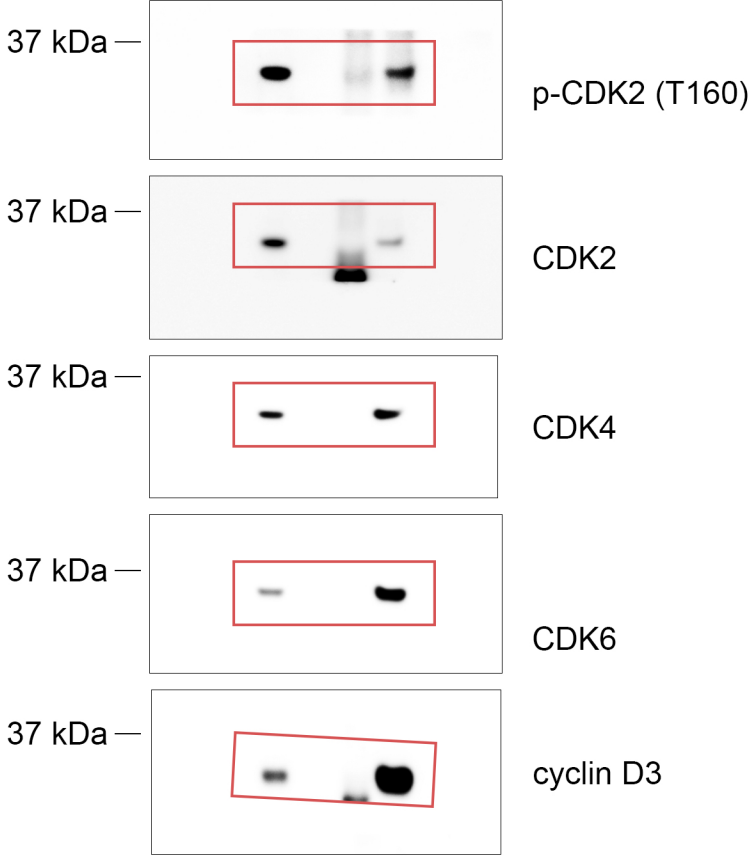

Extended Data Figure 11j - see above

Extended Data Figure 12a - see above

Extended Data Figure 12b

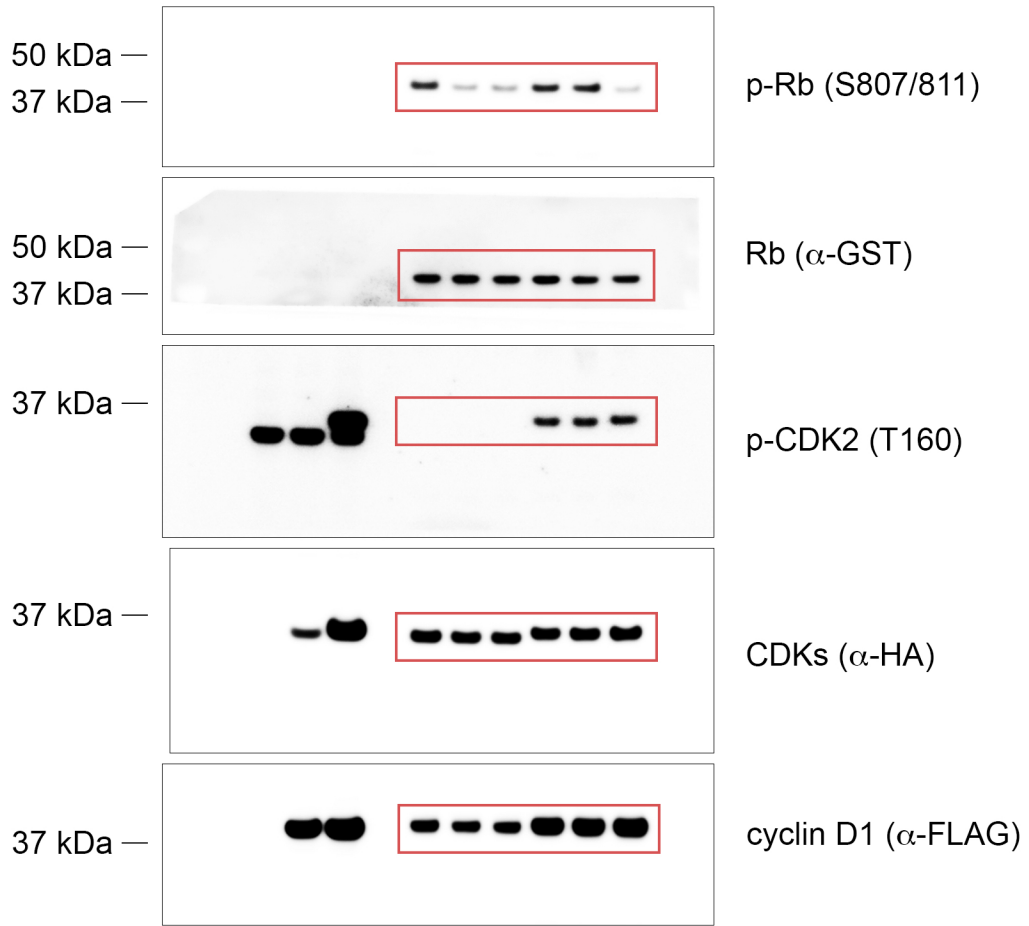

Extended Data Figure 12c

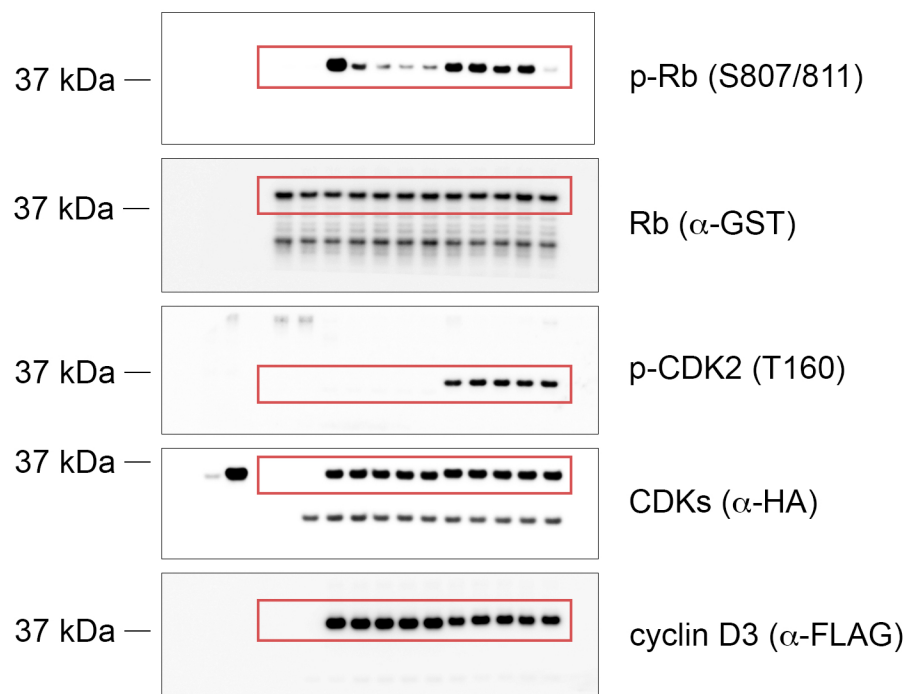

Extended Data Figure 12e

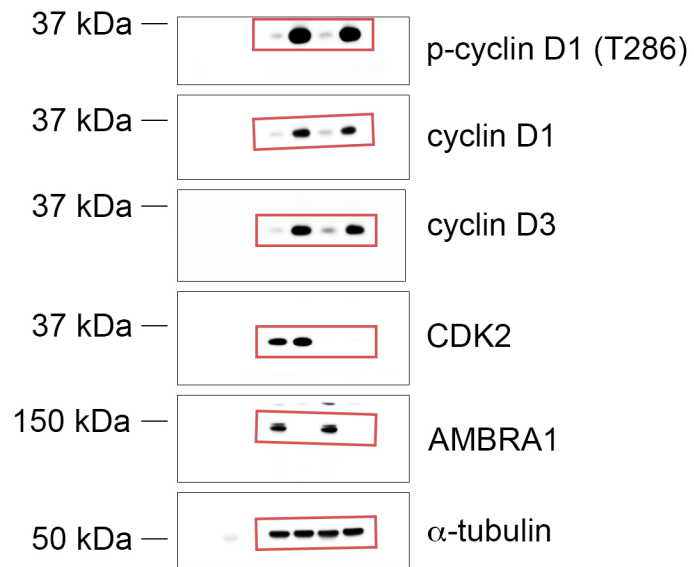

Supplementary Figure 1 This file contains the full scanned images obtained by electrophoretic separation